



Product schematic

N-200A

3-jaw through-hole power chuck (adapter included)

- Model N-200A chucks are assembled with adaptor for ASA B5.9 type A spindles.

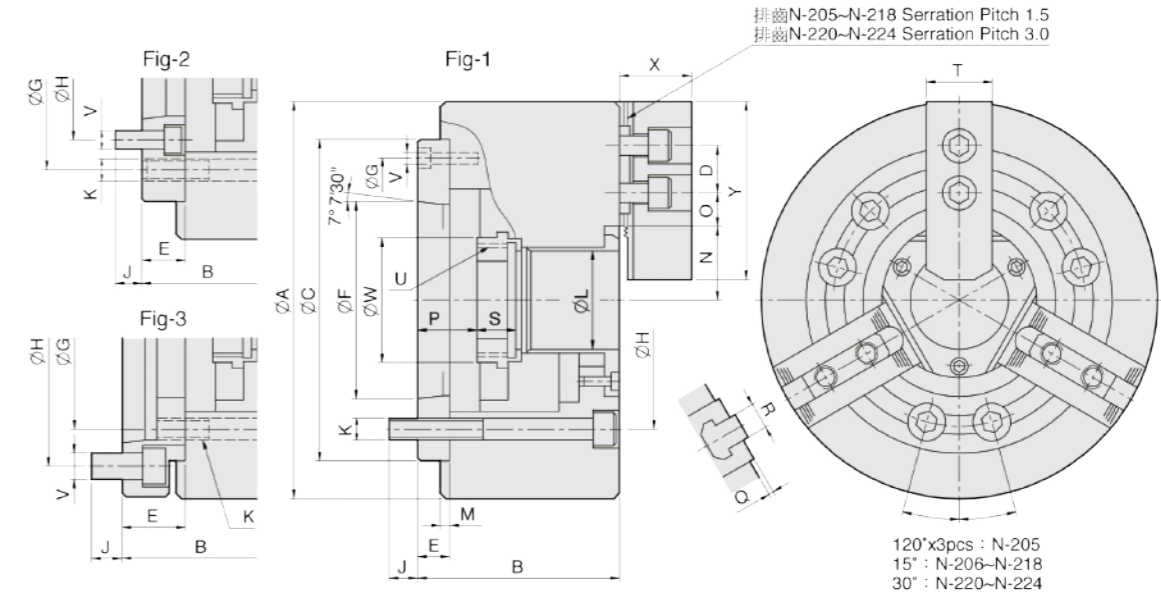

UNIT : mm

SPEC Model	Through-Hole (mm)	Plunger Stroke (mm)	Jaw Stroke (In Dia.) (mm)	Max. Pull Force (kgf)	Max. Gripping Force (kgf)	Max. Operating Pressure (kgf/cm ²)	Max. Speed (r.p.m.)	Weight (kg)	Moment Of Inertia I (kg·m ²)	Matching Cylinder	Matching Hard Jaw	Matching Soft Jaw	Gripping O.D. Range (mm)
N-205A4	Ø33	10	5.4	1784	3671	28.5	7000	7.8	0.020	M1036	HJ05	HC05	Ø6-Ø135
N-205A5	Ø33	10	5.4	1784	3671	28.5	7000	9	0.023	M1036	HJ05	HC05	Ø6-Ø135
N-206A4	Ø45	12	5.5	2243	5812	28.5	6000	15.5	0.065	M1246	HJ06	HC06	Ø15-Ø169
N-206A5	Ø45	12	5.5	2243	5812	28.5	6000	14.7	0.062	M1246	HJ06	HC06	Ø15-Ø169
N-206A6	Ø45	12	5.5	2243	5812	28.5	6000	17.3	0.073	M1246	HJ06	HC06	Ø15-Ø169
N-208A5	Ø52	16	7.4	3558	9075	26.5	5000	25.8	0.190	M1552	HJ08	HC08	Ø20-Ø210
N-208A6	Ø52	16	7.4	3558	9075	26.5	5000	25	0.184	M1552	HJ08	HC08	Ø20-Ø210
N-208A8	Ø52	16	7.4	3558	9075	26.5	5000	29.3	0.217	M1552	HJ08	HC08	Ø20-Ø210
N-210A6	Ø75	19	8.8	4385	11319	27.5	4200	41	0.370	M1875	HJ10	HC10	Ø25-Ø254
N-210A8	Ø75	19	8.8	4385	11319	27.5	4200	38	0.340	M1875	HJ10	HC10	Ø25-Ø254
N-210A11	Ø75	19	8.8	4385	11319	27.5	4200	48.4	0.436	M1875	HJ10	HC10	Ø25-Ø254
N-212A6	Ø91	23	10.6	5812	14990	27.5	3300	62.5	0.809	M2091	HJ12	HC12	Ø30-Ø304
N-212A8	Ø91	23	10.6	5812	14990	27.5	3300	59.5	0.770	M2091	HJ12	HC12	Ø30-Ø304
N-212A11	Ø91	23	10.6	5812	14990	27.5	3300	69.9	0.912	M2091	HJ12	HC12	Ø30-Ø304
N-215A8	Ø117.5	23	10.6	7240	18355	23.5	2500	125	2.255	M2511S	HJ15	HC15	Ø50-Ø381
N-215A11	Ø117.5	23	10.6	7240	18355	23.5	2500	118	2.241	M2511S	HJ15	HC15	Ø50-Ø381
N-215A15	Ø117.5	23	10.6	7240	18355	23.5	2500	138	2.822	M2511S	HJ15	HC15	Ø50-Ø381
N-218A8	Ø117.5	23	10.6	7240	18355	23.5	2000	146	3.961	M2511S	HJ15	HC15	Ø50-Ø450
N-218A11	Ø117.5	23	10.6	7240	18355	23.5	2000	138	3.744	M2511S	HJ15	HC15	Ø50-Ø450
N-218A15	Ø117.5	23	10.6	7240	18355	23.5	2000	191	5.183	M2511S	HJ15	HC15	Ø50-Ø450
N-220A11	Ø180	23	10.6	9177	23861	30.6	1800	215	7.355	ML2816	HJ24-1	HC24-1	Ø120-Ø510
N-220A15	Ø180	23	10.6	9177	23861	30.6	1800	202	6.910	ML2816	HJ24-1	HC24-1	Ø120-Ø510
N-224A11	Ø205	26	12	9177	23861	26.5	1400	332	18.199	ML3320	HJ24-1	HC24-1	Ø150-Ø610
N-224A15	Ø205	26	12	9177	23861	26.5	1400	317	17.376	ML3320	HJ24-1	HC24-1	Ø150-Ø610
N-224A20	Ø205	26	12	9177	23861	26.5	1400	286	15.677	ML3320	HJ24-1	HC24-1	Ø150-Ø610
N-232A11	Ø230	34	18	10197	24472	29.5	1200	530	43	ML3320	HJ24-1	HC24-1	Ø210-Ø800
N-232A15	Ø230	34	18	10197	24472	29.5	1200	515	43	ML3320	HJ24-1	HC24-1	Ø210-Ø800
N-232A20	Ø230	34	18	10197	24472	29.5	1200	485	42	ML3320	HJ24-1	HC24-1	Ø210-Ø800

UNIT : mm

DIM Model	A	B	C (H6)	D	E	F	G	H	J	K	L	M	N max.	O max.	O min.	P max.	P min.	Q	R	S	T	U max.	V	W	X	Y	Reference
N-205A4	135	71	110	14	15	63.513	96	82.55	15.5	3-M10	33	4	26.5	19.75	7.75	16	6	2	10	20	25	M40x1.5	3-M6	44.5	31	62	Fig-1
N-205A5	135	88	110	14	32	82.563	82.55	104.78	14	3-M10	33	4	26.5	19.75	7.75	33	23	2	10	20	25	M40x1.5	6-M10	44.5	31	62	Fig-3
N-206A4	169	96	140	20	20	63.513	104.78	82.55	16	6-M10	45	5	32	22.75	9.25	31	19	2	12	19	31	M55x2	6-M10	60	37	73	Fig-2
N-206A5	169	91	140	20	15	82.563	116	104.78	16	6-M10	45	5	32	22.75	9.25	26	14	2	12	19	31	M55x2	3-M6	60	37	73	Fig-1
N-206A6	169	111	140	20	35	106.375	104.78	133.35	16	6-M10	45	5	32	22.75	9.25	46	34	2	12	19	31	M55x2	6-M12	60	37	73	Fig-3
N-208A5	210	109	170	25	23	82.563	133.35	104.78	14	6-M12	52	5	38.7	29.75	11.75	37.5	21.5	2	14	20.5	35	M60x2	6-M10	66	38	95	Fig-2
N-208A6	210	103	170	25	17	106.375	150	133.35	18	6-M12	52	5	38.7	29.75	11.75	31.5	15.5	2	14	20.5	35	M60x2	3-M6	66	38	95	Fig-1
N-208A8	210	126	170	25	40	139.719	133.35	171.45	24	6-M12	52	5	38.7	29.75	11.75	54.5	38.5	2	14	20.5	35	M60x2	6-M16	66	38	95	Fig-3
N-210A6	254	120	220	30	25	106.375	171.45	133.35	18	6-M16	75	5	51.4	33.75	14.25	33.5	14.5	2	16	25	40	M85x2	6-M12	94	43	110	Fig-2
N-210A8	254	113	220	30	18	139.719	190	171.45	24	6-M16	75	5	51.4	33.75	14.25	26.5	7.5	2	16	25	40	M85x2	3-M8	94	43	110	Fig-1
N-210A11	254	145	220	30	50	196.869	171.45	235	28	6-M16	75	5	51.4	33.75	14.25	58.5	39.5	2	16	25	40	M85x2	6-M20	94	43	110	Fig-3
N-212A6	304	129	220	30	25	106.375	171.45	133.35	18	6-M16	91	6	61.3	45.75	15.75	33	10	2	21	28	50	M100x2	6-M12	108	51	130	Fig-2
N-212A8	304	122	220	30	18	139.719	190	171.45	25	6-M16	91	6	61.3	45.75	15.75	26	3	2	21	28	50	M100x2	3-M8	108	51	130	Fig-1
N-212A11	304	154	220	30	50	196.869	171.45	235	28	6-M16	91	6	61.3	45.75	15.75	58	35	2	21	28	50	M100x2	6-M20	108	51	130	Fig-3
N-215A8	381	160	300	43	33	139.719	235	171.45	24	6-M20	117.5	6	82	45.25	15.25	40	17	5	22	43	62	M130x2	6-M16	139	66	165	Fig-2
N-215A11	381	149	300	43	22	196.869	260	235	28	6-M20	117.5	6	82	45.25	15.25	29	6	5	22	43	62	M130x2	3-M10	139	66	165	Fig-1
N-215A15	381	184	300	43	57	285.775	235	330.2	29	6-M20	117.5	6	82	45.25	15.25	64	41	5	22	43	62	M130x2	6-M24	139	66	165	Fig-3
N-218A8	450	160	300	43	33	139.719	235	171.45	24	6-M20	117.5	6	82	79.75	15.25	40	17	5	22	43	62	M130x2	6-M16	139	66	165	Fig-2
N-218A11	450	149	300	43	22	196.869	260	235	28	6-M20	117.5	6	82	79.75	15.25	29	6	5	22	43	62	M130x2	3-M10	139	66	165	Fig-1
N-218A15	450	184	300	43	57	285.775	235	330.2	29	6-M20	117.5	6	82	79.75	15.25	64	41	5	22	43	62	M130x2	6-M24	139	66	165	Fig-3
N-220A11	510	169	380	60	41	196.869	330.2	235	30	6-M24	180	6	112.5	60.5	24.5	52	29	5	25	38	64	M190x3	6-M20	206	73	180	Fig-2
N-220A15	510	155	380	60	27	285.775	330.2	330.2	33	6-M24	180	6	112.5	60.5	24.5	38	15	5	25	38	64	M190x3	3-M12	206	73	180	Fig-1
N-224A11	610	186	520	60	45	196.869	463.6	235	28	6-M24	205	6	131.9	87.5	24.5	61	35	5	25	38	64	M215x3	6-M20	230	73	180	Fig-2
N-224A15	610	183	520	60	42	285.775	463.6	330.2	32.5	6-M24	205	6	131.9	87.5	24.5	58	32	5	25	38	64	M215x3	6-M24	230	73	180	Fig-2
N-224A20	610	166	520	60	25	412.775	463.6	463.6	35	6-M24	205	6	131.9	87.5	24.5	41	15	5	25	38	64	M215x3	3-M10	230	73	180	Fig-1
N-232A11	800	189	520	60	45	196.869	463.6	235	28	6-M24	230	6	162	153.5	24.5	61	27	5	25	38	64	M250x3	6-M20	262	73	180	Fig-2
N-232A15	800	186	520	60	42	285.775	463.6	330.2	32.5	6-M24	230	6	162	153.5	24.5	58	24	5	25	38	64	M250x3	6-M24	262	73	180	Fig-2
N-232A20	800	169	520	60	25	412.775	463.6	463.6	35	6-M24	230	6	162	153.5	24.5	41	7	5	25	38	64	M250x3	3-M10	262	73	180	Fig-1



Product schematic

N-200

3-jaw through-hole power chuck (adapter excluded)

1. Large through-hole aperture.
2. High-speed rotation.

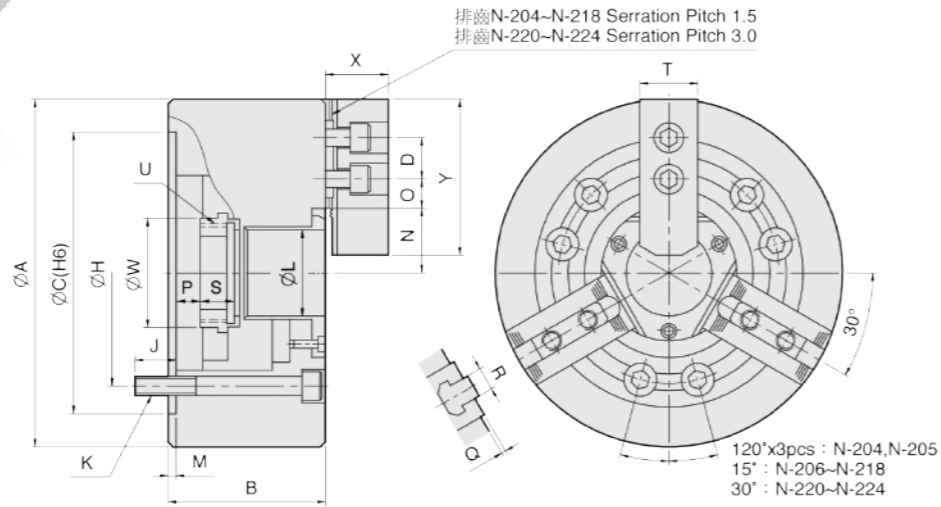

UNIT : mm

SPEC Model	Through-Hole (mm)	Plunger Stroke (mm)	Jaw Stroke (In Dia.) (mm)	Max. Pull Force (kgf)	Max. Gripping Force (kgf)	Max. Operating Pressure (kgf/cm ²)	Max. Speed (r.p.m.)	Weight (kg)	Moment Of Inertia I (kg·m ²)	Matching Cylinder	Matching Hard Jaw	Matching Soft Jaw	Gripping O.D. Range (mm)
N-204	Ø26	10	5.4	1428	2906	31.6	8000	4	0.007	M0928	HJ05	HC04	Ø4-Ø110
N-205	Ø33	10	5.4	1784	3671	28.5	7000	7	0.018	M1036	HJ05	HC05	Ø6-Ø135
N-206	Ø45	12	5.5	2243	5812	28.5	6000	13.5	0.057	M1246	HJ06	HC06	Ø15-Ø169
N-208	Ø52	16	7.4	3558	9075	26.5	5000	23	0.17	M1552	HJ08	HC08	Ø20-Ø210
N-210	Ø75	19	8.8	4385	11319	27.5	4200	35	0.315	M1875	HJ10	HC10	Ø25-Ø254
N-212	Ø91	23	10.6	5812	14990	27.5	3300	56.5	0.737	M2091	HJ12	HC12	Ø30-Ø304
N-215	Ø117.5	23	10.6	7240	18355	23.5	2500	111	2.27	M2511S	HJ15	HC15	Ø50-Ø381
N-218	Ø117.5	23	10.6	7240	18355	23.5	2000	131	3.55	M2511S	HJ15	HC15	Ø50-Ø450
N-220	Ø180	23	10.6	9177	23861	30.6	1800	190	6.5	ML2816	HJ24-1	HC24-1	Ø120-Ø510
N-224	Ø205	26	12	9177	23861	26.5	1400	270	14.8	ML3320	HJ24-1	HC24-1	Ø150-Ø610
N-232	Ø230	34	18	10197	24472	29.5	1200	470	41	ML3320	HJ24-1	HC24-1	Ø210-Ø800

DIM Model	A	B	C (H6)	D	H	J	K	L	M	N max.	O max.	O min.	P max.	P min.	Q	R	S	T	U max.	W	X	Y
N-204	110	59	85	14	70.6	16	3-M10x60	26	4	23.2	13.75	6.25	3.5	-6.5	2	10	17.5	23	M32x1.5	38	24	49.5
N-205	135	60	110	14	82.55	15	3-M10x60	33	4	26.5	19.75	7.75	1	-9	2	10	20	25	M40x1.5	44.5	31	62
N-206	169	81	140	20	104.78	16	6-M10x80	45	5	32	22.75	9.25	11	-1	2	12	19	31	M55x2	60	37	73
N-208	210	91	170	25	133.35	20	6-M12x90	52	5	38.7	29.75	11.75	14.5	-1.5	2	14	20.5	35	M60x2	66	38	95
N-210	254	100	220	30	171.45	22	6-M16x100	75	5	51.4	33.75	14.25	8.5	-10.5	2	16	25	40	M85x2	94	43	110
N-212	304	110	220	30	171.45	23	6-M16x110	91	6	61.3	45.75	15.75	8	-15	2	21	28	50	M100x2	108	51	130
N-215	381	133	300	43	235	30	6-M20x135	117.5	6	82	45.25	15.25	7	-16	5	22	43	62	M130x2	139	66	165
N-218	450	133	300	43	235	30	6-M20x135	117.5	6	82	79.75	15.25	7	-16	5	22	43	62	M130x2	139	66	165
N-220	510	134	380	60	330.2	35	6-M24x135	180	6	112.5	60.5	24.5	11	-12	5	25	38	64	M190x3	206	73	180
N-224	610	147	520	60	463.6	35	6-M24x150	205	6	131.9	87.5	24.5	16	-10	5	25	38	64	M215x3	230	73	180
N-232	800	150	520	60	463.6	35	6-M24x150	230	6	162	153.5	24.5	16	-18	5	25	38	64	M250x3	262	73	180



Product schematic

NT-200

2-jaw through-hole power chuck (adapter excluded)

1. Model NT2000 chucks are manufactured from high grade alloy steel. All sliding surfaces are hardened and ground for accurate actual running and long service repeatability. Lubrication nipple in each master jaw.
2. Base jaw : 1.5mmx60° serration.
3. Mounting : Adaptor mounting to fit with DIN, ISO, BS, ASA B5.9 type A spindles.

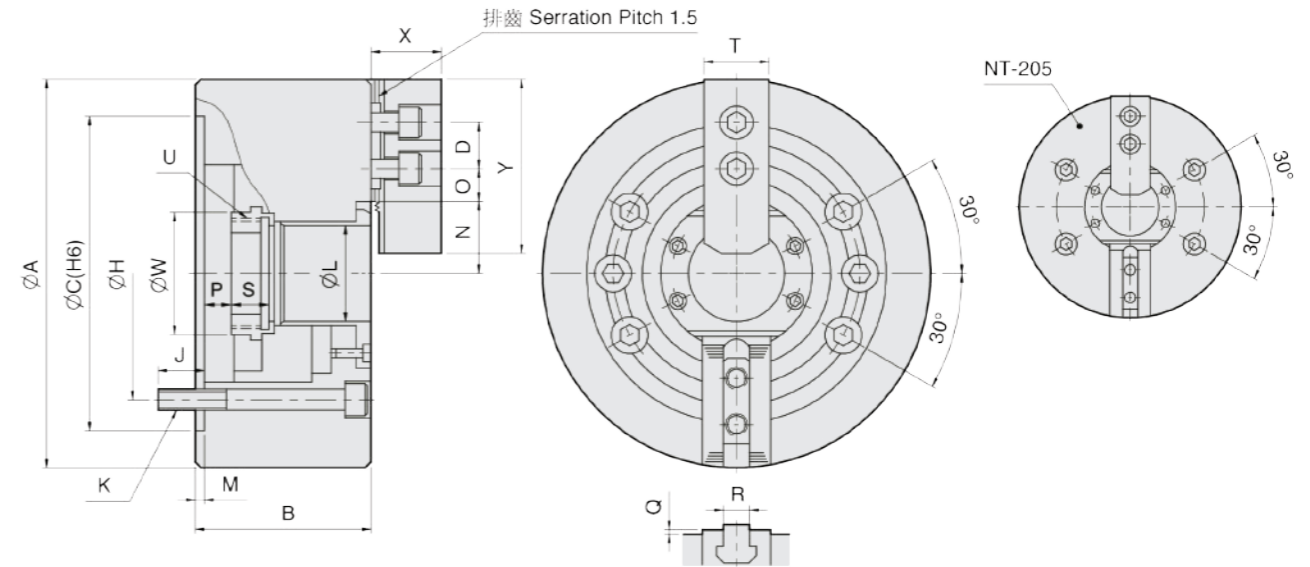

UNIT : mm

SPEC Model	Through-Hole (mm)	Plunger Stroke (mm)	Jaw Stroke (In Dia.) (mm)	Max. Pull Force (kgf)	Max. Gripping Force (kgf)	Max. Operating Pressure (kgf/cm ²)	Max. Speed (r.p.m.)	Weight (kg)	Moment Of Inertia I (kg·m ²)	Matching Cylinder	Matching Hard Jaw	Matching Soft Jaw	Gripping O.D. Range (mm)
NT-205	Ø33	10	5.4	1189	2447	19.5	7000	6.8	0.017	M1036	HJ05	HC05	Ø6-Ø135
NT-206	Ø45	12	5.5	1495	3875	18.9	6000	12.8	0.054	M1246	HJ06	HC06	Ø15-Ø169
NT-208	Ø52	16	7.4	2366	5975	18.4	5000	22	0.163	M1552	HJ08	HC08	Ø20-Ø210
NT-210	Ø75	19	8.8	2927	7546	18.4	4200	34	0.306	M1875	HJ10	HC10	Ø25-Ø254
NT-212	Ø91	23	10.6	3875	9993	18.4	3300	55	0.717	M2091	HJ12	HC12	Ø30-Ø304
NT-215	Ø117.5	23	10.6	4823	12236	15.3	2500	106	2.17	M2511S	HJ15	HC15	Ø50-Ø381
NT-218	Ø117.5	23	10.6	4823	12236	15.3	2000	122	3.31	M2511S	HJ15	HC15	Ø50-Ø450

DIM Model	A	B	C (H6)	D	H	J	K	L	M	N max.	O max.	O min.	P max.	P min.	Q	R	S	T	U max.	W	X	Y
NT-205	135	60	110	14	82.55	15	4-M10x60	33	4	26.5	19.75	7.75	1	-9	2	10	20	25	M40x1.5	44.5	31	62
NT-206	169	81	140	20	104.78	16	6-M10x80	45	5	32	22.75	9.25	11	-1	2	12	19	31	M55x2	60	37	73
NT-208	210	91	170	25	133.35	20	6-M12x90	52	5	38.7	29.75	11.75	14.5	-1.5	2	14	20.5	35	M60x2	66	38	95
NT-210	254	100	220	30	171.45	22	6-M16x100	75	5	51.4	33.75	14.25	8.5	-10.5	2	16	25	40	M85x2	94	43	110
NT-212	304	110	220	30	171.45	23	6-M16x110	91	6	61.3	45.75	15.75	8	-15	2	21	28	50	M100x2	108	51	130
NT-215	381	133	300	43	235	30	6-M20x135	117.5	6	82	45.25	15.25	7	-16	5	22	43	62	M130x2	139	66	165
NT-218	450	133	300	43	235	30	6-M20x135	117.5	6	82	79.75	15.25	7	-16	5	22	43	62	M130x2	139	66	165