

UFO Family Common Toolholders

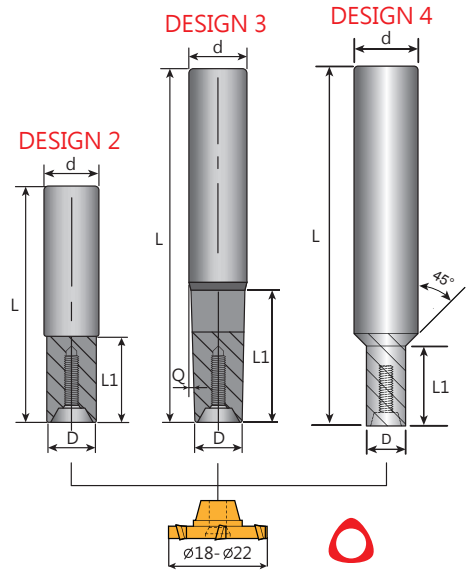

CB3

• HSS Shanks

Order code	Dimensions (mm)					Design	KG	Inserts	Screw	Key
	D	d	L	L1	Q					
CB3-1010-80-20	9.8	10	80	12	-	2	ø 18 ø 19 ø 20 ø 21 ø 22	C03513	T10P	
CB3-1010-100-20			100							
CB3-1210-90-20		12	90	25	3.2°					
CB3-1210-130-20			130	40	1.7°					
CB3-1610-90-20	11.8	16	90	20	-	4	C03513	T10P		
CB3-1612-95-20			95	25	-	4				
CB3-1612-150-20			150	55	2.4°	3				
CB3-1616-150-20				20	-	2			0.31	

CB3W

• Carbide Shanks

Order code	Dimensions (mm)					Design	KG	Inserts	Screw	Key
	D	d	L	L1	Q					
CB3W-1010-100-20	9.8	10	100	12	-	2	0.18	ø 18 ø 19 ø 20 ø 21 ø 22	C03513	T10P
CB3W-1212-150-20	11.8	12	150	20	-	2	0.32			

• To check the max. AR, please refer to the page of relative inserts or cutters.