

A STRONGHOLD BY PRECISION AND POWER.



DI CHUN IRON WORK CO., LTD.

NO. 7, Jingke 1st Rd., Nantun Dist.,
Taichung City 408, Taiwan
Tel: +886-4-2358-5879 Fax: +886-4-2358-3695
www.auto-strong.com



AUTO
Strong

Di Chun Spirit — Our Heart is to be Tolerant of Diversity.





CONTENTS



A STRONGHOLD BY PRECISION AND POWER.

P15 Scroll / Chuck Jaw Chuck



KD
3-jaw strong scroll chuck
D1 camlock direct mounting,
2-piece jaws.



NT-200
2-jaw through-hole power chuck.
(adapter excluded)

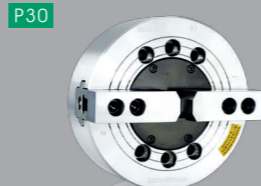

VT&VIT
2-jaw and 4-jaw wedge type
non through-hole power chuck.
(adapter excluded)

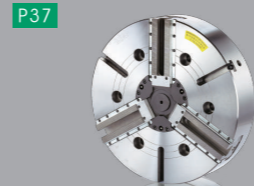

V-300RA
Non through-hole power chuck
for vertical lathe.
(adapter included)



M
High speed through-hole
rotary hydraulic cylinder.



MS
Non through-hole rotary hydraulic
cylinder.(valve included)

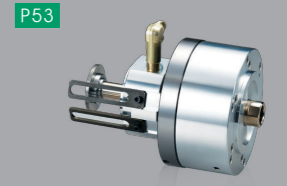

MRR
Short type non through-hole
rotary hydraulic cylinder.
(for rotary union)



SC
3-jaw scroll chuck plain
back, solid jaws.



SE
6-jaw scroll chuck plain back.



NIT-200
4-jaw through-hole power chuck.
(adapter excluded)

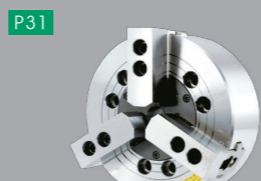

VA
3-jaw wedge type non
through-hole power chuck.
(adapter included)

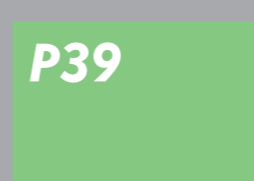

P39 Collet Chuck



MK
Super high speed through-hole
compact rotary hydraulic cylinder.

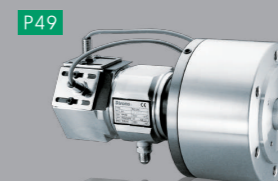

MS-C
Non through-hole rotary hydraulic
cylinder.(valve and switch brackets
included)

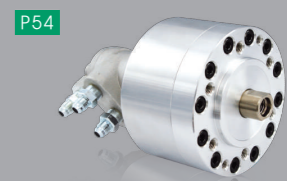

MH-F
Non through-hole rotary hydraulic
cylinder.



SIC
4-jaw scroll chuck plain
back, solid jaws.

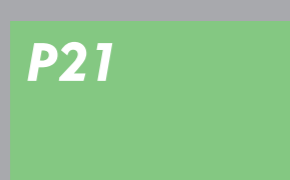

P21 Power Chuck



NHT-200
2 jaw and 3 jaw through-hole
power chuck. (adapter included)



V(40"-79")
Large wedge type non
through-hole power chuck.
(adapter excluded)



CR
Collet chuck for cylindrical
center mount.



CM.B
Hydraulic cylinder coolant collector.



MS250C/MS300C
Non through-hole rotary hydraulic
cylinder.(valve and switch brackets
included)

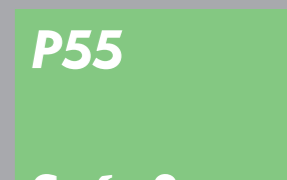

P55 Soft & Hard Jaws



SK
3-jaw strong scroll chuck
plain back, 2-piece jaws.



N-200A
3-jaw through-hole power chuck.
(adapter included)



NB-200A
3-jaw extra large through-hole
power chuck. (adapter included)



DV/DN
Vertical and vertical horizontal
stationary power chuck.



CRA
Collet chuck for short taper
mount.



ML-CM.B
Extra large through-hole rotary
hydraulic cylinder.



MR
Short type non through hole
rotary hydraulic cylinder.

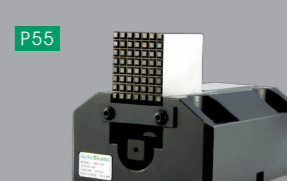

HB4
Boring mill jaw.



SIK
4-jaw strong scroll chuck
plain back, 2-piece jaws.



N-200
3-jaw through-hole power chuck.
(adapter excluded)



V
3-jaw wedge type non
through-hole power chuck.
(adapter excluded)



VRA
Non through-hole power chuck for
vertical lathe. (adapter included)



P41 Hydraulic Cylinder



MM
High speed and compact
through-hole rotary hydraulic cylinder.



MRA
Short type non through-hole
rotary hydraulic cylinder
with central bore for air.



SKC
Soft jaw for strong scroll chuck.



P57
HC
Soft jaw for hydraulic power chuck.



P62
T-UNTS
Suitable for power chuck.



P66
NL-A
3-jaw long stroke through-hole power chuck.(adapter included)



P71
SB-ES
Pneumatic power chuck.



P59
HC40-1
Soft jaw for hydraulic power chuck.

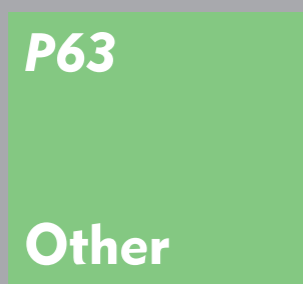

P67
BL
3-jaw ball swing lock chuck.



P72
PB-ES
Pneumatic power chuck.



HJ40-1
Hard jaw for hydraulic power chuck.

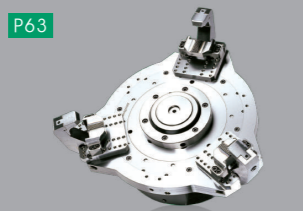

P63
F52
High speed and light weight type strong finger chuck for aluminum wheel.



P68
DR
3-jaw draw down power chuck.



P60
HJ
Hard jaw for hydraulic power chuck.



P64
F61
High speed and light weight type strong finger chuck for aluminum wheel.



P69
P165
Floating plate center chuck.

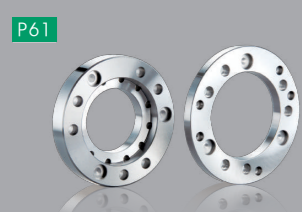

P61
ADAPTER
Mounting adapter on short taper spindle noses DIN55026.

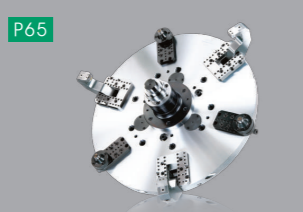

P65
F66
High speed and light weight type strong finger chuck for aluminum wheel.

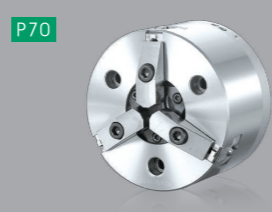

P70
HN
3-jaw extra high speed through-hole power chuck.(adapter included)



Customer First, Employee's Need, It is Di Chun's Core Value of Management.

A sincere enterprise that is worthy to trust-Di Chun. Traditional spirit, innovative technology; people-oriented and treat them as family; solid our career in Taiwan and exploring the world.

Past 40 years, Di Chun insists the spirit of "Quality to be the must and customer must to be the first; do the right thing; seeking the truth and finding the cause" applied to manufacturing various kind of accurate products. We rapidly rose from small or medium-sized companies and factories, but today we are wide continuously recognized and have been honored by supplying worth-trust machine tool equipment to many users.

Di Chun expanded in 1992 and established the brand "Auto Strong" which has a meaning of being precise and strong as eagle's claw, in order to emphasize the quality and high performance of Di Chun products, this is our value to focus on research, development and innovation, solid our career in Taiwan then head to the international machine tool equipment market; meanwhile, the precise production process were compliments by our customers.

Until now, Di Chun not only insist strict quality control, but emphasize the six policies of "personal cultivating, innovation constantly, flexible thinking, uplift the career, global vision, outstanding products" symbolizes the contemplation of Di Chun "Head to the global market and Taiwan will be known everywhere."

The competition advantage is the capital for most business, but what support Di Chun to sustainable development is a team united as a strong family. We insist a concept of "tolerance diversity, placing every employee to the right position", in order to advance the ability, we create a comfortable working environment, training them to be specialist and share the profit together. There is an ancient Chinese saying: "If people's hearts together, the great mountain can be moved", Di Chun policy is based on traditional Taiwanese spirits which is serious and responsible, and completely reflected the best quality of "Made in Taiwan".

Di Chun represents the culture of "people-oriented" and participate this policy in various aspects: "Traditional spirits, based on honor, reliable quality; new concepts, understanding the trend of the world; advanced technology, research innovative, challenge beyond the limit."

Today, Di Chun persists developing product perfect than ever not only by approved by ISO & CE, but severe self-demanding, This is what we perform and doubtless we have confidence that we are going to be the top one machine tool equipment manufacturer in the future.

This is Di Chun, create miracles, worth trusting.

Innovation is recorded by time

Di Chun is proud of its achievement today, but not complacent, because every step along the way was hard, these were earned carefully.

Besides treasuring what we have now, also remind ourselves through the past experience. Challenge our limit at every moment. Let innovation is recorded by time.



- 1970**
 - 1974 Established Yong Yu Machinery Factory on Zhenxing Rd. in Taichung, and manufactured 3-jaw scroll chucks professionally.
 - 1976 Quality was affirmed by the machine tool maker, and 3-jaw scroll chucks started being mass produced.
 - 1977 The group changed and established Di Chun Iron Work Co., LTD., and expanded business by relocating the factory to Yonghe St. in Taichung City. The R&D Department was established, and a range of interchangeable chuck jaws for hydraulic chucks were successfully developed.
 - 1978 Purchased CNC lathes and Machining Centers, production becomes fully automated.
- 1980**
 - 1980 Cooperated with ONO Machine & Tool Co. Ltd., as a joint venture, and successfully entered into the Japanese market.
 - 1982 Researched and developed special purpose precision drilling machine and entered into the business operations.
 - 1984 The operation of the whole factory was upgraded to computerized data management.
 - 1987 Along with the government, the strategic components strategic standards were promoted and also entered into the research of jaws for CNC lathe chucks.
 - 1988 Successfully researched and developed hydraulic 3-jaw scroll chucks and super high-speed rotary hydraulic cylinders for CNC lathes in cooperation with the Mechanical and Systems Research Laboratories of Industrial Technology Research Institute.
- 1990**
 - 1991 Awarded the approval of MCS (Mechanical Component Standard) certification.
 - 1992 Expanded the company's operations, and increased the capital to NT\$ 50 million, and relocated to Wu Jih Factory. Entered into the international automation equipment market.
 - 1993 Established Beijing and Shenyang offices in mainland China. Promoted total quality control. Adopted 100% Meehanite for the main body of the 3-jaw scroll chucks.
 - 1995 Passed the CE (Conformité Européenne) marking certification. The company officially changed the Chinese name to Di Chun Iron Work Co., LTD. (the English name remained the same). Products honored with Golden Tripod Award by the Air/Oil Hydraulic Society.
 - 1996 Passed the ISO-9002 Quality Assurance System certification.
 - 1997 Researched and developed the following items: M2511 high-speed rotary hydraulic cylinders (15"), MS Non through-hole rotary hydraulic cylinders with built-in safety device, MSC Non through-hole rotary hydraulic cylinders with built-in safety & detection device, and CT42 precision collet chucks.
 - 1998 Researched and developed: V218 Non through-hole hydraulic chucks.
 - 1999 Researched and developed: V244 Non through-hole hydraulic chucks.
- 2000**
 - 2000 Researched and developed: finger chucks for aluminum wheels.
 - 2001 Researched and developed: MM0933 and MM1033 through-hole rotary hydraulic cylinders.
 - 2002 Researched and developed in June: HN06 ten thousand rpm hydraulic chucks and HG296 ten thousand rpm hydraulic cylinders. Passed the ISO-9001 Quality Assurance System certification in September.
 - 2003 Researched and developed: HB4 boring mill, P165 floating plate center chuck, and N204- and NB-series extra-large through-hole chucks.
 - 2004 Expanded the factory complex. Researched and developed: DR-series draw down chucks and BL-series ball swing lock chucks.
 - 2005 Researched and developed: F52 12"~18" finger chucks for aluminum wheels.
 - 2006 Researched and developed: F61 13"~22" and F66 17"~24" finger chucks for aluminum wheels.
 - 2007 Researched and developed: V240(1000mm) Non through-hole hydraulic chucks and MS250C Non through-hole rotary hydraulic cylinders.
 - 2008 Researched and developed: V250(1250mm) Non through-hole hydraulic chuck and VE263(1600mm) extra-large vertical lathe Non through-hole chucks.
 - 2009 Researched and developed: ML-2816 extra-large through-hole rotary hydraulic cylinders.
- 2010**
 - 2010 Researched and developed: ML-3320 extra-large through-hole rotary hydraulic cylinders.
 - 2011 Researched and developed: VE 279(2000mm) Non through-hole hydraulic chucks and MS300C Non through-hole rotary hydraulic cylinders.
 - 2012 Researched and developed: PB-ES600-275 pneumatic power chucks and MR250 Non through-hole compact rotary hydraulic cylinders.
 - 2013 Researched and developed: PB-ES850-375 pneumatic power chucks and the factory was relocated to Precision Machinery Park to expand its operations.
 - 2014 Researched and developed: VE 298(2500mm) Non through-hole hydraulic chucks.
 - 2015 Researched and developed: V3R-series(V312R~V332R) Non through-hole power chuck for vertical lathe (adapter included).
 - 2016 Researched and developed: NL-series(NL-06、NL-08、NL-10) 3-jaw long stroke through-hole power chuck (adapter included).



A STRONGHOLD BY PRECISION AND POWER.

Precise Manufacturing Process

Chuck is the main component of the lathe; it's not only lightweight and resilient, but also stable and solid. Di Chun always insist traditional principle: "Quality Stabilized", "Energy Efficiency", "Standard specification", and fully understand the trend of the world, in order to transcend the limit of our manufacture process, which based on innovative ideas and advanced technology.

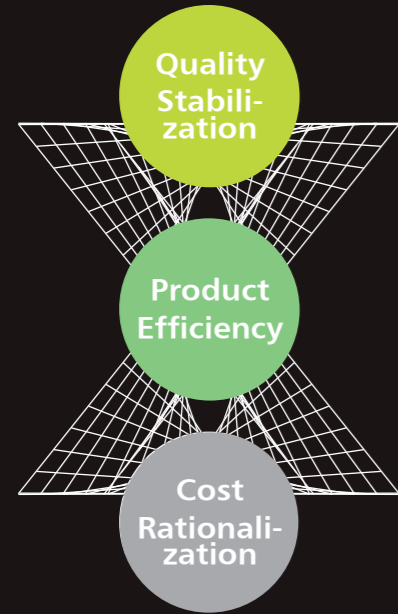

Product Advantages

- It is smaller and lighter than the regular products, and it is more stable during high speed rotation, reduce the spindle loading.
- Manufactured by aluminum alloy, it is lightweight, the machine can elaborate its features, and equipped with a safety lock mechanism.
- Parts standardization, high-speed, high clamping force, easy to assemble operation, and durable.
- Low noise, pollution-free.



Strict Quality Control

Even the precise manufacturing process still need the strict quality control, Di Chun does not only get several domestic rewards, but also approved by CE & ISO-9001 certifications. Di Chun insists its quality control through the tool of IMPACT Three Dimensional Testing and TESA Height Gauge to offer the best product to customers.



A STRONGHOLD BY PRECISION AND POWER.

“Auto Strong” Well-known Reputation over 20 Years

20 years ago, when most Taiwanese enterprises which making a decision between OEM, ODM or OBM, Di Chun already insight for developing its own brand, “AUTO STRONG” was established by creativity and innovation. Di Chun has possessed 70% domestic market and become the pioneer beyond its competitors during a decade. These achievements are created by all Di Chun members together.

Di Chun’s foundation is based on our professional team work. In 1995, Di Chun was ahead of competitors to entering the European market by CE certification and domestic award. Di Chun, a world- class factory, a symbol of good quality and a professional developing create the reliable product worldwide such as Great Britain, United States, Germany, Italy, China, Thailand, Indonesia, Malaysia, Japan, Brazil, Soviet Union, Singapore and get good reputation from them.

Marketing construction and sales network built by professional team and become the pioneer among the realm of machine tool equipment manufacturing. Besides, Auto Strong products focus not only on high quality, but excellence.

Even global changed itself rapidly, Di Chun insist one policy, developing new product, display our highly efficiency and professional, and create our value to the top level. Auto Strong, as precise as eagle’s claw, is what Di Chun shows and captures customer’s hearts.

Di Chun, create miracles, worth trusting.



SC

3-jaw scroll chuck plain back, solid jaws (front and back mounted)

1. Interchangeable utilization of internal and external hard jaws.
2. SC types feature economical and durable, suitable for mass production.
3. Gripping accuracy of 0.03mm (0.0012 inch) T.I.R..
4. The body is made of MEEHANITE. It is suitably used for high speed revolution and 3 times more durable than regular material.

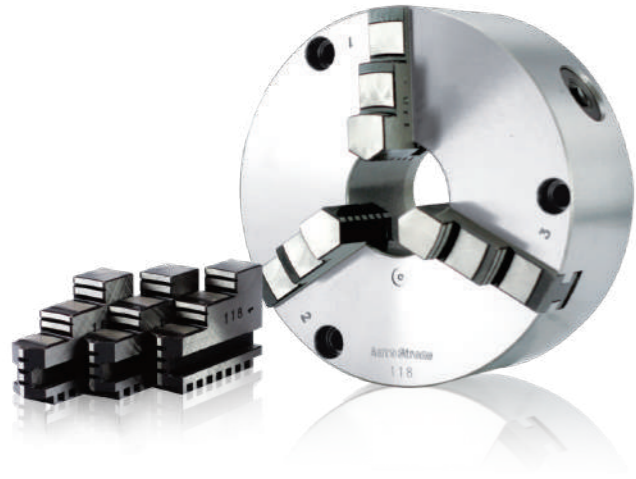

Product schematic

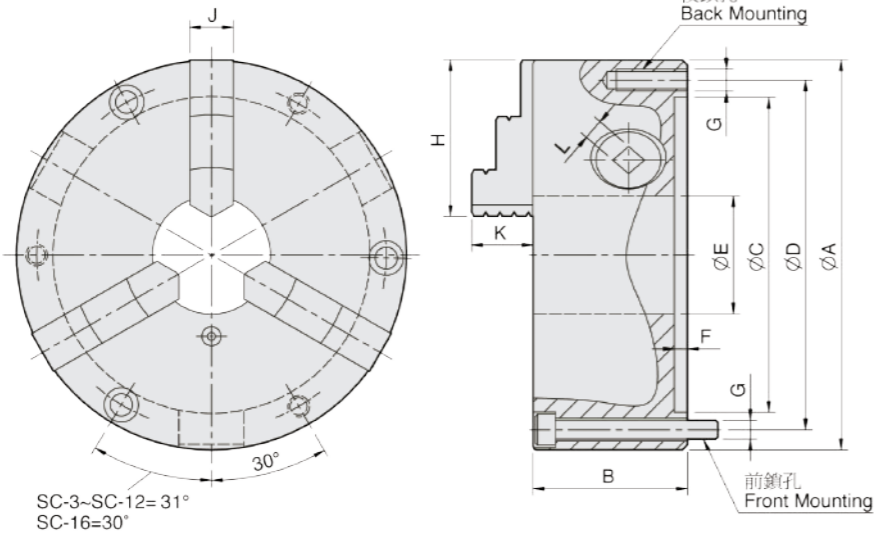

SIC

4-jaw scroll chuck plain back, solid jaws (front and back mounted)

1. Gripping of square or octagonal workpieces could fit into central line automatically.
2. SIC have high stability in gripping thin tube work piece.
3. The specification is the same as SC type.
4. The body is made of MEEHANITE. It is suitably used for high speed revolution and 3 times more durable than regular material.



Product schematic

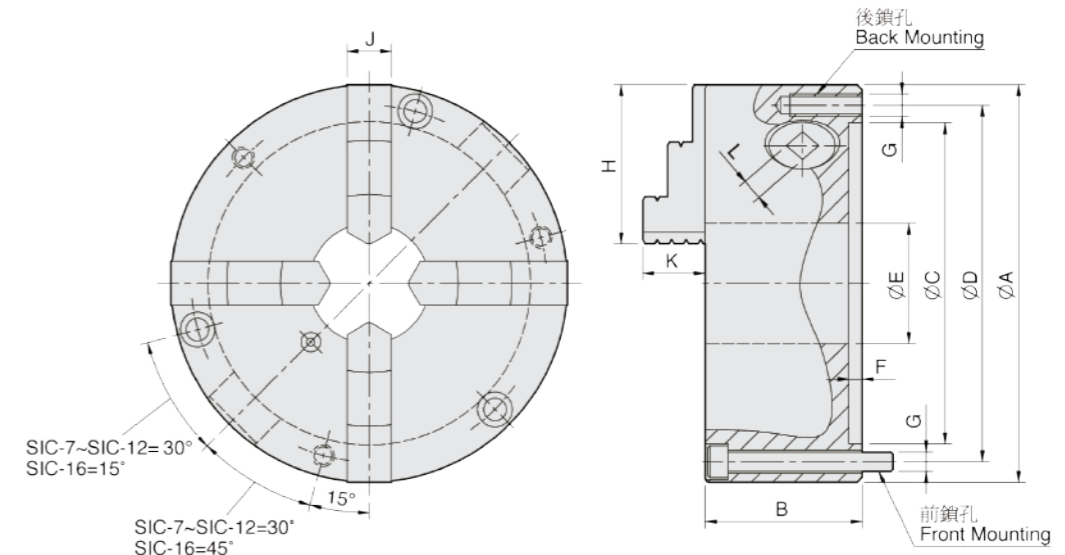

UNIT : mm

SPEC Model	A	B	C	D	E	F	G Back / Front	H	J	K	L	Allowable Handle Torque (kgf·m)	Gripping Force (kgf)	Max. Speed (r.p.m.)	Weight (kg)	Moment Of Inertia I (kg·m²)	Gripping Range O.D. Range / I.D. Range
SC-3	86	46	60	73	16	4.1	3-M6 / 3-M6x50	36	11	14.3	7	3.0	900	2500	1.7	—	Ø2-Ø70 / Ø24-Ø64
SC-4	112	60	80	95	24	4.8	3-M8 / 3-M8x70	42	14	16.6	8	4.5	1200	2500	3.7	—	Ø3-Ø95 / Ø29-Ø84
SC-5	132	60	100	115	32	4.8	3-M8 / 3-M8x70	50	16	20.3	8	6.5	1500	2500	5.2	0.01	Ø3-Ø110 / Ø33-Ø100
SC-6	167	67	130	147	45	5.5	3-M10 / 3-M10x70	63	19	23.7	10	9.0	2200	2000	9.3	0.03	Ø4-Ø160 / Ø48-Ø150
SC-7	192	76.5	155	172	58	5.5	3-M10 / 3-M10x80	77	21.5	29.4	11	11.0	2500	2000	14.2	0.06	Ø4-Ø180 / Ø56-Ø170
SC-8	200	76.5	160	176	58	5.5	3-M10 / 3-M10x80	77	21.5	29.4	11	11.0	2500	2000	16	0.07	Ø4-Ø190 / Ø62-Ø180
SC-9	232	84	190	210	70	6	3-M12 / 3-M12x90	87	24	35.6	12	15.0	3000	2000	22.7	0.15	Ø5-Ø220 / Ø62-Ø210
SC-10	273	87	230	250	89	8	3-M12 / 3-M12x90	98	28	39.5	12	19.5	4000	1800	31.8	0.25	Ø6-Ø260 / Ø70-Ø250
SC-12	310	96	260	285	105	7	3-M12 / 3-M12x110	110	30	45.6	14	21.0	4200	1800	44.8	0.58	Ø10-Ø300 / Ø86-Ø290
SC-16	405	122	345	375	160	8.7	— / 6-M14x130	146	42	56.3	15	25.0	4500	1500	102	1.75	Ø30-Ø380 / Ø110-Ø360

UNIT : mm

型式規格	A	B	C	D	E	F	G Back / Front	H	J	K	L	Allowable Handle Torque (kgf·m)	Gripping Force (kgf)	Max. Speed (r.p.m.)	Weight (kg)	Moment Of Inertia I (kg·m²)	Gripping Range O.D. Range / I.D. Range
SIC-7	192	76.5	155	172	58	5.5	3-M10 / 3-M10x80	77	21.5	29.4	11	11.0	2500	2000	14.8	0.06	Ø4-Ø180 / Ø56-Ø170
SIC-9	232	84	190	210	70	6	3-M12 / 3-M12x90	87	24	35.6	12	15.0	3000	2000	23.2	0.16	Ø5-Ø220 / Ø62-Ø210
SIC-12	310	96	260	285	105	7	3-M12 / 3-M12x110	110	30	45.6	14	21.0	4200	1800	47	0.58	Ø10-Ø300 / Ø86-Ø290
SIC-16	405	122	345	375	160	8.7	— / 6-M14x130	146	42	56.3	15	25.0	4500	1500	107	1.72	Ø30-Ø380 / Ø110-Ø360

SK

3-jaw strong scroll chuck plain back, 2-piece jaws (front and back mounted)

1. SK types chucks have wider utilization range; hard jaws suitable for heavy cutting; soft jaws suitable for light and precision cutting.
2. Hard jaws could be used as internal jaws and external jaws.
3. Gripping accuracy of 0.03mm (0.0012 inch) T.I.R.
4. The body is made of MEEHANITE. It is suitably used for high speed revolution and 3 times more durable than regular material.



Product schematic

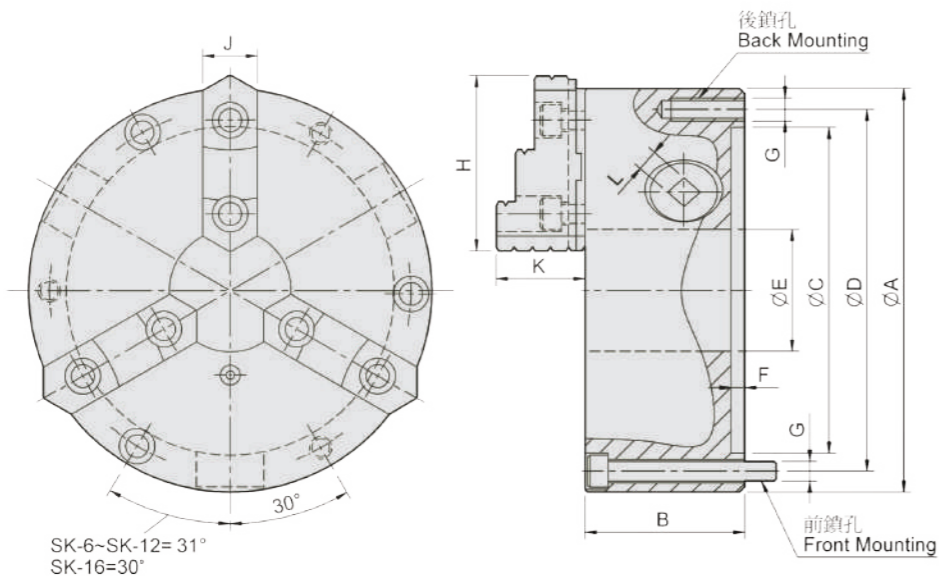

SIK

4-jaw strong scroll chuck plain back, 2-piece jaws (front and back mounted)

1. Hard jaws are adopted for square or octagonal thin tube workpieces machining.
2. Soft jaws could grip rectangular workpiece after being anisotropic machined.
3. The specification is the same as SK type.
4. The body is made of MEEHANITE. It is suitably used for high speed revolution and 3 times more durable than regular material.



Product schematic

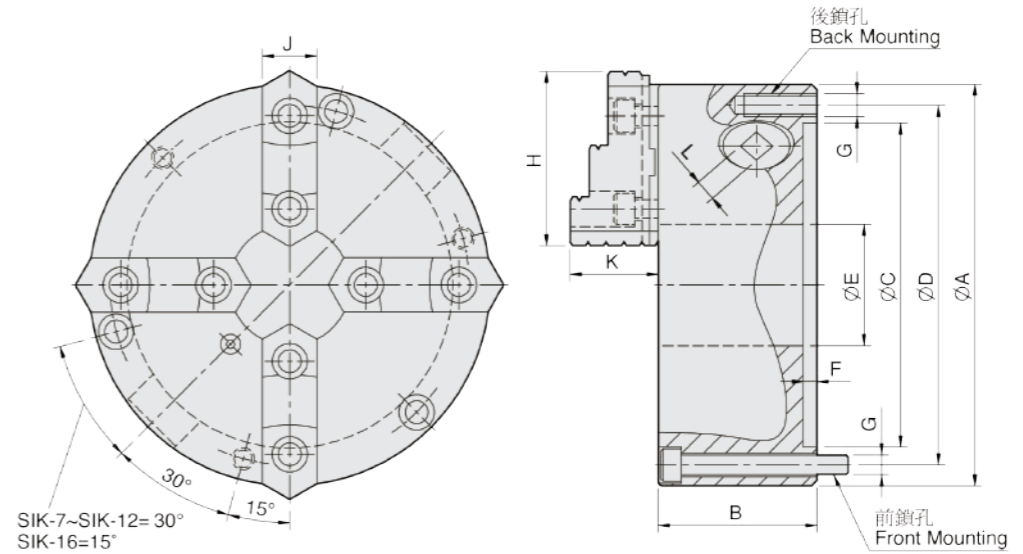

UNIT : mm

SPEC Model	A	B	C	D	E	F	G Back / Front	H	J	K	L	Allowable Handle Torque (kgf · m)	Gripping Force (kgf)	Max. Speed (r.p.m.)	Weight (kg)	Moment Of Inertia I (kg · m ²)	Gripping Range O.D. Range / I.D. Range
SK-4	112	58	80	95	32	4.8	3-M8 / 3-M8x65	47	19	31.6	8	4.5	1200	2500	3.8	—	Ø3-Ø95 / Ø34-Ø90
SK-6	167	67	130	147	45	5.5	3-M10 / 3-M10x70	72	26	40.2	10	9.0	2200	2000	9	0.03	Ø4-Ø160 / Ø55-Ø150
SK-7	192	76.5	155	172	58	5.5	3-M10 / 3-M10x80	81.2	28	42	11	11.0	2500	2000	13.8	0.06	Ø8-Ø180 / Ø62-Ø170
SK-8	200	76.5	160	176	58	5.5	3-M10 / 3-M10x80	82	28	42	11	11.0	2500	2000	15.5	0.07	Ø8-Ø190 / Ø68-Ø180
SK-9	232	84	190	210	70	6	3-M12 / 3-M12x90	90.9	32	51.2	12	15.0	3000	2000	22	0.16	Ø11-Ø220 / Ø70-Ø210
SK-10	273	87	230	250	89	8	3-M12 / 3-M12x90	100.5	35	56.7	12	19.5	4000	1800	29.7	0.26	Ø12-Ø260 / Ø80-Ø250
SK-12	310	96	260	285	105	7	3-M12 / 3-M12x110	114.5	40	56.8	14	21.0	4200	1800	43.5	0.58	Ø15-Ø300 / Ø90-Ø290
SK-16	405	122	345	375	160	8.7	— / 6-M14x130	148.6	50	76.1	15	25.0	4500	1500	98	1.72	Ø30-Ø380 / Ø110-Ø360

UNIT : mm

SPEC Model	A	B	C	D	E	F	G Back / Front	H	J	K	L	Allowable Handle Torque (kgf · m)	Gripping Force (kgf)	Max. Speed (r.p.m.)	Weight (kg)	Moment Of Inertia I (kg · m ²)	Gripping Range O.D. Range / I.D. Range
SIK-7	192	76.5	155	172	58	5.5	3-M10 / 3-M10x80	82	28	42	11	11.0	2500	2000	14.1	0.06	Ø8-Ø180 / Ø62-Ø170
SIK-9	232	84	190	210	70	6	3-M12 / 3-M12x90	96	32	51.2	12	15.0	3000	2000	22.2	0.16	Ø11-Ø220 / Ø70-Ø210
SIK-12	310	96	260	285	105	7	3-M12 / 3-M12x110	114.5	40	56.8	14	21.0	4200	1800	45	0.58	Ø15-Ø300 / Ø90-Ø290
SIK-16	405	122	345	375	160	8.7	— / 6-M14x130	148.6	50	76.1	15	25.0	4500	1500	108	1.72	Ø30-Ø380 / Ø110-Ø360



KD

3-jaw strong scroll chuck D1 camlock direct mounting, 2-piece jaws

1. Gripping accuracy of 0.03mm (0.0012 inch) T.I.R..
2. Standard accessories chuck wrench, hex. key. and a set of mounting bolts. (UNC-bolts)
3. The body is made of MEEHANITE. It is suitably used for high speed revolution and 3 times more durable than regular material.

Product schematic

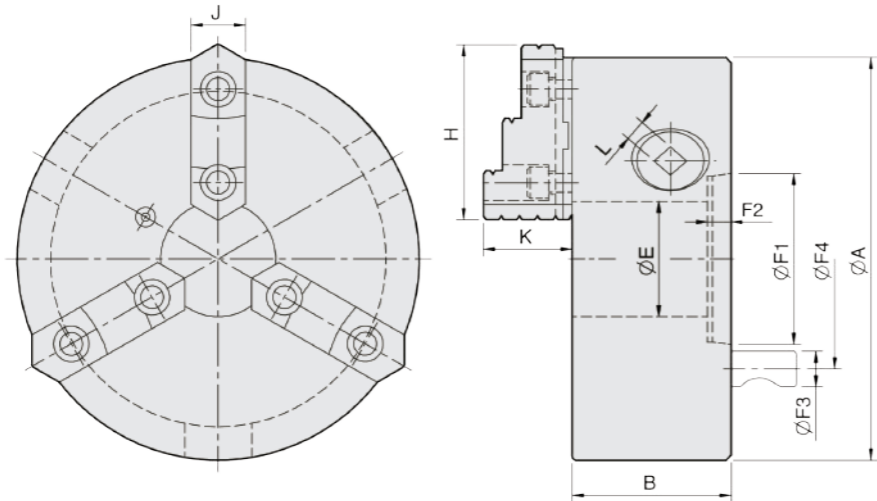

SE

6-jaw scroll chuck plain back

1. SE types are specially meet for drilling*endmilling*tapping or grinding in tool grinders.
2. Huge bore diameter design for wider application of bar workpieces.
3. SE type feature gripping for thin tube and high roundness accuracy.
4. The body is made of MEEHANITE. It is suitably used for high speed revolution and 3 times more durable than regular material.

Product schematic

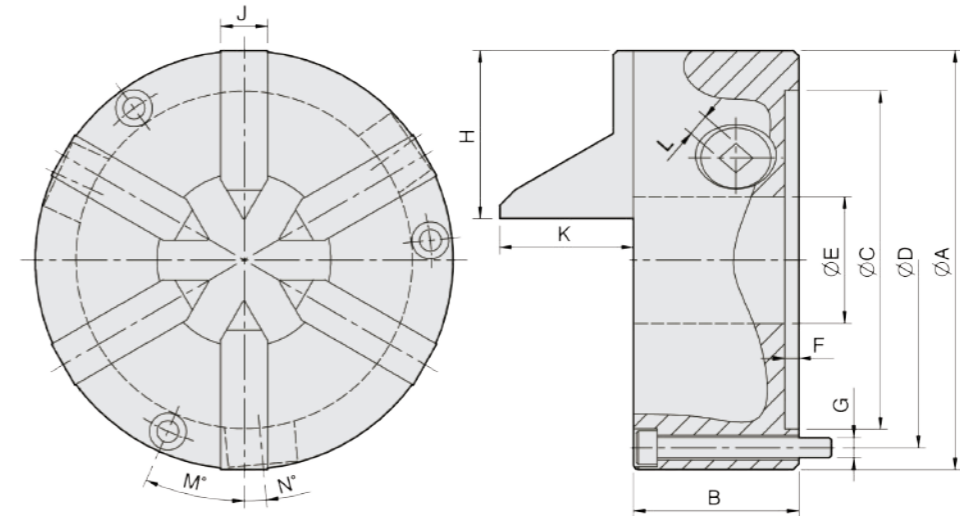

UNIT : mm

SPEC Model	Spindle Size	A	B	E	H	J	K	L	Mounting Dimensions				Allowable Handle Torque (kgf · m)	Gripping Force (kgf)	Max. Speed (r.p.m.)	Weight (kg)	Moment Of Inertia I (kg · m²)	Gripping Range O.D. Range / I.D. Range
									F1	F2	F3	F4						
KD4-8"	D1-4	200	77.2	53	82	28	42.2	11	63.513	13	15.8	82.55	11.5	2500	2000	18.5	0.07	Ø8-Ø180 / Ø62-Ø170
KD5-8"	D1-5	200	77.2	55	82	28	42.2	11	82.563	16	19	104.78	11.5	2500	2000	18	0.07	Ø8-Ø180 / Ø62-Ø170
KD6-8"	D1-6	200	77.2	58	82	28	42.2	11	106.375	17	22.2	133.35	11.5	2500	2000	17	0.07	Ø8-Ø180 / Ø62-Ø170
KD6-10"	D1-6	250	86	76	90.9	32	50.8	12	106.375	17	22.2	133.35	19.5	4000	1800	29.5	0.2	Ø11-Ø220 / Ø70-Ø210
KD6-12"	D1-6	306	107.5	103	114.5	40	57.8	14	106.375	13.5	22.2	133.35	21.0	4200	1800	47	0.5	Ø15-Ø300 / Ø90-Ø290
KD8-10"	D1-8	250	86	80	90.9	32	50.8	12	139.719	19	25.4	171.45	19.5	4000	1800	27	0.2	Ø11-Ø220 / Ø70-Ø210
KD8-12"	D1-8	306	107.5	103	114.5	40	57.8	14	139.719	18	25.4	171.45	21.0	4200	1800	47	0.5	Ø15-Ø300 / Ø90-Ø290

UNIT : mm

SPEC Model	A	B	C	D	E	F	G	H	J	K	L	M	N	Allowable Handle Torque (kgf · m)	Gripping Force (kgf)	Max. Speed (r.p.m.)	Weight (kg)	Moment Of Inertia I (kg · m²)	Gripping O.D. Range
SE-6	165	67	130	147	51	5.5	3-M8x70	66.5	19	40.7	10	23.3	6.2	2.8	660	1200	9	0.03	Ø3-Ø51
SE-7	192	76.5	155	172	80	5.5	3-M10x75	77	21.5	61.5	11	24	5.3	3.6	850	1000	14	0.06	Ø3-Ø80



N-200A

3-jaw through-hole power chuck (adapter included)

- Model N-200A chucks are assembled with adaptor for ASA B5.9 type A spindles.

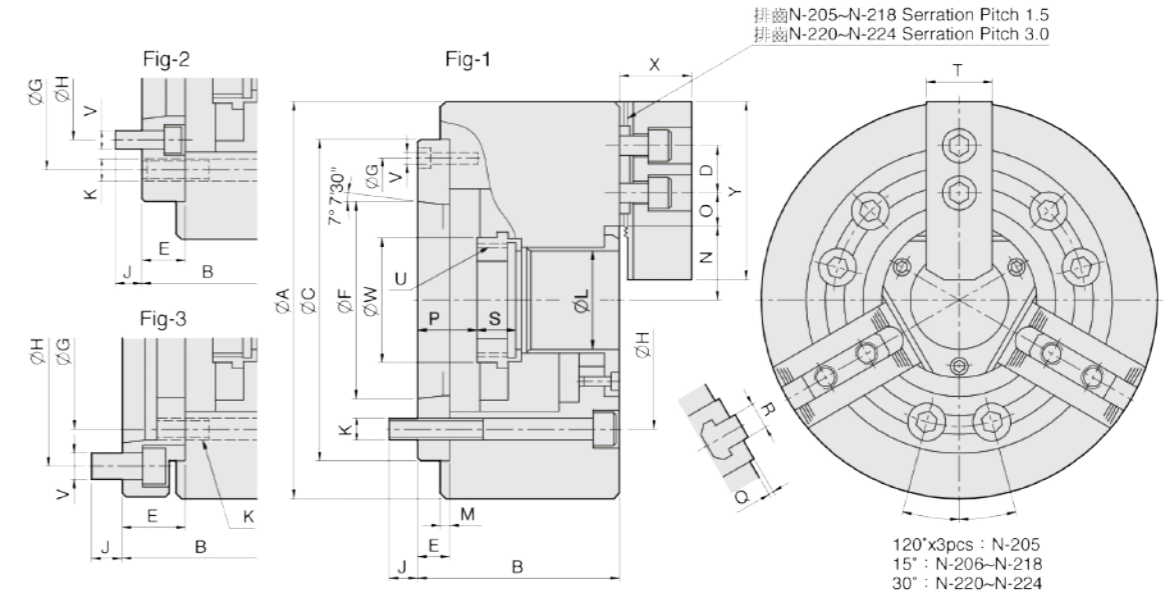

UNIT : mm

SPEC Model	Through-Hole (mm)	Plunger Stroke (mm)	Jaw Stroke (In Dia.) (mm)	Max. Pull Force (kgf)	Max. Gripping Force (kgf)	Max. Operating Pressure (kgf/cm ²)	Max. Speed (r.p.m.)	Weight (kg)	Moment Of Inertia I (kg·m ²)	Matching Cylinder	Matching Hard Jaw	Matching Soft Jaw	Gripping O.D. Range (mm)
N-205A4	Ø33	10	5.4	1784	3671	28.5	7000	7.8	0.020	M1036	HJ05	HC05	Ø6-Ø135
N-205A5	Ø33	10	5.4	1784	3671	28.5	7000	9	0.023	M1036	HJ05	HC05	Ø6-Ø135
N-206A4	Ø45	12	5.5	2243	5812	28.5	6000	15.5	0.065	M1246	HJ06	HC06	Ø15-Ø169
N-206A5	Ø45	12	5.5	2243	5812	28.5	6000	14.7	0.062	M1246	HJ06	HC06	Ø15-Ø169
N-206A6	Ø45	12	5.5	2243	5812	28.5	6000	17.3	0.073	M1246	HJ06	HC06	Ø15-Ø169
N-208A5	Ø52	16	7.4	3558	9075	26.5	5000	25.8	0.190	M1552	HJ08	HC08	Ø20-Ø210
N-208A6	Ø52	16	7.4	3558	9075	26.5	5000	25	0.184	M1552	HJ08	HC08	Ø20-Ø210
N-208A8	Ø52	16	7.4	3558	9075	26.5	5000	29.3	0.217	M1552	HJ08	HC08	Ø20-Ø210
N-210A6	Ø75	19	8.8	4385	11319	27.5	4200	41	0.370	M1875	HJ10	HC10	Ø25-Ø254
N-210A8	Ø75	19	8.8	4385	11319	27.5	4200	38	0.340	M1875	HJ10	HC10	Ø25-Ø254
N-210A11	Ø75	19	8.8	4385	11319	27.5	4200	48.4	0.436	M1875	HJ10	HC10	Ø25-Ø254
N-212A6	Ø91	23	10.6	5812	14990	27.5	3300	62.5	0.809	M2091	HJ12	HC12	Ø30-Ø304
N-212A8	Ø91	23	10.6	5812	14990	27.5	3300	59.5	0.770	M2091	HJ12	HC12	Ø30-Ø304
N-212A11	Ø91	23	10.6	5812	14990	27.5	3300	69.9	0.912	M2091	HJ12	HC12	Ø30-Ø304
N-215A8	Ø117.5	23	10.6	7240	18355	23.5	2500	125	2.255	M2511S	HJ15	HC15	Ø50-Ø381
N-215A11	Ø117.5	23	10.6	7240	18355	23.5	2500	118	2.241	M2511S	HJ15	HC15	Ø50-Ø381
N-215A15	Ø117.5	23	10.6	7240	18355	23.5	2500	138	2.822	M2511S	HJ15	HC15	Ø50-Ø381
N-218A8	Ø117.5	23	10.6	7240	18355	23.5	2000	146	3.961	M2511S	HJ15	HC15	Ø50-Ø450
N-218A11	Ø117.5	23	10.6	7240	18355	23.5	2000	138	3.744	M2511S	HJ15	HC15	Ø50-Ø450
N-218A15	Ø117.5	23	10.6	7240	18355	23.5	2000	191	5.183	M2511S	HJ15	HC15	Ø50-Ø450
N-220A11	Ø180	23	10.6	9177	23861	30.6	1800	215	7.355	ML2816	HJ24-1	HC24-1	Ø120-Ø510
N-220A15	Ø180	23	10.6	9177	23861	30.6	1800	202	6.910	ML2816	HJ24-1	HC24-1	Ø120-Ø510
N-224A11	Ø205	26	12	9177	23861	26.5	1400	332	18.199	ML3320	HJ24-1	HC24-1	Ø150-Ø610
N-224A15	Ø205	26	12	9177	23861	26.5	1400	317	17.376	ML3320	HJ24-1	HC24-1	Ø150-Ø610
N-224A20	Ø205	26	12	9177	23861	26.5	1400	286	15.677	ML3320	HJ24-1	HC24-1	Ø150-Ø610
N-232A11	Ø230	34	18	10197	24472	29.5	1200	530	43	ML3320	HJ24-1	HC24-1	Ø210-Ø800
N-232A15	Ø230	34	18	10197	24472	29.5	1200	515	43	ML3320	HJ24-1	HC24-1	Ø210-Ø800
N-232A20	Ø230	34	18	10197	24472	29.5	1200	485	42	ML3320	HJ24-1	HC24-1	Ø210-Ø800

UNIT : mm

DIM Model	A	B	C (H6)	D	E	F	G	H	J	K	L	M	N max.	O max.	O min.	P max.	P min.	Q	R	S	T	U max.	V	W	X	Y	Reference
N-205A4	135	71	110	14	15	63.513	96	82.55	15.5	3-M10	33	4	26.5	19.75	7.75	16	6	2	10	20	25	M40x1.5	3-M6	44.5	31	62	Fig-1
N-205A5	135	88	110	14	32	82.563	82.55	104.78	14	3-M10	33	4	26.5	19.75	7.75	33	23	2	10	20	25	M40x1.5	6-M10	44.5	31	62	Fig-3
N-206A4	169	96	140	20	20	63.513	104.78	82.55	16	6-M10	45	5	32	22.75	9.25	31	19	2	12	19	31	M55x2	6-M10	60	37	73	Fig-2
N-206A5	169	91	140	20	15	82.563	116	104.78	16	6-M10	45	5	32	22.75	9.25	26	14	2	12	19	31	M55x2	3-M6	60	37	73	Fig-1
N-206A6	169	111	140	20	35	106.375	104.78	133.35	16	6-M10	45	5	32	22.75	9.25	46	34	2	12	19	31	M55x2	6-M12	60	37	73	Fig-3
N-208A5	210	109	170	25	23	82.563	133.35	104.78	14	6-M12	52	5	38.7	29.75	11.75	37.5	21.5	2	14	20.5	35	M60x2	6-M10	66	38	95	Fig-2
N-208A6	210	103	170	25	17	106.375	150	133.35	18	6-M12	52	5	38.7	29.75	11.75	31.5	15.5	2	14	20.5	35	M60x2	3-M6	66	38	95	Fig-1
N-208A8	210	126	170	25	40	139.719	133.35	171.45	24	6-M12	52	5	38.7	29.75	11.75	54.5	38.5	2	14	20.5	35	M60x2	6-M16	66	38	95	Fig-3
N-210A6	254	120	220	30	25	106.375	171.45	133.35	18	6-M16	75	5	51.4	33.75	14.25	33.5	14.5	2	16	25	40	M85x2	6-M12	94	43	110	Fig-2
N-210A8	254	113	220	30	18	139.719	190	171.45	24	6-M16	75	5	51.4	33.75	14.25	26.5	7.5	2	16	25	40	M85x2	3-M8	94	43	110	Fig-1
N-210A11	254	145	220	30	50	196.869	171.45	235	28	6-M16	75	5	51.4	33.75	14.25	58.5	39.5	2	16	25	40	M85x2	6-M20	94	43	110	Fig-3
N-212A6	304	129	220	30	25	106.375	171.45	133.35	18	6-M16	91	6	61.3	45.75	15.75	33	10	2	21	28	50	M100x2	6-M12	108	51	130	Fig-2
N-212A8	304	122	220	30	18	139.719	190	171.45	25	6-M16	91	6	61.3	45.75	15.75	26	3	2	21	28	50	M100x2	3-M8	108	51	130	Fig-1
N-212A11	304	154	220	30	50	196.869	171.45	235	28	6-M16	91	6	61.3	45.75	15.75	58	35	2	21	28	50	M100x2	6-M20	108	51	130	Fig-3
N-215A8	381	160	300	43	33	139.719	235	171.45	24	6-M20	117.5	6	82	45.25	15.25	40	17	5	22	43	62	M130x2	6-M16	139	66	165	Fig-2
N-215A11	381	149	300	43	22	196.869	260	235	28	6-M20	117.5	6	82	45.25	15.25	29	6	5	22	43	62	M130x2	3-M10	139	66	165	Fig-1
N-215A15	381	184	300	43	57	285.775	235	330.2	29	6-M20	117.5	6	82	45.25	15.25	64	41	5	22	43	62	M130x2	6-M24	139	66	165	Fig-3
N-218A8	450	160	300	43	33	139.719	235	171.45	24	6-M20	117.5	6	82	79.75	15.25	40	17	5	22	43	62	M130x2	6-M16	139	66	165	Fig-2
N-218A11	450	149	300	43	22	196.869	260	235	28	6-M20	117.5	6	82	79.75	15.25	29	6	5	22	43	62	M130x2	3-M10	139	66	165	Fig-1
N-218A15	450	184	300	43	57	285.775	235	330.2	29	6-M20	117.5	6	82	79.75	15.25	64	41	5	22	43	62	M130x2	6-M24	139	66	165	Fig-3
N-220A11	510	169	380	60	41	196.869	330.2	235	30	6-M24	180	6	112.5	60.5	24.5	52	29	5	25	38	64	M190x3	6-M20	206	73	180	Fig-2
N-220A15	510	155	380	60	27	285.775	330.2	330.2	33	6-M24	180	6	112.5	60.5	24.5	38	15	5	25	38	64	M190x3	3-M12	206	73	180	Fig-1
N-224A11	610	186	520	60	45	196.869	463.6	235	28	6-M24	205	6	131.9	87.5	24.5	61	35	5	25	38	64	M215x3	6-M20	230	73	180	Fig-2
N-224A15	610	183	520	60	42	285.775	463.6	330.2	32.5	6-M24	205	6	131.9	87.5	24.5	58	32	5	25	38	64	M215x3	6-M24	230	73	180	Fig-2
N-224A20	610	166	520	60	25	412.775	463.6	463.6	35	6-M24	205	6	131.9	87.5	24.5	41	15	5	25	38	64	M215x3	3-M10	230	73	180	Fig-1
N-232A11	800	189	520	60	45	196.869	463.6	235	28	6-M24	230	6	162	153.5	24.5	61	27	5	25	38	64	M250x3	6-M20	262	73	180	Fig-2
N-232A15	800	186	520	60	42	285.775	463.6	330.2	32.5	6-M24	230	6	162	153.5	24.5	58	24	5	25	38	64	M250x3	6-M24	262	73	180	Fig-2
N-232A20	800	169	520	60	25	412.775	463.6	463.6	35	6-M24	230	6	162	153.5	24.5	41	7	5	25	38	64	M250x3	3-M10	262	73	180	Fig-1



Product schematic

N-200

3-jaw through-hole power chuck (adapter excluded)

1. Large through-hole aperture.
2. High-speed rotation.

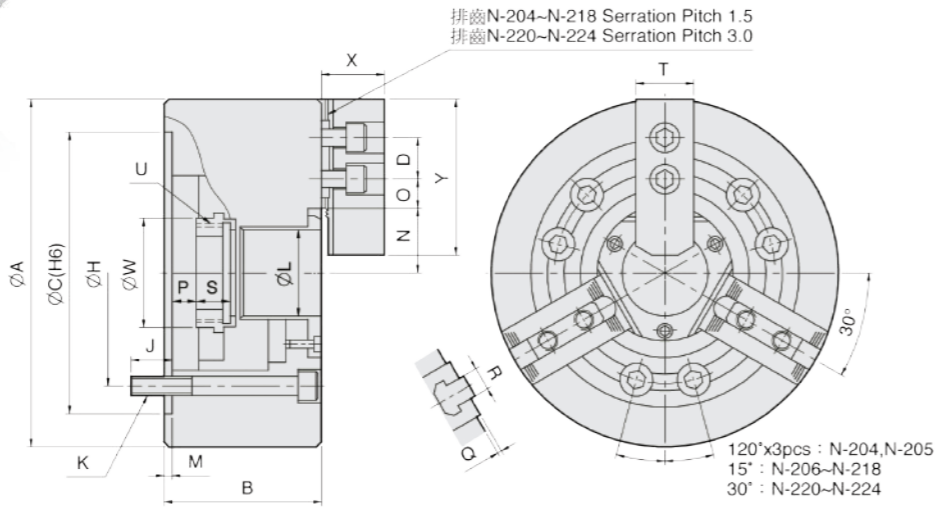

SPEC Model	Through-Hole (mm)	Plunger Stroke (mm)	Jaw Stroke (In Dia.) (mm)	Max. Pull Force (kgf)	Max. Gripping Force (kgf)	Max. Operating Pressure (kgf/cm ²)	Max. Speed (r.p.m.)	Weight (kg)	Moment Of Inertia I (kg·m ²)	Matching Cylinder	Matching Hard Jaw	Matching Soft Jaw	Gripping O.D. Range (mm)
N-204	Ø26	10	5.4	1428	2906	31.6	8000	4	0.007	M0928	HJ05	HC04	Ø4-Ø110
N-205	Ø33	10	5.4	1784	3671	28.5	7000	7	0.018	M1036	HJ05	HC05	Ø6-Ø135
N-206	Ø45	12	5.5	2243	5812	28.5	6000	13.5	0.057	M1246	HJ06	HC06	Ø15-Ø169
N-208	Ø52	16	7.4	3558	9075	26.5	5000	23	0.17	M1552	HJ08	HC08	Ø20-Ø210
N-210	Ø75	19	8.8	4385	11319	27.5	4200	35	0.315	M1875	HJ10	HC10	Ø25-Ø254
N-212	Ø91	23	10.6	5812	14990	27.5	3300	56.5	0.737	M2091	HJ12	HC12	Ø30-Ø304
N-215	Ø117.5	23	10.6	7240	18355	23.5	2500	111	2.27	M2511S	HJ15	HC15	Ø50-Ø381
N-218	Ø117.5	23	10.6	7240	18355	23.5	2000	131	3.55	M2511S	HJ15	HC15	Ø50-Ø450
N-220	Ø180	23	10.6	9177	23861	30.6	1800	190	6.5	ML2816	HJ24-1	HC24-1	Ø120-Ø510
N-224	Ø205	26	12	9177	23861	26.5	1400	270	14.8	ML3320	HJ24-1	HC24-1	Ø150-Ø610
N-232	Ø230	34	18	10197	24472	29.5	1200	470	41	ML3320	HJ24-1	HC24-1	Ø210-Ø800

DIM Model	A	B	C (H6)	D	H	J	K	L	M	N max.	O max.	O min.	P max.	P min.	Q	R	S	T	U max.	W	X	Y
N-204	110	59	85	14	70.6	16	3-M10x60	26	4	23.2	13.75	6.25	3.5	-6.5	2	10	17.5	23	M32x1.5	38	24	49.5
N-205	135	60	110	14	82.55	15	3-M10x60	33	4	26.5	19.75	7.75	1	-9	2	10	20	25	M40x1.5	44.5	31	62
N-206	169	81	140	20	104.78	16	6-M10x80	45	5	32	22.75	9.25	11	-1	2	12	19	31	M55x2	60	37	73
N-208	210	91	170	25	133.35	20	6-M12x90	52	5	38.7	29.75	11.75	14.5	-1.5	2	14	20.5	35	M60x2	66	38	95
N-210	254	100	220	30	171.45	22	6-M16x100	75	5	51.4	33.75	14.25	8.5	-10.5	2	16	25	40	M85x2	94	43	110
N-212	304	110	220	30	171.45	23	6-M16x110	91	6	61.3	45.75	15.75	8	-15	2	21	28	50	M100x2	108	51	130
N-215	381	133	300	43	235	30	6-M20x135	117.5	6	82	45.25	15.25	7	-16	5	22	43	62	M130x2	139	66	165
N-218	450	133	300	43	235	30	6-M20x135	117.5	6	82	79.75	15.25	7	-16	5	22	43	62	M130x2	139	66	165
N-220	510	134	380	60	330.2	35	6-M24x135	180	6	112.5	60.5	24.5	11	-12	5	25	38	64	M190x3	206	73	180
N-224	610	147	520	60	463.6	35	6-M24x150	205	6	131.9	87.5	24.5	16	-10	5	25	38	64	M215x3	230	73	180
N-232	800	150	520	60	463.6	35	6-M24x150	230	6	162	153.5	24.5	16	-18	5	25	38	64	M250x3	262	73	180



Product schematic

NT-200

2-jaw through-hole power chuck (adapter excluded)

1. Model NT2000 chucks are manufactured from high grade alloy steel. All sliding surfaces are hardened and ground for accurate actual running and long service repeatability. Lubrication nipple in each master jaw.
2. Base jaw : 1.5mmx60° serration.
3. Mounting : Adaptor mounting to fit with DIN, ISO, BS, ASA B5.9 type A spindles.

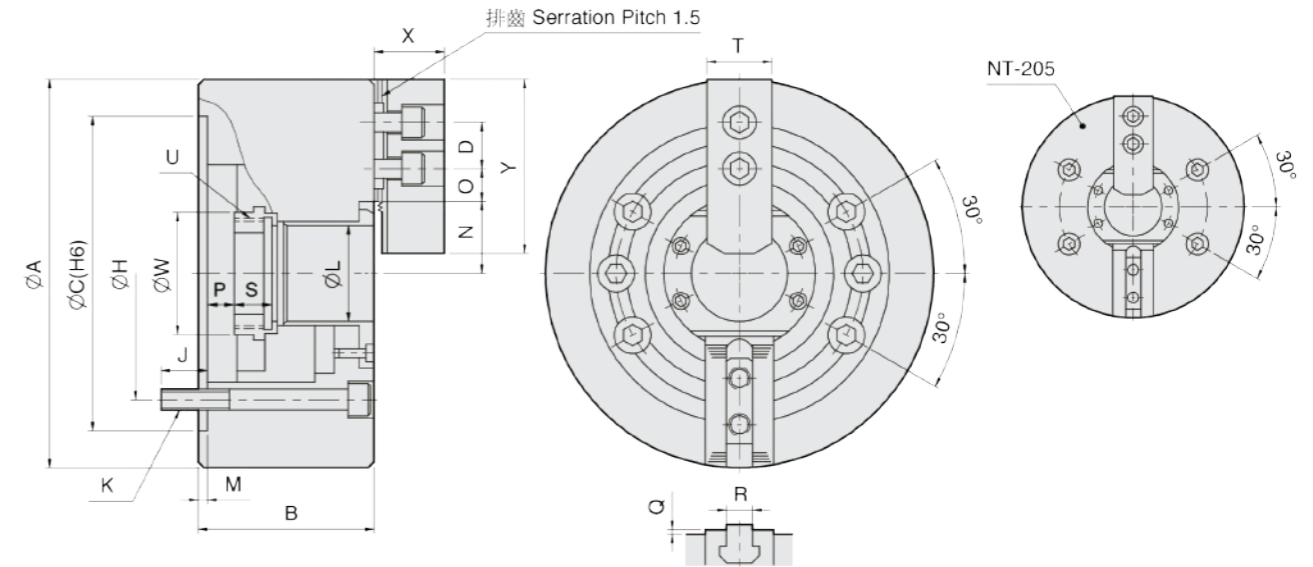

SPEC Model	Through-Hole (mm)	Plunger Stroke (mm)	Jaw Stroke (In Dia.) (mm)	Max. Pull Force (kgf)	Max. Gripping Force (kgf)	Max. Operating Pressure (kgf/cm ²)	Max. Speed (r.p.m.)	Weight (kg)	Moment Of Inertia I (kg·m ²)	Matching Cylinder	Matching Hard Jaw	Matching Soft Jaw	Gripping O.D. Range (mm)
NT-205	Ø33	10	5.4	1189	2447	19.5	7000	6.8	0.017	M1036	HJ05	HC05	Ø6-Ø135
NT-206	Ø45	12	5.5	1495	3875	18.9	6000	12.8	0.054	M1246	HJ06	HC06	Ø15-Ø169
NT-208	Ø52	16	7.4	2366	5975	18.4	5000	22	0.163	M1552	HJ08	HC08	Ø20-Ø210
NT-210	Ø75	19	8.8	2927	7546	18.4	4200	34	0.306	M1875	HJ10	HC10	Ø25-Ø254
NT-212	Ø91	23	10.6	3875	9993	18.4	3300	55	0.717	M2091	HJ12	HC12	Ø30-Ø304
NT-215	Ø117.5	23	10.6	4823	12236	15.3	2500	106	2.17	M2511S	HJ15	HC15	Ø50-Ø381
NT-218	Ø117.5	23	10.6	4823	12236	15.3	2000	122	3.31	M2511S	HJ15	HC15	Ø50-Ø450

DIM Model	A	B	C (H6)	D	H	J	K	L	M	N max.	O max.	O min.	P max.	P min.	Q	R	S	T	U max.	W	X	Y
NT-205	135	60	110	14	82.55	15	4-M10x60	33	4	26.5	19.75	7.75	1	-9	2	10	20	25	M40x1.5	44.5	31	62
NT-206	169	81	140	20	104.78	16	6-M10x80	45	5	32	22.75	9.25	11	-1	2	12	19	31	M55x2	60	37	73
NT-208	210	91	170	25	133.35	20	6-M12x90	52	5	38.7	29.75	11.75	14.5	-1.5	2	14	20.5	35	M60x2	66	38	95
NT-210	254	100	220	30	171.45	22	6-M16x100	75	5	51.4	33.75	14.25	8.5	-10.5	2	16	25	40	M85x2	94	43	110
NT-212	304	110	220	30	171.45	23	6-M16x110	91	6	61.3	45.75	15.75	8	-15	2	21	28	50	M100x2	108	51	130
NT-215	381	133	300	43	235	30	6-M20x135	117.5	6	82	45.25	15.25	7	-16	5	22	43	62	M130x2	139	66	165
NT-218	450	133	300	43	235	30	6-M20x135	117.5	6	82	79.75	15.25	7	-16	5	22	43	62	M130x2	139	66	165

NIT-200

4-jaw through-hole power chuck (adapter excluded)



1. Model NIT2000 chucks are manufactured from high grade alloy steel. All sliding surfaces are hardened and ground for accurate actual running and long service repeatability. Lubrication nipple in each master jaw.
2. Master jaw : 1.5mmx60° serration.
3. Mounting : Adaptor mounting to fit with DIN, ISO, BS, ASA B5.9 type A spindles.

Product schematic

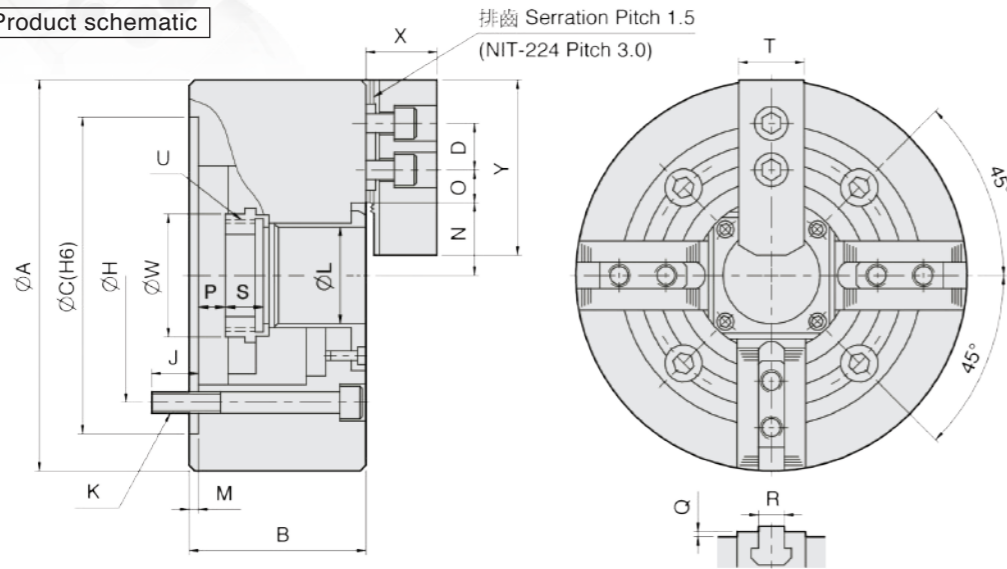

UNIT : mm

SPEC Model	Through-Hole (mm)	Plunger Stroke (mm)	Jaw Stroke (In Dia.) (mm)	Max. Pull Force (kgf)	Max. Gripping Force (kgf)	Max. Operating Pressure (kgf/cm ²)	Max. Speed (r.p.m.)	Weight (kg)	Moment Of Inertia I (kg·m ²)	Matching Cylinder	Matching Hard Jaw	Matching Soft Jaw	Gripping O.D. Range (mm)
NIT-206	Ø45	12	5.5	2243	5812	28.5	4500	13.7	0.058	M1246	HJ06	HC06	Ø15-Ø169
NIT-208	Ø52	16	7.4	3558	9075	26.5	3600	24	0.177	M1552	HJ08	HC08	Ø20-Ø210
NIT-210	Ø75	19	8.8	4385	11319	27.5	3200	36	0.324	M1875	HJ10	HC10	Ø25-Ø254
NIT-212	Ø91	23	10.6	5812	14990	27.5	2700	58.5	0.763	M2091	HJ12	HC12	Ø30-Ø304
NIT-215	Ø117.5	23	10.6	7240	18355	23.5	1900	114	2.331	M2511S	HJ15	HC15	Ø50-Ø381
NIT-218	Ø117.5	23	10.6	7240	18355	23.5	1500	140	3.798	M2511S	HJ15	HC15	Ø50-Ø450
NIT-224	Ø205	26	12	9177	23861	26.5	1000	284	15.2	ML3320	HJ24-1	HC24-1	Ø150-Ø610

DIM Model	A	B	C (H6)	D	H	J	K	L	M	N max.	O max.	O min.	P max.	P min.	Q	R	S	T	U max.	W	X	Y
NIT-206	169	81	140	20	104.78	16	4-M10x80	45	5	32	22.75	9.25	11	-1	2	12	19	31	M55x2	60	37	73
NIT-208	210	91	170	25	133.35	20	4-M12x90	52	5	38.7	29.75	11.75	14.5	-1.5	2	14	20.5	35	M60x2	66	38	95
NIT-210	254	100	220	30	171.45	22	4-M16x100	75	5	51.4	33.75	14.25	8.5	-10.5	2	16	25	40	M85x2	94	43	110
NIT-212	304	110	220	30	171.45	23	4-M16x110	91	6	61.3	45.75	15.75	8	-15	2	21	28	50	M100x2	108	51	130
NIT-215	381	133	300	43	235	30	4-M20x135	117.5	6	82	45.25	15.25	7	-16	5	22	43	62	M130x2	139	66	165
NIT-218	450	133	300	43	235	30	4-M20x135	117.5	6	82	79.75	15.25	7	-16	5	22	43	62	M130x2	139	66	165
NIT-224	610	147	520	60	463.6	35	8-M24x150	205	6	131.9	87.5	24.5	16	-10	5	25	38	64	M215x3	230	73	180

NHT-200

2-jaw and 3-jaw through-hole power chuck (adapter included)



Product schematic

1. Gripping of round or irregular workpiece does not need to change the chuck.
2. The chucks are designed according to ASA B5.9 type A spindle.
3. The chucks are made from high grade alloy steel. All sliding surfaces are hardened and ground to increase running accuracy and longer service life.

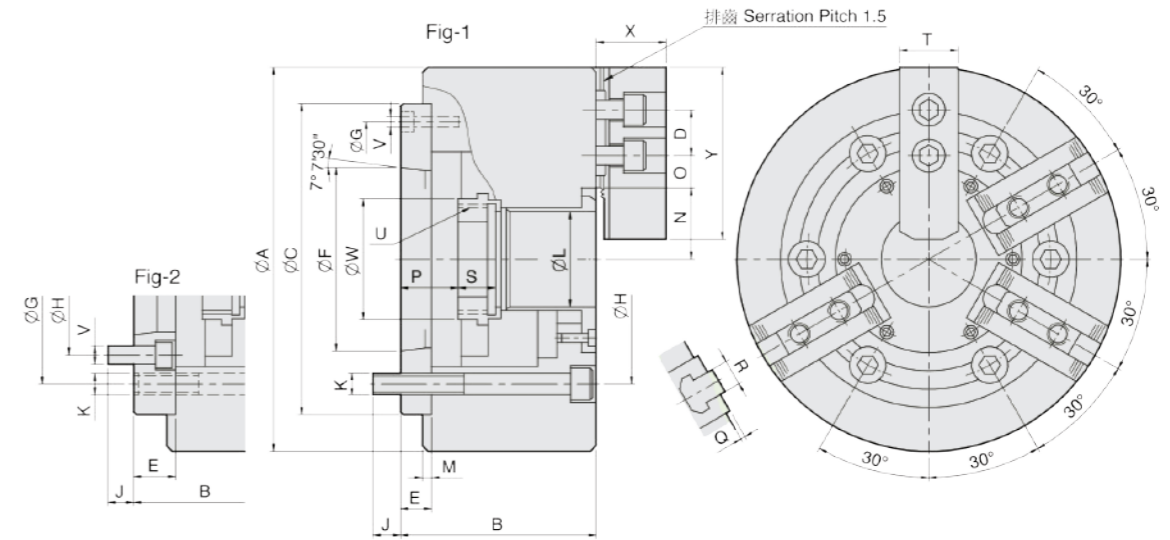

UNIT : mm

SPEC Model	Through-Hole (mm)	Plunger Stroke (mm)	Jaw Stroke (In Dia.) (mm)	Max. Pull Force (kgf) 3 Jaw / 2 Jaw	Max. Gripping Force (kgf) 3 Jaw / 2 Jaw	Max. Operating Pressure (kgf/cm ²) 3 Jaw / 2 Jaw	Max. Speed (r.p.m.)	Weight (kg)	Matching Cylinder	Matching Hard Jaw	Matching Soft Jaw
NHT-208A5	Ø52	16	7.4	2243 / 1495	5812 / 3875	17.2 / 12.1	3500	25.5	M1552	HJ06	HC08-1
NHT-208A6	Ø52	16	7.4	2243 / 1495	5812 / 3875	17.2 / 12.1	3500	24.7	M1552	HJ06	HC08-1

DIM Model	A	B	C (H6)	D	E	F	G	H	J	K	L	M	N max.	O max.	O min.	P max.	P min.	Q	R	S	T	U max.	V	W	X	Y	Reference
NHT-208A5	210	113	170	20	23	82.563	133.35	104.78	14	6xM12	52	5	41.8	34	7.5	37.5	21.5	2	12	20.5	35	M60x2	6xM10	66	37	73	Fig-2
NHT-208A6	210	107	170	20	17	106.375	150	133.35	17	6xM12	52	5	41.8	34	7.5	31.5	15.5	2	12	20.5	35	M60x2	3xM6	66	37	73	Fig-1



Product schematic

NB-200A

3-jaw extra large through-hole power chuck (adapter included)

- More large bore:**
The largest bore in wedge type power operated chucks.
- 20% large bore:**
Approximately 20% higher speed, higher gripping force and larger bore compared with regular chucks.
- Model NB-200A chucks are assembled with adaptor for ASA B5.9 type A spindles.**
- Model NB-200A chucks are manufactured from high grade alloy steel.**
All sliding surfaces are hardened and ground for accurate actual running and long service repeatability.

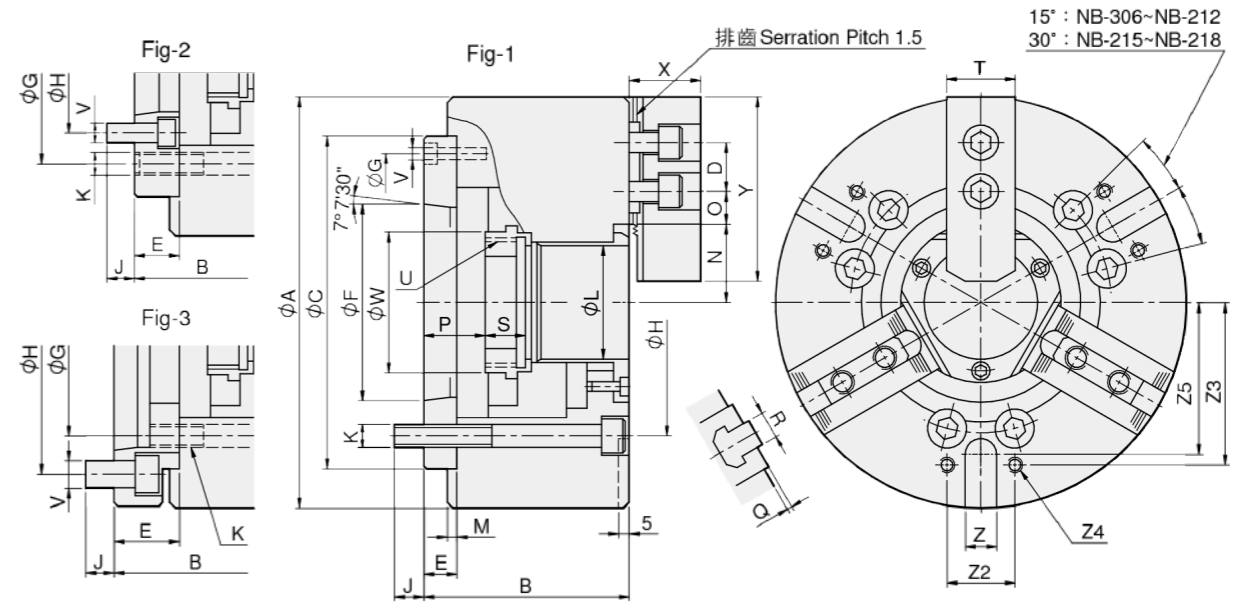

DIM Model	A	B	C (H6)	D	E	F	G	H	J	K	L	M	N max.	O max.	O min.	P max.	P min.
NB-306A5	170	91	140	20	15	82.563	116	104.78	14.5	6-M10	52	5	37	18.25	9.25	26	14
NB-306A6	170	111	140	20	35	106.375	104.78	133.35	16	6-M10	52	5	37	18.25	9.25	46	34
NB-208A6	210	103	170	25	17	106.375	150	133.35	19.5	6-M12	66	5	45.7	23.75	11.75	31.5	15.5
NB-210A8	254	113	220	30	18	139.719	190	171.45	24	6-M16	78	5	53	33.75	14.25	26.5	7.5
NB-310A8	254	113	220	30	18	139.719	190	171.45	24	6-M16	81	5	54	32.25	14.25	26.5	7.5
NB-212A8	315	145	300	30	33	139.719	235	171.45	24	6-M20	122	6	79.5	33.75	11.25	53	30
NB-212A11	315	134	300	30	22	196.869	260	235	28	6-M20	122	6	79.5	33.75	11.25	42	19
NB-215A15	405	154	380	43	27	285.775	330.2	330.2	33	6-M24	142	6	93.5	45.25	15.25	34	11
NB-218A15	457	154	380	43	27	285.775	330.2	330.2	33	6-M24	166.5	6	102	63.25	18.25	34	11

UNIT : mm

SPEC Model	Through-Hole (mm)	Plunger Stroke (mm)	Jaw Stroke (In Dia.) (mm)	Max. Pull Force (kgf)	Max. Gripping Force (kgf)	Max. Operating Pressure (kgf/cm ²)	Max. Speed (r.p.m.)	Weight (kg)	Moment Of Inertia I (kg·m ²)	Matching Cylinder	Matching Hard Jaw	Matching Soft Jaw	Gripping O.D. Range (mm)
NB-306A5	Ø52	12	5.4	2243	5812	18.4	6000	14	0.06	M1552	HJ06	HC06	Ø20-Ø170
NB-306A6	Ø52	12	5.4	2243	5812	18.4	6000	15.6	0.087	M1552	HJ06	HC06	Ø20-Ø170
NB-208A6	Ø66	16	7.4	3558	9075	22.0	5000	24	0.14	M1768	HJ08	HC08	Ø26-Ø210
NB-210A8	Ø78	19	8.8	4385	11319	27.5	4200	37.4	0.4	M1878	HJ10	HC10	Ø36-Ø254
NB-310A8	Ø81	19	8.8	4976	12848	31.5	4500	36.4	0.33	MK1881	HJ10	HC10	Ø37-Ø254
NB-212A8	Ø122	23	10.6	5812	14990	20.5	3200	72.2	1.04	M2511S	HJ12	HC12	Ø59-Ø315
NB-212A11	Ø122	23	10.6	5812	14990	20.5	3200	65	0.95	M2511S	HJ12	HC12	Ø59-Ø315
NB-215A15	Ø142	23	10.6	7240	18355	25.5	2500	130	3.0	ML2816	HJ15	HC15	Ø60-Ø405
NB-218A15	Ø166.5	23	10.6	7240	18355	25.5	2000	161	4.77	ML2816	HJ15	HC15	Ø78-Ø457

DIM Model	Q	R	S	T	U max.	V	W	X	Y	Z (H12)	Z2	Z3	Z4	Z5	Reference
NB-306A5	2	12	20	31	M60x2	3-M6	65	37	73	16	36	65	M8x15	63	Fig-1
NB-306A6	2	12	20	31	M60x2	6-M12	65	37	73	16	36	65	M8x15	63	Fig-3
NB-208A6	2	14	20	35	*M75x2	3-M6	80	38	95	16	45	80	M8x15	78	Fig-1
NB-210A8	2	16	25	40	M87x2	3-M8	94	43	110	16	60	102	M10x20	91	Fig-1
NB-310A8	2	16	25	40	M90x2	3-M8	97	43	110	16	60	102	M10x20	91	Fig-1
NB-212A8	2	21	28	50	M135x2	6-M16	143	51	130	20	60	138	M10x10	123	Fig-2
NB-212A11	2	21	28	50	M135x2	3-M10	143	51	130	20	60	138	M10x10	123	Fig-1
NB-215A15	5	22	43	62	M155x2	3-M12	164	66	165	20	80	160	M12x22	145	Fig-1
NB-218A15	5	22	43	62	M180x3	3-M12	189	66	165	20	100	160	M12x22	145	Fig-1

*Standard thread size M74x2



Product schematic

V

3-jaw wedge type non through-hole power chuck (adapter excluded)

1. High performance :
Similar high performance with N series.
2. Chuck mounting screws :
Metric or UNC socket head cap screws are supplied for installing the chuck to the spindle.

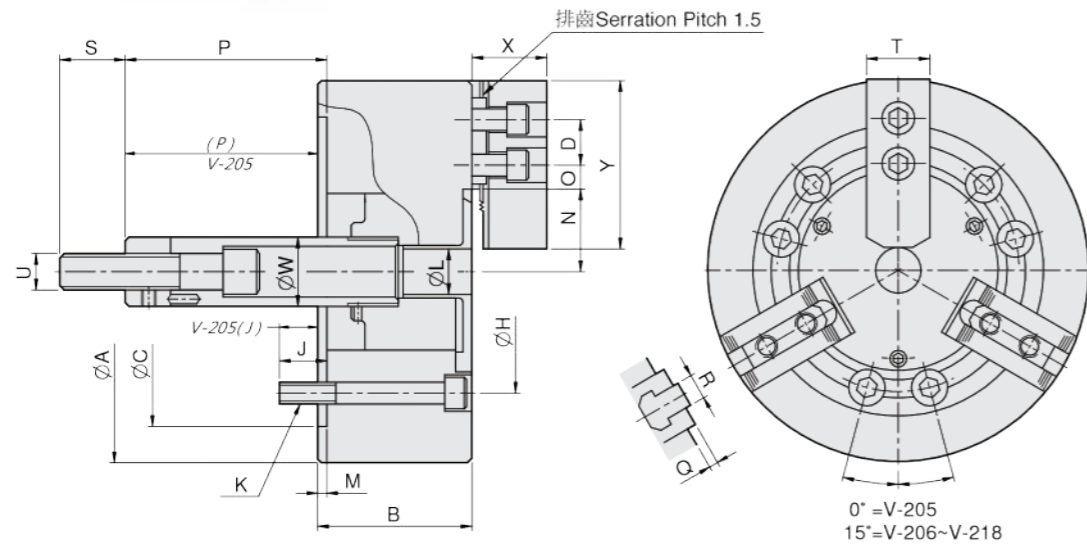

0° = V-205
15° = V-206~V-218

UNIT : mm

SPEC Model	Plunger Stroke (mm)	Jaw Stroke (In Dia.) (mm)	Max. Pull Force (kgf)	Max. Gripping Force (kgf)	Max. Operating Pressure (kgf/cm ²)	Max. Speed (r.p.m.)	Weight (kg)	Moment Of Inertia I (kg · m ²)	Matching Cylinder	Matching Hard Jaw	Matching Soft Jaw	Gripping O.D. Range (mm)
V-205	15	6.4	836	2570	22.4	5500	6.3	0.015	MH80	HJ05	HC05	Ø6-Ø135
V-206	20	9.2	1835	5353	26.5	5200	12.7	0.048	MS105C	HJ06	HC06	Ø18-Ø165
V-208	21	9.7	2549	7648	25.5	4500	23.8	0.137	MS125C	HJ08	HC08	Ø26-Ø210
V-210	25	8.8	2957	11013	28.6	4000	36.4	0.3	MS125C	HJ10	HC10	Ø26-Ø254
V-212	30	10.5	4181	15907	27.5	3300	62.3	0.78	MS150C	HJ12-1	HC12-1	Ø26-Ø304
V-215	35	16	8362	25391	32.6	3000	106	1.94	MS200C	HJ15-1	HC15-1	Ø68-Ø381
V-218	35	16	8362	25391	32.6	2700	122	3.09	MS200C	HJ15-1	HC15-1	Ø98-Ø450

DIM Model	A	B	C	D	H	J	K	L	M	N max.	O max.	O min.	P max.	P min.	Q	R	S	T	U	W	X	Y
V-205	135	55	80	14	100	14	3-M8x60	—	7	30.5	16.75	6.25	9	-6	3	10	35	25	M12x1.75	28	32	62
V-206	165	74	140	20	104.78	14	6-M10x70	21	5	38.7	15.25	7.75	104.6	84.6	4	12	36	31	M16x2.0	34	39	73
V-208	210	85	170	25	133.35	20	6-M12x85	25	5	46.75	22.25	8.75	132	111	5	14	36	35	M20x2.5	38	41	95
V-210	254	89	220	30	171.45	18	6-M16x85	34	5	51.1	30.75	9.75	158	133	5	16	36	40	M20x2.5	45	46	110
V-212	304	106	220	30	171.45	23	6-M16x105	34	6	61	48.75	9.75	163	133	5	18	36	50	M20x2.5	50	54	130
V-215	381	114	300	43	235	29	6-M20x115	—	6	77.5	49.75	21.25	104	69	2	25.5	55	62	M30x3.5	60	63	165
V-218	450	114	300	43	235	29	6-M20x115	—	6	108	49.75	21.25	92	57	2	25.5	55	62	M30x3.5	60	63	165



Product schematic

VT&VIT

2-jaw and 4-jaw wedge type non through-hole power chuck (adapter excluded)

1. Suitable for special applications :
Used to hold special shape work pieces, such as square bar or flanges which is not possible clamping by 3 jaw chuck.
2. Interchangeable with V or VA series.
3. Basic dimensions are the same as V type.
4. High performance as V type.

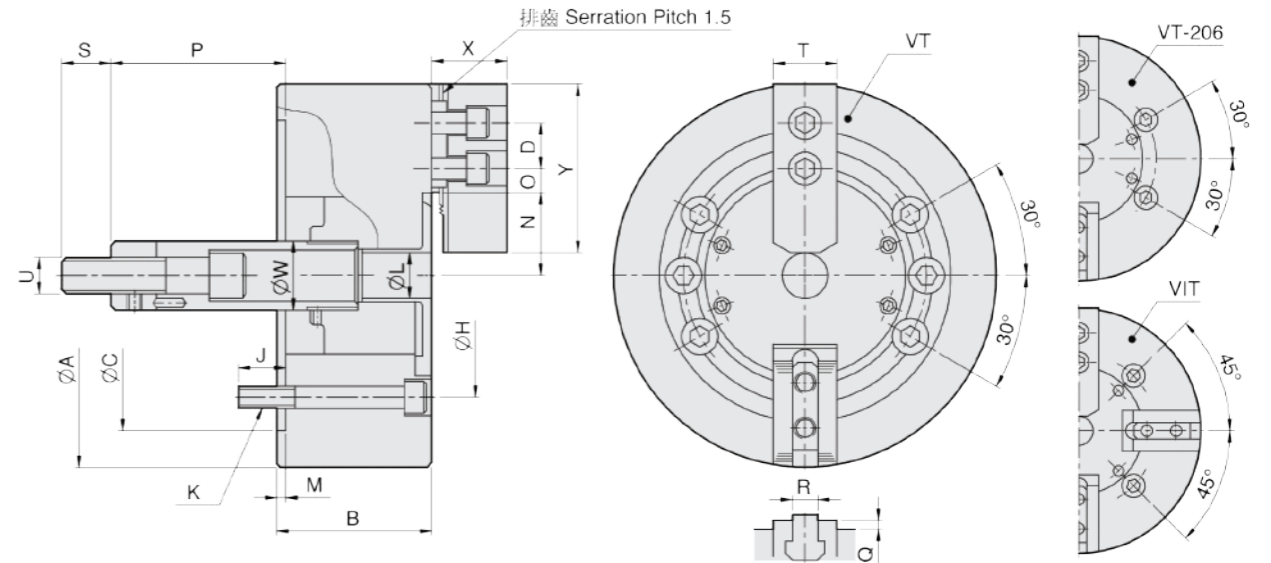

UNIT : mm

SPEC Model	Jaws	Plunger Stroke (mm)	Jaw Stroke (In Dia.) (mm)	Max. Pull Force (kgf)	Max. Gripping Force (kgf)	Max. Operating Pressure (kgf/cm ²)	Max. Speed (r.p.m.)	Weight (kg)	Moment Of Inertia I (kg · m ²)	Matching Cylinder	Matching Hard Jaw	Matching Soft Jaw	Gripping O.D. Range (mm)
VT-206	2	20	9.2	1224	3569	17.3	5200	12.3	0.045	MS105C	HJ06	HC06	Ø18-Ø165
VT-208	2	21	9.7	1683	5098	16.3	4500	23.1	0.13	MS125C	HJ08	HC08	Ø26-Ø210
VT-210	2	25	8.8	1988	7342	19.4	4000	35.1	0.29	MS125C	HJ10	HC10	Ø26-Ø254
VT-212	2	30	10.5	2804	10605	18.4	3300	60.3	0.7	MS150C	HJ12-1	HC12-1	Ø26-Ø304
VIT-212	4	30	10.5	4181	15907	27.5	2800	64.3	0.77	MS150C	HJ12-1	HC12-1	Ø26-Ø304
VT-215	2	35	16	5557	16927	21.7	3000	102.6	1.89	MS200C	HJ15-1	HC15-1	Ø68-Ø381
VIT-218	4	35	16	8362	25391	32.6	2300	127	3.21	MS200C	HJ15-1	HC15-1	Ø98-Ø450

DIM Model	A	B	C	D	H	J	K	L	M	N max.	O max.	O min.	P max.	P min.	Q	R	S	T	U	W	X	Y
VT-206	165	74	140	20	104.78	14	4-M10x70	21	5	38.7	15.25	7.75	104.6	84.6	4	12	36	31	M16x2.0	34	39	73
VT-208	210	85	170	25	133.35	20	6-M12x85	25	5	46.75	22.25	8.75	132	111	5	14	36	35	M20x2.5	38	41	95
VT-210	254	89	220	30	171.45	18	6-M16x85	34	5	51.1	30.75	9.75	158	133	5	16	36	40	M20x2.5	45	46	110
VT-212	304	106	220	30	171.45	23	6-M16x105	34	6	61	48.75	9.75	163	133	5	18	36	50	M20x2.5	50	54	130
VIT-212	304	106	220	30	171.45	23	4-M16x105	34	6	61	48.75	9.75	163	133	5	18	36	50	M20x2.5	50	54	130
VT-215	381	114	300	43	235	29	6-M20x115	—	6	77.5	49.75	21.25	104	69	2	25.5	55	62	M30x3.5	60	63	165
VIT-218	450	114	300	43	235	29	4-M20x115	—	6	108	49.75	21.25	92	57	2	25.5	55	62	M30x3.5	60	63	165



Product schematic

VA

3-jaw wedge type non through-hole power chuck (adapter included)

- Alternative spindle adaptors :
ASA or DIN adaptors can be supplied as requested.

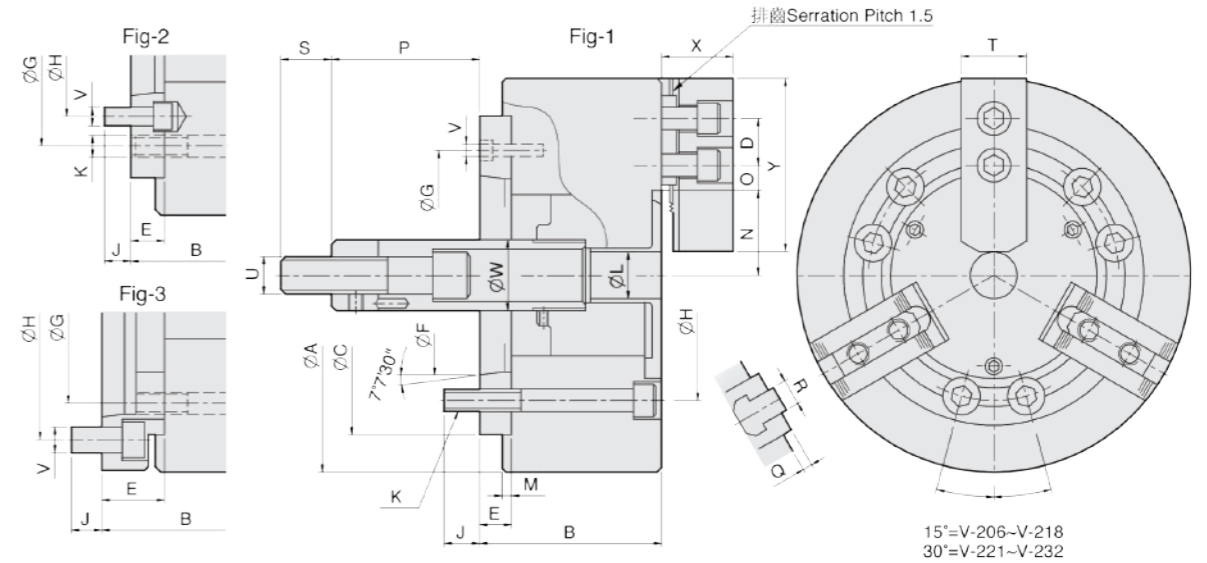

UNIT : mm

SPEC Model	Plunger Stroke (mm)	Jaw Stroke (In Dia.) (mm)	Max. Pull Force (kgf)	Max. Gripping Force (kgf)	Max. Operating Pressure (kgf / cm ²)	Max. Speed (r.p.m.)	Weight (kg)	Moment Of Inertia I (kg · m ²)	Matching Cylinder	Matching Hard Jaw	Matching Soft Jaw	Gripping O.D. Range (mm)
V-206A4	20	9.2	1835	5353	26.5	5200	14.5	0.062	MS105C	HJ06	HC06	Ø18-Ø165
V-206A5	20	9.2	1835	5353	26.5	5200	13.9	0.056	MS105C	HJ06	HC06	Ø18-Ø165
V-206A6	20	9.2	1835	5353	26.5	5200	15.8	0.059	MS105C	HJ06	HC06	Ø18-Ø165
V-208A5	21	9.7	2549	7648	25.5	4500	26.8	0.154	MS125C	HJ08	HC08	Ø26-Ø210
V-208A6	21	9.7	2549	7648	25.5	4500	25.6	0.147	MS125C	HJ08	HC08	Ø26-Ø210
V-208A8	21	9.7	2549	7648	25.5	4500	30	0.172	MS125C	HJ08	HC08	Ø26-Ø210
V-210A6	25	8.8	2957	11013	28.6	4000	41.8	0.35	MS125C	HJ10	HC10	Ø26-Ø254
V-210A8	25	8.8	2957	11013	28.6	4000	39.6	0.33	MS125C	HJ10	HC10	Ø26-Ø254
V-210A11	25	8.8	2957	11013	28.6	4000	50	0.417	MS125C	HJ10	HC10	Ø26-Ø254
V-212A6	30	10.5	4181	15907	27.5	3300	67.6	0.76	MS150C	HJ12-1	HC12-1	Ø26-Ø304
V-212A8	30	10.5	4181	15907	27.5	3300	65.5	0.75	MS150C	HJ12-1	HC12-1	Ø26-Ø304
V-212A11	30	10.5	4181	15907	27.5	3300	75.9	0.888	MS150C	HJ12-1	HC12-1	Ø26-Ø304
V-215A8	35	16	8362	25391	32.6	3000	119	2.12	MS200C	HJ15-1	HC15-1	Ø68-Ø381
V-215A11	35	16	8362	25391	32.6	3000	113	2.05	MS200C	HJ15-1	HC15-1	Ø68-Ø381
V-215A15	35	16	8362	25391	32.6	3000	132	2.56	MS200C	HJ15-1	HC15-1	Ø68-Ø381
V-218A8	35	16	8362	25391	32.6	2700	136	3.28	MS200C	HJ15-1	HC15-1	Ø98-Ø450
V-218A11	35	16	8362	25391	32.6	2700	129	3.20	MS200C	HJ15-1	HC15-1	Ø98-Ø450
V-218A15	35	16	8362	25391	32.6	2700	148	3.71	MS200C	HJ15-1	HC15-1	Ø98-Ø450

UNIT : mm

DIM Model	A	B	C (H6)	D	E	F	G	H	J	K	L	M	N max.	O max.	O min.	P max.	P min.	Q	R	S	T	U	V	W	X	Y	Reference
V-206A4	165	89	140	20	20	63.513	104.78	82.55	16	6-M10	21	5	38.7	15.25	7.75	84.6	64.6	4	12	36	31	M16x2.0	6-M10	34	39	73	Fig2
V-206A5	165	84	140	20	15	82.563	116	104.78	14	6-M10	21	5	38.7	15.25	7.75	89.6	69.6	4	12	36	31	M16x2.0	3-M6	34	39	73	Fig1
V-206A6	165	104	140	20	35	106.375	104.78	133.35	16	6-M10	21	5	38.7	15.25	7.75	69.6	49.6	4	12	36	31	M16x2.0	6-M12	34	39	73	Fig3
V-208A5	210	103	170	25	23	82.563	133.35	104.78	14	6-M12	25	5	46.75	22.25	8.75	109	88	5	14	36	35	M20x2.5	6-M10	38	41	95	Fig2
V-208A6	210	97	170	25	17	106.375	150	133.35	18	6-M12	25	5	46.75	22.25	8.75	115	94	5	14	36	35	M20x2.5	3-M6	38	41	95	Fig1
V-208A8	210	120	170	25	40	139.719	133.35	171.45	24	6-M12	25	5	46.75	22.25	8.75	92	71	5	14	36	35	M20x2.5	6-M16	38	41	95	Fig3
V-210A6	254	109	220	30	25	106.375	171.45	133.35	18	6-M16	34	5	51.1	30.75	9.75	133	108	5	16	36	40	M20x2.5	6-M12	45	46	110	Fig2
V-210A8	254	102	220	30	18	139.719	190	171.45	25	6-M16	34	5	51.1	30.75	9.75	140	115	5	16	36	40	M20x2.5	3-M8	45	46	110	Fig1
V-210A11	254	134	220	30	50	196.869	171.45	235	28	6-M16	34	5	51.1	30.75	9.75	108	83	5	16	36	40	M20x2.5	6-M20	45	46	110	Fig3
V-212A6	304	125	220	30	25	106.375	171.45	133.35	18	6-M16	34	6	61	48.75	9.75	138	108	5	18	36	50	M20x2.5	6-M12	50	54	130	Fig2
V-212A8	304	118	220	30	18	139.719	190	171.45	25	6-M16	34	6	61	48.75	9.75	145	115	5	18	36	50	M20x2.5	3-M8	50	54	130	Fig1
V-212A11	304	150	220	30	50	196.869	171.45	235	28	6-M16	34	6	61	48.75	9.75	113	83	5	18	36	50	M20x2.5	6-M20	50	54	130	Fig3
V-215A8	381	141	300	43	33	139.719	235	171.45	24	6-M20	—	6	77.5	49.75	21.25	71	36	2	25.5	55	62	M30x3.5	6-M16	60	63	165	Fig2
V-215A11	381	130	300	43	22	196.869	260	235	32	6-M20	—	6	77.5	49.75	21.25	82	47	2	25.5	55	62	M30x3.5	3-M10	60	63	165	Fig1
V-215A15	381	165	300	43	57	285.775	235	330.2	29	6-M20	—	6	77.5	49.75	21.25	47	12	2	25.5	55	62	M30x3.5	6-M24	60	63	165	Fig3
V-218A8	450	141	300	43	33	139.719	235	171.45	24	6-M20	—	6	108	49.75	21.25	59	24	2	25.5	55	62	M30x3.5	6-M16	60	63	165	Fig2
V-218A11	450	130	300	43	22	196.869	260	235	32	6-M20	—	6	108	49.75	21.25	70	35	2	25.5	55	62	M30x3.5	3-M10	60	63	165	Fig1
V-218A15	450	165	300	43	57	285.775	235	330.2	29	6-M20	—	6	108	49.75	21.25	35	0	2	25.5	55	62	M30x3.5	6-M24	60	63	165	Fig3

V(40"-79")

Large wedge type non through-hole power chuck (adapter excluded)

1. Chucking operations of very large components external or internal clamping.
2. Suitable for vertical lathe, due to the front protection of slide way.
3. Master jaw with manual radial setting function.



Product schematic

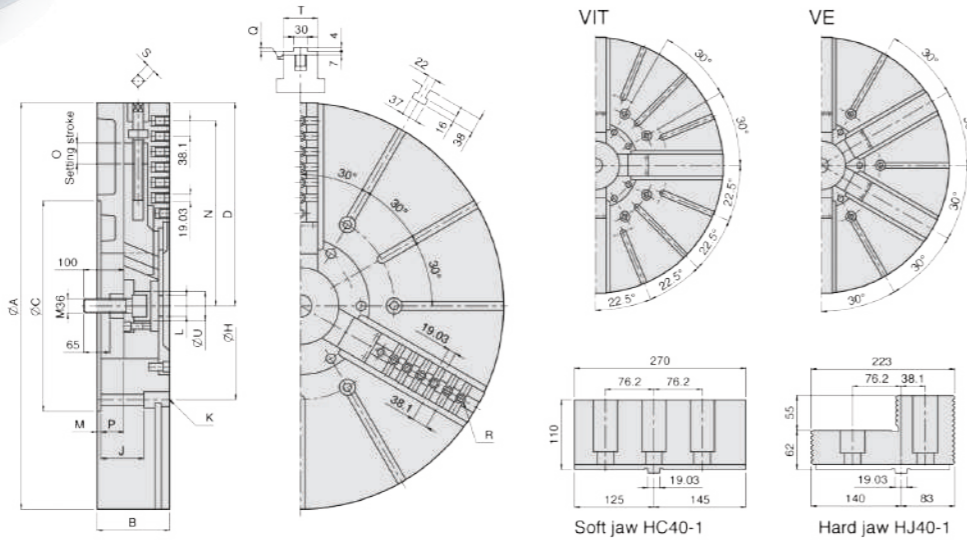

Product schematic

DV/DN

Vertical and vertical horizontal stationary power chuck

1. Suitable for vertical milling and drilling operations.
2. With large through-hole, Vertical / horizontal power chucks do not only clamp the long workpiece but also the horizontal holding.

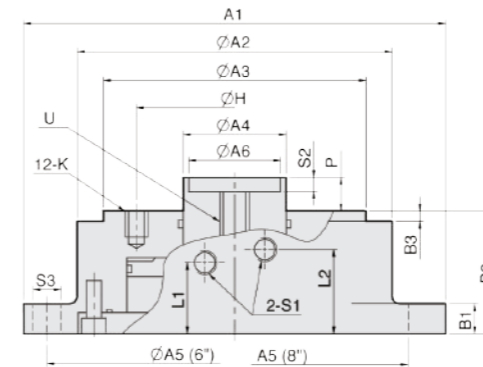
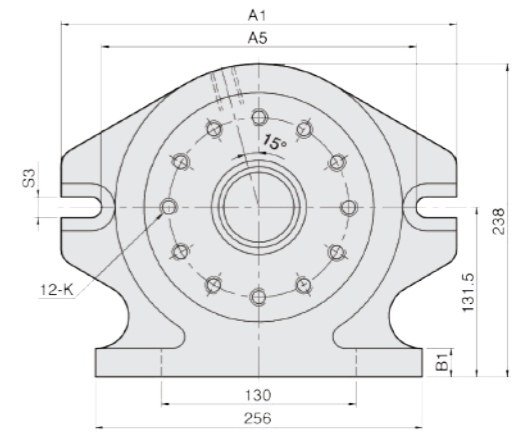

DV Fig-1

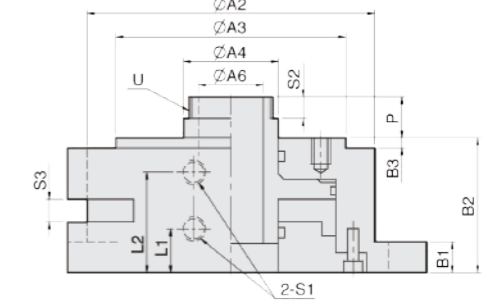

DN Fig-2

UNIT : mm

SPEC Model	Jaws	Plunger Stroke (mm)	Radial Jaw Stroke + (Manual setting) (mm)	Max. Pull Force (kN)	Max. Gripping Force (kN)	Max. Operating Pressure (kgf / cm ²)	Max. Speed (r.p.m.)	Weight (kg)	Moment Of Inertia I (kg · m ²)	Matching Cylinder	Matching Hard Jaw	Matching Soft Jaw	Gripping O.D. Range (mm)
40" V-240	3						630	645	82				
VIT-240	4	57	23 + (30)	180	320	42.8	550	700	89	MS250C	HJ40-1	HC40-1	Ø285-Ø1005
VE-240	6						450	700	89				
50" V-250	3						500	890	168				
VIT-250	4	57	23 + (30)	180	320	42.8	400	940	177	MS250C	HJ40-1	HC40-1	Ø270-Ø1250
VE-250	6						360	971	183				
63" V-263	3						400	1800	548				
VIT-263	4	60	24 + (40)	200	360	46.9	300	1700	518	MS250C	HJ40-1	HC40-1	Ø390-Ø1600
VE-263	6						280	1800	548				
79" VE-279	6	60	24 + (40)	200	360	46.9	230	2850	1350	MS250C	HJ40-1	HC40-1	Ø440-Ø2000

DIM Model	A	B	C	D max.	H	J	K	L	M	N max.	O	P max.	P min.	Q	R	S	T	U	
40" V-240																			
VIT-240	1005	180	520	502	463.6	108	M24	M52x1.5	8	457	30	59	2	4	7-M24	19	85	72	
VE-240																			
50" V-250																			
VIT-250	1250	180	520	623	463.6	108	M24	M52x1.5	8	563	30	59	2	4	10-M24	19	85	72	
VE-250																			
63" V-263																			
VIT-263	1600	220	720	796	647.6	144	M30	M52x1.5	8	738	40	82	22	6	13-M24	22	110	72	
VE-263																			
79" VE-279	2000	238	720	996	647.6	159	M30	M52x1.5	8	914	40	100	40	6	17-M24	22	110	72	

UNIT : mm

SPEC Model	Piston Dia. (mm)	Piston Area (cm ²) Push Side / Pull Side	Max. Draw Bar Force (kgf) Push Side / Pull Side	Piston Stroke (mm)	Max. Operating Pressure (kgf / cm ²)	Weight (kg)	Matching Chuck
DV-6	Ø115	104 / 78.5	1900 / 1400	20	20	12	V-206
DV-8	Ø155	187 / 148.6	3600 / 2800	21	20	21	V-208, V-210, V-212
DN-8	Ø155	148.6 / 148.6	2800 / 2800	17	20	28.5	N-208

DIM Model	A1	A2	A3	A4	A5	A6	B1	B2	B3	H	K	L1	L2	P max.	P min.	S1	S2	S3	U	Reference
DV-6	Ø220	168	140	55	Ø200	49	16	65.5	5.5	104.78	12-M10x15L	38	45	18	-2	PT 1/4"	7.6	2-Ø15	M16xP2.0	Fig-1
DV-8	290	210	170	70	242	58	24	86	5.5	133.35	12-M12x16L	23	65	20	-1	PT 1/4"	5.5	2-16	M16xP2.0	Fig-1
DN-8	293	213	170	70	242	52	24	100	5.5	133.35	12-M12x18L	32.5	74.5	30.4	13.4	PT 1/4"	16	4-17	M60xP2.0	Fig-2



VRA

Non through-hole power chuck for vertical lathe (adapter included)

1. The front protection of slide way.
2. Suitable for vertical lathe.

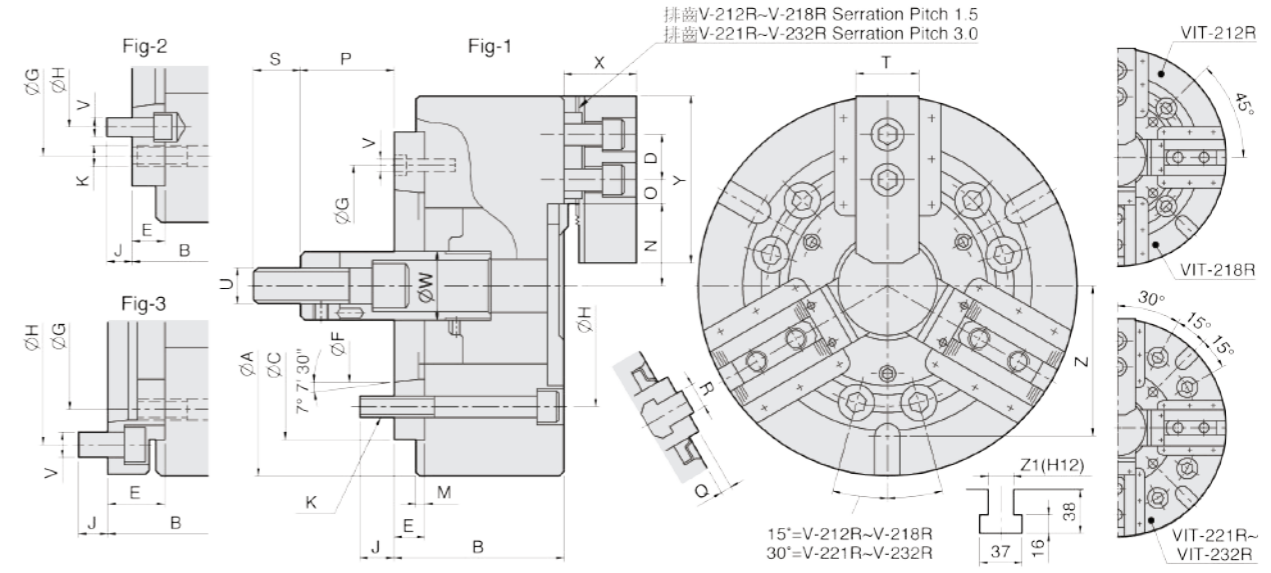

UNIT : mm

SPEC Model	Jaws	Plunger Stroke (mm)	Jaw Stroke (In Dia.) (mm)	Max. Pull Force (kgf)	Max. Gripping Force (kgf)	Max. Operating Pressure (kgf / cm ²)	Max. Speed (r.p.m.)	Weight (kg)	Moment Of Inertia I (kg · m ²)	Matching Cylinder	Matching Hard Jaw	Matching Soft Jaw	Gripping O.D. Range (mm)
V-212RA6	3	30	16	5302	14276	35.7	3000	67.7	0.774	MS150C	HJ12-1	HC12-1	Ø32-Ø304
V-212RA8	3	30	16	5302	14276	35.7	3000	65.6	0.764	MS150C	HJ12-1	HC12-1	Ø32-Ø304
V-212RA11	3	30	16	5302	14276	35.7	3000	74.1	0.902	MS150C	HJ12-1	HC12-1	Ø32-Ø304
V-215RA8	3	35	18.7	9585	25798	35.7	2800	120.4	2.146	MS200C	HJ15-1	HC15-1	Ø68-Ø381
V-215RA11	3	35	18.7	9585	25798	35.7	2800	113.4	2.016	MS200C	HJ15-1	HC15-1	Ø68-Ø381
V-215RA15	3	35	18.7	9585	25798	35.7	2800	133	2.572	MS200C	HJ15-1	HC15-1	Ø68-Ø381
V-218RA8	3	35	18.7	9585	25798	35.7	2300	144.5	3.507	MS200C	HJ15-1	HC15-1	Ø78-Ø450
V-218RA11	3	35	18.7	9585	25798	35.7	2300	137.5	3.43	MS200C	HJ15-1	HC15-1	Ø78-Ø450
V-218RA15	3	35	18.7	9585	25798	35.7	2300	157.5	3.945	MS200C	HJ15-1	HC15-1	Ø78-Ø450
V-221RA8	3	35	16	9075	28450	33.7	1940	198	6.46	MS200C	HJ24-1	HC24-1	Ø65-Ø530
V-221RA11	3	35	16	9075	28450	33.7	1940	190	6.35	MS200C	HJ24-1	HC24-1	Ø65-Ø530
V-221RA15	3	35	16	9075	28450	33.7	1940	184	6.28	MS200C	HJ24-1	HC24-1	Ø65-Ø530
V-224RA8	3	35	16	9075	28450	33.7	1760	240	10.54	MS200C	HJ24-1	HC24-1	Ø152-Ø610
V-224RA11	3	35	16	9075	28450	33.7	1760	233	10.44	MS200C	HJ24-1	HC24-1	Ø152-Ø610
V-224RA15	3	35	16	9075	28450	33.7	1760	227	10.36	MS200C	HJ24-1	HC24-1	Ø152-Ø610
V-232RA11(41)	3	35	18.7	9585	25798	35.7	1060	399	31.6	MS200C	HJ24-1	HC32-1	Ø100-Ø810
V-232RA15	3	35	18.7	9585	25798	35.7	1060	383	30.82	MS200C	HJ24-1	HC32-1	Ø100-Ø810
V-232RA20	3	35	18.7	9585	25798	35.7	1060	419	32.69	MS200C	HJ24-1	HC32-1	Ø100-Ø810
VIT-212RA8	4	30	16	5302	14276	35.7	2500	68	0.792	MS150C	HJ12-1	HC12-1	Ø45-Ø304
VIT-218RA11	4	35	18.7	9585	25798	35.7	2000	141.5	3.522	MS200C	HJ15-1	HC15-1	Ø78-Ø450
VIT-224RA11	4	35	18.7	9075	28450	33.7	1520	255	11.3	MS200C	HJ24-1	HC24-1	Ø152-Ø610
VIT-224RA15	4	35	18.7	9075	28450	33.7	1520	240	11.02	MS200C	HJ24-1	HC24-1	Ø152-Ø610
VIT-232RA11	4	35	18.7	9585	25798	35.7	920	414	32.68	MS200C	HJ24-1	HC32-1	Ø100-Ø810
VIT-232RA15	4	35	18.7	9585	25798	35.7	920	399	32.4	MS200C	HJ24-1	HC32-1	Ø100-Ø810

UNIT : mm

DIM Model	A	B	C (H6)	D	E	F	G	H	J	K	M	N max.	O max.	O min.	P max.	Q min.	R	S	T	U	V	W	X	Y	Z	Z1	Reference	
V-212RA6	304	125	220	30	25	106.375	171.45	133.35	18	6-M16	6	64	45.75	12.75	138	108	5.5	18	36	50	M20x2.5	6-M12	50	54.5	130	—	—	Fig2
V-212RA8	304	118	220	30	18	139.719	190	171.45	24	6-M16	6	64	45.75	12.75	145	115	5.5	18	36	50	M20x2.5	3-M8	50	54.5	130	—	—	Fig1
V-212RA11	304	150	220	30	50	196.869	171.45	235	28	6-M16	6	64	45.75	12.75	113	83	5.5	18	36	50	M20x2.5	6-M20	50	54.5	130	—	—	Fig3
V-215RA8	381	141	300	43	33	139.719	235	171.45	24	6-M20	6	78	49.75	24.25	71	36	5.5	25.5	55	62	M30x3.5	6-M16	60	66.5	165	—	—	Fig2
V-215RA11	381	130	300	43	22	196.869	260	235	32	6-M20	6	78	49.75	24.25	82	47	5.5	25.5	55	62	M30x3.5	3-M10	60	66.5	165	—	—	Fig1
V-215RA15	381	165	300	43	57	285.775	235	330.2	29	6-M20	6	78	49.75	24.25	47	12	5.5	25.5	55	62	M30x3.5	6-M24	60	66.5	165	—	—	Fig3
V-218RA8	450	141	300	43	33	139.719	235	171.45	24	6-M20	6	92	70.75	24.25	59	24	5.5	25.5	55	62	M30x3.5	6-M16	60	66.5	165	158	22	Fig2
V-218RA11	450	130	300	43	22	196.869	260	235	32	6-M20	6	92	70.75	24.25	70	35	5.5	25.5	55	62	M30x3.5	3-M10	60	66.5	165	158	22	Fig1
V-218RA15	450	165	300	43	57	285.775	235	330.2	29	6-M20	6	92	70.75	24.25	35	0	5.5	25.5	55	62	M30x3.5	6-M24	60	66.5	165	158	22	Fig3
V-221RA8	530	154	380	60	33	139.719	330.2	171.45	24	6-M24	6	87	93.5	27.5	64	29	9	25	55	64	M30x3.5	9-M16	60	77	180	155	22	Fig2
V-221RA11	530	148	380	60	27	196.869	330.2	235	30	6-M24	6	87	93.5	27.5	70	35	9	25	55	64	M30x3.5	6-M20	60	77	180	155	22	Fig2
V-221RA15	530	148	380	60	27	285.775	330.2	330.2	33	6-M24	6	87	93.5	27.5	70	35	9	25	55	64	M30x3.5	3-M12	60	77	180	155	22	Fig1
V-224RA8	610	154	380	60	33	139.719	330.2	171.45	24	6-M24	6	126.5	93.5	27.5	64	29	9	25	55	64	M30x3.5	9-M16	60	77	180	165.1	22	Fig2
V-224RA11	610	148	380	60	27	196.869	330.2	235	30	6-M24	6	126.5	93.5	27.5	70	35	9	25	55	64	M30x3.5	6-M20	60	77	180	165.1	22	Fig2
V-224RA15	610	148	380	60	27	285.775	330.2	330.2	33	6-M24	6	126.5	93.5	27.5	70	35	9	25	55	64	M30x3.5	3-M12	60	77	180	165.1	22	Fig1
V-232RA11(41)	810	170	380	80	41	196.869	330.2	235	30	6-M24	6	104.8	196.5	25.5	47	12	5	25	56	74	M30x3.5	6-M20	60	93	210	165.1	22	Fig2
V-232RA15	810	156	380	80	27	285.775	330.2	330.2	33	6-M24	6	104.8	196.5	25.5	47	12	5	25	55	74	M30x3.5	3-M12	60	93	210	165.1	22	Fig1
V-232RA20	810	187	520	80	58	412.775	330.2	463.6	35	6-M24	6	104.8	196.5	25.5	16	-19	5	25	55	74	M30x3.5	6-M24	60	93	210	165.1	22	Fig3
VIT-212RA8	304	118	220	30	18	139.719	190	171.45	24	4-M16	6	64	45.75	12.75	145	115	5.5	18	36	50	M20x2.5	4-M8	50	54.5	130	—	—	Fig1
VIT-218RA11	450	130	300	43	22	196.869	260	235	32	4-M20	6	92	70.75	24.25	70	35	5.5	25.5	55	62	M30x3.5	4-M10	60	66.5	165	158	22	Fig1
VIT-224RA11	610	162	380	60	41	196.869	330.2	235	30	8-M24	6	126.5	93.5	27.5	70	35	9	25	56	64	M30x3.5	6-M20	60	77	180	165.1	22	Fig2
VIT-224RA15	610	148	380	60	27	285.775	330.2	330.2	33	8-M24	6	126.5	93.5	27.5	70	35	9	25	55	64	M30x3.5	4-M12	60	77	180	165.1	22	Fig1
VIT-232RA11	810	170	380	80	41	196.869	330.2	235	30	8-M24	6	104.8	196.5	25.5	47	12	5	25	56	74	M30x3.5	6-M20	60	93	210	200	22	Fig2
VIT-232RA15	810	156	380	80	27	285.775	330.2	330.2	33	8-M24	6	104.8	196.5	25.5	47	12	5	25	55	74	M30x3.5	4-M12	60	93	210	200	22	Fig1



V-300RA

Non through-hole power chuck for vertical lathe (adapter included)

1. Suitable for use in vertical lathes.
2. Special prevent swarf chip and chuck adapter waterproof design.

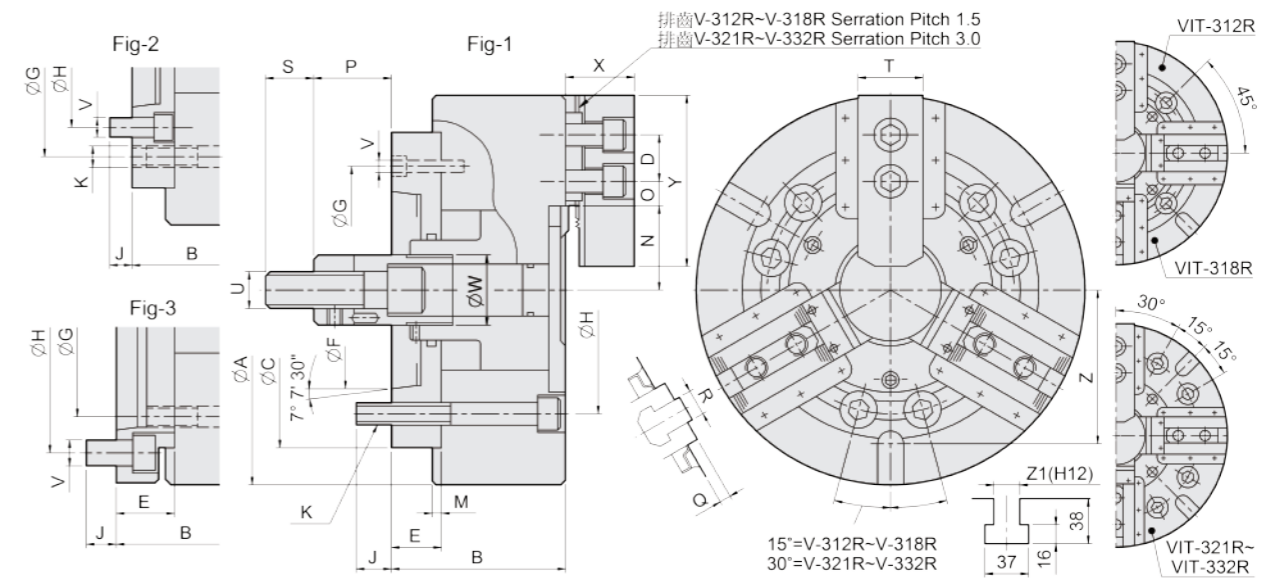

UNIT : mm

SPEC Model	Jaws	Plunger Stroke (mm)	Jaw Stroke (In Dia.) (mm)	Max. Pull Force (kgf)	Max. Gripping Force (kgf)	Max. Operating Pressure (kgf / cm ²)	Max. Speed (r.p.m.)	Weight (kg)	Moment Of Inertia I (kg · m ²)	Matching Cylinder	Matching Hard Jaw	Matching Soft Jaw	Gripping O.D. Range (mm)
V-312RA8	3	30	16	5302	14276	35.7	3000	71	0.773	MS150C	HJ12-1	HC12-1	Ø32-Ø304
V-315RA8	3	35	18.7	9585	25798	35.7	2800	131	2.24	MS200C	HJ15-1	HC15-1	Ø68-Ø381
V-315RA11	3	35	18.7	9585	25798	35.7	2800	128	2.23	MS200C	HJ15-1	HC15-1	Ø68-Ø381
V-315RA15	3	35	18.7	9585	25798	35.7	2800	140	2.64	MS200C	HJ15-1	HC15-1	Ø68-Ø381
V-318RA8	3	35	18.7	9585	25798	35.7	2300	157	3.68	MS200C	HJ15-1	HC15-1	Ø78-Ø450
V-318RA11	3	35	18.7	9585	25798	35.7	2300	155	3.66	MS200C	HJ15-1	HC15-1	Ø78-Ø450
V-318RA15	3	35	18.7	9585	25798	35.7	2300	167	4.07	MS200C	HJ15-1	HC15-1	Ø78-Ø450
V-321RA11	3	35	16	9075	28450	33.7	1940	212	6.73	MS200C	HJ24-1	HC24-1	Ø65-Ø530
V-321RA15	3	35	16	9075	28450	33.7	1940	210	6.75	MS200C	HJ24-1	HC24-1	Ø65-Ø530
V-324RA11	3	35	16	9075	28450	33.7	1760	257	10.83	MS200C	HJ24-1	HC24-1	Ø152-Ø610
V-324RA15	3	35	16	9075	28450	33.7	1760	255	10.85	MS200C	HJ24-1	HC24-1	Ø152-Ø610
V-332RA11	3	35	18.7	9585	25798	35.7	1060	399	30.17	MS200C	HJ24-1	HC32-1	Ø100-Ø810
V-332RA15	3	35	18.7	9585	25798	35.7	1060	397	30.19	MS200C	HJ24-1	HC32-1	Ø100-Ø810
VIT-312RA8	4	30	16	5302	14276	35.7	2500	78	0.78	MS150C	HJ12-1	HC12-1	Ø45-Ø304
VIT-318RA11	4	35	18.7	9585	25798	35.7	2000	158	3.74	MS200C	HJ15-1	HC15-1	Ø78-Ø450
VIT-324RA11	4	35	18.7	9075	28450	33.7	1520	268	11.47	MS200C	HJ24-1	HC24-1	Ø152-Ø610
VIT-324RA15	4	35	18.7	9075	28450	33.7	1520	267	11.49	MS200C	HJ24-1	HC24-1	Ø152-Ø610
VIT-332RA11	4	35	18.7	9585	25798	35.7	920	427	32.85	MS200C	HJ24-1	HC32-1	Ø100-Ø810
VIT-332RA15	4	35	18.7	9585	25798	35.7	920	425	32.87	MS200C	HJ24-1	HC32-1	Ø100-Ø810

UNIT : mm

DIM Model	A	B	C (H6)	D	E	F	G	H	J	K	M	N	O max.	O min.	P max.	P min.	Q	R	S	T	U	V	W	X	Y	Z	Z1	Reference
V-312RA8	304	138	220	30	38	139.719	190	171.45	24	6-M16	6	64	45.75	12.75	145	115	5.5	18	36	50	M20x2.5	3-M8	50	54.5	130	—	—	Fig1
V-315RA8	381	160	300	43	52	139.719	235	171.45	24	6-M20	6	78	49.75	24.25	82	47	5.5	25.5	55	62	M30x3.5	6-M16	60	66.5	165	—	—	Fig2
V-315RA11	381	160	300	43	52	196.869	260	235	32	6-M20	6	78	49.75	24.25	82	47	5.5	25.5	55	62	M30x3.5	3-M10	60	66.5	165	—	—	Fig1
V-315RA15	381	165	300	43	57	285.775	235	330.2	29	6-M20	6	78	49.75	24.25	77	42	5.5	25.5	55	62	M30x3.5	6-M24	60	66.5	165	—	—	Fig3
V-318RA8	450	160	300	43	52	138.719	235	171.45	24	6-M20	6	92	70.75	24.25	82	47	5.5	25.5	55	62	M30x3.5	6-M16	60	66.5	165	158	22	Fig2
V-318RA11	450	160	300	43	52	196.869	260	235	32	6-M20	6	92	70.75	24.25	82	47	5.5	25.5	55	62	M30x3.5	3-M10	60	66.5	165	158	22	Fig1
V-318RA15	450	165	300	43	57	285.775	235	330.2	29	6-M20	6	92	70.75	24.25	77	42	5.5	25.5	55	62	M30x3.5	6-M24	60	66.5	165	158	22	Fig3
V-321RA11	530	173	380	60	52	196.869	330.2	235	30	6-M24	6	87	93.5	27.5	82	47	9	25	55	64	M30x3.5	6-M20	60	77	180	155	22	Fig2
V-321RA15	530	178	380	60	57	285.775	330.2	330.2	33	6-M24	6	87	93.5	27.5	77	42	9	25	55	64	M30x3.5	3-M12	60	77	180	155	22	Fig1
V-324RA11	610	173	380	60	52	196.869	330.2	235	30	6-M24	6	126.5	93.5	27.5	82	47	9	25	55	64	M30x3.5	6-M20	60	77	180	165.1	22	Fig2
V-324RA15	610	178	380	60	57	285.775	330.2	330.2	33	6-M24	6	126.5	93.5	27.5	77	42	9	25	55	64	M30x3.5	3-M12	60	77	180	165.1	22	Fig1
V-332RA11	810	181	380	80	52	196.869	330.2	235	30	6-M24	6	104.8	196.5	25.5	82	47	5	25	55	74	M30x3.5	6-M20	60	93	210	165.1	22	Fig2
V-332RA15	810	186	380	80	57	285.775	330.2	330.2	33	6-M24	6	104.8	196.5	25.5	77	42	5	25	55	74	M30x3.5	3-M12	60	93	210	165.1	22	Fig1
VIT-312RA8	304	138	220	30	38	139.719	190	171.45	24	4-M16	6	64	45.75	12.75	145	115	5.5	18	36	50	M20x2.5	4-M8	50	54.5	130	—	—	Fig1
VIT-318RA11	450	160	300	43	52	196.869	260	235	32	4-M20	6	92	70.75	24.25	82	47	5.5	25.5	55	62	M30x3.5	4-M10	60	66.5	165	158	22	Fig1
VIT-324RA11	610	173	380	60	52	196.869	330.2	235	30	8-M24	6	126.5	93.5	27.5	82	47	9	25	55	64	M30x3.5	6-M20	60	77	180	165.1	22	Fig2
VIT-324RA15	610	178	380	60	57	285.775	330.2	330.2	33	8-M24	6	126.5	93.5	27.5	77	42	9	25	55	64	M30x3.5	4-M12	60	77	180	165.1	22	Fig1
VIT-332RA11	810	181	380	80	52	196.869	330.2	235	30	8-M24	6	104.8	196.5	25.5	82	47	5	25	55	74	M30x3.5	6-M20	60	93	210	200	22	Fig2
VIT-332RA15	810	186	380	80	57	285.775	330.2	330.2	33	8-M24	6	104.8	196.5	25.5	77	42	5	25	55	74	M30x3.5	4-M12	60	93	210	200	22	Fig1

CR

Collet chuck for cylindrical center mount

1. Collet chucks with bayonet catch are mainly used for chucking bar work on NC / CNC lathes.
2. The bar can be fed in through the chuck.
3. Profiles can also be chucked with the appropriate collets.



Product schematic

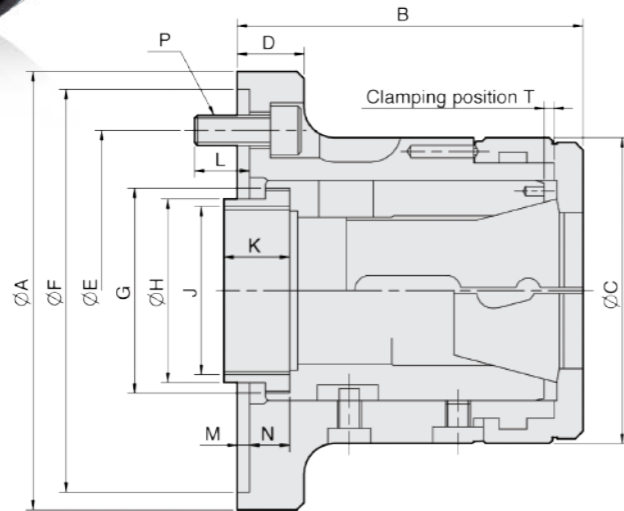

UNIT : mm

SPEC Model	Matching Adapter	Bar Capacity (mm)	Sleeve Stroke (mm)	Max. Push Force kN(kgf)	Max. Gripping Force kN(kgf)	Max. Speed (r.p.m.)	Weight (kg)
CR42-140	140	42	7	25(2549)	55(5608)	6000	6.2
CR52-170	170	52	7	30(3059)	65(6628)	5000	12.5
CR60-170	170	60	7	30(3059)	65(6628)	5000	11.5
CR60-220	220	60	7	30(3059)	65(6628)	5000	15.5
CR80-220	220	80	7	35(3568)	73(7443)	4000	19.5

DIM Model	A (h6)	B	C	D	E	F (H6)	G	H	J max.	K	L	M	N	P	T
CR42-140	155	114	100	23	104.78	140	M66xP1.5	60	M55xP2.0	25	18	6	11.9	3-M10	3.1
CR52-170	185	138	130	30	133.35	170	M90xP1.5	66.7	M60xP2.0	30	18	6	17.9	6-M12	3.1
CR60-170	185	139	130	30	133.35	170	M90xP1.5	80	M74xP2.0	30	18	6	17.9	6-M12	3.1
CR60-220	235	141	130	32	171.45	220	M90xP1.5	80	M74xP2.0	30	20	6	19.9	6-M16	3.1
CR80-220	235	167	156	32	171.45	220	M114xP2.0	99	M90xP2.0	27.5	20	6	23.4	6-M16	6.1

Capacities Chuck	MULTIBORE	SPRING COLLET
NO.	Cat.No. / O / O / □	Cat.No. / O / O / □
CR42	M-673 / 42 / 36 / 30	173E/4728 / 42 / 36 / 30
CR52	- / - / - / -	177E / 52 / 45 / 36
CR60	M-677 / 60 / 52 / 42	185E/4291 / 60 / 52 / 42
CR80	J-660 / 80 / 69 / 56	193E/H-47 / 80 / 69 / 56

Collet Drawings

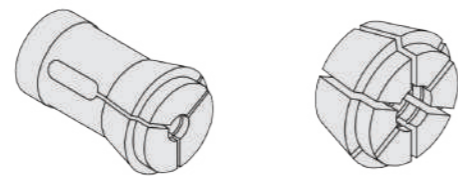

- Spring Collet - - Multi-Bore Collet -

*Uses the collet to DIN6343 specification.

CRA

Collet chuck for short taper mount

1. Collet chucks with bayonet catch are mainly used for chucking bar work on NC / CNC lathes.
2. The bar can be fed in through the chuck.
3. Profiles can also be chucked with the appropriate collets.



Product schematic

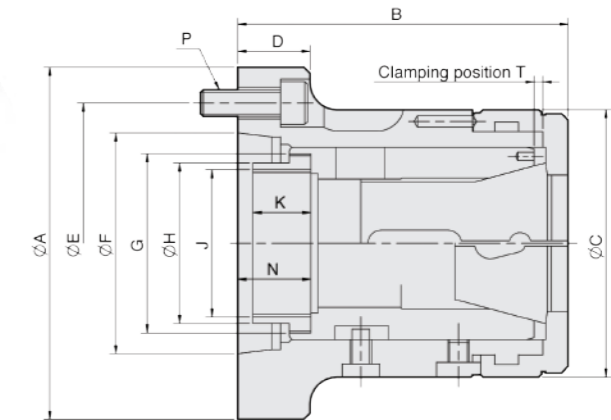

UNIT : mm

SPEC Model	Matching Spindle	Bar Capacity (mm)	Sleeve Stroke (mm)	Max. Push Force kN(kgf)	Max. Gripping Force kN(kgf)	Max. Speed (r.p.m.)	Weight (kg)
CR26A4	A2-4	26	5	20(2039)	44(4486)	7000	4.5
CR30A4	A2-4	30	5	20(2039)	44(4486)	7000	4.1
CR42A5	A2-5	42	7	25(2549)	55(5608)	6000	6.2
CR42A6	A2-6	42	7	25(2549)	55(5608)	6000	8.2
CR52A6	A2-6	52	7	30(3059)	65(6628)	5000	12.2
CR60A6	A2-6	60	7	30(3059)	65(6628)	5000	13
CR80A8	A2-8	80	7	35(3568)	73(7443)	4000	21

DIM Model	A	B	C	D	E	F	G	H	J max.	K	N	P	T
CR26A4	112	103.5	85	30	82.55	63.513	M50xP1.5	45	M40xP1.5	15	21.7	3-M10	2.3
CR30A4	112	103.5	85	30	82.55	63.513	M50xP1.5	45	M40xP1.5	15	21.7	3-M10	2.3
CR42A5	135	127	100	27	104.78	82.563	M66xP1.5	60	M55xP2.0	25	30.9	4-M10	3.1
CR42A6	170	127	100	32	133.35	106.375	M66xP1.5	66	M60xP2.0	22	30.9	4-M12	3.1
CR52A6	170	144	130	27	133.35	106.375	M90xP1.5	66.7	M60xP2.0	30	29.9	4-M12	3.1
CR60A6	170	145	130	27	133.35	106.375	M90xP1.5	80	M74xP2.0	30	29.9	4-M12	3.1
CR80A8	220	170	156	35	171.45	139.719	M114xP2.0	99	M90xP2.0	27.5	32.4	6-M16	6.1

Capacities Chuck	MULTIBORE	SPRING COLLET
NO.	Cat.No. / O / O / □	Cat.No. / O / O / □
CR26	M-667 / 26 / 22 / 18	161E/8744 / 26 / 22 / 18
CR30	M-669 / 30 / 26 / 21	163E/4249 / 30 / 26 / 21
CR42	M-673 / 42 / 36 / 30	173E/4728 / 42 / 36 / 30
CR52	- / - / - / -	177E / 52 / 45 / 36
CR60	M-677 / 60 / 52 / 42	185E/4291 / 60 / 52 / 42
CR80	J-660 / 80 / 69 / 56	193E/H-47 / 80 / 69 / 56

Collet Drawings

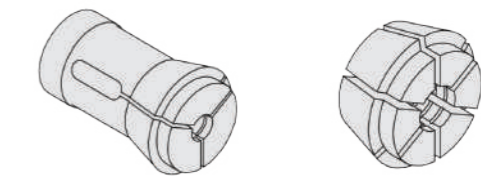

- Spring Collet - - Multi-Bore Collet -

*Uses the collet to DIN6343 specification.



Product schematic

M

High speed through-hole rotary hydraulic cylinder

- 1. Compact and light weight :**
Comparing with the regular product, it is compact (reduced to MAX 95mm) and lighter (weighted MAX 4.5kg). It's more stable to reduce the burden of the machinery at high speed turning.
- 2. The largest bore :** Comparing with the regular product, it has about 20% larger bore diameter for utilizing the capacity of machinery.
- 3. The safety structure :** It can retain the gripping force by check valve.

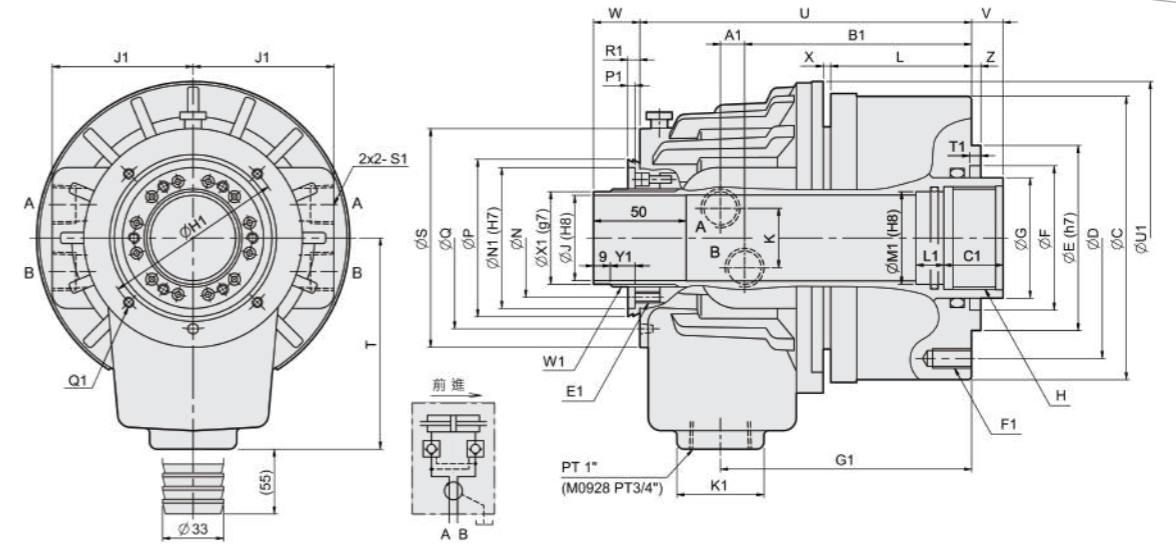

UNIT : mm

DIM Model	A1	B1	C1	E1	F1	G1	H1	J1	K1	L1	M1	N1	P1	Q1	R1	S1	T1	U1	W1	X1	Y1
M0926	9	108	25	8-M6x10	6-M8x15	110	76	58	44	15	30	53	4	4-M4x7	5	PT 1/4"	6	116	M34x1.5	32	15
M0928	9	108	25	8-M6x10	6-M8x15	110	76	58	44	15	34	53	4	4-M4x7	5	PT 1/4"	6	116	M34x1.5	32	15
M1036	11	120.5	25	6-M5x10	6-M10x17	126	88	68	53	15	38	64	4	6-M5x12	5	PT 3/8"	6	136	M44x1.5	42	14
M1038	11	120.5	25	6-M5x10	6-M10x17	126	88	68	53	15	40	64	4	6-M5x12	5	PT 3/8"	6	136	M44x1.5	42	14
M1236	11	126.5	25	6-M6x12	12-M10x20	135	98	76	47	15	38	76	4	4-M5x12	6	PT 1/2"	6	169	M52x1.5	50	14
M1246	11	126.5	30	6-M6x12	12-M10x20	135	98	76	47	15	50	76	4	4-M5x12	6	PT 1/2"	6	169	M52x1.5	50	14
M1546	11	133.5	30	6-M6x12	12-M10x20	145	110	86	47	15	50	85	4	4-M6x12	7	PT 1/2"	6	188	M58x1.5	56	13.5
M1552	11	133.5	30	6-M6x12	12-M10x20	145	110	86	47	15	55	85	4	4-M6x12	7	PT 1/2"	6	188	M58x1.5	56	13.5
M1768	17.5	152.5	35	6-M6x12	12-M10x20	166	155	101	47	15	70	108	4	4-M6x12	7.5	PT 1/2"	6	215	M84x2	81	12.5
M1870	17.5	152.5	35	6-M6x12	12-M10x20	166	155	101	47	15	75	108	4	4-M6x12	7.5	PT 1/2"	6	215	M84x2	81	12.5
M1875	17.5	152.5	35	6-M6x12	12-M10x20	166	155	101	47	15	80	108	4	4-M6x12	7.5	PT 1/2"	6	215	M84x2	81	12.5
M1878	17.5	152.5	35	6-M6x12	12-M10x20	166	155	101	47	20	82	108	4	4-M6x12	7.5	PT 1/2"	6	215	M84x2	81	12.5
M2078	21	166.5	35	6-M6x12	12-M12x24	182	165	110	47	20	84	120	4	4-M6x12	7	PT 1/2"	6	240	M99x2	96	20
M2085	21	166.5	35	6-M6x12	12-M12x24	182	165	110	47	20	89	120	4	4-M6x12	7	PT 1/2"	6	240	M99x2	96	13
M2091	21	166.5	35	6-M6x12	12-M12x24	182	165	110	47	15	95	120	4	4-M6x12	7	PT 1/2"	6	240	M99x2	96	13
M2511S	21	169.5	45	6-M6x12	12-M16x32	192	206	132	55	20	123	160	5	4-M6x12	7	PT 1/2"	6	294	—	134.6	—

UNIT : mm

SPEC Model	Piston Dia. (mm)	Piston Area (cm²) Push Side / Pull Side	Max. Draw Bar Force (kN/kgf) Push Side / Pull Side	Piston Stroke (mm)	Max. Operating Pressure (MPa/kgf/cm²)	Max. Speed (r.p.m)	Moment Of Inertia I (kg · m²)	Weight (kg)	Total Leakage (L/min)
M0926	90	53.2 / 48.3	19.9(2029) / 18(1835)	10	4.0(40.8)	8000	0.006	5.7	3.0
M0928	90	53.2 / 48.3	19.9(2029) / 18(1835)	10	4.0(40.8)	8000	0.006	5.5	3.0
M1036	105	71 / 68.5	26(2651) / 25(2549)	15	4.0(40.8)	8000	0.011	8.6	3.0
M1038	105	71 / 66	26(2651) / 24.5(2498)	15	4.0(40.8)	8000	0.011	8.5	3.0
M1236	125	100 / 89	38(3875) / 33(3365)	15	4.0(40.8)	7000	0.019	13	3.0
M1246	125	100 / 89	38(3875) / 33(3365)	15	4.0(40.8)	7000	0.019	12	3.0
M1546	155	161 / 154	60(6118) / 57.8(5894)	22	4.0(40.8)	6200	0.056	18	3.9
M1552	155	161 / 150	60(6118) / 56(5710)	22	4.0(40.8)	6200	0.052	16.8	3.9
M1768	175	184 / 183	69.3(7067) / 69(7036)	25	4.0(40.8)	4700	0.096	27.5	4.2
M1870	180	198 / 183	74(7546) / 69(7036)	25	4.0(40.8)	4700	0.095	26.5	4.2
M1875	180	198 / 183	74(7546) / 69(7036)	25	4.0(40.8)	4700	0.095	26	4.2
M1878	180	198 / 183	74(7546) / 69(7036)	25	4.0(40.8)	4700	0.095	25.5	4.2
M2078	205	262 / 234	98(9993) / 88(8973)	23	4.0(40.8)	3800	0.15	36.5	4.5
M2085	205	252 / 234	94(9585) / 88(8973)	30	4.0(40.8)	3800	0.15	37.5	4.5
M2091	205	252 / 234	94(9585) / 88(8973)	30	4.0(40.8)	3800	0.15	37	4.5
M2511S	250	348 / 336	124(12644) / 120(12236)	23	4.0(40.8)	2800	0.41	53	7.0

DIM Model	C	D	E	F	G	H	J	K	L	N	P	Q	S	T	U	V max.	V min.	W max.	W min.	X	Z
M0926	120	100	80	65	44	M34x1.5	26	25	63	44	59	76	90	105	151	14	4	35	25	3	5
M0928	120	100	80	65	44	M38x1.5	28	25	63	44	59	76	90	105	151	14	4	35	25	3	5
M1036	136	115	100	65	48	M42x1.5	36	32	71	55	73	88	104	115	174.5	15	0	39	24	2.5	5
M1038	136	115	100	65	50	M44x1.5	38	32	71	55	73	88	104	115	174.5	15	0	39	24	2.5	5
M1236	155	130	100	80	65	M42x1.5	36	36	76	64	85	98	118	114	179	15	0	40	25	4	5
M1246	155	130	100	80	65	M55x2	46	36	76	64	85	98	118	114	179	15	0	40	25	4	5
M1546	190	170	130	85	65	M55x2	46	36	84	73	96	114	137	130	190.5	22	0	47.5	25.5	3.5	5
M1552	190	170	130	85	70	M60x2	52	36	84	73	96	114	137	130	190.5	22	0	47.5	25.5	3.5	5
M1768	215	190	160	120	85	M75x2	68	36	95	98	121	140	165	159	225	25	0	50	25	3	5
M1870	215	190	160	120	95	M78x2	70	36	95	98	121	140	165	159	225	25	0	50	25	3	5
M1875	215	190	160	120	95	M85x2	75	36	95	98	121	140	165	159	225	25	0	50	25	3	5
M1878	215	190	160	120	95	M87x2	78	36	95	98	121	140	165	159	225	25	0	50	25	3	5
M2078	240	215	180	140	110	M90x2	78	36	104	108	138	158	182	177	248	23	0	55	32	3	5
M2085	240	215	180	140	110	M93x2	85	36	104	108	138	158	182	177	248	30	0	55	25	3	5
M2091	240	215	180	140	110	M100x2	91	36	104	108	138	158	182	177	248	30	0	55	25	3	5
M2511S	310	275	230	166	140	M130x2	117.5	36	101	148	178	190	232	215	258	24	1	38	15	3	6



Product schematic

MK

Super high speed through-hole compact rotary hydraulic cylinder

1. The compact hydraulic cylinder which is shorten the length about 30% and light weight can reduce the spindle loading while running in high speed.
2. Built-in check valve in safety auto lock and pressure relief valve in case of power failure occurs.
3. New model developed for rear locking installation.

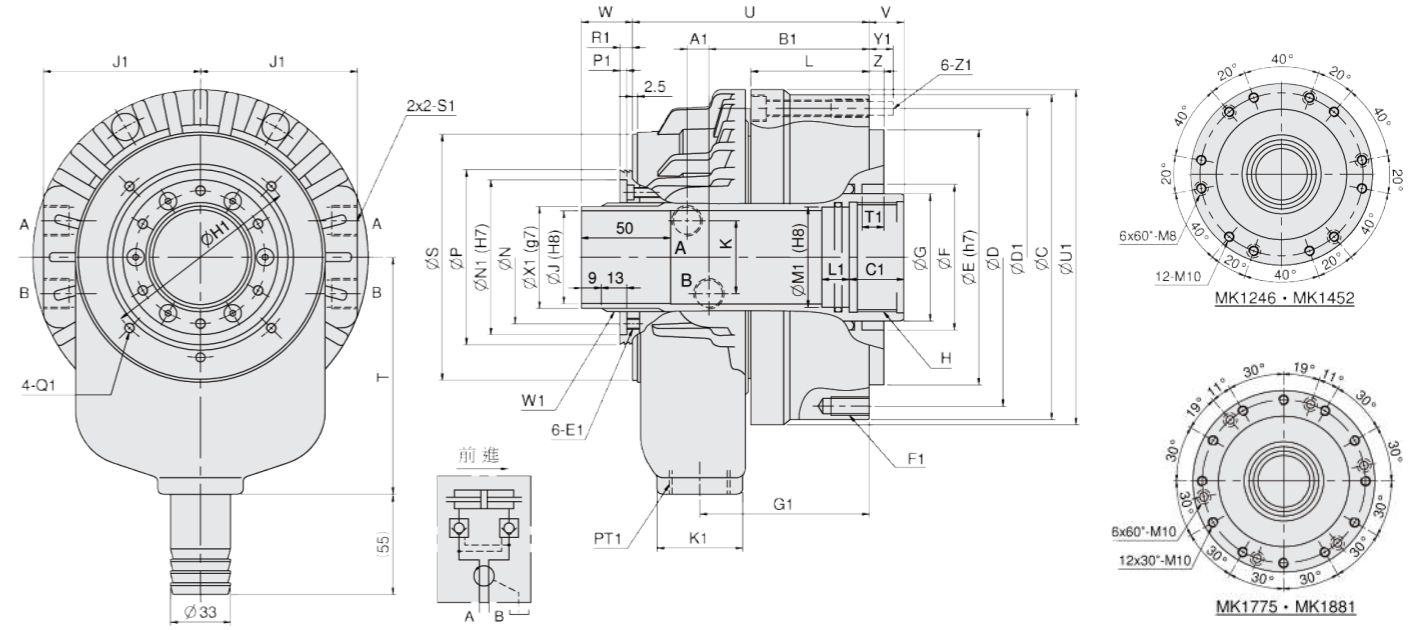

UNIT : mm

DIM Model	A1	B1	C1	E1	F1	G1	H1	J1	K1	L1	M1	N1	P1	Q1	R1	S1	T1	U1	W1	X1	Y1	Z1
MK1246	8.5	79.5	25	M6x10	12-M10x20	84	98	76	47	15	50	76	4	M5x6	9	PT 3/8	12	165	M52x1.5	50	15	M8
MK1246F	8.5	89.5	30	M6x10	6-M10x20	94	98	76	47	15	50	76	4	M5x6	9	PT 3/8	8	165	M52x1.5	50	15	M8
MK1452	9	88	30	M6x12	12-M10x20	93	110	86	47	15	55	85	4	M6x6	16	PT 3/8	12	184	M58x1.5	56	12	M8
MK1452F	9	95	30	M6x12	6-M10x20	100	110	86	47	15	55	85	4	M6x6	16	PT 3/8	8	184	M58x1.5	56	15	M8
MK1768	17.5	99	30	M6x12	12-M10x20	110	155	100	47	15	70	108	4	M6x10	7	PT 1/2	12	216	M84x2.0	81	18	M10
MK1775	17.5	99	30	M6x12	12-M10x20	110	155	100	47	15	80	108	4	M6x10	7	PT 1/2	12	216	M84x2.0	81	18	M10
MK1778	17.5	99	30	M6x12	12-M10x20	110	155	100	47	15	82	108	4	M6x10	7	PT 1/2	12	216	M84x2.0	81	18	M10
MK1881	17	106	35	M6x12	12-M10x20	115	166	105	47	15	85	113	4	M6x10	16.5	PT 1/2	12	226	M89x2.0	86	19	M10

UNIT : mm

SPEC Model	Piston Dia. (mm)	Piston Area (cm²) Push Side / Pull Side	Max. Draw Bar Force (kN/kg) Push Side / Pull Side	Piston Stroke (mm)	Max. Operating Pressure (MPa/kgf / cm²)	Max. Speed (r.p.m.)	Moment Of Inertia I (kg · m²)	Weight (kg)	Total Leakage (L/min)
MK1246	128	102.6 / 91.4	43.6(4466) / 38.9(3967)	16	4.5(45.9)	8000	0.017	8.6	3.1
MK1246F	128	102.6 / 91.4	43.6(4466) / 38.9(3967)	16	4.5(45.9)	8000	0.018	9.2	3.1
MK1452	145	133 / 122.6	56.5(5761) / 52.1(5313)	22	4.5(45.9)	6500	0.028	12	3.9
MK1452F	145	133 / 122.6	56.5(5761) / 52.1(5313)	22	4.5(45.9)	6500	0.029	12.5	3.9
MK1768	170	166 / 152	70.7(7209) / 64.7(6597)	25	4.5(45.9)	5500	0.065	19.4	4.5
MK1775	170	166 / 152	70.7(7209) / 64.7(6597)	25	4.5(45.9)	5500	0.060	17.8	4.5
MK1778	170	166 / 152	70.7(7209) / 64.7(6597)	25	4.5(45.9)	5500	0.059	17.4	4.5
MK1881	180	187 / 171.9	79.5(8107) / 73.1(7454)	25	4.5(45.9)	4800	0.087	24	4.5

DIM Model	C	D	D1	E	F	G	H	J	K	L	N	P	S	T	U	V max.	V min.	W max.	W min.	Z
MK1246	162	147	147	130	75	65	M55x2.0	46	40	58	64	85	116	120	120	13	-3	44	28	8
MK1246F	162	130	147	100	75	65	M55x2.0	46	40	68	64	85	116	120	130	14	-2	44	28	5
MK1452	184	165	165	140	80	70	M60x2.0	52	40	66	73	96	135	130	130	19	-3	53.5	31.5	8
MK1452F	186	170	165	130	80	70	M60x2.0	52	40	73	73	96	135	130	137	21	-1	53.5	31.5	5
MK1768	212	195	195	160	105	95	M75x2.0	68	46	71	98	121	164	160	157	22	-3	50	25	8
MK1775	212	195	195	160	105	95	M85x2.0	75	46	71	98	121	164	160	157	22	-3	50	25	8
MK1778	212	195	195	160	105	95	M87x2.0	78	46	71	98	121	164	160	157	22	-3	50	25	8
MK1881	222	205	205	168	110	100	M90x2.0	81	46	71	103	126	175	175	167	23	-2	58	33	8



Product schematic

CM.B

Hydraulic cylinder coolant collector

1. Can install stroke confirmation device and reclaim oil as well as water.
2. The proximity switches are extra option.



Product schematic

ML-CM.B

Extra large through-hole rotary hydraulic cylinder

1. Matching for large bore power chucks.
2. Special aluminum alloy steel body, light weight for reducing the spindle loading.
3. Within check valves to maintain the thrust force.
4. Extra large bore design, equipped with coolant collector and detective plate.
5. The proximity switches and mounting bolts are extra option.

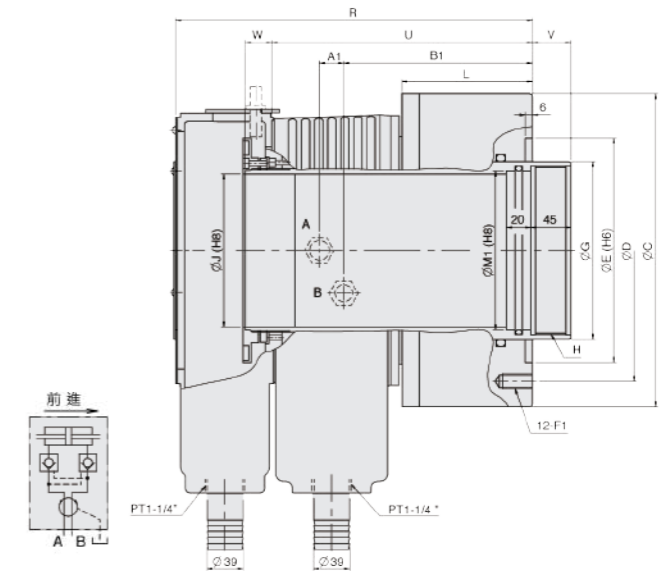
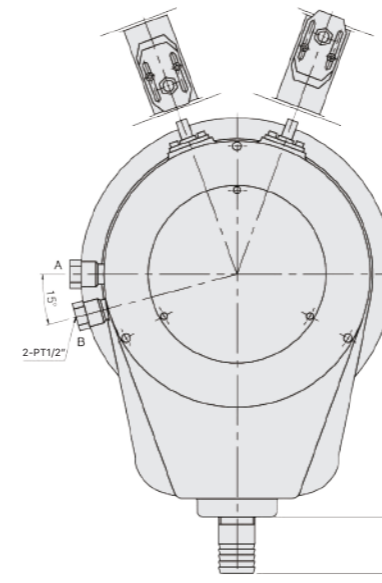
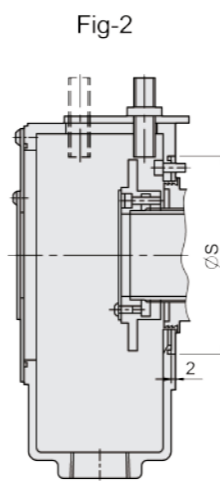
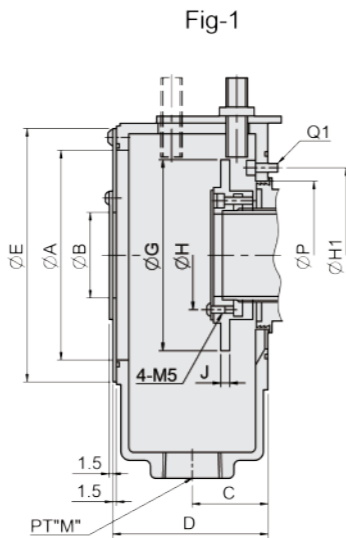
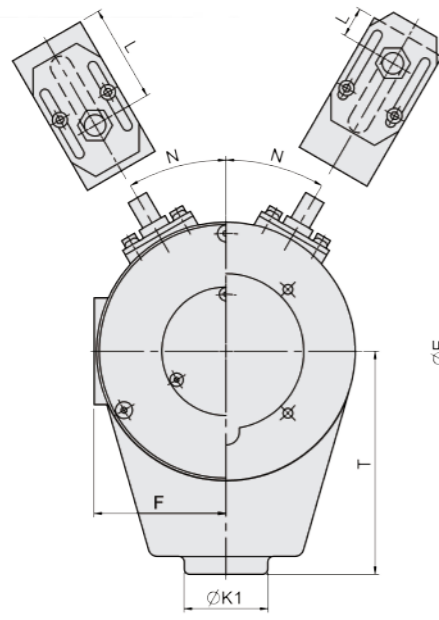

UNIT : mm

DIM Model	A	B	C	D	E	F	G	H	J	L max.	L min.	N	P	S	T	M	H1	K1	Q1	Reference	Matching Cylinder	Weight (kg)
CM09B	82.5	30	35	71.5	106	55.5	77	43	5	47.5	17.5	30	67	90	105	PT 3/4"	76	44	4-M4	Fig2	M0926, M0928	0.85
CM10B1	82.5	40	35	71.5	106	55.5	77	52	5	47.5	17.5	30	75	-	105	PT 3/4"	88	44	6-M5	Fig1	M1036, M1038	1.0
CM12B	117.5	48	42	85.5	142	74	107	61	5	60.5	17.5	30	87	-	130	PT 1"	98	47	4-M5	Fig1	M1236, M1246, MK1246, MM1246B	1.6
CM15B8	117.5	55	42	85.5	142	74	107	67	5	60.5	17.5	30	98	-	130	PT 1"	110	47	4-M6	Fig1	M1546, M1552, MK1452	1.6
CM18B	155	80	42.5	86.5	184	94	147	92	5	58.5	17.5	30	123	-	150	PT 1"	155	47	4-M6	Fig1	M1768, M1875, MK1775	2.0
CM18BK	155	80	42.5	86.5	184	94	147	97	5	60.5	19.5	30	126	175	150	PT 1"	166	47	4-M6	Fig2	MK1881	2.0
CM20B	155	95	42.5	86.5	184	94	147	106	5	60.5	17.5	30	140	-	150	PT 1"	165	47	4-M6	Fig1	M2078, M2085, M2091	2.1
CM25B	200	120	44	89.5	230	117	192	-	12	60	21	27	179	-	180	PT 1"	206	47	4-M6	Fig1	M2511S	2.4
CM28B	254	170	52	103	285	147	240	182	8	74.5	20.5	20	222.6	278	260	PT 1-1/4"	256	85	4-M6	Fig2	ML2814, ML2816	4.2
CM33B	300	208	52	101.5	330	-	285	222	8	74.5	20.5	20	262.6	328	259	PT 1-1/4"	308	70	4-M6	Fig2	ML3320	7.2

UNIT : mm

SPEC Model	Piston Dia. (mm)	Piston Area (cm ²) Push Side / Pull Side	Max. Draw Bar Force (kN/kip) Push Side / Pull Side	Piston Stroke (mm)	Max. Operating Pressure (MPa/kip) / cm ²	Max. Speed (r.p.m.)	Moment Of Inertia I (kg · m ²)	Weight (kg)	Total Leakage L/min
ML2814CM28B	285	394 / 350	116.8(11910) / 106.8(10584)	42	3.3(33.6)	2000	1.08	87	9
ML2816CM28B	285	394 / 350	116.8(11910) / 106.8(10584)	42	3.3(33.6)	2000	0.90	72	9
ML3320CM33B	335	515.7 / 416.9	152.9(15591) / 136.9(13960)	42	3.3(33.6)	1600	1.09	103	10

DIM Model	C	D	E (H6)	G	H	J	L	R	T	U	V max.	V min.	W max.	W min.	A1	B1	F1	M1
ML2814CM28B	335	280	240	190	M158x3.0	145	140	382	260	279	41	-1	67	25	18	202	M16x32L	150
ML2816CM28B	335	280	240	190	M180x3.0	166.5	140	382	260	279	41	-1	67	25	18	202	M16x32L	170
ML3320CM33B	390	320	280	230	M215x3.0	205	147	392	260	292	41	-1	67	25	18	210	M20x32L	210



Product schematic

MM

High speed and compact through-hole rotary hydraulic cylinder

1. Compact hydraulic cylinder design with light weight can reduce the spindle loading while running in high speed.
2. Built-in check valve in safety auto lock and pressure relief valve in case of power failure occur.

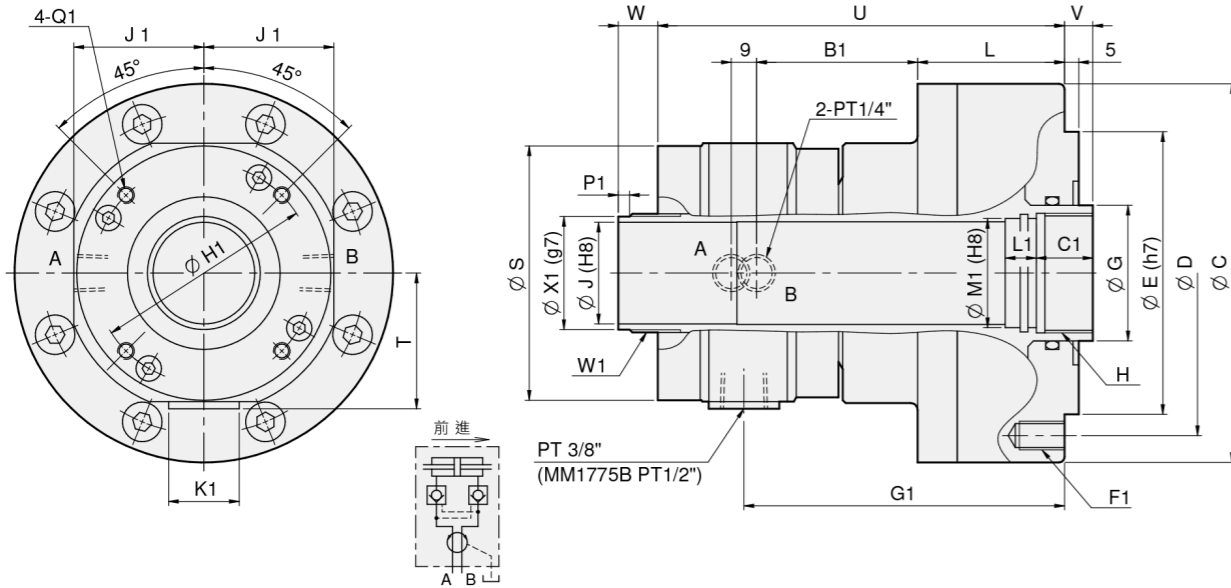

Product schematic

MS

Non through-hole rotary hydraulic cylinder (valve included)

- Built-in safety check valves.

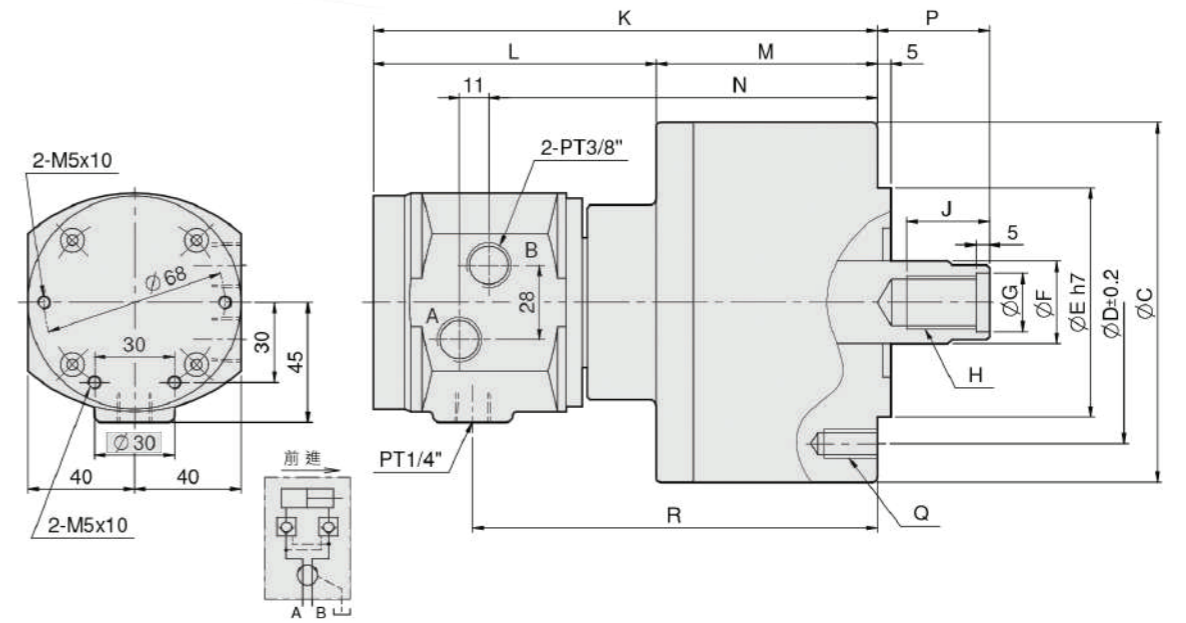

UNIT : mm

SPEC Model	Piston Dia. (mm)	Piston Area (cm²) Push Side / Pull Side	Max. Draw Bar Force (kN(kgf)) Push Side / Pull Side	Piston Stroke (mm)	Max. Operating Pressure (MPa(kgf/cm²))	Max. Speed (r.p.m.)	Moment Of Inertia I (kg·m²)	Weight (kg)	Total Leakage L/min
MM0933B	90	50.3 / 47	19.1(1947) / 17.8(1815)	10	4.0(40.8)	8000	0.012	5.9	0.8
MM1036B	100	64 / 60	23.8(2427) / 22.3(2274)	5	4.0(40.8)	8000	0.013	7	0.8
MM1036B15	100	64 / 60	23.8(2427) / 22.3(2274)	15	4.0(40.8)	8000	0.014	7.4	0.8
MM1246B	125	100 / 89	38(3875) / 33(3365)	15	4.0(40.8)	7000	0.027	11.8	3.0
MM1552B	155	161 / 150	60(6118) / 56(5710)	22	4.0(40.8)	6200	0.046	16	3.0
MM1775B	170	169 / 154.5	63.5(6475) / 58(5914)	25	4.0(40.8)	4200	0.081	22	4.5

UNIT : mm

DIM Model	C	D	E	G	H	J	L	S	T	U	V max.	V min.	W max.	W min.	B1	C1	F1	G1	H1	J1	K1	L1	M1	Q1	W1	P1	X1
MM0933B	120	100	80	46	M40x1.5	33	59	90	48	152	10	0	30	20	58	25	6-M8x15	121.5	76	46	25	10	36	M4x9L	M39xP1.5	5	37
MM1036B	134	115	100	48	M42x1.5	36	52	90	48	144	10	5	17	12	57	20	6-M10x15	113.5	76	46	25	10	38	M4x9L	M42xP1.5	2	40
MM1036B15	134	115	100	48	M42x1.5	36	66	90	48	158	15	0	30	15	57	25	6-M10x15	127.5	76	46	25	15	38	M4x9L	M42xP1.5	3	40
MM1246B	155	130	100	65	M55x2.0	46	76	117	61	179	15	0	40	25	59.5	30	12-M10x20	140	98	59	25	15	50	M5x6L	M52xP1.5	9	50
MM1552B	190	170	130	70	M60x2.0	52	84	135	68	189	22	0	47	25	62.5	30	12-M10x20	150	110	68	25	15	55	M6x6L	M58xP1.5	9	56
MM1775B	209	190	160	95	M85x2.0	75	95	164	82.5	208	25	0	50	25	64	35	12-M10x20	163.5	155	82.5	31	15	80	M6x10L	M84xP2.0	9	81

UNIT : mm

SPEC Model	Piston Dia. (mm)	Piston Area (cm²) Push Side / Pull Side	Max. Draw Bar Force (kN(kgf)) Push Side / Pull Side	Piston Stroke (mm)	Max. Operating Pressure (MPa(kgf/cm²))	Max. Speed (r.p.m.)	Moment Of Inertia I (kg·m²)	Weight (kg)	Total Leakage L/min
MS105	105	86 / 79	32(3263) / 29(2957)	20	4.0(40.8)	6000	0.0125	7.1	0.8
MS125	125	122 / 113	46(4691) / 42(4283)	25	4.0(40.8)	6000	0.0225	10	0.8
MS150	150	176 / 160	66(6730) / 60(6118)	30	4.0(40.8)	5500	0.0475	13.5	0.8
MS200	200	314 / 290	117(11930) / 108(11013)	35	4.0(40.8)	5500	0.0975	22	0.8

UNIT : mm

DIM Model	C	D	E	F	G	H	J	K	L	M	N	P max.	P min.	Q	R
MS105	135	100	80	30	21	M20x2.5	35	197	108	89	152	45	25	6-M10x20	158
MS125	160	130	110	35	25	M24x3.0	44	205	108	97	160	51	26	6-M12x24	166
MS150	190	130	110	45	31	M30x3.5	45	214	108	106	169	56	26	12-M12x24	175
MS200	245	145	120	55	37	M36x4.0	60	228	108	122	183	69	34	12-M16x30	189



MS-C

Non through-hole rotary hydraulic cylinder (valve and switch brackets included)

1. Check valve is included.
2. Check-up safety device is included.
3. The proximity switches are extra option.

Product schematic

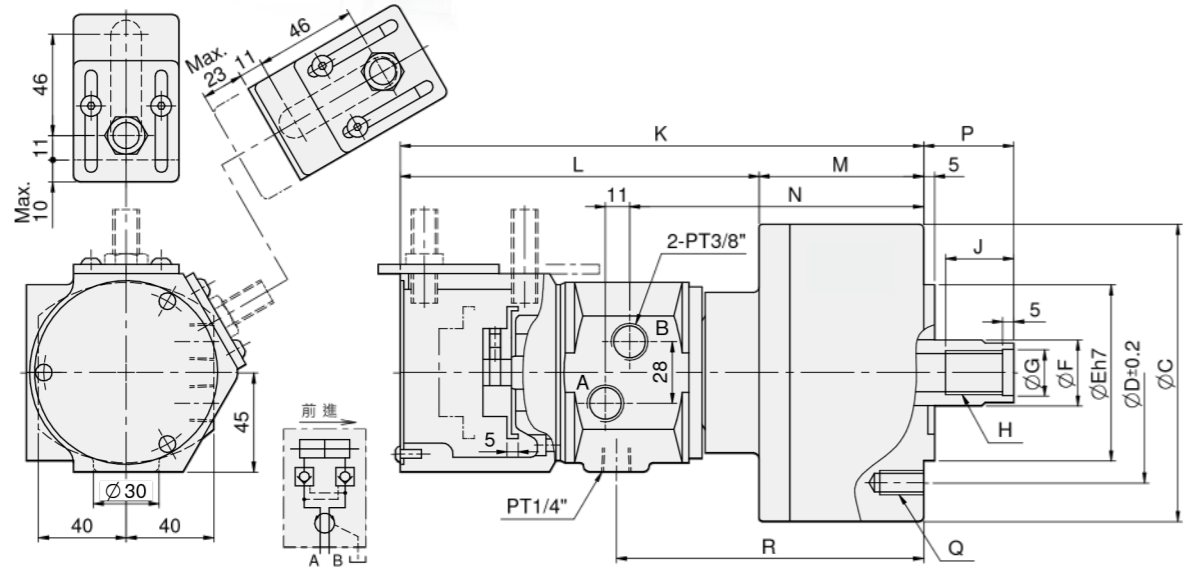

SPEC Model	Piston Dia. (mm)	Piston Area (cm²) Push Side / Pull Side	Max. Draw Bar Force (kN)(kgf) Push Side / Pull Side	Piston Stroke (mm)	Max. Operating Pressure (MPa)(kgf / cm²)	Max. Speed (r.p.m.)	Moment Of Inertia I (kg · m²)	Weight (kg)	Total Leakage L/min
MS105C	105	84 / 79	31 (3161) / 29 (2957)	20	4.0(40.8)	6000	0.0125	7.6	0.8
MS125C	125	120 / 113	45 (4589) / 42 (4283)	25	4.0(40.8)	6000	0.022	10.5	0.8
MS125C35	125	120 / 113	45 (4589) / 42 (4283)	35	4.0(40.8)	6000	0.022	10.5	0.8
MS150C	150	174 / 160	65 (6628) / 60 (6118)	30	4.0(40.8)	5500	0.047	14	0.8
MS200C	200	312 / 290	117 (11930) / 108 (11013)	35	4.0(40.8)	5500	0.097	22.5	0.8

DIM Model	C	D	E	F	G	H	J	K	L	M	N	P max.	P min.	Q	R
MS105C	135	100	80	30	21	M20x2.5	35	257	168	89	152	45	25	6-M10x20	158
MS125C	160	130	110	35	25	M24x3.0	44	265	168	97	160	51	26	6-M12x24	166
MS125C35	160	130	110	35	25	M24x3.0	44	269	168	101	164	57	22	6-M12x24	170
MS150C	190	130	110	45	31	M30x3.5	45	274	168	106	169	56	26	12-M12x24	175
MS200C	245	145	120	55	37	M36x4.0	60	288	166	122	183	69	34	12-M16x30	189

· Draw bar pull force : Pressure 4.0 MPa(40.8kgf / cm²)
 · Total leakage : Pressure 3.0 MPa(30.6kgf / cm²) and oil temperature 50°C
 · Proximity switch : Model BESS 16-329-E4-Y (BALLUFF) DC 12 / 24V 200mA NPN



MS250C/MS300C

Non through-hole rotary hydraulic cylinder (valve and switch brackets included)

1. Through-hole for coolant, oil or air with thread for rotary unit.
2. Mounting from the rear or front side.
3. Built-in safety check valves and bracket for proximity switch. (The proximity switches are extra option.)

Product schematic

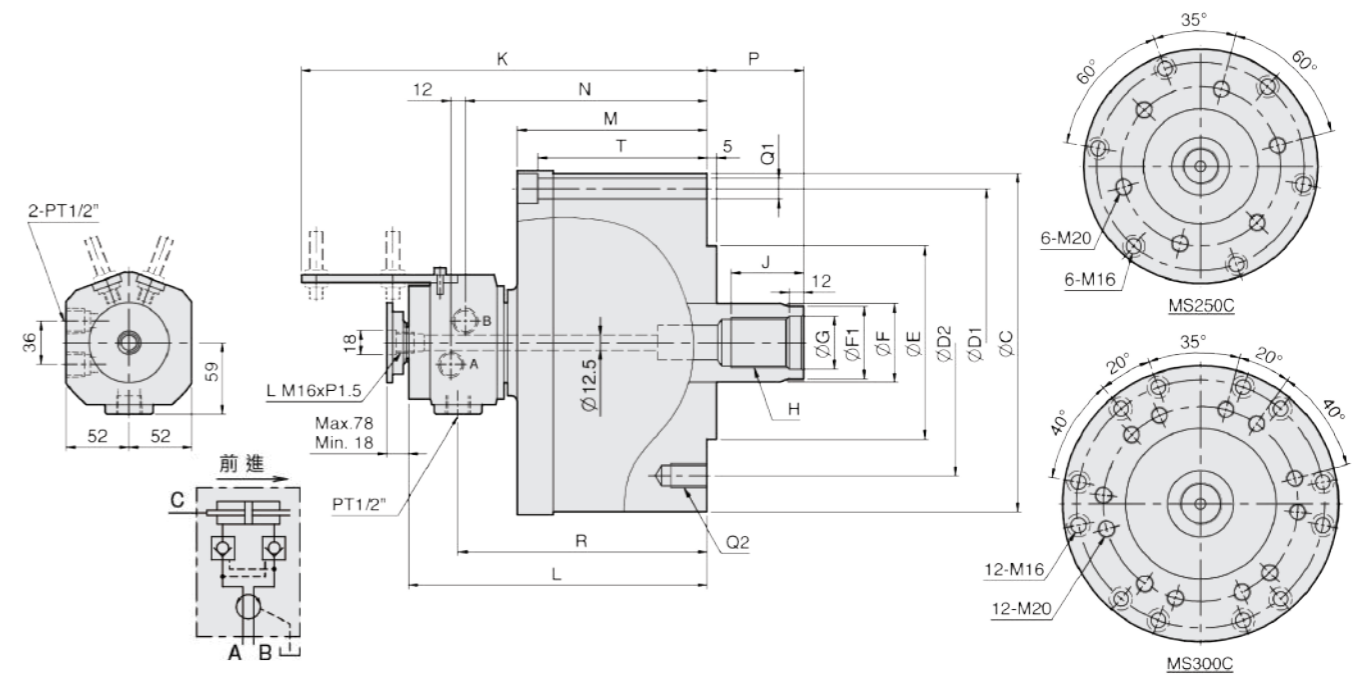

SPEC Model	Piston Dia. (mm)	Piston Area (cm²) Push Side / Pull Side	Max. Draw Bar Force (kN)(kgf) Push Side / Pull Side	Piston Stroke (mm)	Max. Operating Pressure (MPa)(kgf / cm²)	Max. Speed (r.p.m.)	Moment Of Inertia I (kg · m²)	Weight (kg)	Total Leakage L/min
MS250C	250	481.5 / 453.6	227(23147) / 214(21822)	60	4.9(50)	2000	0.85	73	2
MS300C	300	697.5 / 658.6	262(26716) / 247(25186)	60	4.0(40.8)	1500	1.60	106	3

DIM Model	C	D1	D2	E (h7)	F	F1	G	H	J	K	L	M	N	P max.	P min.	Q1	Q2	R	T
MS250C	300	275	220	160	65	62	44	M42x3.0	60	349	260	170	213	85	25	6-Ø17	6-M20x30	219	153
MS300C	355	330	270	210	75	70	50	M48x3.0	70	359	270	182	223	85	25	12-Ø17	12-M20x30	229	165



Product schematic

MR

Short Type Non Through Hole Rotary Hydraulic

1. Light weight design can reduce the spindle loading for vertical lathe application.
2. Built-in check valve and proximity switch brackets.
3. Developed for rear locking installation.

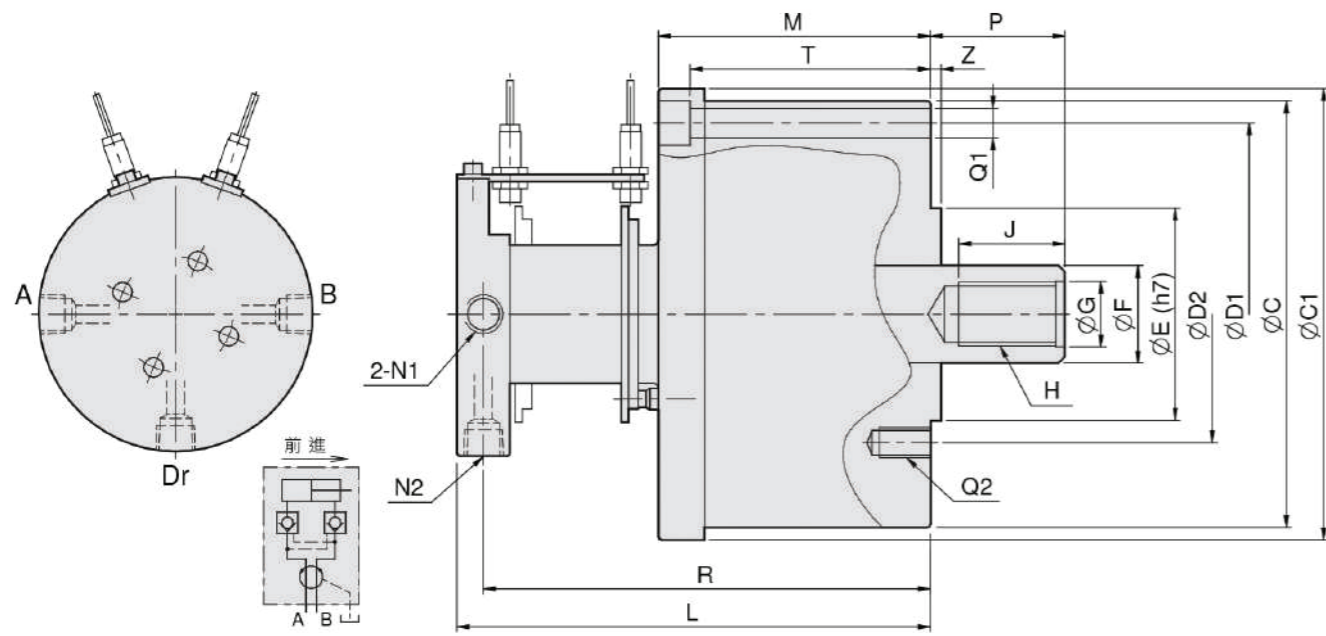

Product schematic

MRA

Super-short type, non through-hole of rotary hydraulic cylinder with gas injection function

1. High-speed and lightweight design, suitable for vertical lathes.
2. Check valve and stroke detection frame are included.
3. Can lock in at back end during installation.
4. Can be equipped with gas injection function.

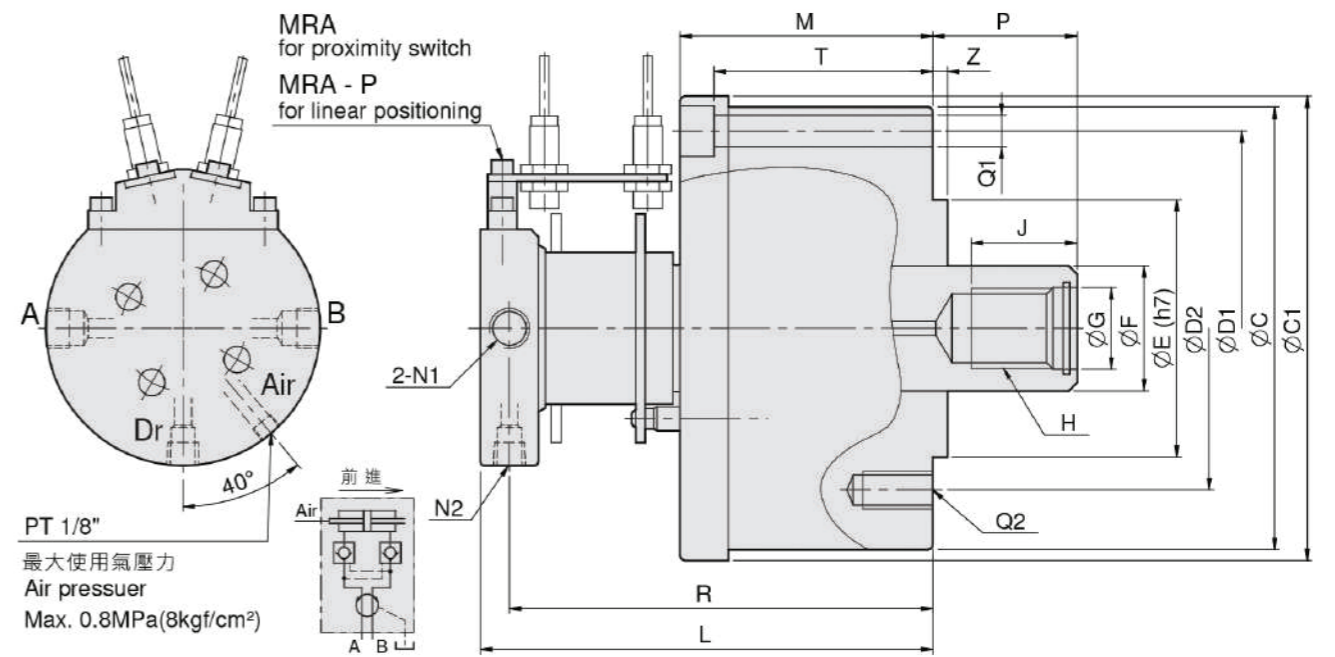

UNIT : mm

SPEC Model	Piston Dia. (mm)	Piston Area (cm²) Push Side / Pull Side	Max. Draw Bar Force kN(kgf) Push Side / Pull Side	Piston Stroke (mm)	Max. Operating Pressure MPa(kgf/cm²)	Max. Speed (r.p.m.)	Moment Of Inertia I (kg·m²)	Weight (kg)	Total Leakage L/min
MR12535	125	117 / 107.5	49(4996) / 45(4588)	35	4.5(45.9)	6000	0.028	9.5	0.8
MR15035	150	171.1 / 156.7	72(7342) / 66(6730)	35	4.5(45.9)	5500	0.043	12.8	0.8
MR20060	200	310 / 286	146(14887) / 134(13664)	60	4.9(50)	5500	0.55	49	2
MR25060	250	481.5 / 453.6	227(23147) / 214(21822)	60	4.9(50)	2000	0.81	72	2

DIM Model	C	C1	D1	D2	E (h7)	F	G	H	J	L	M	N1	N2	P max.	P min.	Q1	Q2	R	T	Z
MR12535	169	171	150	130	110	35	25	M24x3.0	44	174	94	PT 3/8"	PT 1/4"	57	22	6-Ø11	6-M12	162	82	5
MR15035	202	204	180	130	110	45	31	M30x3.5	45	175	95	PT 3/8"	PT 1/4"	61	26	6-Ø13	12-M12	163	82	5
MR20060	250	255	225	145	120	55	37	M36x4.0	60	270	156	PT 1/2"	PT 1/2"	85	25	6-Ø17	6-M16	255	140	6
MR25060	300	305	275	220	160	65	44	M42x3.0	60	280	168	PT 1/2"	PT 1/2"	85	25	6-Ø17	6-M20	265	150	6

UNIT : mm

SPEC Model	Piston Dia. (mm)	Piston Area (cm²) Push Side / Pull Side	Max. Draw Bar Force kN(kgf) Push Side / Pull Side	Piston Stroke (mm)	Max. Operating Pressure MPa(kgf/cm²)	Max. Speed (r.p.m.)	Moment Of Inertia I (kg·m²)	Weight (kg)	Total Leakage L/min
MRA12535	125	116 / 107.5	48.5(4945) / 45(4588)	35	4.5(45.9)	6000	0.028	9.3	0.8
MRA15035	150	170.2 / 156.7	71.6(7301) / 66(6730)	35	4.5(45.9)	5500	0.043	12.8	0.8

DIM Model	C	C1	D1	D2	E (h7)	F	G	H	J	L	M	N1	N2	P max.	P min.	Q1	Q2	R	T	Z
MRA12535	169	171	150	130	110	35	25	M24x3.0	44	177	94	PT3/8"	PT1/4"	57	22	6-Ø11	6-M12	165	82	5
MRA15035	202	204	180	130	110	45	31	M30x3.0	45	178	95	PT3/8"	PT1/4"	61	26	6-Ø13	12-M12	166	82	5

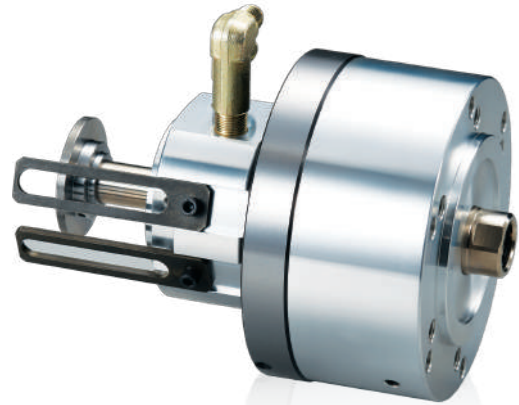

Product schematic

MRR

Short type non through-hole of rotary hydraulic Cylinder (for rotary adaptor)

1. High-speed and lightweight design, suitable for vertical lathes.
2. Check valve and stroke detection frame are included.
3. Can lock in at the back end during installation.
4. Can inject water and gas from the center bore through rotary adaptor.



Product schematic

MH-F

Non through-hole rotary hydraulic cylinder

1. Dense substance, low inertia, light shape: this hydraulic cylinder is made of aluminum alloy, which is light design and can reduce the load of machine main shaft.
2. High speed operation: The balance design of this hydraulic cylinder is with light and dense substance, which can maintain the outside shape evenly and stably while operating at high speed.
3. Long life: due to the high quality of oil seal and high precision on surface roughness of parts ensures the long life of this hydraulic cylinder.

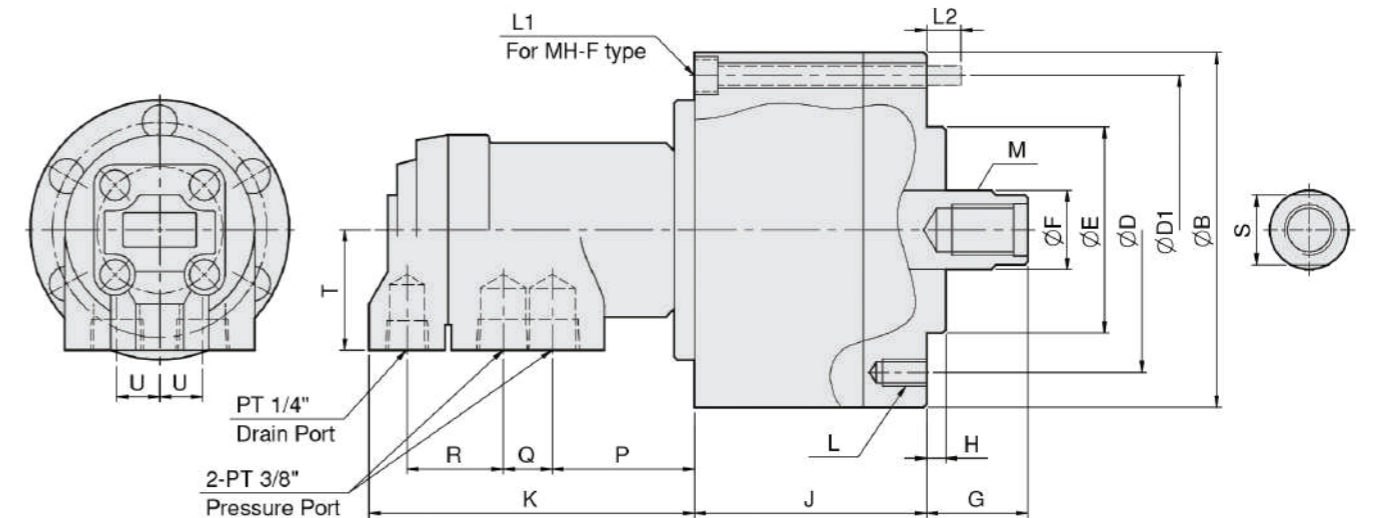
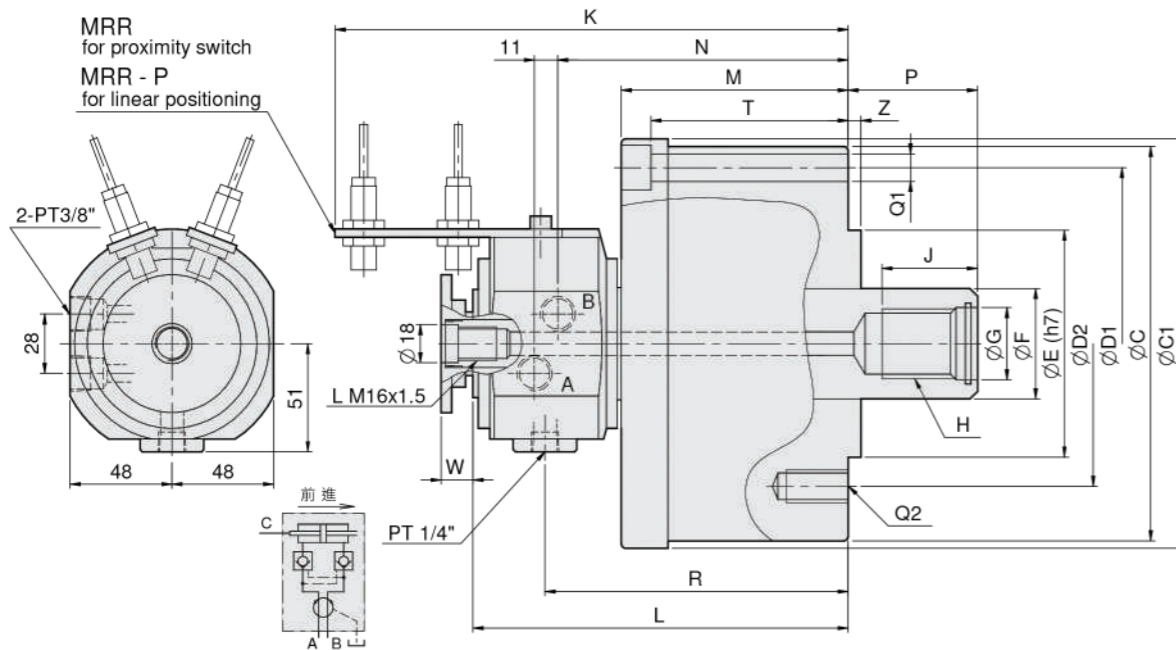

UNIT : mm

SPEC Model	Piston Dia. (mm)	Piston Area (cm²) Push Side / Pull Side	Max. Draw Bar Force (kN(kgf)) Push Side / Pull Side	Piston Stroke (mm)	Max. Operating Pressure (MPa(kgf/cm²))	Max. Speed (r.p.m.)	Moment Of Inertia I (kg·m²)	Weight (kg)	Total Leakage (L/min)
MRR12535	125	113 / 107.5	47.3(4823) / 45(4588)	35	4.5(45.9)	6000	0.027	9.8	0.8

DIM Model	C	C1	D1	D2	E (h7)	F	G	H	J	K	L	M	N	P max.	P min.	Q1	Q2	R	T	W max.	W min.	Z
MRR12535	169	171	150	130	110	35	25	M24x3.0	44	229	164	94	124	57	22	6-Ø11	6-M12	130	82	50	15	5

UNIT : mm

SPEC Model	Piston Dia. (mm)	Piston Area (cm²) Push Side / Pull Side	Max. Draw Bar Force (kN(kgf)) Push Side / Pull Side	Piston Stroke (mm)	Max. Operating Pressure (MPa(kgf/cm²))	Max. Speed (r.p.m.)	Moment Of Inertia I (kg·m²)	Weight (kg)	Total Leakage (L/min)
MH80	80	47.7 / 42.8	15.5(1580) / 13.9(1417)	15	3.5(35.7)	6000	0.005	5.1	0.4
MH100F	100	75.4 / 70.5	24.5(2498) / 22.9(2335)	20	3.5(35.7)	5500	0.013	6.7	0.4
MH125F	125	121.1 / 114	39.3(4007) / 37(3773)	25	3.5(35.7)	5500	0.021	8.6	0.4
MH150F	150	176 / 160	66(6730) / 60(6118)	30	4.0(40.8)	4000	0.049	10.8	0.8

DIM Model	B	D	D1	E (h7)	F	G max.	G min.	H	J	K	L	L1	L2	M	P	Q	R	T	U	S
MH80	112	90	—	65	25	45	30	6	73.5	103	6-M8x16	—	—	M16x2.0x32	45	15.5	30.5	38	13.5	22
MH100F	135	100	115	80	25	45	25	6	88.5	103	6-M10x19	6-M8x90	12	M16x2.0x32	45	15.5	30.5	38	13.5	22
MH125F	160	130	140	110	30	51	26	6	95.5	103	6-M12x20	6-M8x100	13	M20x2.5x32	45	15.5	30.5	38	13.5	27
MH150F	190	130	170	110	45	50	20	6	107	103	12-M12x20	8-M10x110	16	M30x3.5x40	45	15.5	30.5	38	13.5	38

HB4

Boring mill jaw

1. Clamping of workpiece for larger size lathe, vertical lathe, die set with jig.
2. One set of 4-piece with T-bolt.

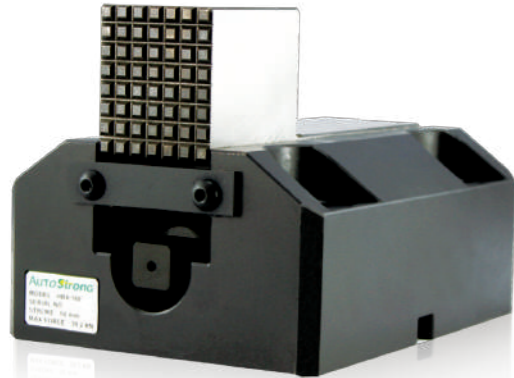

Product schematic

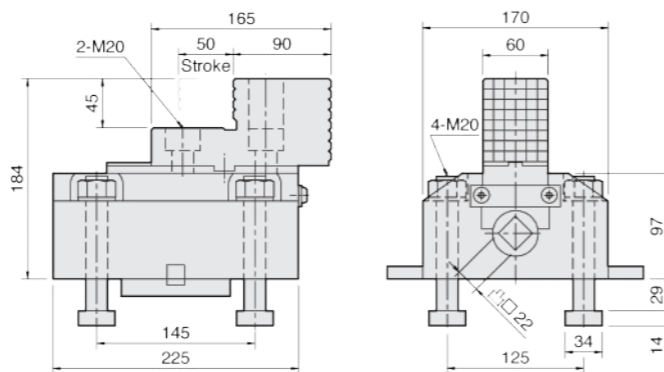
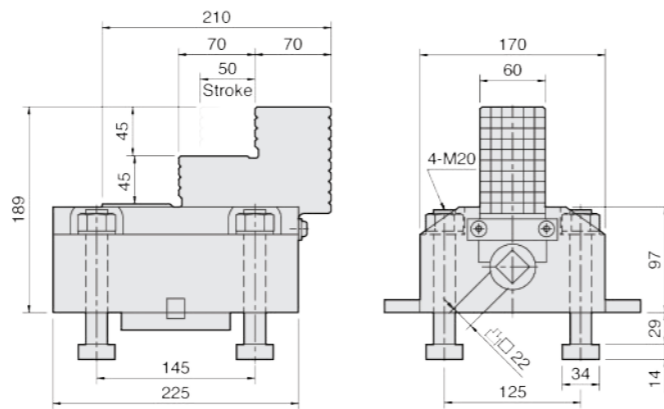
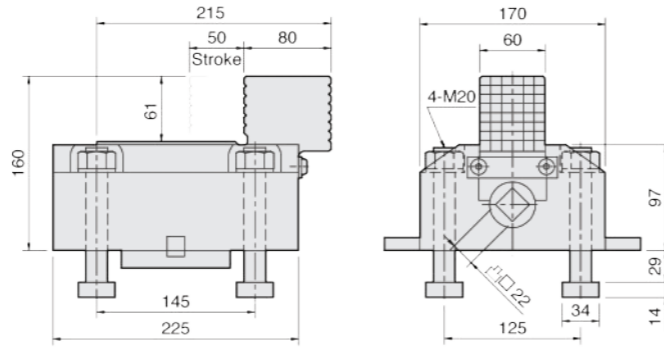

SPEC Model	Jaw Stroke (mm)	Max. Gripping Force (kN)	Weight (kg)
HB4-160	50	39.2	29

SPEC Model	Jaw Stroke (mm)	Max. Gripping Force (kN)	Weight (kg)
HB4-189	50	39.2	31

SPEC Model	Jaw Stroke (mm)	Max. Gripping Force (kN)	Weight (kg)	Matching Soft Jaw
HB4-2P	50	39.2	31	HE2486

SKC

Soft jaw for strong scroll chuck

1. Soft jaws for strong scroll chuck.
2. Manufactured in special specification.

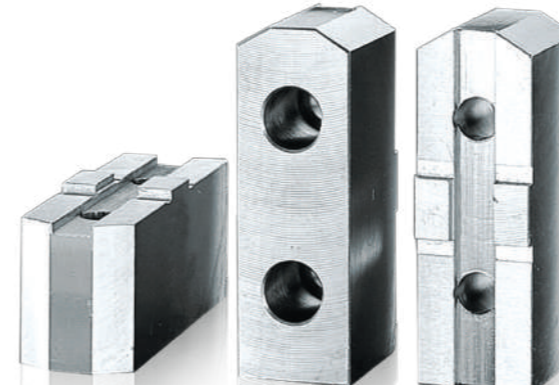

Product schematic

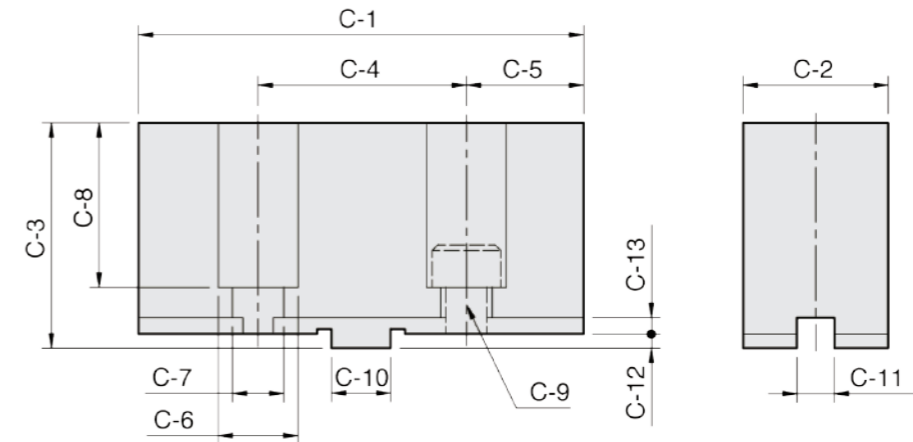

SPEC Model	C-1	C-2	C-3	C-4	C-5	C-6	C-7	C-8	C-9	C-10	C-11	C-12	C-13	Matching Chuck	3 Jaw Weight (kg)
SKC04	52	19	30	24	14	11	7	21	M6	9.53	7.94	2.5	3.5	SK-4	0.45
SKC06	73	26	37	38.1	17.45	14	9	25	M8	12.68	7.94	3	3.5	SK-6, KD-6"	1.5
SKC07	95	31	48	44.45	25.275	17	11	34	M10	12.68	7.94	3	3.5	SK-7, SK-8, KD-8", KA-8"	2.7
SKC09	110	37	48	54	28	19	13	34	M12	19.03	12.7	3	3.5	SK-9, SK-10, KD-10", KA-10"	3.7
SKC12	125	40	54	63.5	30.75	19	13	38	M12	19.03	12.7	3	3.5	SK-12, KD-12", KA-12"	4.9
SKC16	160	50	70	76.2	41.9	25	17	48	M16	19.03	12.7	6	6	SK-16	11
HE2486	155	59	86	76.2	52.9	32	21	66	M20	19.03	12.7	6	4	HB4-2P	19.2(4PC)



Product schematic

HC

Soft jaw for hydraulic power chuck

1. Soft jaws for hydraulic power chucks.
2. Soft jaw for CNC lathe.

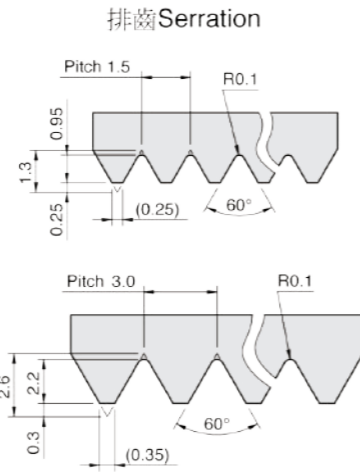
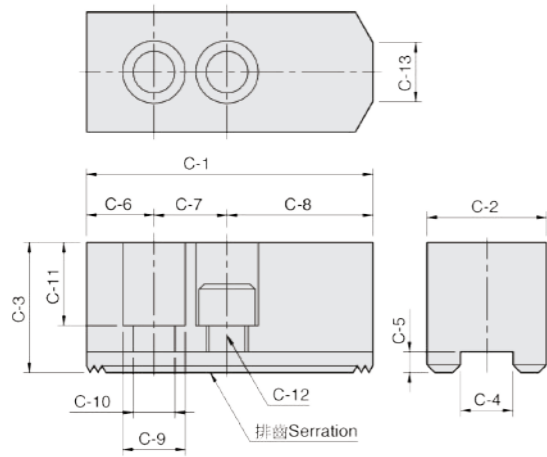

DIM Model	C-1	C-2	C-3	C-4	C-5	C-6	C-7	C-8	C-9	C-10	C-11	C-12	C-13	Serration Pitch	Matching Chuck	3 Jaw Weight (kg)
HC04	52	23	23	10	5	10	14	28	14	9	13	M8	3	1.5x60°	N-204	0.45
HC05	62	25	30	10	5	10	14	38	14	9	20	M8	3	1.5x60°	N-205, V-205	0.7
HC06	73	31	36	12	5	15	20	38	17	11	24	M10	14	1.5x60°	N-206, NB-306, NL-06, V-206	1.5
HC08	95	35	37	14	5	24	25	46	19	13	22	M12	16	1.5x60°	N-208, NB-208, NL-08, V-208	2.4
HC10	110	40	42	16	5	30	30	50	19	13	27	M12	18	1.5x60°	N-210, NB-210, NL-10, V-210	3.7
HC12	130	50	50	21	5	40	30	60	25	17	30	M16	23	1.5x60°	N-212, NB-212	6.5
HC15	165	62	62	22	8	37	43	85	32	21	37	M20	—	1.5x60°	N-215, N-218, NB-215, NB-218	12.5
HC08-1	95	35	37	12	5	24	20	51	17	11	22	M10	16	1.5x60°	NHT-208	2.4
HC12-1	130	50	50	18	5	40	30	60	23	15	30	M14	23	1.5x60°	V-212, V-212R	6.6
HC15-1	165	62	62	25.5	6	37	43	85	32	21	37	M20	—	1.5x60°	V-215, V-218, V-215R, V-218R	12.5
HC24-1	180	64	70	25	9	40	60	80	32	21	45	M20	—	3.0x60°	N-220, N-224, V-221, V-224, V-221R, V-224R	15.8
HC32-1	210	74	90	25	9	40	80	90	32	21	65	M20	—	3.0x60°	V-232R	29.2
HC15-2	156	64	70	26	9	34	50	72	32	21	45	M20	—	3.0x60°	V-215(P3.0), V-218(P3.0)	13.4

UNIT : mm

Soft jaw for draw down power chuck

DIM Model	C-1	C-2	C-3	C-4	C-5	C-6	C-7	C-8	C-9	C-10	C-11	C-12	C-13	Matching Chuck	3 Jaw Weight (kg)	Reference
DR-06	70	35	34	10	6	43	—	10	23	15.5	21	M14	2.5	DR-06	1.5	Fig-1
DR-08	84	40	44.5	16	7	53	26	12	20	13.5	29	M12	3.5	DR-08	2.7	Fig-2
DR-10	100	50	49.5	18	7	62	32	15	23	15.5	32	M14	3.5	DR-10	4.6	Fig-2
DR-12	120	60	54.5	20	7	78	36	17	26	17.5	36	M16	3.5	DR-12	7.5	Fig-2

UNIT : mm

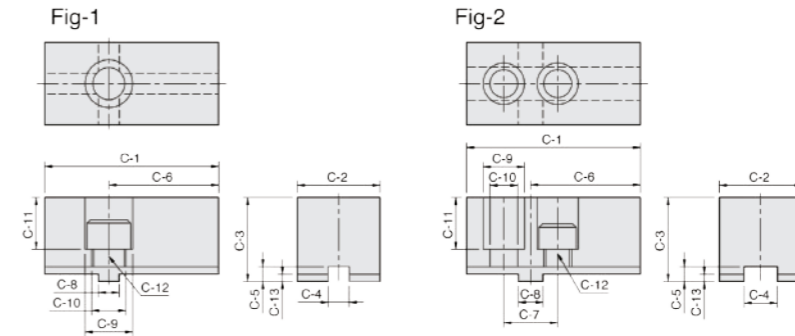

Soft jaw for ball swing lock chuck

DIM Model	C-1	C-2	C-3	C-4	C-5	C-6	C-7	C-9	C-10	C-11	C-12	Matching Chuck	3 Jaw Weight (kg)
BL-12	108	70	70	57.1	3.3	19	44.45	25	17	59	M16	BL-12	10.6

UNIT : mm

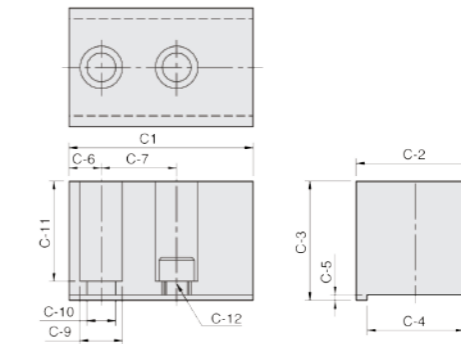

Soft jaws for pneumatic power chuck

DIM Model	C-1	C-2	C-3	C-4	C-5	C-6	C-7	C-8	C-9	C-10	C-11	C-12	C-13	Matching Chuck	3 Jaw Weight (kg)
PB600	205	60	60	25.5	6	25	38	104	32	21	44	M20	55	PB-ES600	13.5
PB850	320	80	80	30	7	35	60	165	38	26	53	M24	110.5	PB-ES850	40.2

UNIT : mm

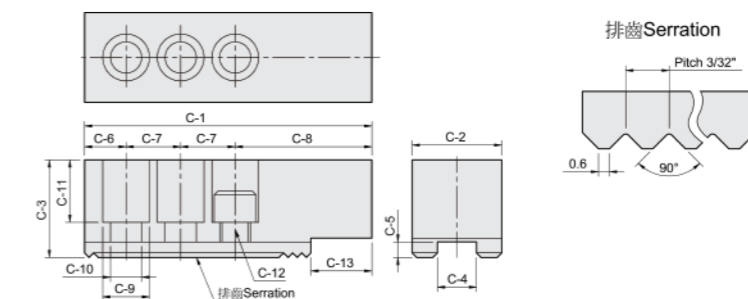

HC40-1

Soft jaw for hydraulic power chuck



Product schematic

Weight
17 kg / PC

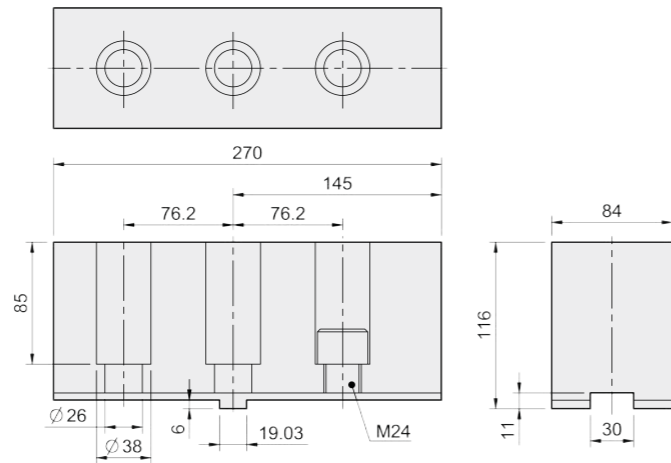

HJ40-1

Hard jaw for hydraulic power chuck



Product schematic

Weight
11 kg / PC

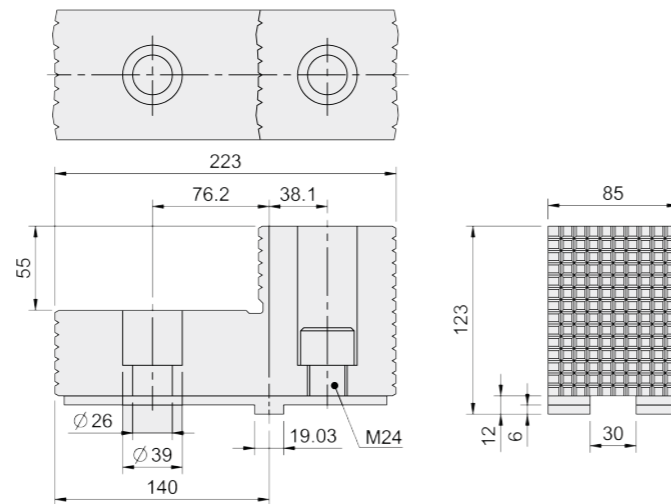

HJ

Hard jaw for hydraulic power chuck

1. Hard jaw for hydraulic power chucks.
2. Hard jaw for CNC lathe.



Product schematic

Fig-1

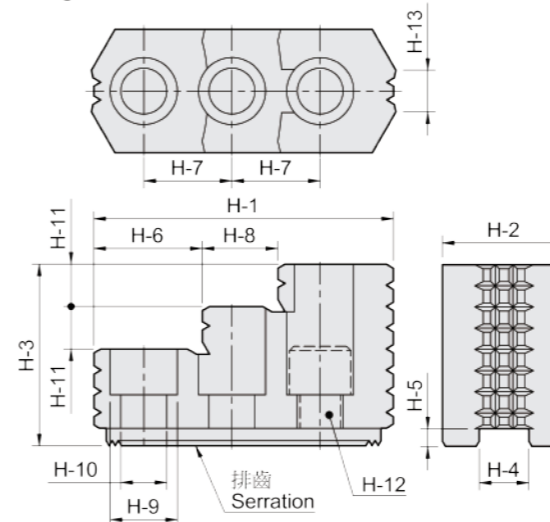
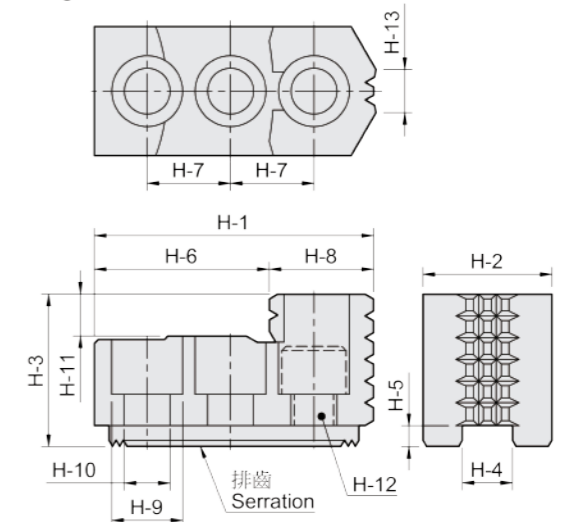

Fig-2



SPEC Model	H-1	H-2	H-3	H-4	H-5	H-6	H-7	H-8	H-9	H-10	H-11	H-12	H-13	Serration Pitch	Reference	Matching Chuck	3 Jaw Weight (kg)
HJ05	53	23	27.5	10	4	30.5	14	22.5	13.5	8.5	10	M8	6	1.5x60°	Fig-2	N-204, N-205, V-205	0.4
HJ06	67	31	35	12	5	39.5	20	27.5	17	11	12	M10	11	1.5x60°	Fig-2	N-206, NL-06, V-206	1.0
HJ08	86	35	51	14	5	31	25	18	19	13	12	M12	12	1.5x60°	Fig-1	N-208, NL-08, V-208	1.9
HJ10	99.5	40	54	16	5	43	30	17	19	13	13	M12	15	1.5x60°	Fig-1	N-210, NL-10, V-210	2.9
HJ12	103	50	52	21	4	62.5	30	40.5	25	17	17	M16	30	1.5x60°	Fig-2	N-212	3.5
HJ12-1	103	50	52	18	5	62.5	30	40.5	22	15	17	M14	30	1.5x60°	Fig-2	V-212	3.6
HJ15	149	62	86	22	8	63	43	34	32	21	20	M20	40	1.5x60°	Fig-1	N-215, N-218	9.6
HJ15-1	149	62	86	25.5	5	63	43	34	32	21	20	M20	40	1.5x60°	Fig-1	V-215, V-218	9.5
HJ24-1	159.5	80	90	25	9	104.5	50	55	32	21	40	M20	55	3.0x60°	Fig-2	N-220, N-224, N-232, V-221, V-224, V-232	14.3
PB600	140	60	75	25.5	6	50.35	38	49.86	31	21	19	M20	21.1	3/32"x90°	Fig-1	PB-ES600	7.2
PB850	220	75	85	30	6.5	130	62	90	38	26	30	M25	35	3/32"x90°	Fig-2	PB-ES850	20.2

UNIT : mm



ADAPTER

Mounting adapter on short taper spindle noses DIN55026

· Adaptor is suitable for short taper spindle with nose conforming to DIN55026.

Product schematic

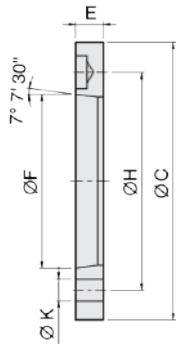

TYPE1

UNIT : mm

DIM Model	Spindle Nose	C	F	H	K	E	Matching Chuck
N-205A4	A4	110	63.513	82.55	3-11	15	N-205
NT-205A4	A4	110	63.513	82.55	4-11	15	NT-205
N-206A5	A5	140	82.563	104.78	6-11	15	N-206, NB-306, NL-06, V-206, DR-06
NT-206A5	A5	140	82.563	104.78	6-11	15	NT-206, VT-206
NIT-206A5	A5	140	82.563	104.78	4-11	15	NIT-206
N-208A6	A6	170	106.375	133.35	6-13	17	N-208, NB-208, NL-08, V-208, DR-08
NT-208A6	A6	170	106.375	133.35	6-13	17	NT-208, VT-208
NIT-208A6	A6	170	106.375	133.35	4-13	17	NIT-208
NHT-208A6	A6	170	106.375	133.35	6-13	17	NHT-208
N-210A8	A8	220	139.719	171.45	6-17	18	N-210, N-212, NB-210, NL-10, V-210, V-212, NB-310, V-212R, BL-12
NT-210A8	A8	220	139.719	171.45	6-17	18	NT-210, NT-212, VT-210, VT-212
NIT-210A8	A8	220	139.719	171.45	4-17	18	NIT-210, NIT-212, VIT-212
N-215A11	A11	300	196.869	235	6-21	22	N-215, N-218, NB-212, V-215, V-218, VIT-212R, V-215R, V-218R
NT-215A11	A11	300	196.869	235	6-21	22	NT-215, VT-215, NT-218
NIT-215A11	A11	300	196.869	235	4-21	22	NIT-215, VIT-218, NIT-218
V-224A15	A15	380	285.775	330.2	6-25	27	N-220, NB-215, NB-218, V-232RD, V-221R, V-224R, V-232R
VIT-224A15	A15	380	285.775	330.2	8-25	27	VIT-224R, VIT-232R
N-224A20	A20	520	412.775	463.6	6-25	25	N-224, N-232, V-240, V-250, NIT-224

TYPE2

UNIT : mm

DIM Model	Spindle Nose	C	F	H	K	G	V	E	Matching Chuck
N-206A4	A4	140	63.513	82.55	11	104.78	M10	20	N-206, NT-206, NIT-206, NL-06, V-206
N-208A5	A5	170	82.563	104.78	11	133.35	M12	23	N-208, NT-208, NIT-208, NHT-208, NB-208, NL-08, V-208, VT-208
N-210A6	A6	220	106.375	133.35	13	171.45	M16	25	N-210, NT-210, NIT-210, NL-10, N-212, NT-212, NIT-212, V-210, VT-210, V-212, VT-212, VIT-212, NB-210, NB-310
N-215A8	A8	300	139.719	171.45	17	235	M20	33	N-215, NT-215, NIT-215, N-218, NB-212, V-215, VT-215, V-218, VIT-218, NIT-218
N-220A11	A11	380	196.869	235	21	330.2	M24	41	N-220, VIT-232, NB-215, NB-218, VIT-224, V-232
N-224A11	A11	520	196.869	235	21	463.6	M24	45	N-224, N-232, V-240, V-250, NIT-224
N-224A15	A15	520	285.775	330.2	25	463.6	M24	42	N-224, N-232, V-240, V-250, VIT-240, VIT-250, NIT-224, VE-250
V-224A8	A8	380	139.719	171.45	17	330.2	M24	33	V-221, V-224, N-220, NB-215
V-224A11	A11	380	196.869	235	21	330.2	M24	27	V-221, V-224
VE-263A20	A20	720	412.775	463.6	27	647.6	M30	50	VE-263, VE-279

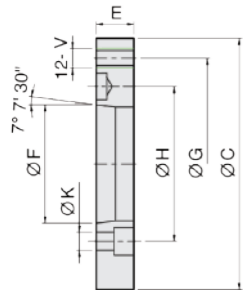

TYPE3

UNIT : mm

DIM Model	Spindle Nose	C	F	H	K	G	V	W	E	Matching Chuck
V-205A4	A4	80	63.513	82.55	11	100	6-M8	120	26.5	V-205
N-205A5	A5	110	82.563	104.78	11	82.55	M10	128	32	N-205, NT-205
N-206A6	A6	140	106.375	133.35	13	104.78	M10	165	35	N-206, NT-206, NB-306, NL-06, V-206, VT-206, NIT-206
N-208A8	A8	170	139.719	171.45	17	133.35	M12	208	40	N-208, NT-208, NIT-208, NB-208, NL-08, V-208, VT-208, NHT-208
N-212A11	A11	220	196.869	235	21	171.45	M16	278	50	N-210, NT-210, NIT-210, NL-10, N-212, NT-212, NIT-212, NB-210, V-210, VT-210, V-212, VT-212, VIT-212
N-215A15	A15	300	285.775	330.2	25	235	M20	378	57	N-215, NT-215, NIT-215, N-218, NB-212, V-215, VT-215, V-218, VIT-218, NIT-218
V-224A20	A20	380	412.775	463.6	26	330.2	M24	520	58	N-220, V-221R, V-224R, V-232R

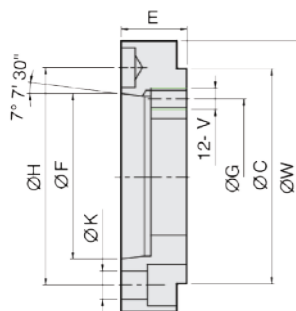

Product schematic

T-NUTS

Suitable for power chuck

· Suitable for hydraulic chuck.

Fig. 1

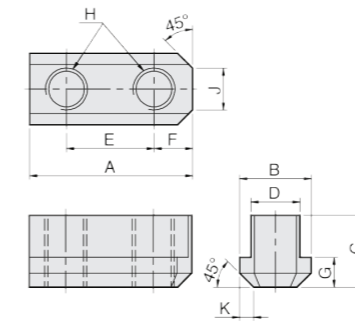

Fig. 2

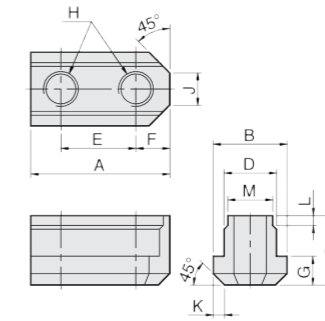
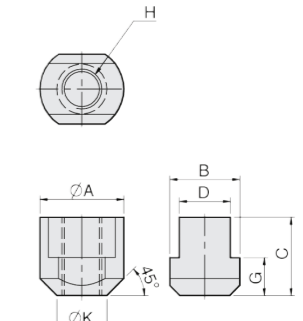
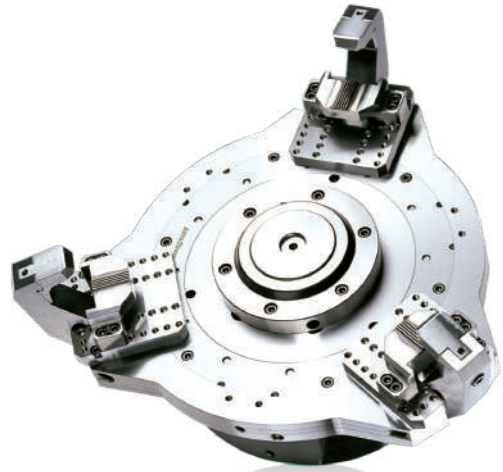

Fig. 3



UNIT : mm

DIM Model	A	B	C	D	E	F	G	H	J	K	L	M	Fig	Matching Chuck
N-205	26	14.5	15	10	14	6	5.5	M8	5	2	—	—	1	N-204, N-205
N-206	36	17.5	18.5	12	20	8.2	7.5	M10	8	2.5	—	—	1	N-206, NB-306, NL-06
N-208	46.5	20.5	20.5	14	25	10.5	8.5	M12	12	4	—	—	1	N-208, NB-208, NL-08
N-210	51	22.5	21.5	16	30	11	8.5	M12	11	3	—	—	1	N-210, NB-210, NL-10
N-212	55.5	29.5	27.8	21	30	12	11.5	M16	13	4.5	—	—	1	N-212, NB212
N-215	80	33.5	45.5	24	43	17	16.5	M20	11	5	8	22	2	N-215, N-218
V-206	36.5	17.5	22.5	12	20	7.5	7.5	M10	6	3	—	—	1	V-206, NHT-208
V-208	48	20.5	25.5	14	25	11	9.5	M12	8	4	—	—	1	V-208
V-210	55	22.5	25.5	16	30	11	9.5	M12	8	4	—	—	1	V-210
V-212	55.5	26.5	33.5	18	30	11.5	13.5	M14	11	5	—	—	1	V-212
V-215	42	35	39.2	25.5	—	—	19	M20	—	25	—	—	3	V-215, V-218
V-215 26 M20	42	35	41.2	26	—	—	19	M20	—	25	—	—	3	V-215P3.0
V-224	46	37.5	45	25	—	—	19	M20	—	26.5	—	—	3	N-220, N-224, V-221, V-224, V-232



Product schematic

F52

High speed and light weight type strong finger chuck for aluminum wheel

1. F52 type of aluminum rim chuck that is made of high-grade alloy steel. All sliding surfaces are hardening processed and grinding treated to improve rotation and durability. Manufactured in special specification.
2. The mating parts can be directly installed and conform to DIN, BS, ISO, ASA, B5-9, A-type main shaft standards.



Product schematic

F61

High speed and light weight type strong finger chuck for aluminum wheel

1. F61 type of aluminum rim chuck that is made of high-grade alloy steel. All sliding surfaces are hardening processed and grinding treated to improve rotation and durability. Manufactured in special specification.
2. The mating parts can be directly installed and conform to DIN, BS, ISO, ASA, B5-9, A-type main shaft standards.

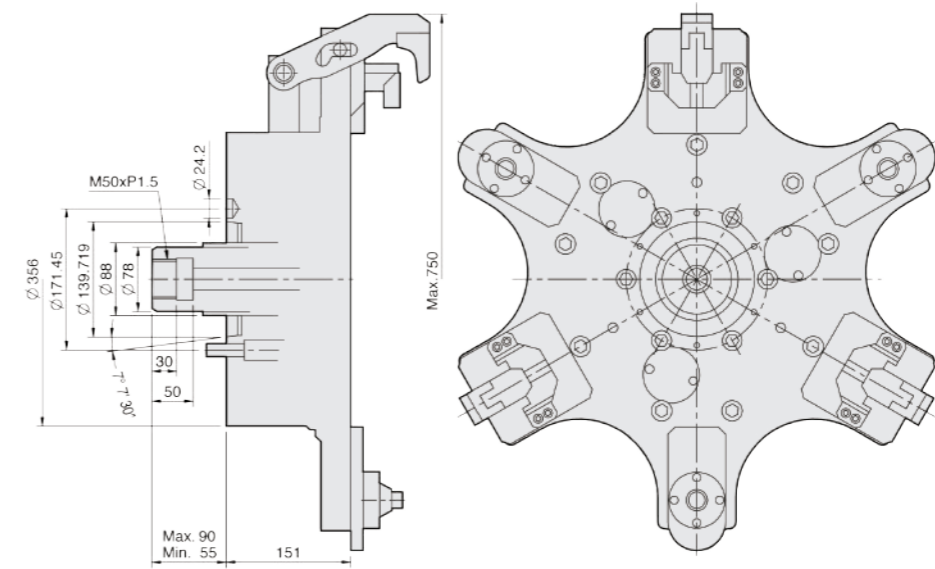
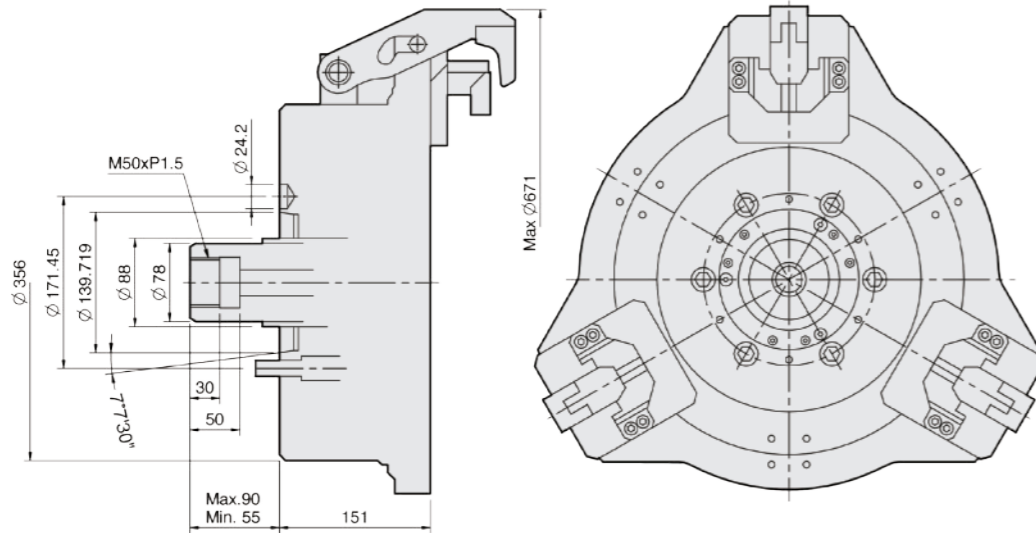

UNIT : mm

SPEC Model	Matching Wheel Size	Out Dai. Of Chuck (mm)	Matching Spindle	Max. Pull Force kN(kgf)	Max. Gripping Force kN(kgf)	Max. Operating Pressure MPa(kgf / cm ²)	Max. Speed (r.p.m.)	Weight (Without Jigs) (kg)	Matching Cylinder
F52A8	12"-18"	521	A2-8	33.9(3456)	32.4(3303)	3.3(33.6)	2800(18"2200)	98	MS125C35

UNIT : mm

SPEC Model	Matching Wheel Size	Out Dai. Of Chuck (mm)	Matching Spindle	Max. Pull Force kN(kgf)	Max. Gripping Force kN(kgf)	Max. Operating Pressure MPa(kgf / cm ²)	Max. Speed (r.p.m.)	Weight (Without Jigs) (kg)	Matching Cylinder
F61A8	13"-22"	610	A2-8	33.9(3456)	32.4(3303)	3.3(33.6)	1500	145	MS125C35

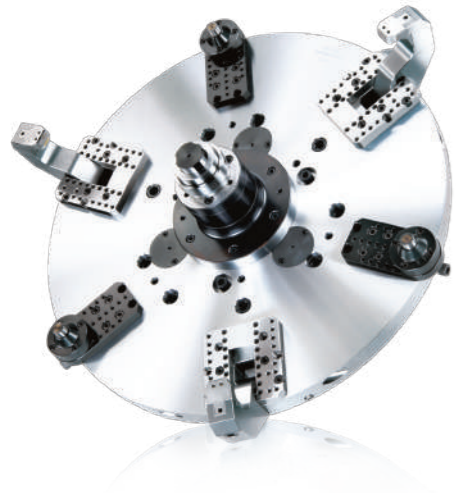

Product schematic

F66

High speed and light weight type strong finger chuck for aluminum wheel

1. F66 type of aluminum rim chuck that is made of high-grade alloy steel. All sliding surfaces are hardening processed and grinding treated to improve rotation and durability. Manufactured in special specification.
2. The mating parts can be directly installed and conform to DIN, BS, ISO, ASA, B5-9, A-type main shaft standards.



Product schematic

NL-A

3-jaw long stroke through-hole power chuck (adapter included)

1. Hollow type with super long stroke for crank structure
2. Made of high-strength alloy steel, the sliding surface is harden- processed and precisely ground.
3. Can clamp work piece of extreme different size at end faces.
4. The installation method is the same as the chuck of hollow N series, which are interchangeable directly.

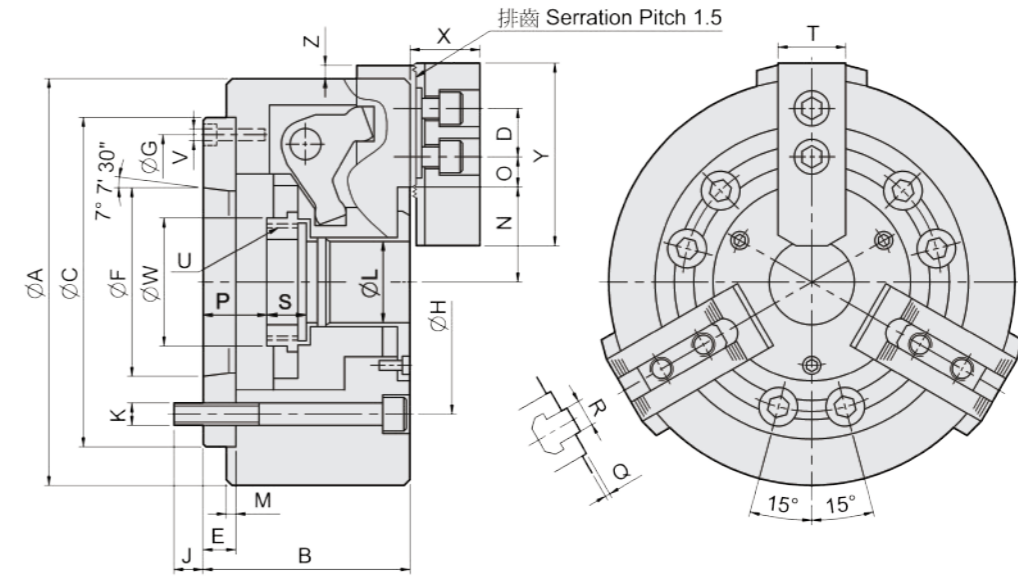
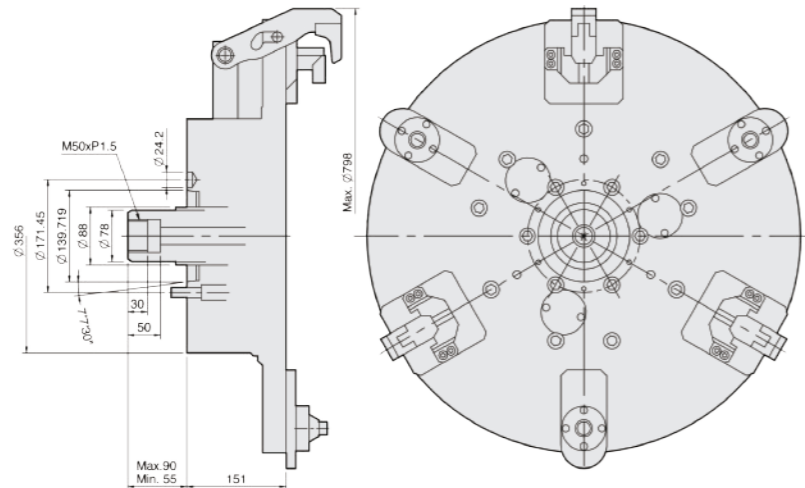

UNIT : mm

SPEC Model	Matching Wheel Size	Out Dia. Of Chuck (mm)	Matching Spindle	Max. Pull Force kN(kgf)	Max. Gripping Force kN(kgf)	Max. Operating Pressure MPa(kgf / cm ²)	Max. Speed (r.p.m.)	Weight (Without Jigs) (kg)	Matching Cylinder
F66A8	19"-24"	660	A2-8	33.9(3456)	32.4(3303)	3.3(33.6)	1500	182	MS125C35

UNIT : mm

SPEC Model	Through-Hole (mm)	Plunger Stroke (mm)	Jaw Stroke (In Dia.) (mm)	Max. Pull Force kN(kgf)	Max. Gripping Force kN(kgf)	Max. Operating Pressure MPa(kgf / cm ²)	Max. Speed (r.p.m.)	Weight (kg)	Moment Of Inertia I (kg · m ²)	Matching Cylinder	Matching Hard Jaw	Matching Soft Jaw	Gripping O.D. Range (mm)
NL-06A5	Ø40	15	24	2243	2651	28.5	3600	14.8	0.065	M1246	HJ06	HC06	Ø35-Ø168
NL-08A6	Ø48	20	32	3701	4190	27.5	3000	28	0.21	M1552	HJ08	HC08	Ø50-Ø215
NL-10A8	Ø66	25	37.5	4853	4486	29.5	2400	43.5	0.44	M1875	HJ10	HC10	Ø55-Ø256

UNIT : mm

DIM Model	A	B	C (H6)	D	E	F	G	H	J	K	L	M	N max.	O max.	O min.	P max.	P min.	Q	R	S	T	U max.	V	W	X	Y	Z
NL-06A5	168	96	140	20	15	82.563	116	104.78	16	6-M10	40	5	49	16.75	7.75	26	11	2	12	19	31	M55x2	3xM6	60	37	73	10
NL-08A6	215	112	170	25	17	106.375	150	133.35	18	6-M12	48	5	60.5	20.75	11.75	31.5	11.5	2	14	20.5	35	M60x2	3xM6	66	38	95	10
NL-10A8	256	125	220	30	18	139.719	190	171.45	24	6-M16	66	5	74.5	24.75	11.25	26.5	1.5	2	16	25	40	M85x2	3xM8	94	43	110	12.5



Product schematic

BL

3-jaw ball swing lock chuck

- The chuck can attract the workpiece and hold it on.
The jaw operates in two stages :
Clamping pull back, so it can hold the workpiece exactly on the position in front of the chuck, and make it under the stable situation.
- The chuck can grasp the workpiece on both O.D. and I.D. clamping.
The chuck can switch between O.D. and I.D. clamping mode by a simple operation.
- The chuck can grasp the part of the taper. The chuck can exactly grasp the black surface of the cast irons, which has draft.
So the discard process can be ignored on the chucking part of the workpiece. (It can grasp up to a 20 degree taper when using a clipper.)
- The jaw can equalize on the O.D. clamping, so it can grasp the workpiece steady. (Jaw self-equalizing to max 5°)
- Dustproof performance is excellent. It is differ from regular general purpose chuck. It is structurally dustproof. Especially there is a dustproof seal in the part of lock arm to prevent the dust.

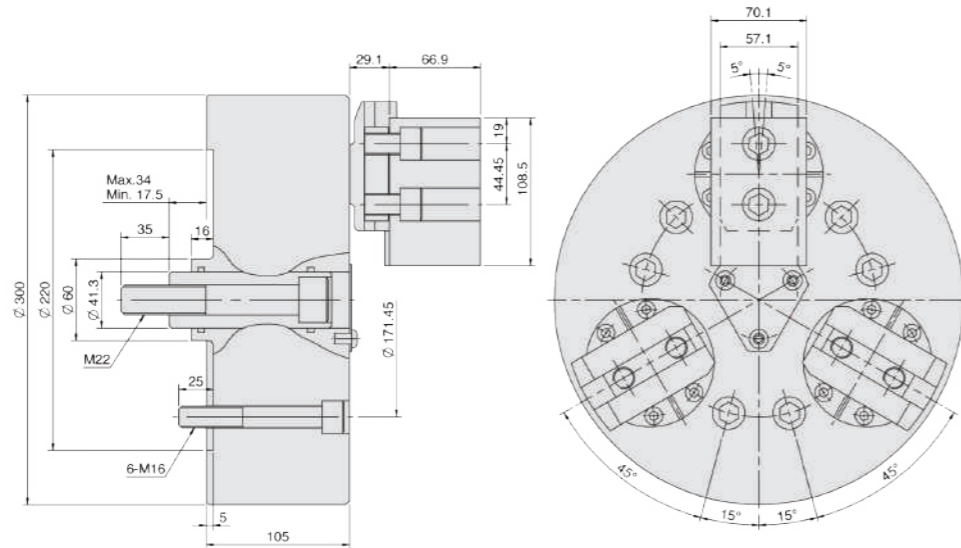

UNIT : mm

SPEC Model	Plunger Stroke (mm)	Jaw Stroke (In Dia.) (mm)	Max. Pull Force kN(kgf)	Max. Gripping Force kN(kgf)	Max. Operating Pressure MPa(kgf / cm ²)	Max. Speed (r.p.m.)	Weight (kg)	Moment Of Inertia I (kg · m ²)	Matching Cylinder	Matching Soft Jaw	Gripping Range O.D. Range / I.D. Range
BL-12	17.5	12.4	40.7(4152)	122(12440)	2.8(28.5)	2800	65	0.18	MS150C	BL-12	Ø63-Ø240 / Ø127-Ø305



Product schematic

DR

3-jaw draw down power chuck

- Back-pull hydraulic chuck for radial clamping and strong back-pull at same time, suitable for processing of castings and forgings
- Back-pull clamping keeps the work-piece appressed closely to the reference surface to make the clamping stable and suitable for heavy cutting.
- The cylindrical sliding structure supports the long-time usage and ensures excellent accuracy of repeated clamping.
- Accurate self-centering and strong clamping of the work piece without floatability. It is most suitable for those require lengthy and precise processing works.

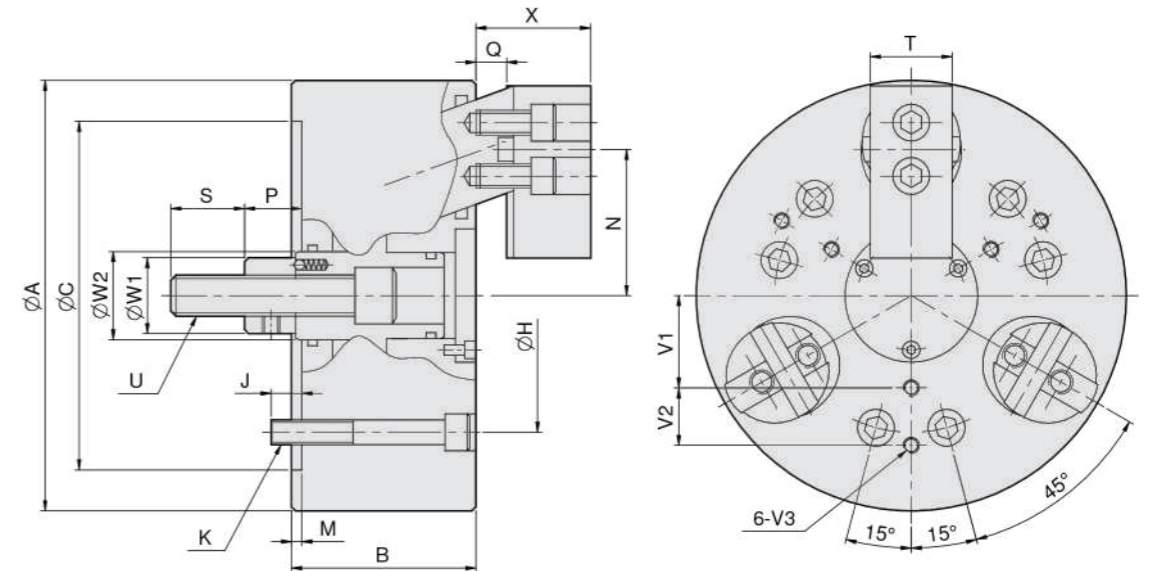

UNIT : mm

SPEC Model	Plunger Stroke (mm)	Jaw Stroke (In Dia.) (mm)	Max. Pull Force kN(kgf)	Max. Gripping Force kN(kgf)	Max. Operating Pressure MPa(kgf / cm ²)	Max. Speed (r.p.m.)	Weight (kg)	Moment Of Inertia I (kg · m ²)	Matching Cylinder	Matching Soft Jaw	Gripping O.D. Range (mm)
DR-06	10	7.2	15(1530)	25(2549)	2.1(21.4)	3500	15	0.05	MS105C	DR-06	Ø35-Ø165
DR-08	10	7.2	25(2549)	45(4589)	2.5(25.5)	3000	25	0.14	MS125C	DR-08	Ø40-Ø210
DR-10	16	11.6	35(3569)	60(6118)	3.3(34)	2500	46	0.374	MS125C	DR-10	Ø50-Ø254
DR-10D	16	11.6	35(3569)	60(6118)	3.3(34)	2500	46.1	0.376	MS125C	DR-10	Ø54-Ø254
DR-12	16	11.6	44(4487)	71(7240)	3(30.6)	2000	76	0.88	MS150C	DR-12	Ø50-Ø304

DIM Model	A	B	C	H	J	K	M	N max.	N min.	P max.	P min.	Q max.	Q min.	S	T	U	W1	W2	X max.	X min.	V1	V2	V3
DR-06	165	85	140	104.78	16	6xM10	5	58	54.4	33	23	14	4	36	35	M16x2.0	32	33.5	45	35	35	20	M6x12
DR-08	210	90	170	133.35	15	6xM12	5	71.3	67.7	38	28	15	5	36	40	M20x2.5	37	42	56	46	45	25	M8x16
DR-10	254	110	220	171.45	23	6xM16	5	85.4	79.6	48	32	20	4	46	50	M24x3.0	50	60	66	50	55	30	M8x16
DR-10D	254	110	220	171.45	23	6xM16	5	87.8	82	48	32	22.6	6.6	46	50	M24x3.0	50	60	68.6	52.6	85	30	M12x18
DR-12	304	125	220	171.45	23	6xM16	5	102.9	97.1	47	31	21.5	5.5	50	60	M27x3.0	52	60	72.5	56.5	100	35	M12x18



Product schematic

SB-ES

Pneumatic power chuck

1. Commonly used on lathes and turntables.
2. Suitable for Pneumatic chuck of outer diameter clamping that contains a structure of pneumatic cylinder.
3. Possess the feature of fast and clamping with two-stage jaw stroke.

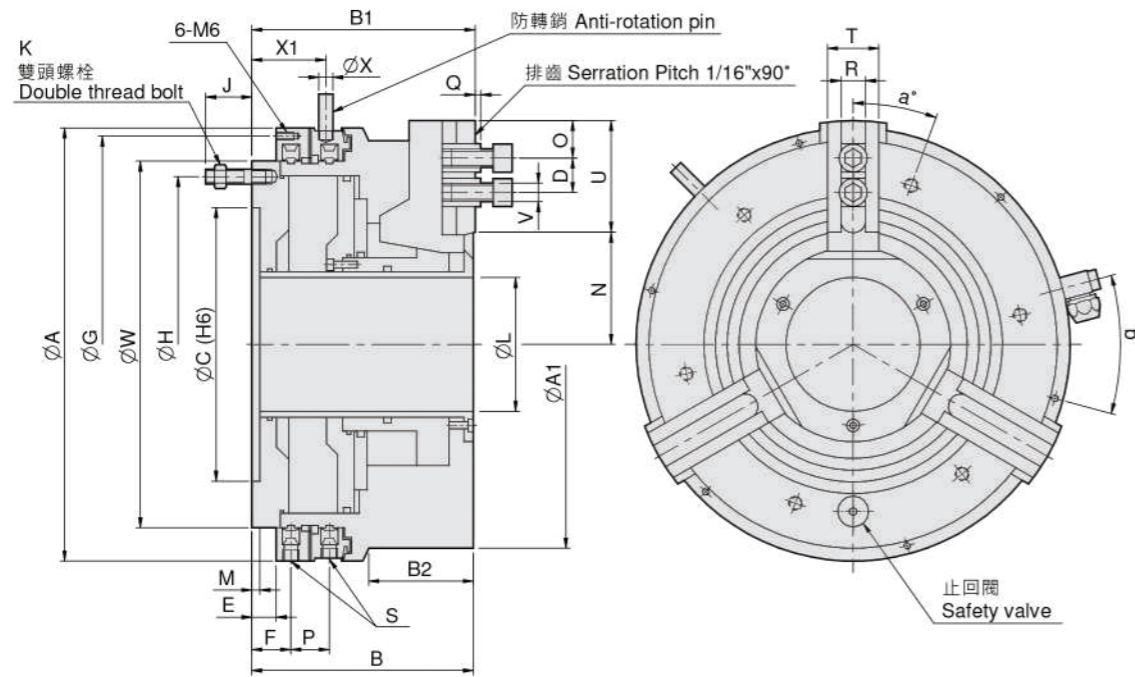

UNIT : mm

SPEC Model	Through-Hole (mm)	Total Jaw Stroke (mm)	Fast Jaw Stroke (mm)	Clamping Jaw Stroke (mm)	Piston Area (cm ²)	Operating Pressure Min.-Max. (bar)	Gripping Force (kN)	Max. Speed (r.p.m.)	Weight (kg)	Moment Of Inertia I (kg · m ²)	Air* Consumption (L)	Matching Hard Jaw	Matching Soft Jaw	Gripping O.D. Range (mm)
350-115	115	15	10	5	486	2-10	88	2200	104	1.82	13.5	SB350	SB350	Ø30-Ø360

*When operating pressure at 6 bar.

DIM Model	A	A1	B	B1	B2	C	D max./min.	E	F	G	H	J	K	L	M	N max./min.	O min.	P	Q	R	S	T	U	V	W	X	X1	a°	b°
350-115	372	360	190	191.5	92	235	64/28	21	33.5	358	290.5	39.5	6-M12	115	6.5	100/85	12	33	3	21	G1/4"	44	92	M16	315	12	61	20	15



Product schematic

PB-ES

Pneumatic power chuck

1. Suitable for Pneumatic chuck of outer diameter clamping that contains a structure of pneumatic cylinder.
2. Possess the feature of fast and clamping with two-stage jaw stroke.
3. Can check up the internal pressure during clamping.
4. Can check up clamping stroke.

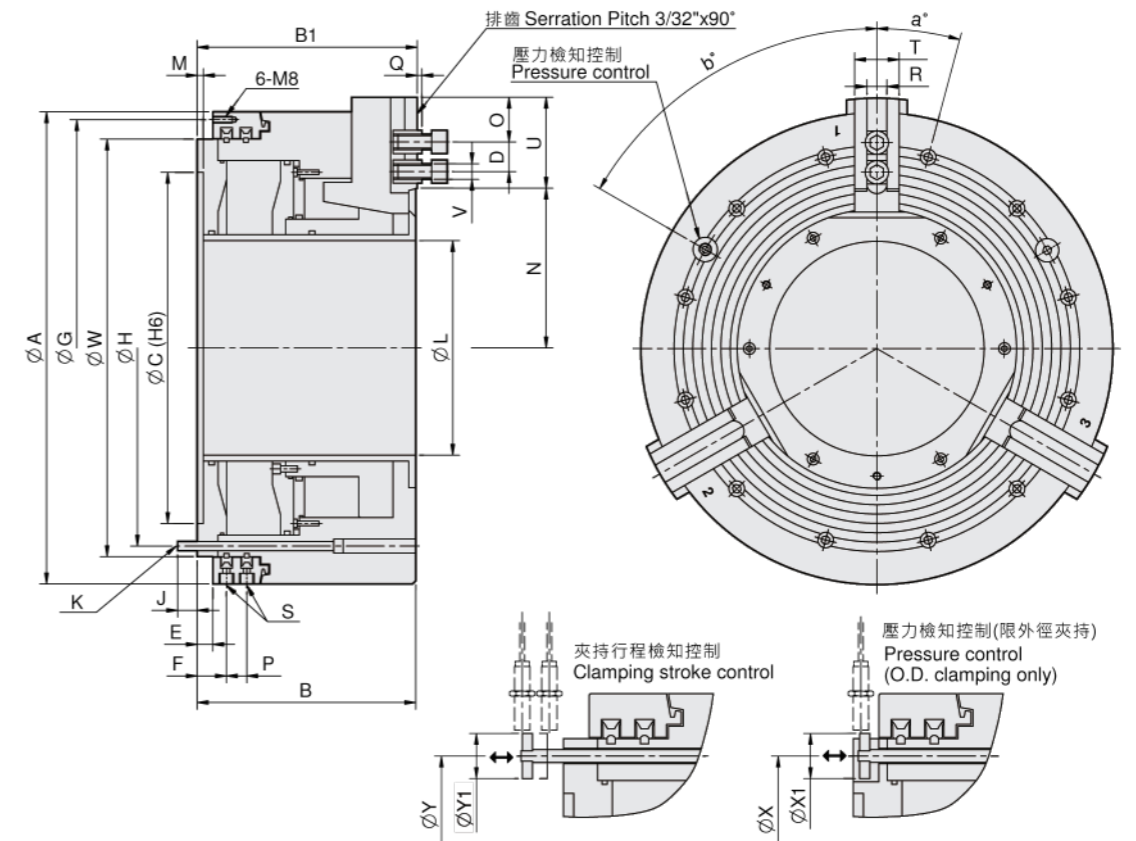

UNIT : mm

SPEC Model	Through-Hole (mm)	Total Jaw Stroke (mm)	Fast Jaw Stroke (mm)	Clamping Jaw Stroke (mm)	Piston Area (cm ²)	Operating Pressure Min.-Max. (bar)	Gripping Force (kN)	Max. Speed (r.p.m.)	Weight (kg)	Moment Of Inertia I (kg · m ²)	Air* Consumption (L)	Matching Hard Jaw	Matching Soft Jaw	Gripping O.D. Range (mm)
600-275	275	25.4	16.9	8.5	954	2-10	180	1100	360	20.6	39.5	PB600	PB600	Ø135-Ø275
850-375	375	25.4	13.4	12	1342	2-10	250	750	980	110	68	PB850	PB850	Ø115-Ø375

*When operating pressure at 6 bar.

DIM Model	A	B	B1	C	D max./min.	E	F	G	H	J	K	L	M	N max./min.	O min.	P	Q	R	S	T	U	V	W	X	X1	Y	Y1	a°	b°
600-275	605	280	282	450	79/38	20	37	585	508	25	12-M12	275	8	204.6/179.2	14	26	3	25.5	G1/2	57	116.5	M20	535	508	35	508	35	15	60
850-375	850	352	354	700	140/47	25	44.5	830	745	30	12-M16	375	8	268/242.6	16	33	4	30	G1/2	75	182	M24	775	745	35	745	35	15	60

