



POWER CHUCKS ROTARY CYLINDERS CLAMPING SERIES



www.autogrip.com.tw



AEROVIEW OF AUTOGRIP COMPANY

AUTOGRIP MACHINERY COMPANY

AUTOGRIP machinery was established in 1989 in Taiwan. Our product lines focus on the power chucks, rotary cylinders and automatic clamping series. We provide the optimized solutions and services for our customers worldwide.

LOCATION OF AUTOGRIP

Our factory locates in the middle part of Taiwan, the campus occupies 10,000 square meters. AUTOGRIP makes world-class high-quality products and services with high customer satisfaction.



AUTOGRIP[®]

AUTOGRIP MACHINERY CO., LTD.

AUTOGRIP'S BUSINESS PHILOSOPHY

With integrity and commitment, we provide the most professional products and services for the customers.

WE ARE FROM TAIWAN

All the products of AUTOGRIP are designed and made in our hometown-Taiwan. You can find that our products have a strong Taiwan spirit- solid and durable, with high rigidity and high precision.

Our company has a good reputation in the industry. AUTOGRIP is devoted to providing the optimized solutions and service for the workpiece clamping needs.



AUTOGRIP MECHANICAL TESTING LAB.



AUTOGRIP mechanical testing lab. continues to develop reliable test equipments and technique for controlling the product quality. Before the new product is launched to the market, the products will go through a series of tests to ensure that the performance and accuracy meet the design specifications. Products in the manufacturing process are also tested regularly to ensure the products are of good quality and consistent.

The Lab controls the quality for the customers and provides customers with the most satisfied experience when using the products.





DYNAMIC GRIPPING FORCE TEST

- The curve of gripping force against rotary speed is obtained via force sensor at a given test condition.

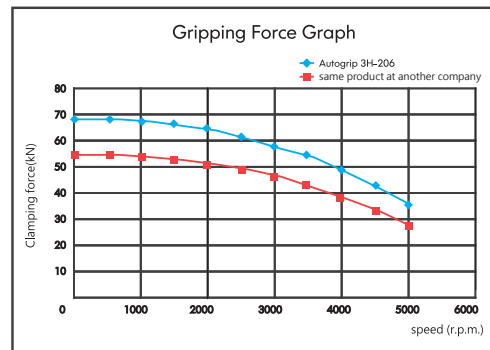

DYNAMIC OIL LEAKING TEST

- The oil leaking of cylinder is measured at different rotary speed to ensure it is within engineering specification.

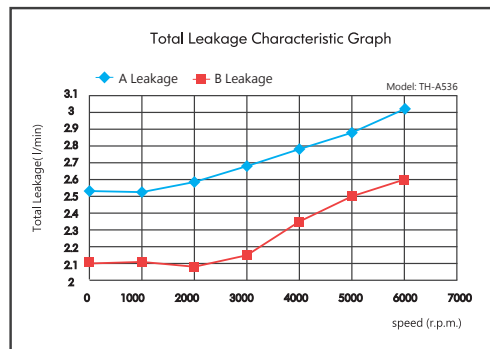

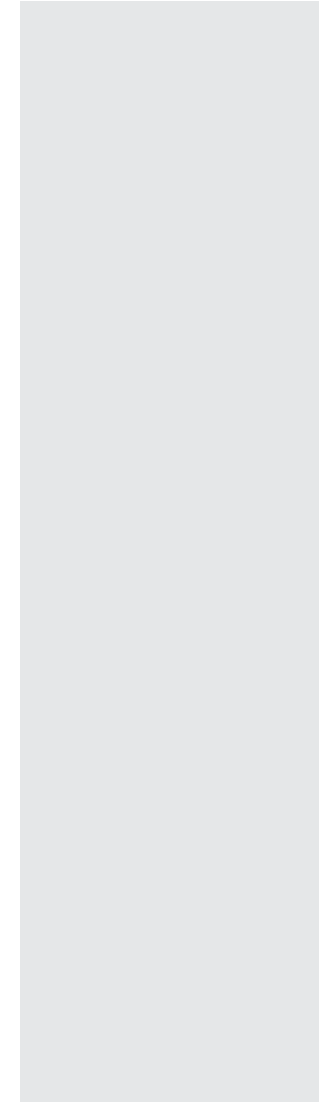
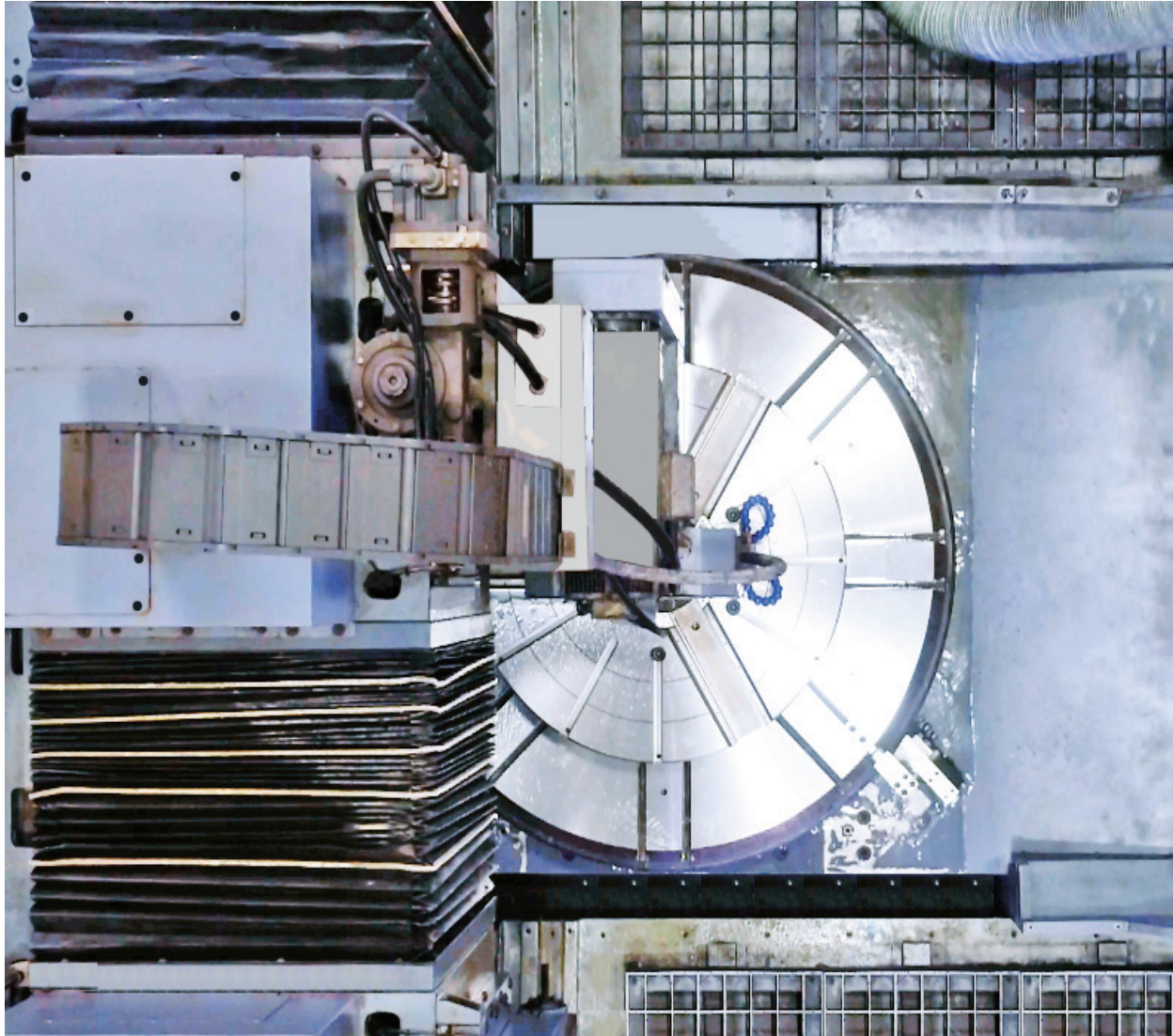



Why AUTOGRIP?

1. CUSTOM DESIGN SERVICE

Example: Solution of automatic workholding and workpiece seating confirmation, special requirement on air/hydraulic cylinder, rotary valve, rotary joint, or customized soft jaw/hard jaw.

2. VARIETY OF CHUCKS & CYLINDERS

Chuck: 1-jaw to 6-jaw chuck from 3" to 79", Extra long stroke, Pull back, Stationary chucks, Collet chucks and other clamping solution.

Cylinder: through-hole, Non-through hole, Stroke control, Coolant/air connection, Air cylinder, Double rod, Compact style.

3. FASTER DELIVERY AND SATISFIED SERVICE.





3W

SWING TYPE THREE-JAW POWER CHUCK

FEATURES

- Grip the work piece in radial direction and then pull down.
- Gripping on forging or casting part with taper up to 20°
- Jaw equalizing: 5°Max.
- Anti-dust and Seal proof for cutting fluid, easy to maintain.

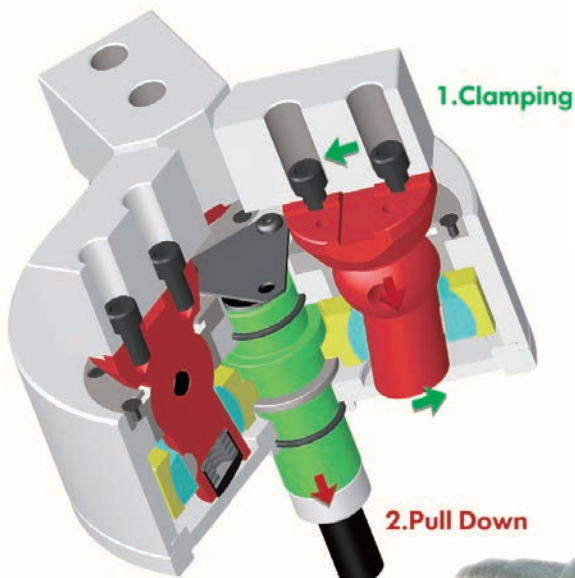
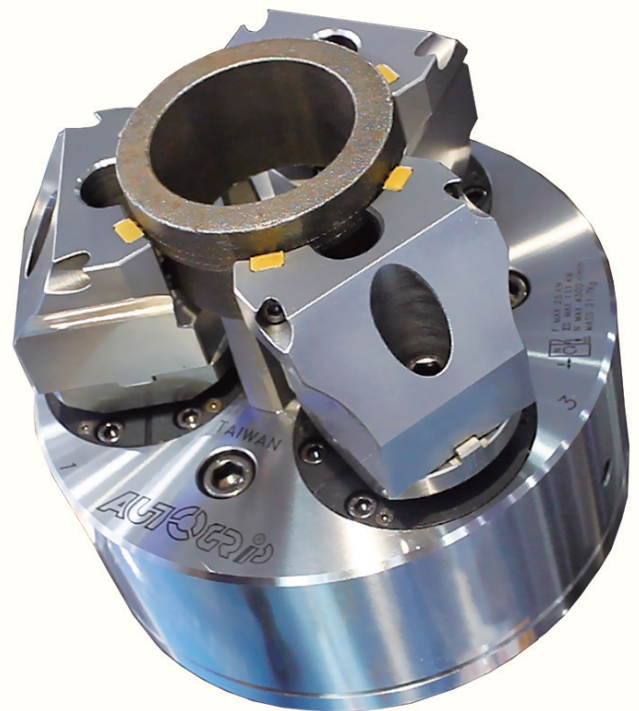

LARGE THRU-HOLE AIR CHUCK

AUTOGRIP



TAIWAN
EXCELLENCE 2018

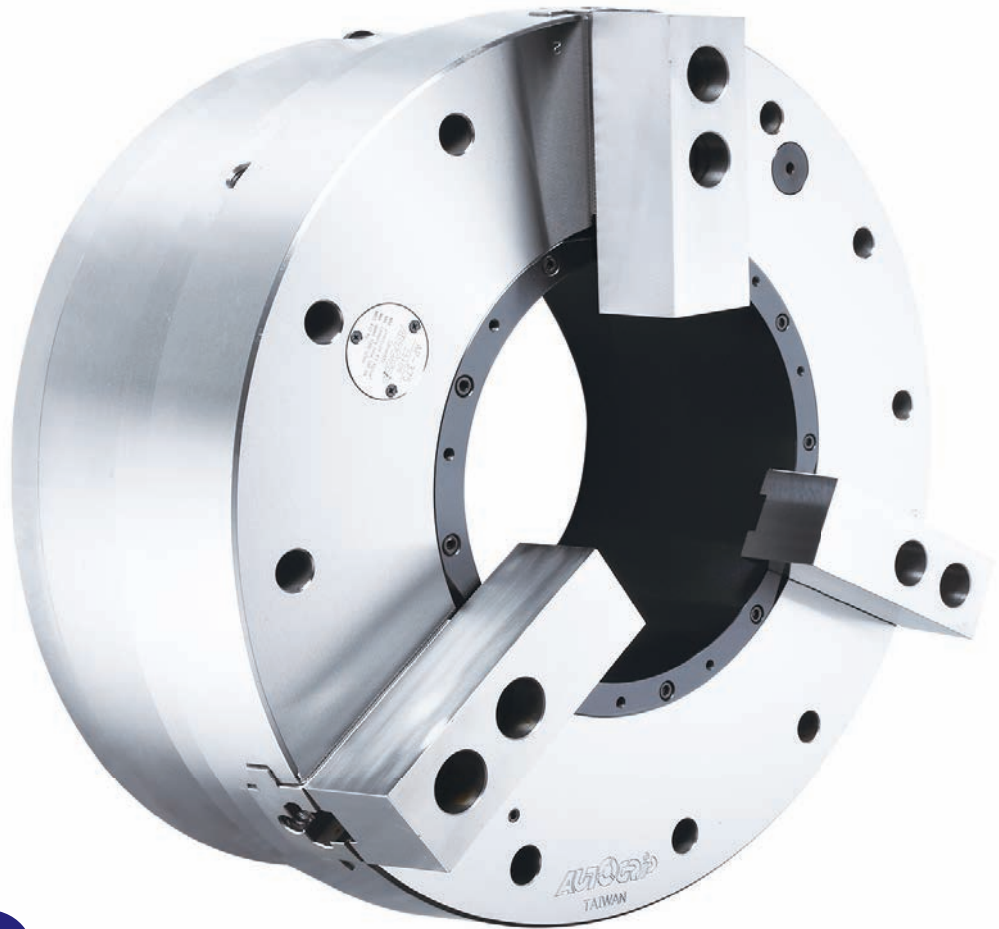

AP 3-JAW THRU-HOLE

FEATURES

- Large thru-hole : $\text{Ø}52\text{mm} \sim \text{Ø}375\text{mm}$.
- No distributor ring needed.
- Easy to install.
- Less maintenance.

PRODUCT PATENTED

US8770222 B2(U.S.A.)
M440159 / M415011 (Taiwan)
20.2011.101.818.4/20.2012.102.498.5(Germany)
3169457 / 3178706(Japan)
EP 2517822 B1(EU)
ZL 2011 2 0141324.9/ZL 2012 2 0274549.6(China)
0000278076(Italy)

PATENTED AIR FEED SYSTEM

- Built-in cylinder / Check valve.
- Pressure detection / Unique design.

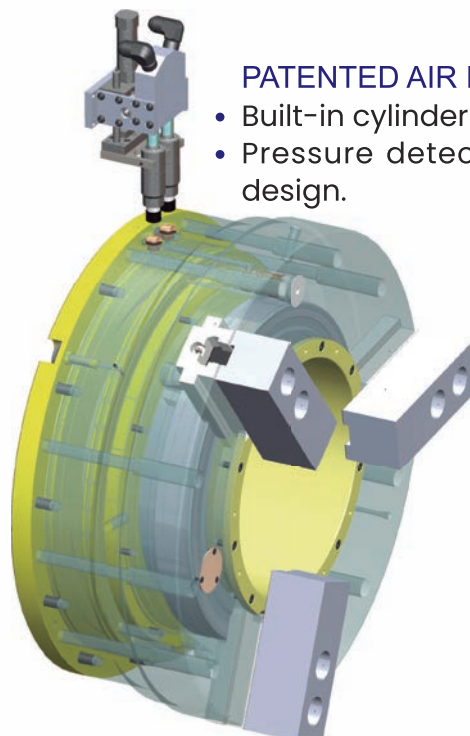

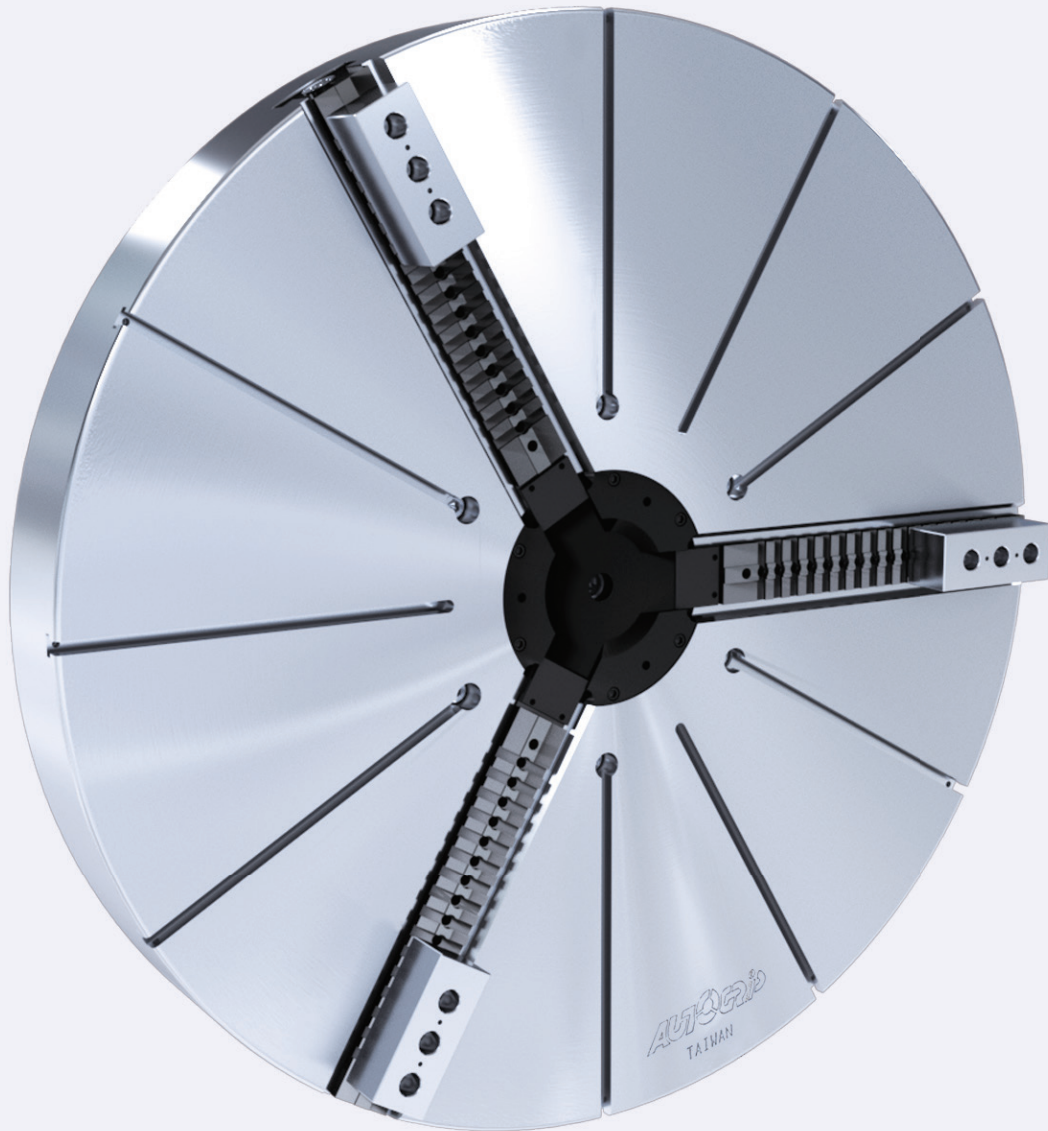

3V series

The maximum diameter is

2000mm (79")

FEATURES

- It's a WEDGE-HOOK type 3-jaw high speed power chuck.
- With manual radial setting of master jaws for the workpieces centering.
- Sealed against swarf, chips and coolant, suitable for vertical lathe.



- Various Models / Size: Available in 3, 4 and 6-jaw versions .
- with sizes 12 to 79 inch diameter.
- Rotary cylinder : RE series .

IS

Power Indexing Chuck

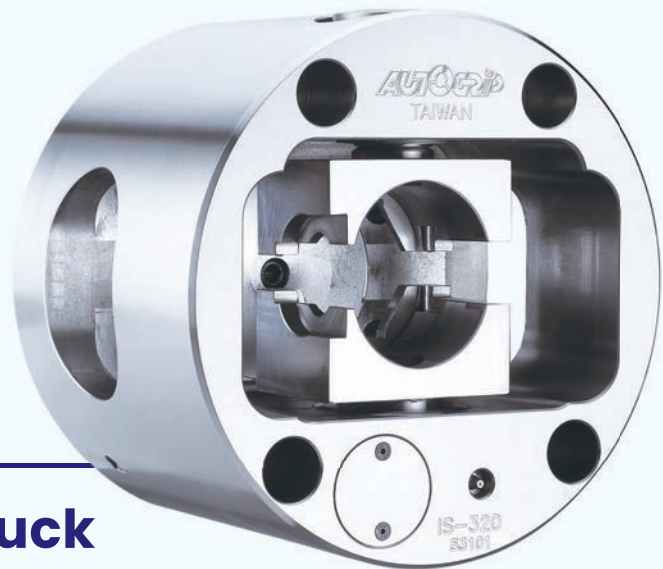

FEATURES

- Indexing operates during the spindle rotation, can perform a quick change between multiple working axes.
- All parts of chuck hardened, ground and lubricated directly.
- Sealed against swarf, chips and coolant.
- High rigidity and high repeatability precision.
- Unique indexing system and hydraulic system, with pressure detection device in chuck, high reliability.



STATIONARY CHUCK BASE PLATE

AUTOGRIP

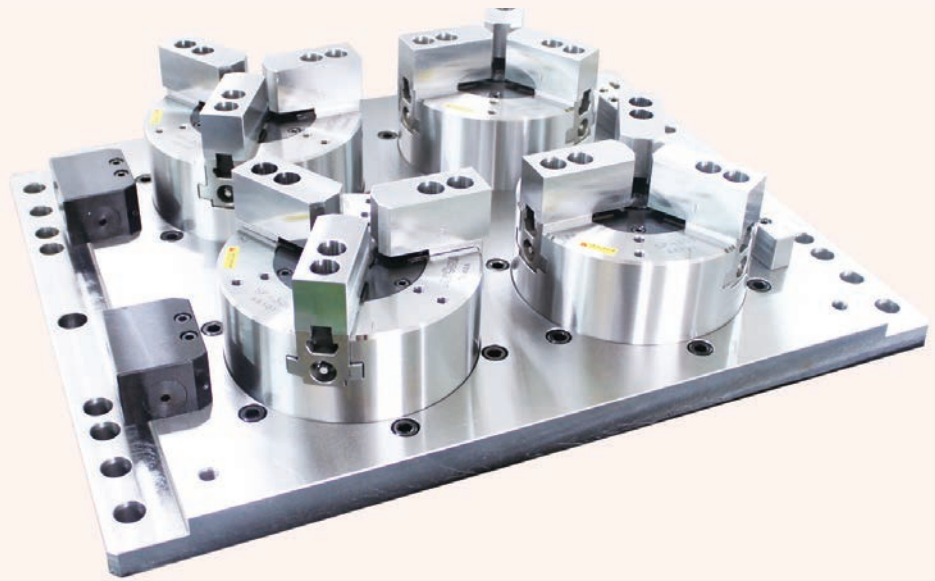

MP4

MULTI-PLATE.4-PLATE

FEATURES

- For milling machine / machine center.
- Allow simultaneous machining with up to 4 grippers. (Order can be customized for 2,3,6 grippers).
- Work with SP/SD/SU/SE vertical chuck.
- Driven by Hydraulic or Pneumatic.
- Individual circuit for each chuck.
- Special design and reduce the height of working surface.
- Lock valve unit (optional).
- Air tight detection function(optional).



STATIONARY CHUCK SERIES



SP-STATIONARY CHUCK

- Wedge-hook type.



SD-STATIONARY PULL DOWN CHUCK

- Pull down / Heavy duty machining / Air tight detection.



SU-STATIONARY PULL LOCK CHUCK

- Pull lock / Heavy duty machining / Air tight detection.



SE-STATIONARY EXPANSIBLE PULL LOCK CHUCK

- Pull lock / Inner dia. clamping / Air tight detection.

Recommended for you

Rubber Grip Collet

Lathe



CBD



RG

High gripping force / High accuracy / Quick jaw change

Quick change and easy. Dust-proof and swarf-proof design. Grip Range: $\pm 0.5\text{mm}$

Milling machine



SCB



RG

ROTARY CYLINDER & LINEAR POSITION SENSOR

AUTOGRIP

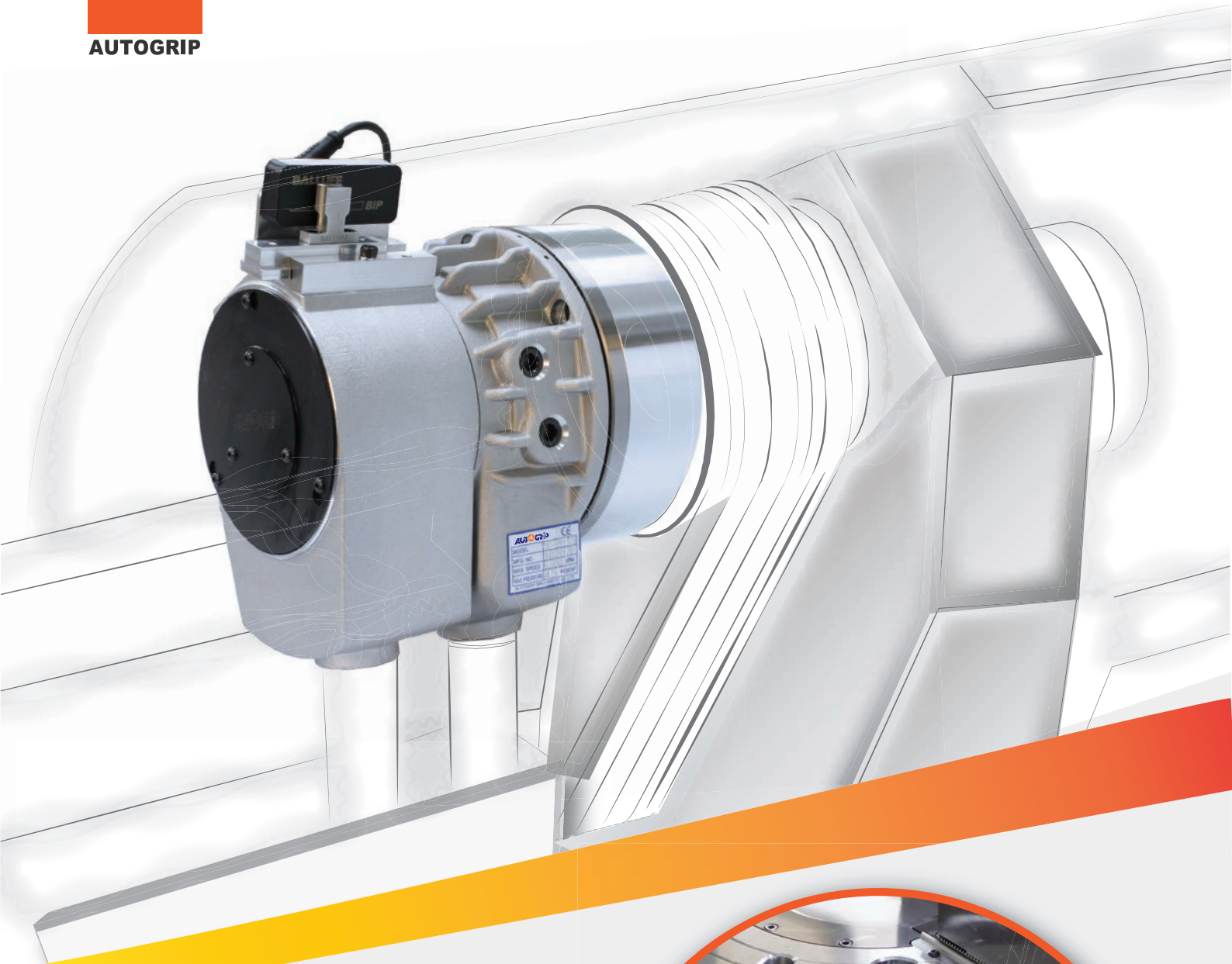

FEATURES

- Entire stroke range position monitoring.
- Position setup by teach-in function.
- Manual adjustment for proximity switch is unnecessary when changing workpiece.
- Suitable for sub-spindle or vertical lathes with limited space.
- Reduce idle time, increase throughput.



Vertical Lathe
Hydraulic Cylinder

HYDRAULIC CYLINDER WITH ROTATING JOINT

AUTOGRIP

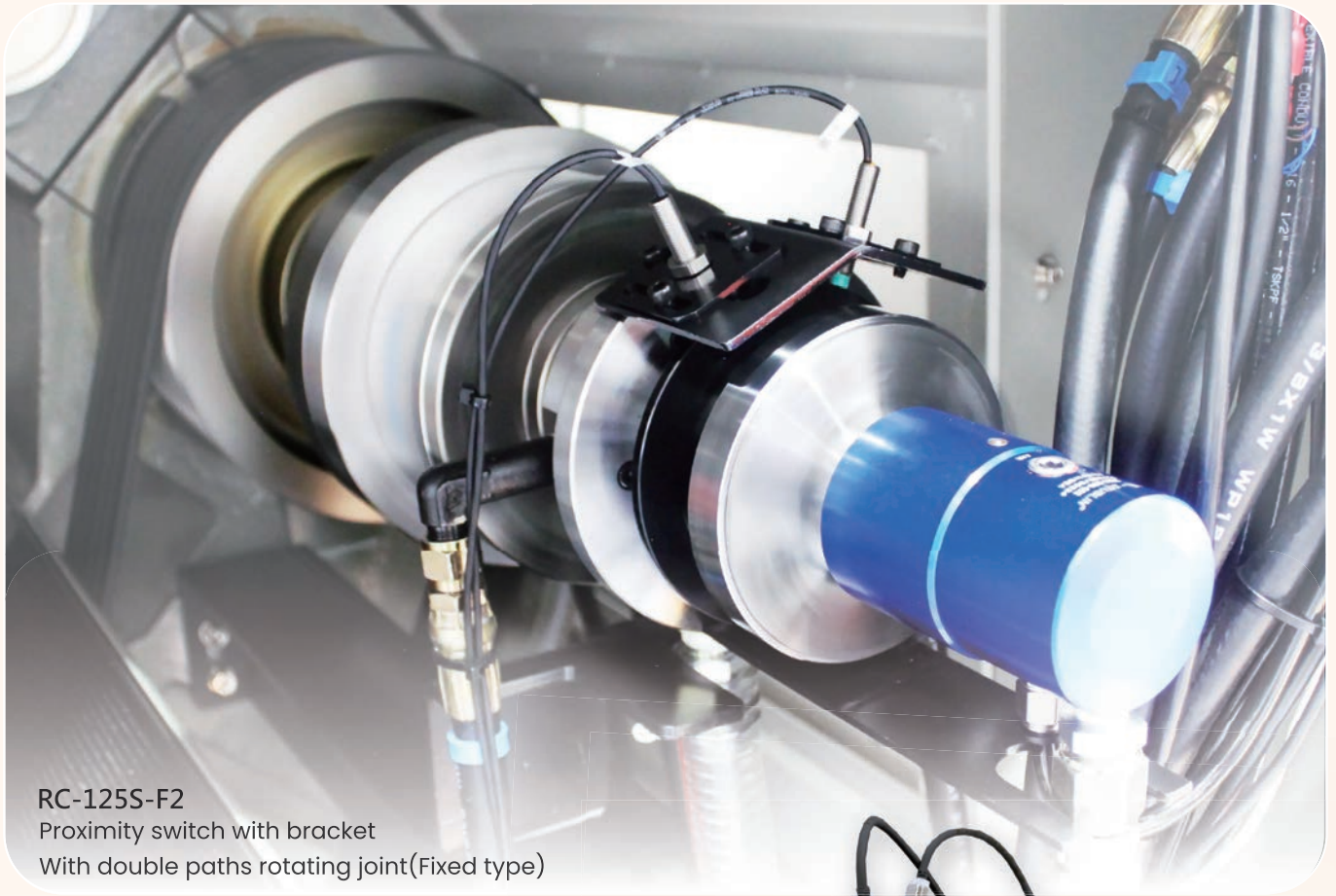

RC-125S-F2
Proximity switch with bracket
With double paths rotating joint(Fixed type)

RC series



HYDRAULIC CYLINDER WITH ROTATING JOINT

FEATURES



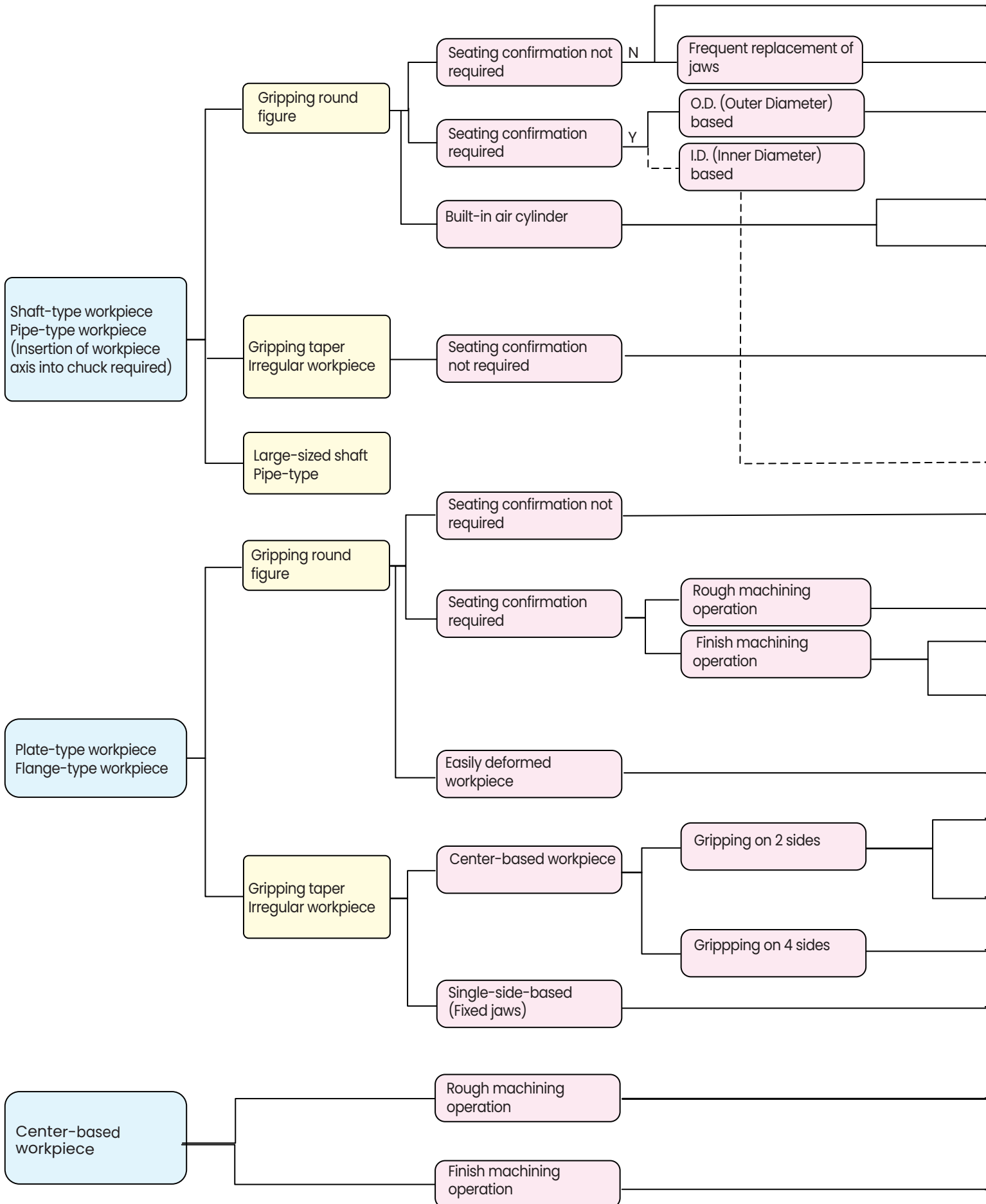

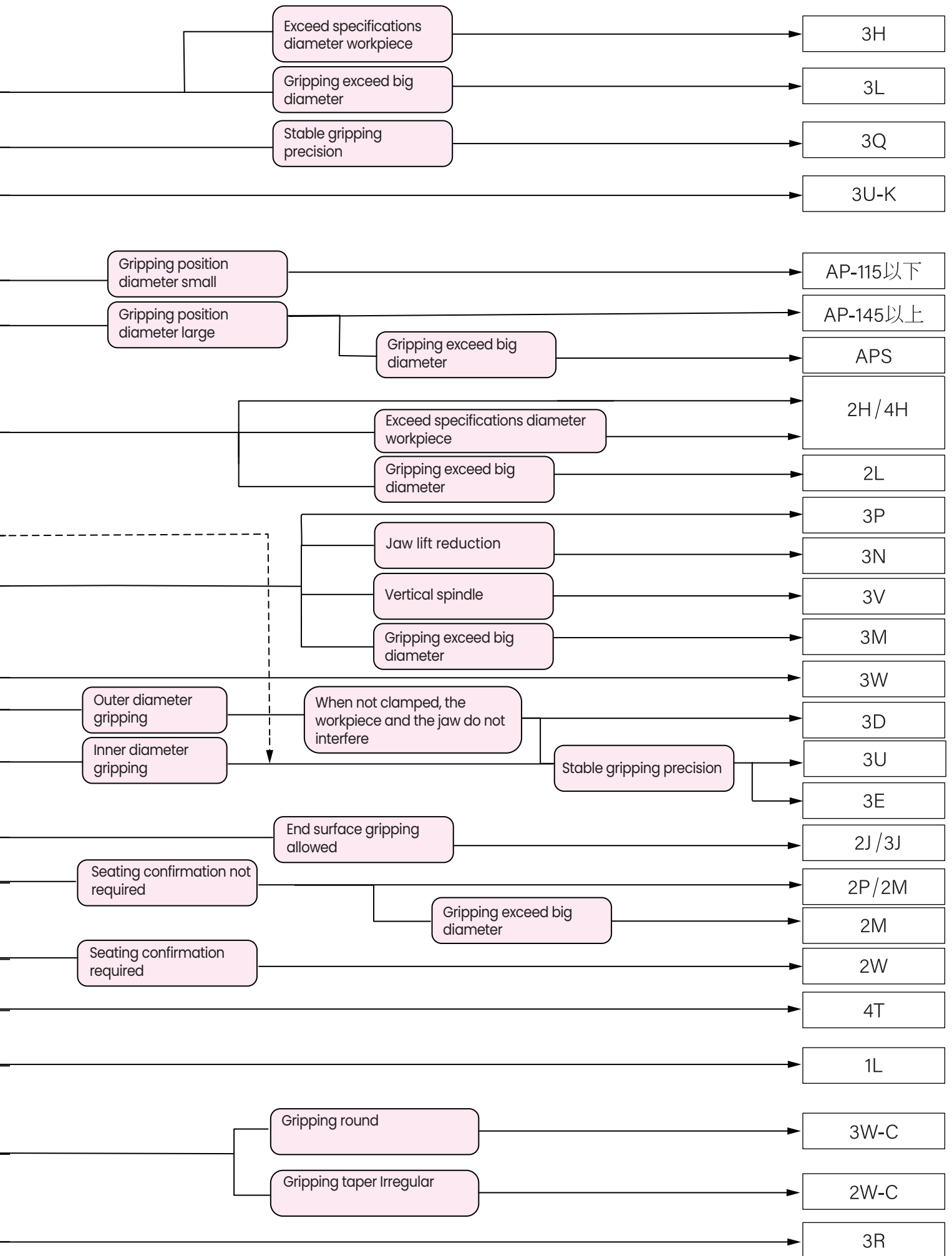









- Medium and solid hydraulic cylinder with channel.
- Can choose an external rotary joint with either single or double paths.
- It meets the demand for coolant through spindle and airtight pressure detect function.
- Has a built-in check valve for safety.
- The proximity switch and single or double paths rotating joint are optional.
- Stroke control via proximity switch or linear positioning system.





*The contents in this chart are subject to change without notice for further improvement, etc.

Power Chucks

 <p>3H-2/3H-2A LARGE THRU-HOLE POWER CHUCK THRU-HOLE 3-JAW</p> <p>1</p>	 <p>3H/3H-A THRU-HOLE POWER CHUCK THRU-HOLE 3-JAW</p> <p>3</p>	 <p>2H/2H-A THRU-HOLE POWER CHUCK THRU-HOLE 2-JAW</p> <p>4</p>
 <p>4H/4H-A THRU-HOLE POWER CHUCK THRU-HOLE 4-JAW</p> <p>5</p>	 <p>3P/3P-A POWER CHUCK NON-THRU-HOLE 3-JAW</p> <p>6</p>	 <p>2P/2P-A POWER CHUCK NON-THRU-HOLE 2-JAW</p> <p>9</p>
 <p>1L EXTRA LONG JAW STROKE POWER CHUCK NON-THRU-HOLE / 1-JAW</p> <p>10</p>	 <p>3L/3L-A EXTRA LONG JAW STROKE POWER CHUCK THRU-HOLE / 3-JAW</p> <p>11</p>	 <p>2L/2L-A EXTRA LONG JAW STROKE POWER CHUCK THRU-HOLE 2-JAW</p> <p>13</p>
 <p>3M LONG JAW STROKE POWER CHUCK NON-THRU-HOLE 3-JAW</p> <p>15</p>	 <p>2M LONG JAW STROKE POWER CHUCK NON-THRU-HOLE 2-JAW</p> <p>17</p>	 <p>3V-A POWER CHUCK FOR VERTICAL LATHE NON-THRU-HOLE 3-JAW</p> <p>18</p>
 <p>4V-A POWER CHUCK FOR VERTICAL LATHE NON-THRU-HOLE 4-JAW</p> <p>20</p>	 <p>3PS FULLY SEALED TYPE POWER CHUCK FULLY SEALED TYPE 3-JAW</p> <p>22</p>	

Special Purpose Power Chucks

 <p>3Q QUICK JAW-CHANGE CHUCK THRU-HOLE 3-JAW</p> <p>23</p>	 <p>3N INCLINED MASTER JAWS POWER CHUCK NON-THRU-HOLE 3-JAW</p> <p>24</p>	 <p>4T FOUR-JAW TWO MOTION TYPE POWER CHUCK NON-THRU-HOLE 4-JAW</p> <p>25</p>
 <p>3D PULL DOWN POWER CHUCK NON-THRU-HOLE 3-JAW</p> <p>26</p>	 <p>2D PULL DOWN POWER CHUCK NON-THRU-HOLE 2-JAW</p> <p>27</p>	 <p>3U PULL LOCK POWER CHUCK THRU-HOLE 3-JAW</p> <p>28</p>
 <p>3U-K PULL LOCK POWER CHUCK NON-THRU-HOLE 3-JAW</p> <p>29</p>	 <p>3E EXPANSIBLE PULL LOCK POWER CHUCK NON-THRU-HOLE 3-JAW</p> <p>30</p>	 <p>3W/3W-C SWING TYPE 3-JAW POWER CHUCK SWING TYPE 3-JAW</p> <p>31</p>
 <p>3RF RETRACTABLE-JAW 3-JAW SHAFT CHUCK COMPENSATING TYPE 3-JAW</p> <p>33</p>	 <p>3R SWING COMPENSATING TYPE 3-JAW POWER CHUCK COMPENSATING TYPE 3-JAW</p> <p>35</p>	 <p>3J FINGER POWER CHUCK NON-THRU-HOLE 3-JAW</p> <p>36</p>
 <p>2J FINGER POWER CHUCK NON-THRU-HOLE 2-JAW</p> <p>37</p>	 <p>AP LARGE THRU-HOLE AIR CHUCK THRU-HOLE 3-JAW</p> <p>38</p>	 <p>APS LARGE THRU-HOLE AIR CHUCK (DOUBLE SPEED JAW STROKE) THRU-HOLE / 3-JAW</p> <p>40</p>
 <p>IS POWER INDEXING CHUCK</p> <p>41</p>	 <p>RAP PNEUMATIC ROTARY CHUCK PNEUMATIC ROTARY TYPE</p> <p>42</p>	

Collet Chucks



CL
COLLET CHUCK
THRU-HOLE

43



CL-A
COLLET CHUCK
THRU-HOLE

44



CB/CB-A
DRAW BACK COLLET CHUCK
THRU-HOLE

45



CBE/CBE-A
END STOP COLLET CHUCK
THRU-HOLE

46



CBD/CBD-A
DEAD LENGTH COLLET CHUCK
THRU-HOLE

47



SCB
STATIONARY DRAW COLLET CHUCK
THRU-HOLE

48



RG
RUBBER GRIP COLLET

49



DIN6343
STEEL COLLET
STEEL COLLET

50

Stationary Chucks



VH
STATIONARY CHUCK WITH THRU-HOLE
THRU-HOLE STATIONARY
2/3-JAW

51



VP
STATIONARY CHUCK
NON-THRU-HOLE STATIONARY
2/3-JAW

52



SP
STATIONARY CHUCK
NON-THRU-HOLE STATIONARY
THRU-HOLE STATIONARY
2/3-JAW

53



SM
LONG JAW STROKE
STATIONARY CHUCK
NON-THRU-HOLE
2/3-JAW

55



SD
STATIONARY PULL
DOWN CHUCK
NON-THRU-HOLE
3-JAW

56



SU
STATIONARY PULL
LOCK CHUCK
NON-THRU-HOLE
3-JAW

57



SE
STATIONARY
EXPANSIBLE
PULL LOCK CHUCK
NON-THRU-HOLE
3-JAW

58



MP4
STATIONARY CHUCK
BASE PLATE

59



VH-201
HAND OPERATED
AIR VALVE
ACCESSORIES

59

Manual Chucks



3MF
SELF-CENTERING
3-JAW MANUAL
CHUCK
NON-THRU-HOLE
3-JAW

60

FACING HEADS



FA
SINGLE-SLIDE FACING
HEAD
SINGLE SLIDE

61



FD
DOUBLE-SLIDE FACING
HEAD
DOUBLE SLIDE

63

SYNCHRONOUS CLAMPS



ROTARY CYLINDERS

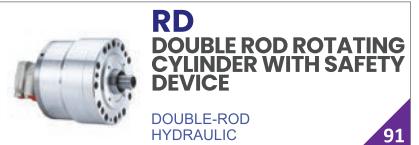

ROTARY VALVES / ROTARY JOINTS



PARTS AND ACCESSORIES



SJ
STANDARD SOFT
BLANK JAW
STANDARD SOFT JAW

95



HJ
STANDARD
HARDENED JAW
STANDARD HARDENED JAW

99



T-NUT
T-NUT
T-NUT

101



FL
CHUCK ADAPTORS
ADAPTOR

102



CT/CT-S
COOLANT COLLECTOR
WITH STROKE
CONTROL
COOLANT COLLECTOR

103



CT-SB/CT-SBS
COOLANT COLLECTOR
WITH STROKE CONTROL
COOLANT COLLECTOR

104



FV
STATIONARY
CYLINDER LOCK VALVE
FOR AIR STATIONARY CHUCK
ACCESSORIES

105

DRAW TUBE
THE CALCULATION OF DRAW TUBE
LENGTH
DRAW TUBE

106

DRAW BAR
THE CALCULATION OF DRAW BAR
LENGTH
DRAW BAR

107

**FREE DOWNLOAD
MASTER AUTOGRIP PRODUCT INFORMATION!**



Website



YouTube



Linkin



twitter



You can download the outline drawing (in pdf or dwg format) and 3D step at AUTOGRIP WEB.

3H-2/3H-2A LARGE THRU-HOLE POWER CHUCK

3-Jaw / Thru-Hole



- WEDGE-HOOK type 3-jaw with the extra large through-hole.
- Matching surfaces of all parts hardened, ground and lubricated directly.
- High rigidity and high clamping accuracy.
- J is the hole diameter of blank draw nut.
If not notified, AUTOGRIP will adopt the K Default as K value.
K is the maximum thread specification and it could be customize.

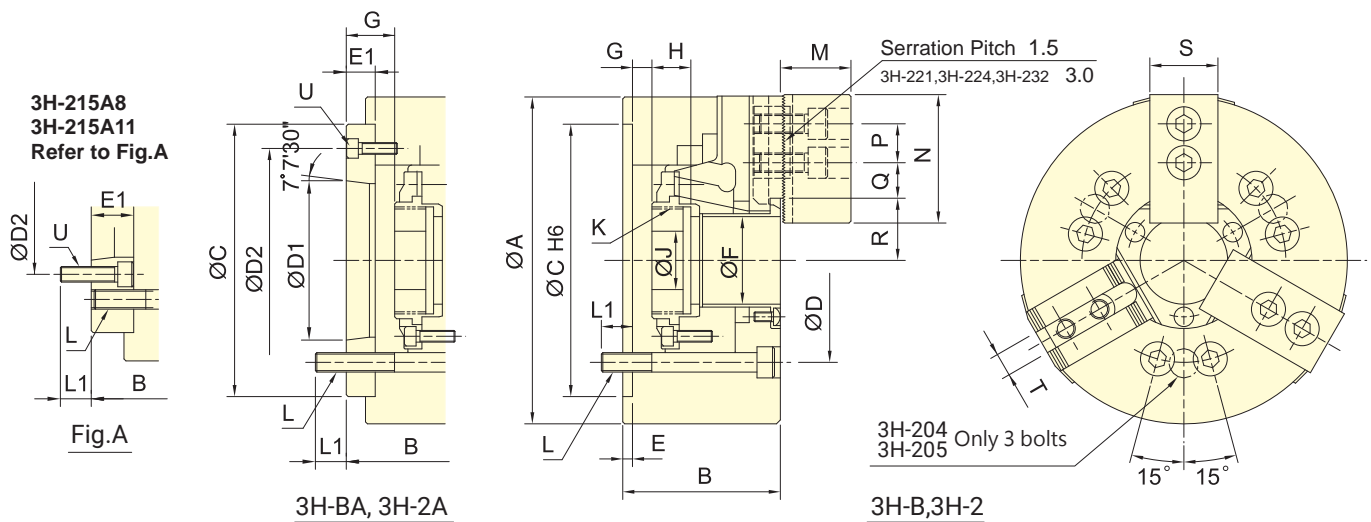

Subject to technical changes

SPECIFICATIONS

Model	Plunger stroke mm	Jawstroke (Dia.) mm	Chucking Dia. Max. mm	Chucking Dia. Min. mm	Max. D.B. pull kN (kgf)	Max. Clamping force kN (kgf)	Max. speed min ⁻¹ (r.p.m.)	Moment of inertia kg · m ²	Weight		Matching cyl.	Max. pressure MPa (kgf/cm ²)	
									kg	kg			
3H-204	A4	13	5.5	113	7	13.7(1400)	36.0(3670)	8000	0.012	4.22	5.34	TK-A528	2.0(20)
3H-205	A4	13	5.5	138	10	17.2(1750)	48(4890)	7000	0.02	6.3	7.1	TK-A533	2.5(25)
3H-206	A5	14	6	170	13	23.3(2375)	66.8(6810)	6000	0.06	13.1	14.9	TK-A646	2.5(25)
3H-208	A6	18	7.6	210	17	31.9(3250)	107(10900)	5000	0.15	21.8	23.4	TK-A853	2.6(26)
3H-210	A8	21	8.9	260	37	49.1(5010)	152(15500)	4500	0.32	37.5	43	TK-A1075	3.2(32)
3H-212	A11	25	10.6	315	43	58.8(6000)	157(16010)	3700	0.74	58.6	64.7	TK-A1512	1.9(19)
3H-215	A8	25	10.6	405	49	71(7240)	180(18350)	2500	2.8	127	149	TK-2114	2.1(21)
3H-215	A11	25	10.6	405	49	71(7240)	180(18350)	2500	2.8	127	143.3	TK-2114	2.1(21)
3H-215	A15	25	10.6	405	49	71(7240)	180(18350)	2500	2.8	127	135.6	TK-2114	2.1(21)
3H-18B	A15	23	10.6	456	79	71(7240)	180(18350)	2000	4.8	162.4	173.4	TK-2416	1.9(19)
3H-221	A15	28	12.9	530	105	90(9175)	234(23860)	1800	7.5	223	234	TK-2416	2.4(24)
3H-224	A20	28	12.9	610	135	100(10200)	240(24500)	1500	15.8	270	284	TK-2820	2.1(21)
3H-232	A20	34	18	800	205	100(10200)	240(24500)	1200	47	546	560	TK-2820	2.1(21)

1. The dimensions and the specifications of 3H-2A, 3H-BA type are in red data.

DIMENSIONS

Model	A	B		C	D	D1	D2	E	E1	F	G max.		G min.		H	J	
3H-204	A4	113	59	83	85	70.6	63.51	82.6	4	28	32	3.5	31.5	-9.5	18.5	17.5	12
3H-205	A4	138	60	71	110	82.6	63.51	96	4	15	39	1	16	-12	3	20	12
3H-206	A5	170	81	91	140	104.8	82.56	116	5	15	53	13	28	-1	14	17.5	20
3H-208	A6	210	91	103	170	133.4	106.38	150	5	17	66	16.5	33.5	-1.5	15.5	20	30
3H-210	A8	260	102	115	220	171.4	139.72	190	5	18	86	10.5	28.5	-10.5	7.5	25	45
3H-212	A11	315	110	126	300	235	196.87	260	6	22	106	10	32	-15	7	28	50
3H-215	A8	405	132	159	380	330.2	139.72	171.4	6	33	145	11	44	-14	19	39	60
3H-215	A11	405	132	166	380	330.2	196.87	235	6	40	145	11	51	-14	26	39	60
3H-215	A15	405	132	153	380	330.2	285.78	330.2	6	27	145	11	38	-14	13	39	60
3H-18B	A15	456	145	166	380	330.2	285.78	330.2	6	27	165	18	45	-5	22	40	60
3H-221	A15	530	140	161	380	330.2	285.78	330.2	6	27	180	15	42	-13	14	40	80
3H-224	A20	610	145	166	520	463.6	412.78	463.6	6	27	210	15	42	-13	14	41	80
3H-232	A20	800	150	170	520	463.6	412.78	463.6	6	27	275	24	51	-10	17	42	100

Model	K max.	K Default		L	L1	M	N	P	Q max.	Q min.	R max.	R min.	S	T	U			
3H-204	A4	M38x1.5	M32x1.5	3~M10	16.0	15	24	52	14	12.75	6.75	25	22.25	23	10	3~M10		
3H-205	A4	M45x1.5	M40x1.5	3~M10	14.5	14.5	31	62	14	20.25	6.75	29.5	26.8	25	10	3~M6		
3H-206	A5	M60x2	M55x2	6~M10	16.0	16	37	73	20	21.25	9.25	36	33	31	12	3~M6		
3H-208	A6	M75x2	M60x2	6~M12	17.0	15	38	95	25	23.7	10.2	45.7	41.9	35	14	3~M6		
3H-210	A8	M95x2	M85x2	6~M16	20.0	22	43	110	30	32.2	12.7	56.5	52.05	40	16	3~M8		
3H-212	A11	M115x2	M115x2	6~M20	30.0	28	51	130	30	44.75	14.75	67.8	62.5	50	21	3~M10		
3H-215	A8	M155x3	M115x2	M155x3	M100x2	6~M24	36.0	24	63	165	43	49.75	19.75	90	84.7	62	25.5	6~M16
3H-215	A11	M155x3	M155x3	6~M24	36.0	31	63	165	43	49.75	19.75	90	84.7	62	25.5	6~M20		
3H-215	A15	M155x3	M155x3	6~M24	36.0	34	63	165	43	49.75	19.75	90	84.7	62	25.5	3~M12		
3H-18B	A15	M175x3	M175x3	6~M24	38.0	36	63	165	43	64	20.5	102	96.7	62	25.5	3~M12		
3H-221	A15	M190x3	M190x3	6~M24	33.0	36	73	180	60	69.5	24.5	113.5	107.1	65	25	3~M12		
3H-224	A20	M225x3	M225x3	6~M24	35.0	33	73	180	60	93.5	24.5	128	121.5	65	25	3~M12		
3H-232	A20	M295x3	M295x3	6~M24	36.0	34	73	180	60	150.5	24.5	166	157	65	25	3~M12		

// The 3H-2 series are power chucks with extra large thru-hole design. The rotary cylinders are recommended based on power chucks that from 4"-10" are common used in the industry. If you find that you need different bore size or installation interface, please just contact us. We have many standard and customized rotary cylinders for option and meet your needs. Please contact AUTOGRIP for more detailed information. Thanks.

1. The dimensions and the specifications of 3H-2A,3H-BA type are in red data.



- WEDGE-HOOK type 3-jaw with the large through-hole.
- Matching surfaces of all parts hardened, ground and lubricated directly.
- High rigidity and high clamping accuracy.
- J is the hole diameter of blank draw nut.
If not notified, AUTOGRIP will adopt the K Default as K value.
K is the maximum thread specification and it could be customize.

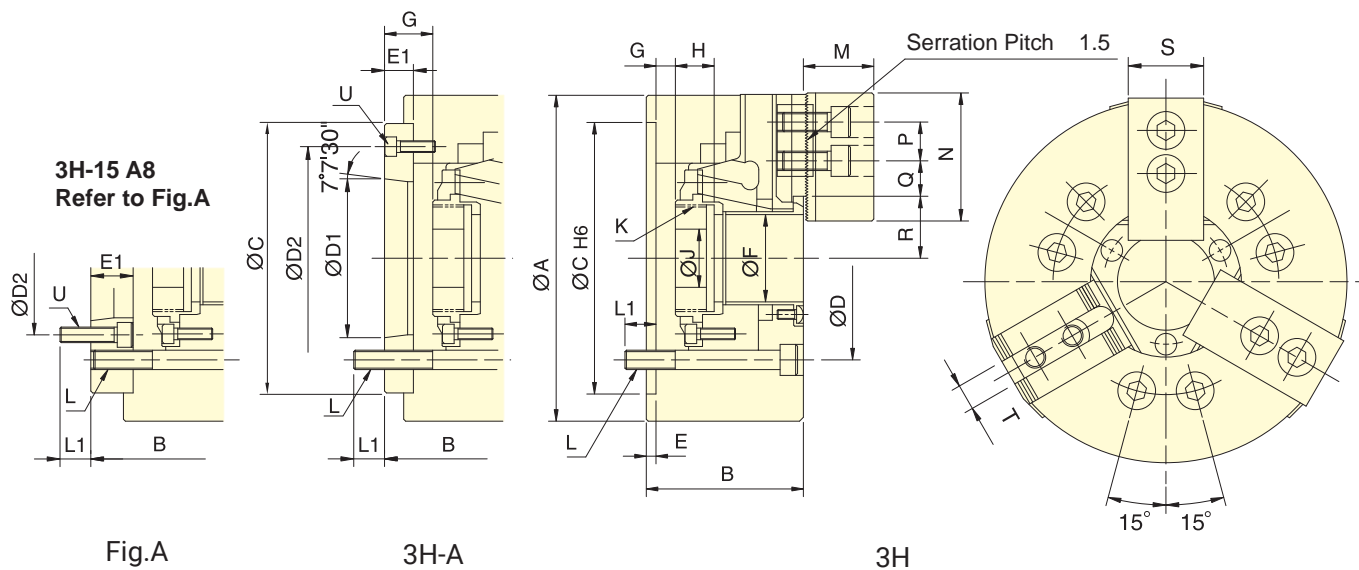

Subject to technical changes

SPECIFICATIONS

Model	Plunger stroke	Jaw stroke (Dia.)	Chuck-ing Dia. Max.	Chuck-ing Dia. Min.	Max. D.B. pull	Max. Clamping force	Max. speed	Moment of inertia	Weight	Matching cyl.	Max. pressure		
	mm	mm	mm	mm	kN (kgf)	kN (kgf)	min ⁻¹ (r.p.m.)	kg · m ²	kg			MPa (kgf/cm ²)	
3H-12	A8	25	10.6	304	34	54.9(5600)	143.7(14650)	3300	0.77	56.6	59.3	TK-A1291	2.5(25)
3H-15	A8	25	10.6	381	20	71(7250)	179.8(18350)	2500	2.28	120	134	TK-A1512	2.3(23)
3H-15	A11	25	10.6	381	20	71(7250)	179.8(18350)	2500	2.39	120	127	TK-A1512	2.3(23)
3H-18	A11	23	10.6	450	50	71(7250)	179.8(18350)	2000	4.78	164	178	TK-A1512	2.3(23)

DIMENSIONS

Model	A	B	C	D	D1	D2	E	E1	F	G max.	G min.	H	J				
3H-12	A8	304	110	122	220	171.4	139.72	190	6	18	91	10	28	-15	3	28	50
3H-15	A8	381	132	159	300	235	139.72	171.4	6	33	120	11	44	-14	19	39	60
3H-15	A11	381	132	148	300	235	196.87	260	6	22	120	11	33	-14	8	39	60
3H-18	A11	450	133	149	300	235	196.87	260	6	22	120	11	33	-12	10	39	60

Model	K max.	K Default	L	L1	M	N	P	Q max.	Q min.	R max.	R min.	S	T	U				
3H-12	A8	M100x2	M100x2	6~M16	23	25	51.3	130	30	44.75	14.75	61.3	56	50	21	3~M8		
3H-15	A8	M130x2	M115x2	M130x2	M100x2	6~M20	30	24	63	165	43	49.75	19.75	77.5	72.2	62	25.5 or 22	6~M16
3H-15	A11	M130x2	M130x2	M130x2	M130x2	6~M20	30	28	63	165	43	49.75	19.75	77.5	72.2	62	25.5 or 22	3~M10
3H-18	A11	M130x2	M130x2	M130x2	M130x2	6~M20	30	28	63	165	43	83.5	20.5	80	74.7	62	25.5 or 22	3~M10

1. The dimensions and the specifications of 3H-A type are in red data.



- WEDGE-HOOK type 2-jaw with the large through-hole.
- Matching surfaces of all parts hardened, ground and lubricated directly.
- High rigidity and high clamping accuracy.
- J is the hole diameter of blank draw nut.
If not notified, AUTOGRIP will adopt the K Default as K value.
K is the maximum thread specification and it could be customize.

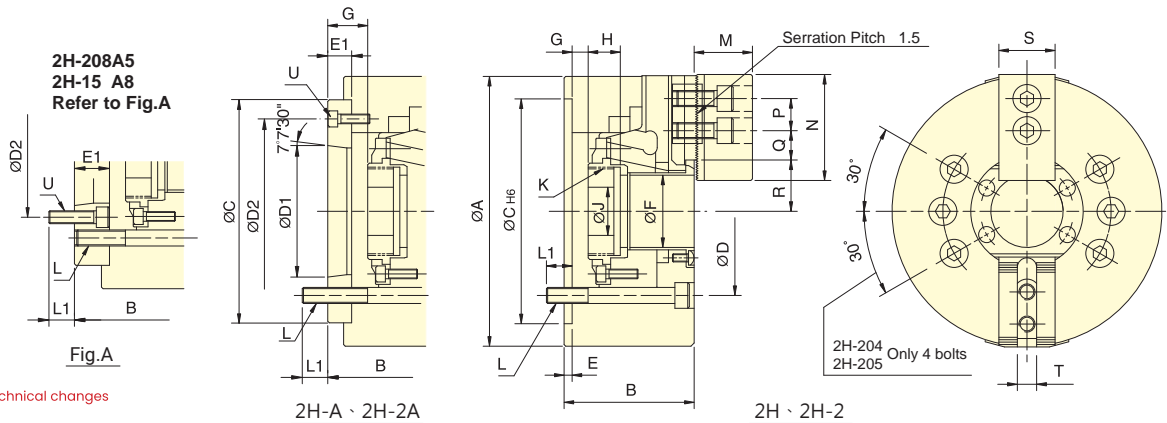

Subject to technical changes

SPECIFICATIONS

Model	Plunger stroke	Jaw stroke (Dia.)	Chucking Dia. Max.	Chucking Dia. Min.	Max. D.B. pull	Max. Clamping force	Max. speed	Moment of inertia	Weight		Matching cyl.	Max. pressure	
									mm	mm			kg
2H-204	A4	13	5.5	113	7	9.2(940)	19.4(1980)	8000	0.012	4.2	4.8	TK-A528	1.3(13)
2H-205	A4	13	5.5	138	10	11.4(1167)	32(3260)	7000	0.02	6.8	7.6	TK-A533	1.6(16)
2H-206	A5	14	6	170	13	15.5(1580)	44.4(4530)	6000	0.06	13.1	14.9	TK-A646	1.6(16)
2H-208	A5	18	7.6	210	17	23.1(2360)	57.3(5840)	5000	0.17	21.3	24.2	TK-A853	1.8(18)
2H-208	A6	18	7.6	210	17	23.1(2360)	57.3(5840)	5000	0.17	21.3	22.4	TK-A853	1.8(18)
2H-210	A8	21	8.9	260	37	32.9(3355)	101.9(10385)	4500	0.31	33.5	36.2	TK-A1075	2.2(22)
2H-12	A8	23	10.6	304	34	36.7(3740)	95.8(9780)	3300	0.70	59.7	62.7	TK-A1291	1.7(17)
2H-15	A8	23	10.6	381	50	46.9(4790)	119.6(12200)	2500	2.42	115	129	TK-A1512	1.5(15)
2H-15	All	23	10.6	381	50	46.9(4790)	119.6(12200)	2500	2.34	115	122	TK-A1512	1.5(15)

DIMENSIONS

Model	A	B	C	D	D1	D2	E	E1	F	G max.	G min.	H	J				
2H-204	A4	113	59	83	85	70.6	63.51	82.6	4	28	32	3.5	31.5	-9.5	18.5	17.5	12
2H-205	A4	138	60	71	110	82.6	63.51	96	4	15	39	1	16	-12	3	20	12
2H-206	A5	170	81	91	140	104.8	82.56	116	5	15	53	13	28	-1	14	17.5	20
2H-208	A5	210	91	109	170	133.4	82.56	104.8	5	23	66	16.5	39.5	-1.5	21.5	20	30
2H-208	A6	210	91	103	170	133.4	106.38	150	5	17	66	16.5	33.5	-1.5	15.5	20	30
2H-210	A8	260	102	115	220	171.4	139.72	190	5	18	86	10.5	28.5	-10.5	7.5	25	45
2H-12	A8	304	110	122	220	171.4	139.72	190	6	18	91	8	26	-15	3	28	50
2H-15	A8	381	133	160	300	235	139.72	171.4	6	33	120	11	44	-12	21	39	60
2H-15	All	381	133	149	300	235	196.87	260	6	22	120	11	33	-12	10	39	60

Model	K max.	K Default	L	L1	M	N	P	Q max.	Q min.	R max.	R min.	S	T	U				
2H-204	A4	M38x1.5	M32x1.5	4~M10	16	15	24	52	14	12.75	6.75	25	22.25	23	10	3~M10		
2H-205	A4	M45x1.5	M40x1.5	4~M10	14.5	14.5	31	62	14	20.25	6.75	29.5	26.75	25	10	3~M6		
2H-206	A5	M60x2	M55x2	6~M10	16	16	37	73	20	22.75	9.25	36	33	31	12	3~M6		
2H-208	A5	M75x2	M60x2	6~M12	17	18	38	95	25	23.7	10.2	45.7	41.9	35	14	6~M10		
2H-208	A6	M75x2	M60x2	6~M12	17	15	38	95	25	23.7	10.2	45.7	41.9	35	14	3~M6		
2H-210	A8	M95x2	M85x2	6~M16	20	22	43	110	30	32.2	12.7	56.5	52.05	40	16	3~M8		
2H-12	A8	M100x2	M100x2	6~M16	23	25	51	130	30	45.8	15.8	61.3	56	50	21	3~M8		
2H-15	A8	M130x2	M115x2	M130x2	M100x2	6~M20	30	24	63	165	43	47.3	18.2	80	74.7	62	25.5 or 22	6~M16
2H-15	All	M130x2	M130x2	6~M20	30	28	63	165	43	47.3	18.2	80	74.7	62	25.5 or 22	3~M10		

1. The dimensions and the specifications of 2H-A, 2H-2A type are in red data.

4H/4H-A THRU-HOLE POWER CHUCK

4-Jaw / Thru-Hole

POWER CHUCKS



- WEDGE-HOOK type 4-jaw with the large through-hole.
- Matching surfaces of all parts hardened, ground and lubricated directly.
- High rigidity and high clamping accuracy.
- J is the hole diameter of blank draw nut.
If not notified, AUTOGRIP will adopt the K Default as K value.
K is the maximum thread specification and it could be customize.

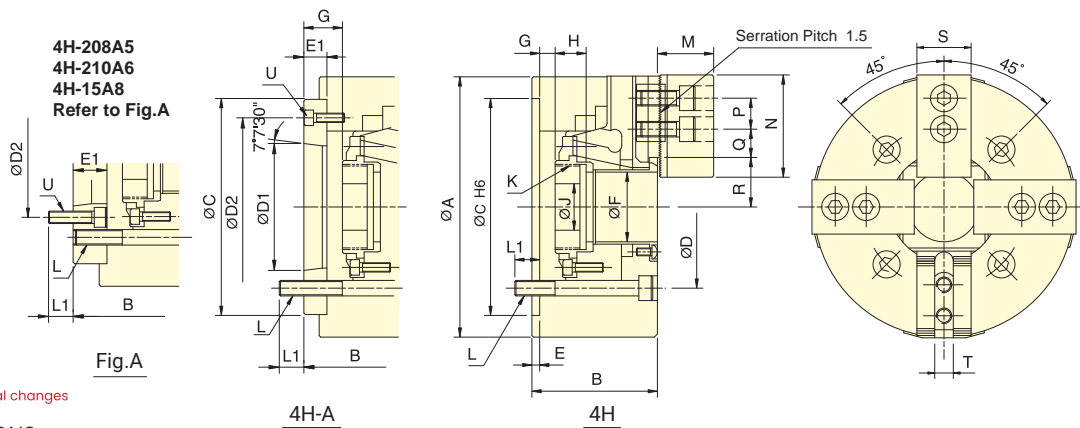

Subject to technical changes

SPECIFICATIONS

Model	Plunger stroke	Jawstroke (Dia.)	Chucking Dia. Max.	Chucking Dia. Min.	Max. D.B. pull	Max. Clamping force	Max. speed	Moment of inertia	Weight		Matching cyl.	Max. pressure	
									mm	mm			kg
4H-206	A5	14	6.0	170	13	23.2(2375)	66.7(6810)	5000	0.06	12.5	16.7	TK-C646	2.5(25)
4H-208	A5	18	7.6	210	17	34.3(3500)	85.8(8750)	4200	0.19	23.5	25.4	TK-A853	2.8(28)
4H-208	A6	18	7.6	210	17	34.3(3500)	85.8(8750)	4200	0.19	23.5	24.3	TK-A853	2.8(28)
4H-210	A6	21	8.9	260	37	49.1(5010)	110.7(11300)	3800	0.4	38.7	44	TK-A1075	3.2(32)
4H-210	A8	21	8.9	260	37	49.1(5010)	110.7(11300)	3800	0.4	38.7	42.3	TK-A1075	3.2(32)
4H-12	A8	25	10.6	304	34	54.9(5600)	143.6(14650)	2700	0.77	62	65.7	TK-A1291	2.5(25)
4H-15	A8	23	10.6	381	50	71(7250)	179.8(18350)	2000	2.5	123.7	137.7	TK-A1512	2.3(23)
4H-15	All	23	10.6	381	50	71(7250)	179.8(18350)	2000	2.42	123.7	130.7	TK-A1512	2.3(23)
4H-18	All	23	10.6	450	50	71(7250)	179.8(18350)	1700	4.85	170	184	TK-A1512	2.3(23)

DIMENSIONS

Model	A	B	C	D	D1	D2	E	EI	F	G max.	G min.	H	J				
4H-206	A5	170	81	91	140	104.8	82.56	116	5	15	53	13	28	-1	14	17.5	20
4H-208	A5	210	91	109	170	133.4	82.56	104.8	5	23	66	16.5	39.5	-1.5	21.5	20.5	30
4H-208	A6	210	91	103	170	133.4	106.38	150	5	17	66	16.5	33.5	-1.5	15.5	20.5	30
4H-210	A6	260	102	122	220	171.4	106.38	133.4	5	25	86	10.5	35.5	-10.5	14.5	25	45
4H-210	A8	260	102	115	220	171.4	139.72	190	5	18	86	10.5	28.5	-10.5	7.5	25	45
4H-12	A8	304	110	122	220	171.4	139.72	190	6	18	91	10	28	-15	3	28	50
4H-15	A8	381	133	160	300	235	139.72	171.4	6	33	120	11	44	-12	21	39	60
4H-15	All	381	133	149	300	235	196.87	260	6	22	120	11	33	-12	10	39	60
4H-18	All	450	133	149	300	235	196.87	260	6	22	120	11	33	-12	10	39	60

Model	K max.	K Default	L	L1	M	N	P	Qmax.	Q min.	R max.	R min.	S	T	U				
4H-206	A5	M60x2	M55x2	4~M10	16	16	37	73	20	21.25	9.25	36	33	31	12	3~M6		
4H-208	A5	M75x2	M60x2	4~M12	17	18	38	95	25	23.7	10.2	45.7	41.9	35	14	6~M10		
4H-208	A6	M75x2	M60x2	4~M12	17	15	38	95	25	23.7	10.2	45.7	41.9	35	14	3~M6		
4H-210	A6	M95x2	M85x2	4~M16	20	18	43	110	30	32.2	12.7	56.5	52.05	40	16	6~M12		
4H-210	A8	M95x2	M85x2	4~M16	20	22	43	110	30	32.2	12.7	56.5	52.05	40	16	3~M8		
4H-12	A8	M100x2	M100x2	4~M16	23	25	51.3	130	30	44.75	14.75	61.3	56	50	21	3~M8		
4H-15	A8	M130x2	M115x2	M130x2	M100x2	4~M20	30	24	63	165	43	47.5	20.5	80	74.7	62	25.5 or 22	6~M16
4H-15	All	M130x2	M130x2	4~M20	30	28	63	165	43	47.5	20.5	80	74.7	62	25.5 or 22	3~M10		
4H-18	All	M130x2	M130x2	4~M20	30	28	63	165	43	83.5	20.5	80	74.7	62	25.5 or 22	3~M10		

1. The dimensions and the specifications of 4H-A type are in red data.



- WEDGE-HOOK type 3-jaw mini power chuck.
- Matching surfaces of all parts hardened, ground and lubricated directly.
- Suitable for bench lathe.

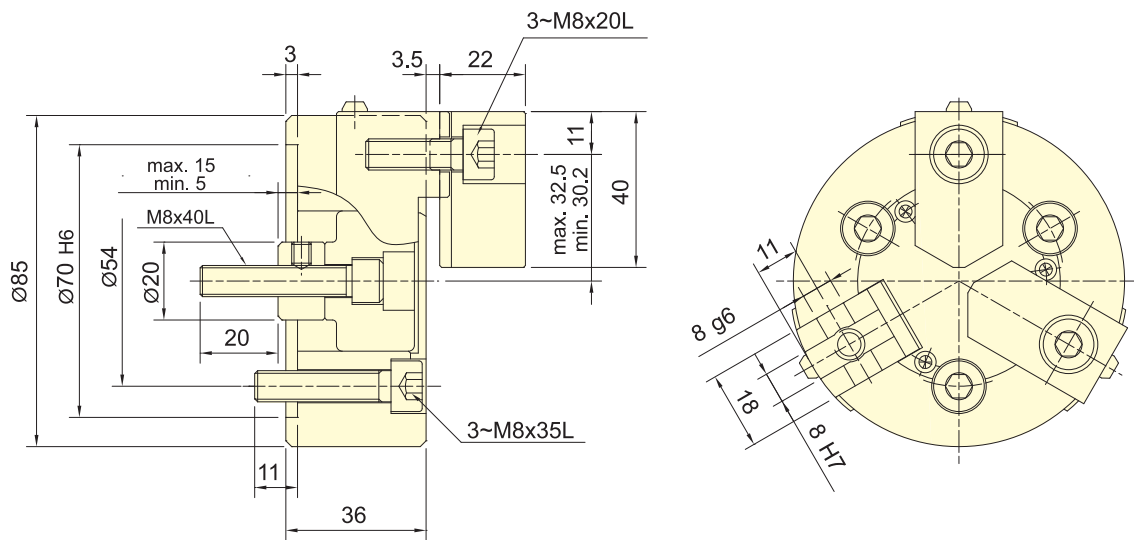

Subject to technical changes

SPECIFICATIONS

Model	Plunger stroke	Jaw stroke (Dia.)	Chucking Dia. Max.	Chucking Dia. Min.	Max. D.B. pull	Max. Clamping force	Max. speed	Moment of inertia	Weight	Matching cyl.	Max. pressure MPa(kgf/cm ²)
	mm	mm	mm	mm	kN (kgf)	kN (kgf)	min ⁻¹ (r.p.m.)	kg · m ²	kg		
3P-03	10	4.6	85	3	4.5(460)	11.3(1150)	7000	0.004	1.8	RK-75	1.2(12.4)

Standard Soft Jaw For 3P-03 Power Chuck
SJ-K03

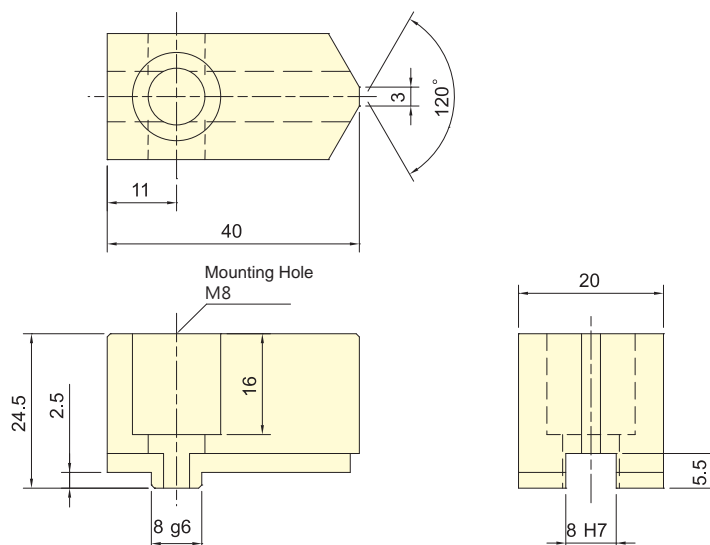



- WEDGE-HOOK type 3-jaw power chuck.
- Matching surfaces of all parts hardened, ground and lubricated directly.
- High rigidity and high clamping accuracy.

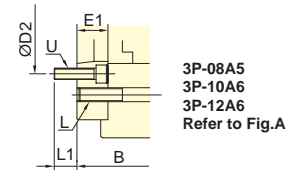
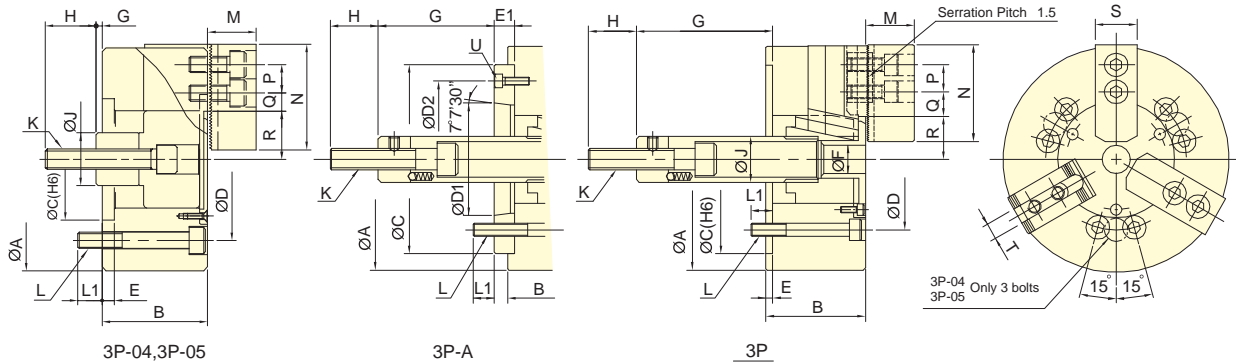

Fig.A



Subject to technical changes

SPECIFICATIONS

Model	Plunger stroke mm	Jawstroke (Dia.) mm	Chucking Dia.Max. mm	Chucking Dia. Min. mm	Max. D.B. pull kN (kgf)	Max. Clamping force kN (kgf)	Max. speed min ⁻¹ (r.p.m.)	Moment of inertia kg · m ²	Weight kg	Matching cyl.	Max. pressure MPa (kgf/cm ²)	
3P-04	15	6.9	110	5	8.1(830)	22.5(2300)	6000	0.01	4.1	-	RK-75(N) RA-130 2.2(22) 0.6(6)	
3P-05	15	6.9	135	14	8.1(830)	25(2550)	5500	0.02	6.2	-	RK-75(N) RA-130 2.2(22) 0.6(6)	
3P-06	A5	20	9.2	165	16	17.9(1830)	52.4(5350)	5250	0.05	13	14	RK-100(N) RA-170 2.6(26) 0.6(6)
3P-08	A5	21	9.7	210	21	25(2550)	74.5(7600)	4750	0.14	24	28	RK-125(N) RA-220 2.3(23) 0.5(5)
3P-08	A6	21	9.7	210	21	25(2550)	74.5(7600)	4750	0.14	24	27	RK-125(N) RA-220 2.3(23) 0.5(5)
3P-10	A6	25	8.8	254	24	28.9(2950)	107.8(11000)	4000	0.3	35	42	RK-125(N) RA-220 2.6(26) 0.6(6)
3P-10	A8	25	8.8	254	24	28.9(2950)	107.8(11000)	4000	0.3	35	40	RK-125(N) RA-220 2.6(26) 0.6(6)
3P-12	A6	30	10.5	304	24	41(4180)	155.8(15900)	3360	0.73	59	65	RK-150(N) RA-270 2.6(26) 0.8(8)
3P-12	A8	30	10.5	304	24	41(4180)	155.8(15900)	3360	0.73	59	63	RK-150(N) RA-270 2.6(26) 0.8(8)

DIMENSIONS

Model	A	B	C	D	D1	D2	E	E1	F	G max.	G min.	H	J			
3P-04	110	52	-	60	80	-	6	-	-	18	-	25	26			
3P-05	135	55	-	80	100	-	7	-	-	9	-6	35	28			
3P-06	A5	165	84	140	104.8	82.56	116	5	15	21	102.6	87.6	82.6	67.6	35	34
3P-08	A5	210	103	170	133.4	82.56	104.8	5	23	25	127	104	106	83	36	38
3P-08	A6	210	97	170	133.4	106.38	150	5	17	25	127	110	106	89	36	38
3P-10	A6	254	109	220	171.4	106.38	133.4	5	25	34	158	133	133	108	36	45
3P-10	A8	254	102	220	171.4	139.72	190	5	18	34	158	140	133	115	36	45
3P-12	A6	304	125	220	171.4	106.38	133.4	6	25	34	163	138	133	108	36	50
3P-12	A8	304	118	220	171.4	139.72	190	6	18	34	163	145	133	115	36	50

Model	K	L	L1	M	N	P	Q max.	Q min.	R max.	R min.	S	T	U
3P-04	M10x1.5	3~M8	12	-	24	52	11.2	6.7	23.6	20.15	23	10	-
3P-05	M12x1.75	3~M8	14	-	31	62	15.7	5.2	30.4	26.95	25	10	-
3P-06	A5	M16x2	6~M10	14	14	37	18.25	9.25	38.25	33.65	31	12	3~M6
3P-08	A5	M20x2.5	6~M12	20	17	38	25.25	11.75	46.3	41.45	35	14	6~M10
3P-08	A6	M20x2.5	6~M12	20	18	38	25.25	11.75	46.3	41.45	35	14	3~M6
3P-10	A6	M20x2.5	6~M16	18	18	43	35.25	12.75	51.1	46.7	40	16	6~M12
3P-10	A8	M20x2.5	6~M16	18	25	43	35.25	12.75	51.1	46.7	40	16	3~M8
3P-12	A6	M20x2.5	6~M16	18	18	51	48.75	12.75	61	55.75	50	18 or 21	6~M12
3P-12	A8	M20x2.5	6~M16	18	25	51	48.75	12.75	61	55.75	50	18 or 21	3~M8

1. The dimensions and the specifications of 3P-A type are in red data.



- WEDGE-HOOK type 3-jaw power chuck.
- Matching surfaces of all parts hardened, ground and lubricated directly.
- High rigidity and high clamping accuracy.

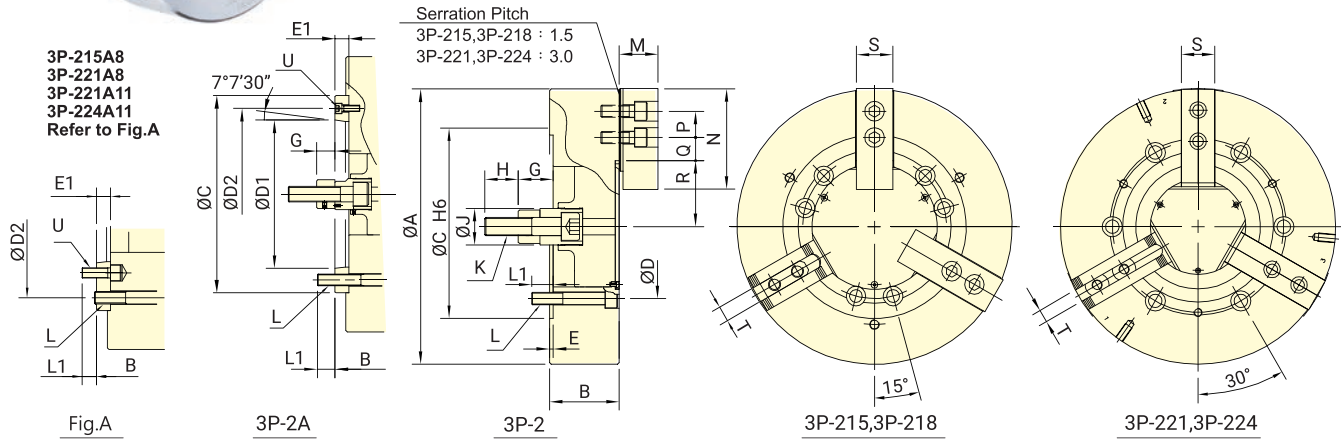

Subject to technical changes

SPECIFICATIONS

Model	Plunger stroke	Jaw stroke (Dia.)	Chucking Dia. Max.	Chucking Dia. Min.	Max. D.B. pull	Max. Clamping force	Max. speed	Moment of inertia	Weight		Matching cyl.	Max. pressure	
									mm	mm			mm
3P-215	A8	35	16	381	50	82(8360)	249(25390)	3000	1.8	109.9	122.4	RH-200 or RK-200(N)	2.8(28)
3P-215	A11	35	16	381	50	82(8360)	249(25390)	3000	1.8	109.9	116	RH-200 or RK-200(N)	2.8(28)
3P-218	A11	35	16	450	60	82(8360)	249(25400)	2800	2.32	124	130	RH-200 or RK-200(N)	2.8(28)
3P-221	A8	35	16	530	59	82(8360)	272.6(27800)	1900	4.9	177	200	RH-200 or RK-200(N)	2.8(28)
3P-221	A11	35	16	530	59	82(8360)	272.6(27800)	1900	4.9	177	194	RH-200 or RK-200(N)	2.8(28)
3P-224	A11	35	16	610	152	82(8360)	272.6(27800)	1750	7	230	246.28	RH-200 or RK-200(N)	2.8(28)
3P-224	A15	35	16	610	152	82(8360)	272.6(27800)	1750	7	230	238.6	RH-200 or RK-200(N)	2.8(28)

DIMENSIONS

Model	A	B	C	D	D1	D2	E	E1	G max.	G min.	H	J	K				
3P-215	A8	381	114	141	300	235	139.72	171.4	6	33	104	71	69	36	55	60	M30x3.5
3P-215	A11	381	114	130	300	235	196.87	260	6	22	104	82	69	47	55	60	M30x3.5
3P-218	A11	450	114	130	300	235	196.87	260	6	22	92	70	57	35	55	60	M30x3.5
3P-221	A8	530	125	152	380	330.2	139.72	171.4	6	33	97	64	62	29	55	60	M30x3.5
3P-221	A11	530	125	146	380	330.2	196.87	235	6	27	97	70	62	35	55	60	M30x3.5
3P-224	A11	610	125	146	380	330.2	196.87	235	6	27	97	70	62	35	55	60	M30x3.5
3P-224	A15	610	125	146	380	330.2	285.78	330.2	6	27	97	70	62	35	55	60	M30x3.5

Model	L	L1	M	N	P	Q max.	Q min.	R max.	R min.	S	T	U		
3P-215	A8	6~M20	30	24	63.3	165	43	51.25	18.25	77.5	69.5	62	25.5	6~M16
3P-215	A11	6~M20	30	33	63.3	165	43	51.25	18.25	77.5	69.5	62	25.5	3~M10
3P-218	A11	6~M20	35	33	63.3	165	43	52.75	18.25	108	100	62	25.5	3~M10
3P-221	A8	6~M24	31	24	71	180	60	96.5	24.5	86	78	65	25	6~M16
3P-221	A11	6~M24	31	28	71	180	60	96.5	24.5	86	78	65	25	6~M20
3P-224	A11	6~M24	31	28	71	180	60	96.5	24.5	125	117	65	25	6~M20
3P-224	A15	6~M24	31	34	71	180	60	96.5	24.5	125	117	65	25	3~M12

1. 紅色數據為 3P-A 型之寸法 (The dimensions and the specifications of 3P-A type are in red data.)



- WEDGE-HOOK type 2-jaw power chuck.
- Matching surfaces of all parts hardened, ground and lubricated directly.
- High rigidity and high clamping accuracy.

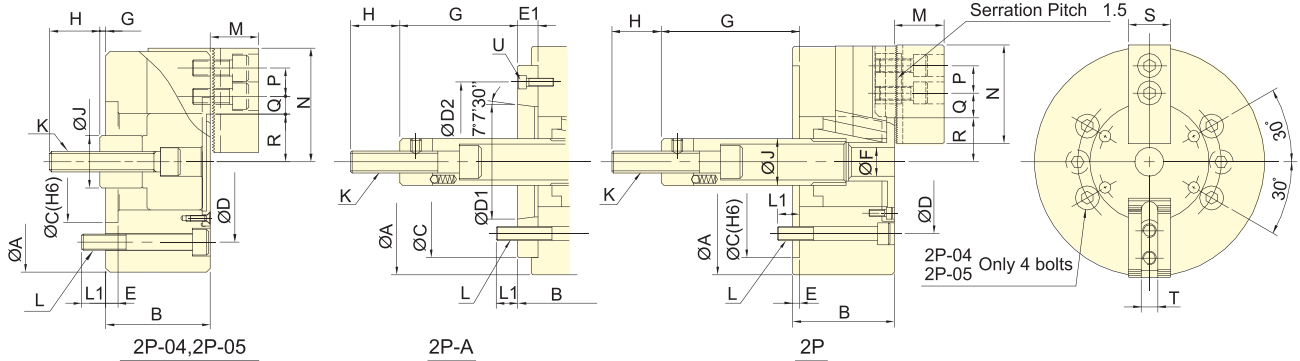
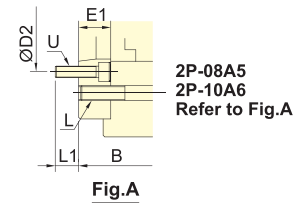

Subject to technical changes

SPECIFICATIONS

Model	Plunger stroke	Jaw stroke (Dia.)	Chucking Dia. Max.	Chucking Dia. Min.	Max. D.B. pull	Max. Clamping force	Max. speed	Moment of inertia	Weight	Matching cyl.	Max. pressure	
	mm	mm	mm	mm	kN (kgf)	kN (kgf)	min ⁻¹ (r.p.m.)	kg · m ²	kg		MPa (kgf/cm ²)	
2P-04	15	6.9	110	5	5.3(540)	14.7(1500)	6000	0.01	3.8	-	1.5(15) 0.4(4)	
2P-05	15	6.9	135	14	5.3(540)	16.7(1700)	5500	0.02	5.8	-	1.5(15) 0.4(4)	
2P-06	A5	20	9.2	165	14	12(1220)	35(3570)	5250	0.04	12	13	1.7(17) 0.4(4)
2P-08	A5	21	9.7	210	17	16.5(1680)	50(5100)	4750	0.13	22	26	1.5(15) 0.4(4)
2P-08	A6	21	9.7	210	17	16.5(1680)	50(5100)	4750	0.13	22	25	1.5(15) 0.4(4)
2P-10	A6	25	8.8	254	22	19.4(1980)	71.5(7300)	4000	0.29	33	42	1.8(18) 0.4(4)
2P-10	A8	25	8.8	254	22	19.4(1980)	71.5(7300)	4000	0.29	33	40	1.8(18) 0.4(4)
2P-12	A8	30	10.5	304	22	27.4(2800)	103.9(10600)	3360	0.70	57	61	1.7(17)
2P-15	All	35	16	381	50	54.9(5600)	164.6(16800)	3000	1.70	96	103	1.9(19)

DIMENSIONS

Model	A	B	C	D	D1	D2	E	E1	F	G max.	G min.	H	J				
2P-04	110	52	-	60	80	-	6	-	-	18	-	25	26				
2P-05	135	55	-	80	100	-	7	-	-	9	-	35	28				
2P-06	A5	165	74	84	140	104.8	82.56	116	5	15	21	102.6	87.6	82.6	67.6	35	34
2P-08	A5	210	85	103	170	133.4	82.56	104.8	5	23	25	127	104	106	83	36	38
2P-08	A6	210	85	97	170	133.4	106.38	150	5	17	25	127	110	106	89	36	38
2P-10	A6	254	89	109	220	171.4	106.38	133.4	5	25	34	158	133	133	108	36	45
2P-10	A8	254	89	102	220	171.4	139.72	190	5	18	34	158	140	133	115	36	45
2P-12	A8	304	106	118	220	171.4	139.72	190	6	18	34	163	145	133	115	36	50
2P-15	All	381	114	130	300	235	196.87	260	6	22	-	104	82	69	47	55	60

Model	K	L	LI	M	N	P	Q max.	Q min.	R max.	R min.	S	T	U		
2P-04	M10x1.5	4~M8	12	-	24	52	14	11.3	8.3	23.3	20.15	23	10	-	
2P-05	M12x1.75	4~M8	14	-	31	62	14	13.5	6	30.4	26.95	25	10	-	
2P-06	A5	M16x2	6~M10	14	14	37	73	20	18.25	9.25	38.25	33.65	31	12	3~M6
2P-08	A5	M20x2.5	6~M12	20	17	38	95	25	22.3	11.8	46.3	41.45	35	14	6~M10
2P-08	A6	M20x2.5	6~M12	20	18	38	95	25	22.3	11.8	46.3	41.45	35	14	3~M6
2P-10	A6	M20x2.5	6~M16	18	18	43	110	30	30.8	11.3	51.1	46.7	40	16	6~M12
2P-10	A8	M20x2.5	6~M16	18	25	43	110	30	30.8	11.3	51.1	46.7	40	16	6~M8
2P-12	A8	M20x2.5	6~M16	18	25	51	130	30	48.5	12.5	-	-	50	18 or 21	6~M8
2P-15	All	M30x3.5	6~M20	30	33	63	165	43	48.8	23.3	77.5	69.5	62	25.5	3~M10

1. The dimensions and the specifications of 2P-A type are in red data.



- CRANK type single-jaw with the large through-hole and extra long jaw stroke.
- Suitable for clamping the jig or irregular work piece.
- High rigidity and high clamping accuracy.

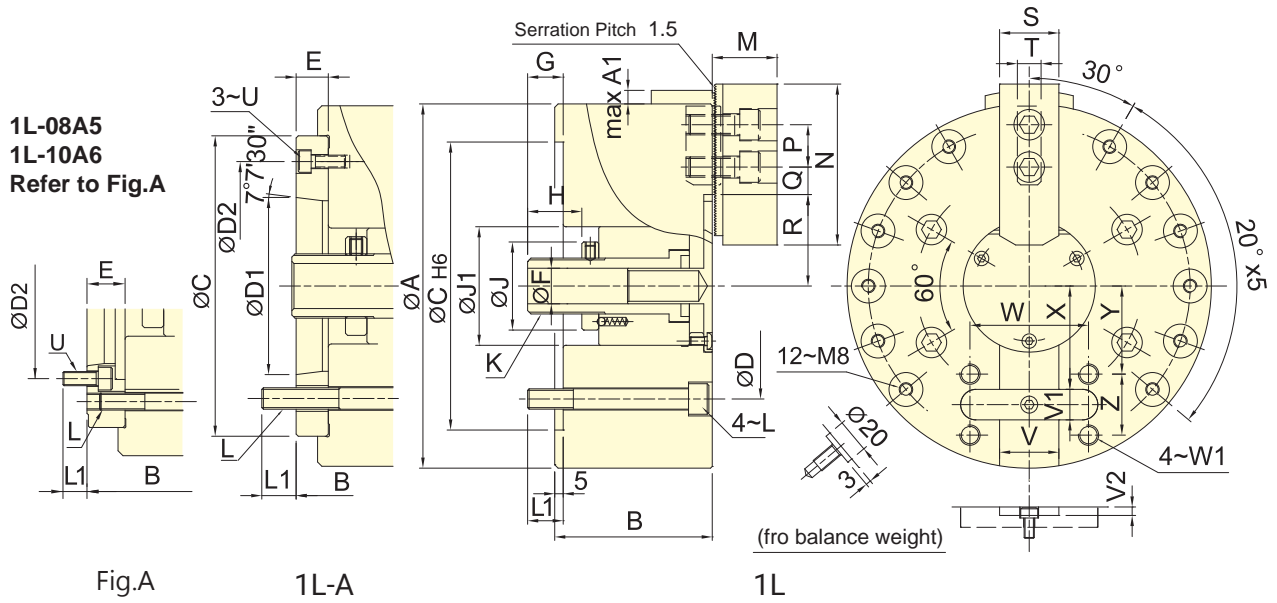

Subject to technical changes

SPECIFICATIONS

Model	Plunger stroke mm	Jaw stroke mm	Chucking Dia. Max. mm	Chucking Dia. Min. mm	Max. D.B. pull kN (kgf)	Max. Clamping force kN (kgf)	Max. speed min ⁻¹ (r.p.m.)	Moment of inertia kg · m ²	Weight		Matching cyl.	Max. pressure MPa(kgf/cm ²)	
									kg				
1L-06	A5	20	16	168	5	12.3(1250)	27.3(2780)	3800	0.05	12.5	14.3	RK-100	1.7(17.5)
1L-08	A5	25	20	215	7	15.7(1600)	37.2(3800)	3000	0.15	24.2	27.1	RK-125	1.4(14.3)
1L-08	A6	25	20	215	7	15.7(1600)	37.2(3800)	3000	0.15	24.2	25.3	RK-125	1.4(14.3)
1L-10	A6	30	24	254	17	21.6(2200)	48.5(4950)	2400	0.28	38.8	46	RK-125	1.9(19.5)
1L-10	A8	30	24	254	17	21.6(2200)	48.5(4950)	2400	0.28	38.8	44.3	RK-125	1.9(19.5)

DIMENSIONS

Model	A	A1	B	C	D	D1	D2	E	F	G max.	G min.	H	J	J1	K max.	L	L1			
1L-06	A5	168	9.5	80	90	140	104.8	82.56	116	15	21	37	17	25	46	54	M30x1.5	M10	16	16
1L-08	A5	215	8	93	111	170	133.4	82.56	104.8	23	21	46	21	32	52	70	M33x1.5	M12	21	19
1L-08	A6	215	8	93	105	170	133.4	106.38	150	17	21	46	21	32	52	70	M33x1.5	M12	21	20
1L-10	A6	254	13.5	108	128	220	171.4	106.38	133.4	25	30	47	17	30	62	90	M45x1.5	M16	25	20
1L-10	A8	254	13.5	108	121	220	171.4	139.72	190	18	30	47	17	30	62	90	M45x1.5	M16	25	27

Model	M	N	P	Q max.	Q min.	R max.	R min.	S	T	U	V(H6)	V1(h9)	V2	W	W1	X	Y	Z	
1L-06	A5	37	73	20	19.75	7.75	46	30	31	12	M6	30	15	4.5	64	M10	44.5	36	30
1L-08	A5	38	95	25	25.25	10.25	54	34	35	14	M10	35	18	4.5	70	M12	61	52	36
1L-08	A6	38	95	25	25.25	10.25	54	34	35	14	M6	35	18	4.5	70	M12	61	52	36
1L-10	A6	43	110	30	33.75	11.25	67	43	40	16	M8	40	20	5	90	M12	71	58.5	45
1L-10	A8	43	110	30	33.75	11.25	67	43	40	16	M8	40	20	5	90	M12	71	58.5	45

1. The dimensions and the specifications of 1L-A type are in red data.



- CRANK type 3-jaw with the large through-hole and extra long jaw stroke.
- Matching surfaces of all parts hardened, ground and lubricated directly.
- High rigidity and high clamping accuracy.
- J is the hole diameter of blank draw nut .
K is the maximum thread specification and it could be customize.

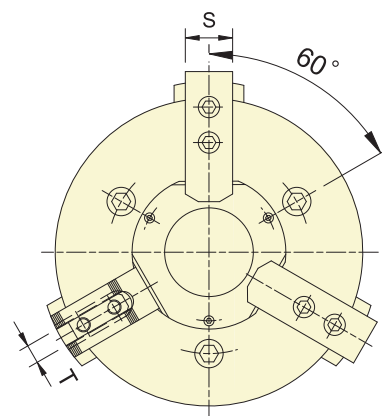
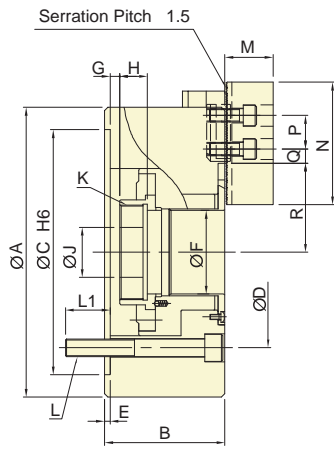
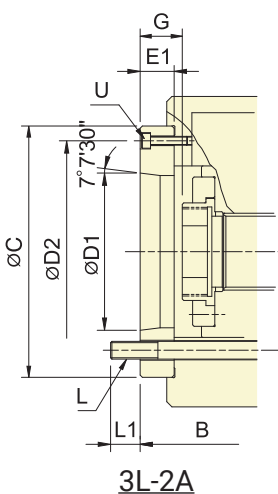
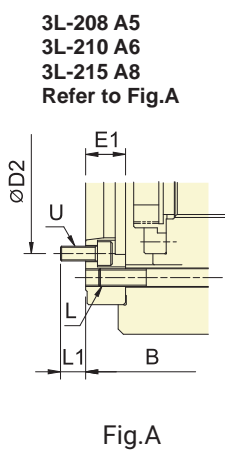

Subject to technical changes

SPECIFICATIONS

Model		Plunger stroke	Jawstroke (Dia.)	Chucking Dia. Max.	Chucking Dia. Min.	Max. D.B. pull	Max. Clamping force	Max. speed	Moment of inertia	Weight		Matching cyl.	Max. pressure
		mm	mm	mm	mm	kN (kgf)	kN (kgf)	min ⁻¹ (r.p.m.)	kg · m ²	kg	MPa (kgf/cm ²)		
3L-205	A4	12	18	138	6	15.6(1590)	17.2(1750)	4200	0.019	7.2	8	TK-A533	2.3(23)
3L-206	A5	15	24	170	24	23.5(2400)	26.0(2650)	3600	0.063	14.7	15.9	TK-C646	2.7(27)
3L-208	A5	20	32	215	30	34.3(3500)	35.0(3570)	3000	0.18	23	25.7	TK-A853	2.8(28)
3L-208	A6	20	32	215	30	34.3(3500)	35.0(3570)	3000	0.18	23	24.6	TK-A853	2.8(28)
3L-210	A6	25	37.5	260	53	47.7(4870)	48.0(4895)	2400	0.35	39.5	46.5	TK-A1075	3.1(31)
3L-210	A8	25	37.5	260	53	47.7(4870)	48.0(4895)	2400	0.35	39.5	45	TK-A1075	3.1(31)
3L-212	A8	30	45	315	61	64.7(6600)	61.0(6220)	2100	0.827	67.3	70.5	TK-A1291	3.0(30)
3L-215	A8	35	52	405	52	84.3(8600)	85.0(8665)	1600	2.58	139	152	TK-A1512	2.7(27)
3L-215	All	35	52	405	52	84.3(8600)	85.0(8665)	1600	2.58	139	145	TK-A1512	2.7(27)

1. The dimensions and the specifications of 3L-A type are in red data.

DIMENSIONS

Model	A	B	C	D	D1	D2	E	E1	F	G max.	G min.	H	J				
3L-205	A4	138	65	76	110	82.6	63.51	96	4	15	32	1	15	-11	3	20	12
3L-206	A5	170	84	97	140	104.8	82.56	116	5	18	45	6.5	24.5	-8.5	9.5	19	20
3L-208	A5	215	96	114	170	133.4	82.56	104.8	5	23	52	7	30	-13	10	20	30
3L-208	A6	215	96	114	170	133.4	106.38	150	5	23	52	7	30	-13	10	20	30
3L-210	A6	260	108	128	220	171.4	106.38	133.4	5	25	75	8.5	33	-16.5	8	25	45
3L-210	A8	260	108	121	220	171.4	139.72	190	5	18	75	8.5	26.5	-16.5	1.5	25	45
3L-212	A8	315	125	138	220	171.4	139.72	190	5	18	91	15	33	-15	3	30	50
3L-215	A8	405	150	177	300	235	139.72	171.4	6	33	120	12.5	45.5	-22.5	10.5	39	60
3L-215	A11	405	150	166	300	235	196.87	260	6	22	120	12.5	34.5	-22.5	-0.5	39	60

Model	K max.	L	L1	M	N	P	Q max.	Q min.	R max.	R min.	S	T	U			
3L-205	A4	M40x1.5	3~M10	15	15	31	62	14	15.75	5.25	38.5	29.5	25	10	3~M6	
3L-206	A5	M55x2	3~M10	18	15	37	73	20	15.25	7.75	51	39	31	12	3~M6	
3L-208	A5	M60x2	3~M12	18	19	38	95	25	19.25	10.25	63.5	47.5	35	14	6~M10	
3L-208	A6	M60x2	3~M12	18	20	38	95	25	19.25	10.25	63.5	47.5	35	14	3~M6	
3L-210	A6	M85x2	M60x2	3~M16	24	20	43	110	30	24.75	11.25	80	61.25	40	16	3~M12
3L-210	A8	M85x2	3~M16	24	21	43	110	30	24.75	11.25	80	61.25	40	16	3~M8	
3L-212	A8	M100x2	3~M16	24	21	51	130	30	29.75	13.25	96.5	74	50	21	3~M8	
3L-215	A8	M130x2	6~M20	33	27.5	63	165	43	34.75	13.75	119	93	62	25.5	6~M16	
3L-215	A11	M130x2	6~M20	33	31	63	165	43	34.75	13.75	119	93	62	25.5	3~M10	

1. The dimensions and the specifications of 3L-A type are in red data.



- CRANK type 2-jaw with the large through-hole and extra long jaw stroke.
- Matching surfaces of all parts hardened, ground and lubricated directly.
- High rigidity and high clamping accuracy.
- J is the hole diameter of blank draw nut, K is the maximum thread specification and it could be customize.

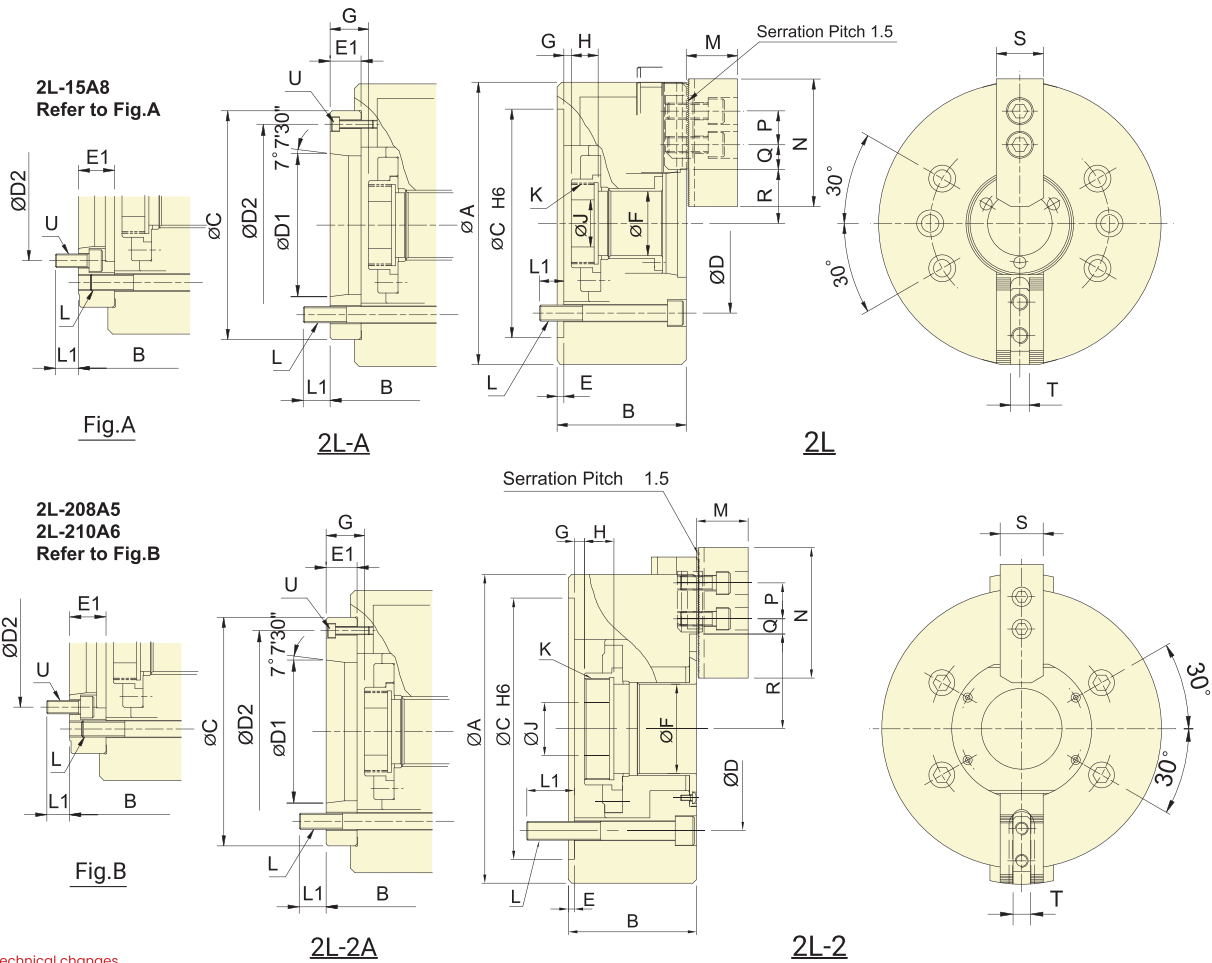

Subject to technical changes

SPECIFICATIONS

Model	Plunger stroke mm	Jawstroke (Dia.) mm	Chucking Dia. Max. mm	Chucking Dia. Min. mm	Max. D.B. pull kN (kgf)	Max. Clamping force kN (kgf)	Max. speed min ⁻¹ (r.p.m.)	Moment of inertia kg · m ²	Weight		Matching cyl.	Max. pressure MPa(kgf/cm ²)	
									kg				
2L-205	A4	12	18	138	6	10.4(1060)	11.4(1170)	4200	0.018	6.9	7.7	TK-A533	1.5(15)
2L-206	A5	15	24	170	24	15.7(1600)	17.3(1760)	3600	0.063	14.4	15.6	TK-C646	1.8(18)
2L-208	A5	20	32	215	30	22.9(2330)	27.1(2760)	3000	0.173	22	26	TK-A853	1.9(19)
2L-208	A6	20	32	215	30	22.9(2330)	27.1(2760)	3000	0.173	22	24.2	TK-A853	1.9(19)
2L-210	A6	25	37.5	260	53	31.8(3250)	37.3(3800)	2400	0.33	40	45.5	TK-A1075	2.1(21)
2L-210	A8	25	37.5	260	53	31.8(3250)	37.3(3800)	2400	0.33	40	44	TK-A1075	2.1(21)
2L-12	A8	30	45	304	30	43.1(4400)	50.0(5100)	2100	0.8	60	65.5	TK-A1291	2.0(20)
2L-15	A8	35	52	385	26	56.2(5730)	53.0(5400)	1600	2.52	133	147	TK-A1512	1.8(18)
2L-15	All	35	52	385	26	56.2(5730)	53.0(5400)	1600	2.52	133	140	TK-A1512	1.8(18)

1. The dimensions and the specifications of 2L-A type are in red data.

DIMENSIONS

Model	A	B		C	D	D1	D2	E	E1	F	G max.		G min.		H	J	
2L-205	A4	138	65	76	110	82.6	63.51	96	4	15	32	1	15	-11	3	20	12
2L-206	A5	170	84	97	140	104.8	82.56	116	5	18	45	6.5	24.5	-8.5	9.5	19	20
2L-208	A5	215	96	114	170	133.4	82.56	104.8	5	23	52	7	30	-13	10	20	30
2L-208	A6	215	96	114	170	133.4	106.38	150	5	23	52	7	30	-13	10	20	30
2L-210	A6	260	108	128	220	171.4	106.38	133.4	5	25	75	8.5	33	-16.5	8	25	45
2L-210	A8	260	108	121	220	171.4	139.72	190	5	18	75	8.5	26.5	-16.5	1.5	25	45
2L-12	A8	304	127	140	220	171.4	139.72	190	5	18	91	15	33	-15	3	28	50
2L-15	A8	385	150	177	300	235	139.72	171.4	6	33	120	12.5	45.5	-22.5	10.5	39	60
2L-15	All	385	150	166	300	235	196.87	260	6	22	120	12.5	34.5	-22.5	-0.5	39	60

Model	K max.	L	L1		M	N	P	Q max.	Q min.	R max.	R min.	S	T	U		
2L-205	A4	M40x1.5	4~M10	15	15	31	62	14	15.75	5.25	38.5	29.5	25	10	3~M6	
2L-206	A5	M55x2	4~M10	18	15	37	73	20	15.25	7.75	51	39	31	12	3~M6	
2L-208	A5	M60x2	4~M12	18	19	38	95	25	19.25	10.25	63.5	47.5	35	14	6~M10	
2L-208	A6	M60x2	4~M12	18	20	38	95	25	19.25	10.25	63.5	47.5	35	14	3~M6	
2L-210	A6	M85x2	M60x2	4~M16	24	20	43	110	30	24.75	11.25	80	61.25	40	16	6~M12
2L-210	A8	M85x2	4~M16	24	21	43	110	30	24.75	11.25	80	61.25	40	16	3~M8	
2L-12	A8	M100x2	6~M16	22	19	51	130	30	46.25	19.25	77	54.5	50	21	3~M8	
2L-15	A8	M130x2	6~M20	33	27.5	63	165	43	51.25	27.25	94.25	68.25	62	25.5	6~M16	
2L-15	All	M130x2	6~M20	33	31	63	165	43	51.25	27.25	94.25	68.25	62	25.5	3~M10	

1. The dimensions and the specifications of 2L-A type are in red data.

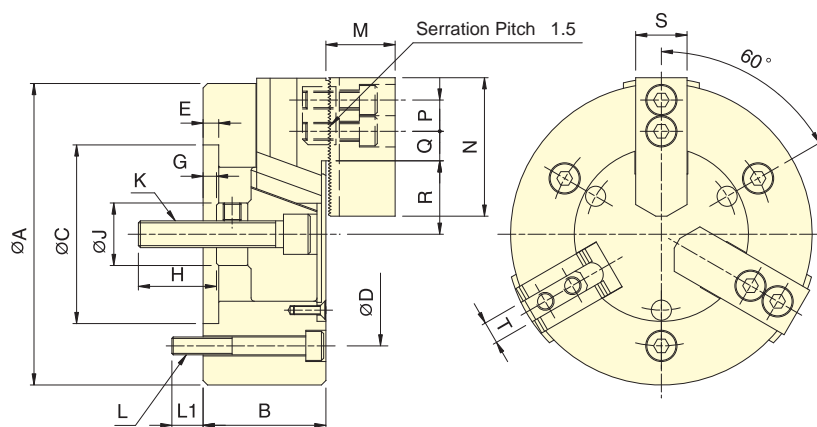
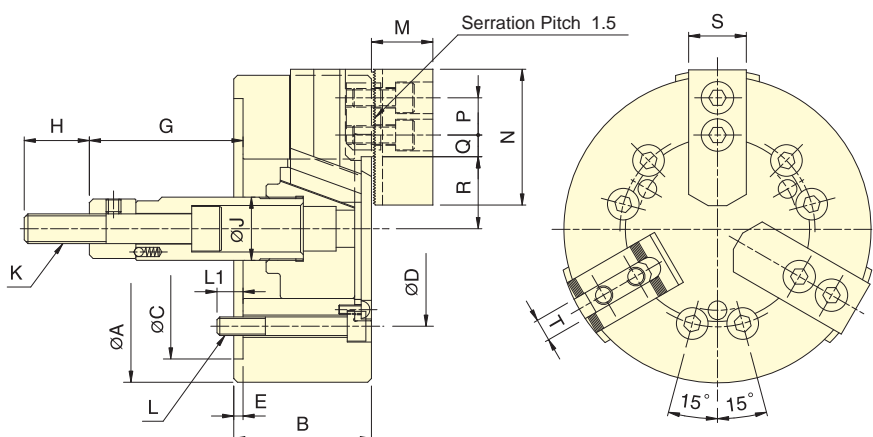

- WEDGE-HOOK type 3-jaw power chuck and extra long jaw stroke.
- Matching surfaces of all parts hardened, ground and lubricated directly.
- High rigidity and high clamping accuracy.

3M-05

3M-06~3M-12

Subject to technical changes

SPECIFICATIONS

Model	Plunger stroke	Jawstroke (Dia.)	Chucking Dia. Max.	Chucking Dia. Min.	Max. D.B. pull	Max. Clamping force	Max. speed	Moment of inertia	Weight	Matching cyl.	Max. pressure MPa (kgf/cm ²)
	mm	mm	mm	mm	kN (kgf)	kN (kgf)	min ⁻¹ (r.p.m.)	kg · m ²	kg		
3M-05	15	10.9	135	14	9.8 (1000)	23 (2350)	4500	0.02	6.0	RK-75(N)	2.7(27)
3M-06	20	14.5	165	14	21.6 (2200)	50 (3680)	4000	0.04	12.2	RK-100(N)	3.0(30)
3M-08	23	16.7	210	17	29.4 (3000)	72 (7340)	3500	0.13	23.0	RK-125(N)	2.9(29)
3M-10	27	19.6	254	22	39.2 (4000)	102 (10400)	3000	0.3	34.3	RK-150(N)	2.8(28)
3M-12	30	21.8	304	26	54.0 (5500)	150 (15300)	2500	0.71	59.4	RK-150(N)	3.6(36)

DIMENSIONS

Model	A	B	C(H6)	D	E	G max.	G min.	H	J	K
3M-05	135	55	80	100	7	6	-9	35	28	M12x1.75
3M-06	165	74	140	104.8	5	101.6	81.6	36	34	M16x2
3M-08	210	85	170	133.4	5	129	106	36	38	M20x2.5
3M-10	254	89	220	171.4	5	160	133	36	45	M20x2.5
3M-12	304	106	220	171.4	6	70	40	46	50	M24x3

Model	L	L1	M	N	P	Q max.	Q min.	R max.	R min.	S	T
3M-05	3~M8	14	31	62	14	15.5	5	32.9	27.45	25	10
3M-06	6~M10	14	37	73	20	17	8	38.7	31.45	31	12
3M-08	6~M12	20	38	95	25	22.3	8.8	47.5	39.15	35	14
3M-10	6~M16	18	43	110	30	32.3	12.8	53.9	44.1	40	16
3M-12	6~M16	18	51	130	30	47.8	13.3	62.5	51.6	50	21



- WEDGE-HOOK type 3-jaw power chuck and extra long jaw stroke.
- Matching surfaces of all parts hardened, ground and lubricated directly.
- High rigidity and high clamping accuracy.

Serration Pitch
 3M-215, 3M-218 : 1.5
 3M-221, 3M-224 : 3.0

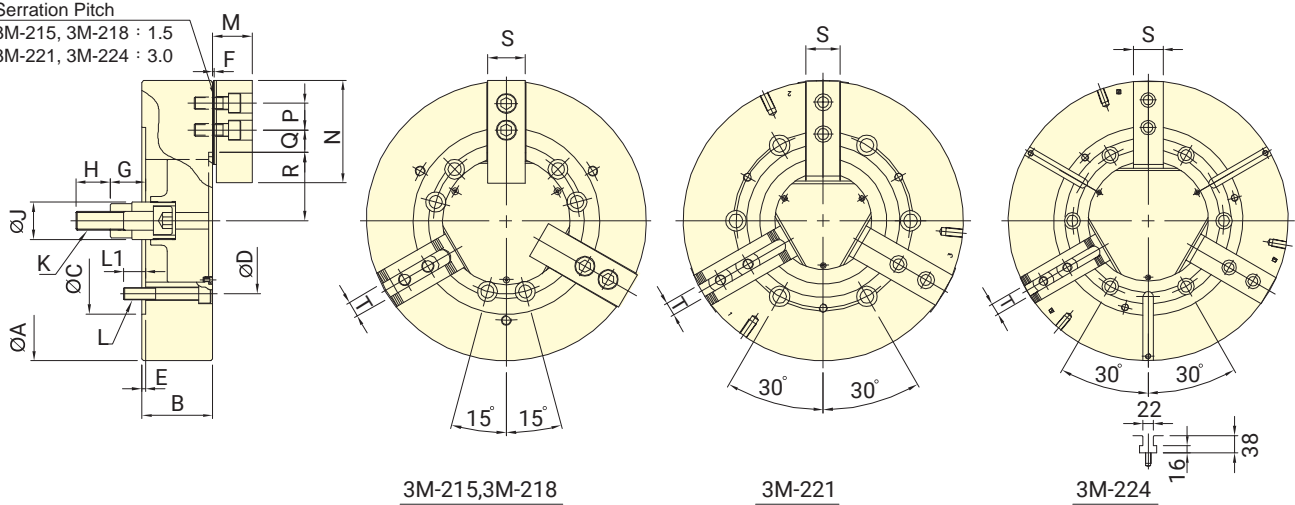

Subject to technical changes

SPECIFICATIONS

Model	Plunger stroke	Jaw stroke (Dia.)	Chucking Dia. Max.	Chucking Dia. Min.	Max. D.B. pull	Max. Clamping force	Max. speed	Moment of inertia	Weight	Matching cyl.	Max. pressure
	mm	mm	mm	mm	kN (kgf)	kN (kgf)	min ⁻¹ (r.p.m.)	kg · m ²	kg		MPa (kgf/cm ²)
3M-215	35	25.4	381	20	91.0 (9280)	158.9 (16200)	2300	1.8	96	RK-200(N)	3.0(30)
3M-218	35	25.4	450	51	91.0 (9280)	158.9 (16200)	2000	2.32	124	RK-200(N)	3.0(30)
3M-221	35	25.4	530	53	91.0 (9280)	158.9 (16200)	1350	4.9	175	RK-200(N)	3.0(30)
3M-224	35	25.4	610	160	91.0 (9280)	158.9 (16200)	1250	7.2	225	RK-200(N)	3.0(30)

DIMENSIONS

Model	A	B	C(H6)	D	E	F	G max.	G min.	H	J
3M-215	381	114	300	235	6	2	104	69	55	60
3M-218	450	114	300	235	6	2	92	57	55	60
3M-221	530	125	380	330.2	6	3	97	62	55	60
3M-224	610	125	380	330.2	6	3	97	62	55	60

Model	K	L	L1	M	N	P	Q max.	Q min.	R max.	R min.	S	T
3M-215	M30x3.5	6~M20	30	63.3	165	43	49.75	18.25	79	66.3	62	25.5
3M-218	M30x3.5	6~M20	35	63.3	165	43	51.25	18.25	109.5	96.8	62	25.5
3M-221	M30x3.5	6~M24	31	71	180	60	90.5	24.5	92	79.3	65	25
3M-224	M30x3.5	6~M24	31	71	180	60	90	24	131	118.3	65	25



- WEDGE-HOOK type 2-jaw power chuck and extra long jaw stroke.
- Matching surfaces of all parts hardened, ground and lubricated directly.
- High rigidity and high clamping accuracy.

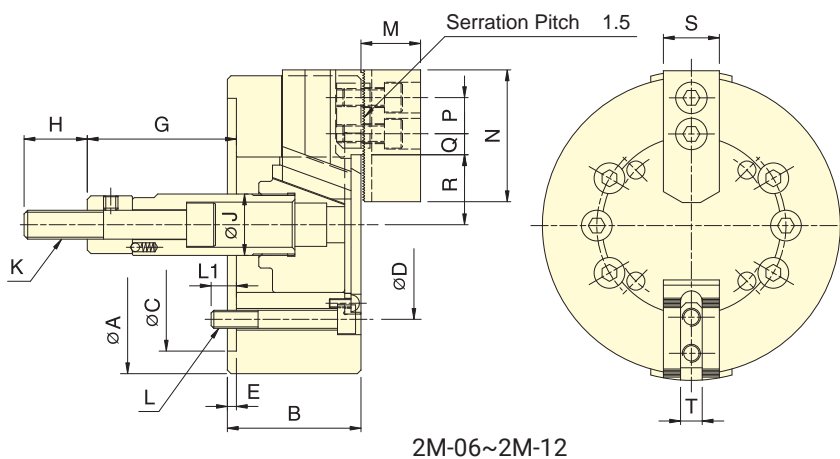
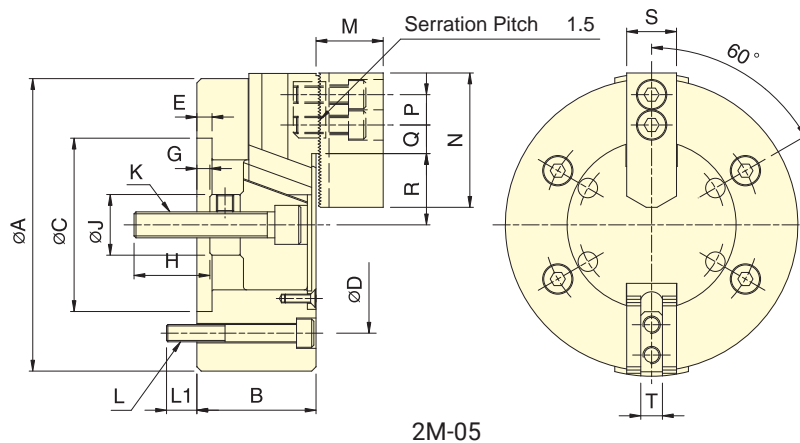

Subject to technical changes

SPECIFICATIONS

Model	Plunger stroke mm	Jaw stroke (Dia.) mm	Chucking Dia. Max. mm	Chucking Dia. Min. mm	Max. D.B. pull kN (kgf)	Max. Clamping force kN (kgf)	Max. speed min ⁻¹ (r.p.m.)	Moment of inertia kg · m ²	Weight kg	Matching cyl.	Max. pressure MPa (kgf/cm ²)
2M-05	15	10.9	135	14	6.5(660)	11(1120)	4500	0.02	6.0	RK-75(N)	1.8(18)
2M-06	20	14.5	165	14	14.3(1460)	24(2450)	4000	0.04	12.2	RK-100(N)	2.0(20)
2M-08	23	16.7	210	17	19.6(2000)	36.6(3730)	3500	0.13	23.0	RK-125(N)	1.9(19.3)
2M-10	27	19.6	254	22	26.1(2660)	49.3(5030)	3000	0.30	34.3	RK-150(N)	1.8(18.6)
2M-12	30	21.8	304	26	36(3670)	66(6730)	2500	0.71	59.1	RK-150(N)	2.4(24)

DIMENSIONS

Model	A	B	C(H6)	D	E	G max.	G min.	H	J
2M-05	135	55	80	100	7	6	-9	35	28
2M-06	165	74	140	104.8	5	101.6	81.6	36	34
2M-08	210	85	170	133.4	5	129	106	36	38
2M-10	254	89	220	171.4	5	160	133	36	45
2M-12	304	106	220	171.4	6	70	40	46	50

Model	K	L	L1	M	N	P	Q max.	Q min.	R max.	R min.	S	T
2M-05	M12x1.75	4~M8	14	31	62	14	15.5	5	32.9	27.45	25	10
2M-06	M16x2	6~M10	14	37	73	20	17	8	38.7	31.45	31	12
2M-08	M20x2.5	6~M12	20	38	95	25	22.3	8.8	47.5	39.15	35	14
2M-10	M20x2.5	6~M16	18	43	110	30	32.3	12.8	53.9	44.1	40	16
2M-12	M24x3	6~M16	18	51	130	30	47.8	13.3	62.5	51.6	50	21



- WEDGE-HOOK type 3-jaw high speed power chuck.
- Sealed against swarf, chips and coolant, suitable for vertical lathe.

3V-15A8
3V-15A15
3V-18A8
3V-18A15
3V-21A11
3V-24A11
Refer to Fig.A

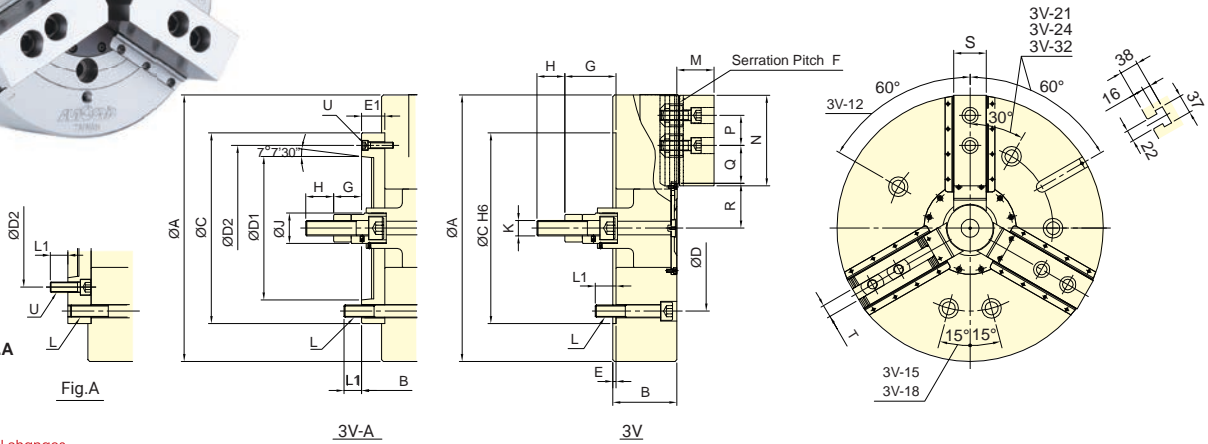

Subject to technical changes

SPECIFICATIONS

Model	Plunger stroke mm	Jawstroke (Dia.) mm	Chucking Dia. Max. mm	Chucking Dia. Min. mm	Max. D.B. pull kN (kgf)	Max. Clamping force kN (kgf)	Max. speed min ⁻¹ (r.p.m.)	Moment of inertia		Weight		Matching cyl.	Max. pressure MPa (kgf/cm ²)	
								kg · m ²	kg	kg	kg			
3V-12	A8	30	12.7	304	30	41(4180)	156(15900)	3150	0.73	0.79	62.9	68.7	RK-150 RE-150	2.6(26)
3V-15	A8	35	16	381	30	81.9(8360)	245.1(25000)	2900	1.97	2.27	105.5	128.5	RK-200 RE-200K	2.8(28) 3.0(30)
3V-15	A11	35	16	381	30	81.9(8360)	245.1(25000)	2900	1.97	2.27	105.5	127		
3V-15	A15	35	16	381	30	81.9(8360)	245.1(25000)	2900	3.33	2.67	105.5	142		
3V-18	A8	35	16	450	80	81.9(8360)	245.1(25000)	2600	3.33	3.62	132.7	155.5		
3V-18	A11	35	16	450	80	81.9(8360)	245.1(25000)	2600	3.33	3.63	132.7	154.5		
3V-18	A15	35	16	450	80	81.9(8360)	245.1(25000)	2600	6.83	4.02	132.7	165		
3V-21	A11	35	16	530	62	81.9(8360)	271.6(27700)	1800	6.83	7.46	196.5	227		
3V-21	A15	35	16	530	62	81.9(8360)	271.6(27700)	1800	6.83	7.37	196.5	221		
3V-24	A11	35	16	610	136	81.9(8360)	271.6(27700)	1700	11.19	11.83	241.7	272.8		
3V-24	A15	35	16	610	136	81.9(8360)	271.6(27700)	1700	11.19	11.73	241.7	266		
3V-32	A15	35	16	800	136	81.9(8360)	271.6(27700)	1100	28.97	29.51	353.6	378		

DIMENSIONS

Model	A	B	C	D	D1	D2	E	E1	F	G max.	G min.	H	J				
3V-12	A8	304	107	141	220	171.4	139.72	190	6	40	1.5	113	73	83	43	36	50
3V-15	A8	381	116	164	300	235	139.72	171.4	6	54	1.5	153	99	118	64	55	60
3V-15	A11	381	116	168	300	235	196.87	260	6	58	1.5	153	95	118	60	55	60
3V-15	A15	381	116	172	380	235	285.78	330.2	6	62	1.5	153	91	118	56	55	60
3V-18	A8	450	116	164	300	235	139.72	171.4	6	54	1.5	118	99	83	64	55	60
3V-18	A11	450	116	168	300	235	196.87	260	6	58	1.5	118	95	83	60	55	60
3V-18	A15	450	116	172	380	235	285.78	330.2	6	62	1.5	118	91	83	56	55	60
3V-21	A11	530	127	167	380	330.2	196.87	235	6	46	3	137	91	102	56	55	60
3V-21	A15	530	127	167	380	330.2	285.78	330.2	6	46	3	137	91	102	56	55	60
3V-24	A11	610	127	167	380	330.2	196.87	235	6	46	3	137	91	102	56	55	60
3V-24	A15	610	127	167	380	330.2	285.78	330.2	6	46	3	137	91	102	56	55	60
3V-32	A15	800	127	167	380	330.2	285.78	330.2	6	46	3	137	91	102	56	55	60

Model	K	L	L1	M	N	P	Q max.	Q min.	R max.	R min.	S	T	U		
3V-12	A8	M20x2.5	3~M16	24	24	54	130	30	47.5	16	61	54.65	50	21	3~M8
3V-15	A8	M30x3.5	6~M20	35	24	66	165	43	51.25	18.25	77.5	69.5	62	25.5	6~M16
3V-15	A11	M30x3.5	6~M20	35	32	66	165	43	51.25	18.25	77.5	69.5	62	25.5	3~M10
3V-15	A15	M30x3.5	6~M20	35	26	66	165	43	51.25	18.25	77.5	69.5	62	25.5	6~M24
3V-18	A8	M30x3.5	6~M20	35	24	66	165	43	51.25	18.25	108	100	62	25.5	6~M16
3V-18	A11	M30x3.5	6~M20	35	32	66	165	43	51.25	18.25	108	100	62	25.5	3~M10
3V-18	A15	M30x3.5	6~M20	35	26	66	165	43	51.25	18.25	108	100	62	25.5	6~M24
3V-21	A11	M30x3.5	6~M24	41	35	74	180	60	93.5	24.5	89	81	65	25	6~M20
3V-21	A15	M30x3.5	6~M24	41	35	74	180	60	93.5	24.5	89	81	65	25	3~M12
3V-24	A11	M30x3.5	6~M24	41	35	74	180	60	93.5	24.5	128	120	65	25	6~M20
3V-24	A15	M30x3.5	6~M24	41	35	74	180	60	93.5	24.5	128	120	65	25	3~M12
3V-32	A15	M30x3.5	6~M24	41	35	74	180	60	189.5	24.5	128	120	65	25	3~M12

- WEDGE-HOOK type 3-jaw high speed power chuck.
- With manual radial setting of master jaws for the workpiece centering.
- Sealed against swarf, chips and coolant, suitable for vertical lathe.

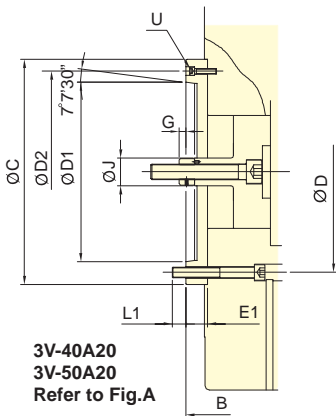

3V-40A20
3V-50A20
Refer to Fig.A

Fig.A

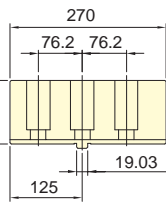
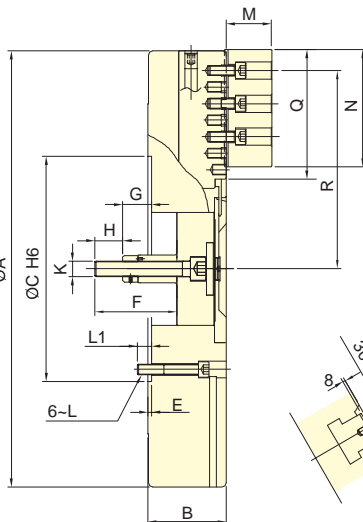

Soft jaw SJ-40-79

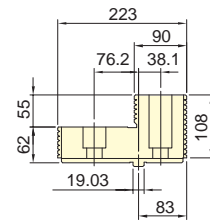
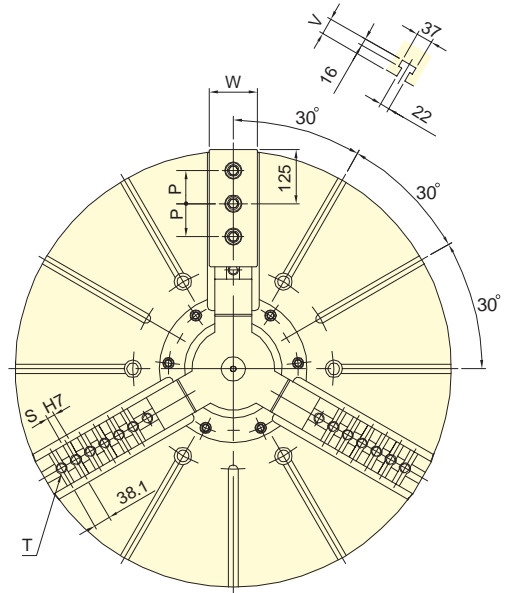

Hardened jaw HJ-40-79

Subject to technical changes

SPECIFICATIONS

Model	Plunger stroke	Jawstroke (Dia.)	Chucking Dia.Max.	Chucking Dia.Min.	Max. D.B. pull	Max.Clamping force	Max. speed	Moment of inertia	Weight		Matchingcyl.	Max. pressure		
									mm	mm			mm	mm
3V-40	A20	57	46+(60)	1005	310	180(18350)	320(32620)	630	68	72	780	849	RK-250 RE-250 RE-A250 RE-L250	4.2(42)
3V-50	A20	57	46+(60)	1250	290	180(18350)	320(32620)	500	145	148	1000	1050		4.2(42)
3V-63		60	48+(80)	1600	390	200(20390)	360(36700)	400	500	-	1600	-		4.6(46)
3V-79		60	48+(80)	2000	440	200(20390)	360(36700)	320	1250	-	2500	-		4.6(46)

DIMENSIONS

Model	A	B	C	D	D1	D2	E	E1	F	G max.	G min.	H	J	K				
3V-40	A20	1005	184	226	520	463.6	412.78	463.6	8	50	190	123	73	66	16	65	65	M36x4
3V-50	A20	1250	184	226	520	463.6	412.78	463.6	8	50	190	123	73	66	16	65	65	M36x4
3V-63		1600	222	-	720	647.6	-	-	8	-	218	131	-	71	-	65	-	M36x4
3V-79		2000	240	-	720	647.6	-	-	8	-	238	133	-	73	-	65	-	M36x4

Model	L	L1	M	N	P	Q	R max.	R min.	S	T	U	V	W	
3V-40	A20	M24	37	110	270	76.2	295	457	404	6~19.03	7~M24	3~M12	42	84
3V-50	A20	M24	37	110	270	76.2	416	563	510	9~19.03	9~M24	3~M12	42	84
3V-63		M30	46	110	270	76.2	540	738	674	12~19.03	13~M24	-	42	110
3V-79		M30	48	110	270	76.2	740	914	850	16~19.03	17~M24	-	42	110

1. The dimensions and the specifications of 3V-A type are in red data.

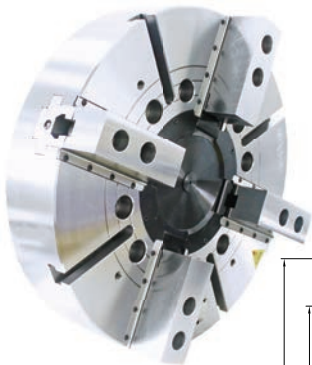

- WEDGE-HOOK type 4-jaw high speed power chuck.
- Sealed against swarf, chips and coolant, suitable for vertical lathe.

4V-15A8
4V-15A15
4V-18A8
4V-15A15
4V-21A11
4V-24A11
Refer to Fig.A

Fig.A

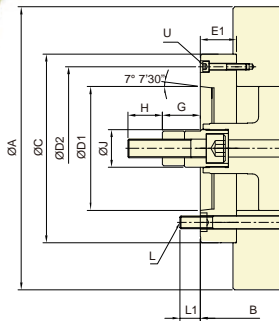

4V-A

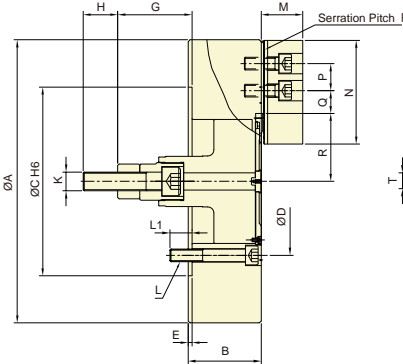

4V

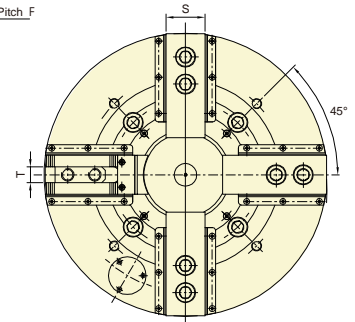

Subject to technical changes
SPECIFICATIONS

Model	Plunger stroke	Jaw stroke (Dia.)	Chucking Dia. Max.	Chucking Dia. Min.	Max. D.B. pull	Max. Clamping force	Max. speed	Moment of inertia		Weight		Matching cyl.	Max. pressure	
								mm	mm	mm	mm			mm
4V-12	A8	30	12.7	304	48	41(4180)	156(15900)	2520	0.72	0.79	59	67	RK-150 RE-150	2.6(26)
4V-15	A8	35	16	381	36	81.9(8360)	245.1(25000)	2300	2.10	2.39	108	131	RK-200 RE-200K	2.8(28) 3.0(30)
4V-15	A11	35	16	381	36	81.9(8360)	245.1(25000)	2300	2.10	2.39	108	130		
4V-15	A15	35	16	381	36	81.9(8360)	245.1(25000)	2300	2.10	2.79	108	139		
4V-18	A8	35	16	450	60	81.9(8360)	245.1(25000)	2050	3.51	3.80	139.3	162		
4V-18	A11	35	16	450	60	81.9(8360)	245.1(25000)	2050	3.51	3.80	139.3	160.9		
4V-18	A15	35	16	450	60	81.9(8360)	245.1(25000)	2050	3.51	4.20	139.3	172		
4V-21	A11	35	16	530	62	81.9(8360)	271.6(27700)	1450	6.98	7.62	199	230		
4V-21	A15	35	16	530	62	81.9(8360)	271.6(27700)	1450	6.98	7.53	199	223.7		
4V-24	A11	35	16	610	152	81.9(8360)	271.6(27700)	1350	11.34	11.98	243.8	275		
4V-24	A15	35	16	610	152	81.9(8360)	271.6(27700)	1350	11.34	11.88	243.8	268.3		
4V-32	A15	35	16	800	152	81.9(8360)	271.6(27700)	880	32.58	33.13	396	419.9		

DIMENSIONS

Model	A	B	C	D	D1	D2	E	E1	F	G max.	G min.	H	J				
4V-12	A8	304	107	141	220	171.4	139.72	190	6	40	1.5	113	73	83	43	36	50
4V-15	A8	381	116	164	300	235	139.72	171.4	6	54	1.5	153	99	118	64	55	60
4V-15	A11	381	116	168	300	235	196.87	260	6	58	1.5	153	95	118	60	55	60
4V-15	A15	381	116	172	380	235	285.78	330.2	6	62	1.5	153	91	118	56	55	60
4V-18	A8	450	116	164	300	235	139.72	171.4	6	54	1.5	118	99	83	64	55	60
4V-18	A11	450	116	168	300	235	196.87	260	6	58	1.5	118	95	83	60	55	60
4V-18	A15	450	116	172	380	235	285.78	330.2	6	62	1.5	118	91	83	56	55	60
4V-21	A11	530	127	167	380	330.2	196.87	235	6	46	3	137	91	102	56	55	60
4V-21	A15	530	127	167	380	330.2	285.78	330.2	6	46	3	137	91	102	56	55	60
4V-24	A11	610	127	167	380	330.2	196.87	235	6	46	3	137	91	102	56	55	60
4V-24	A15	610	127	167	380	330.2	285.78	330.2	6	46	3	137	91	102	56	55	60
4V-32	A15	800	147	187	380	330.2	285.78	330.2	6	46	3	100	54	65	19	55	60

Model	K	L	LI	M	N	P	Q max.	Q min.	R max.	R min.	S	T	U		
4V-12	A8	M20x2.5	3~M16	24	24	42	110	30	51.75	15.75	61.3	54.9	40	16	4~M8
4V-15	A8	M30x3.5	6~M20	35	24	66	165	43	40.75	18.25	87.5	79.4	62	25.5	6~M16
4V-15	A11	M30x3.5	6~M20	35	32	66	165	43	40.75	18.25	87.5	79.4	62	25.5	4~M10
4V-15	A15	M30x3.5	6~M20	35	26	66	165	43	40.75	18.25	87.5	79.4	62	25.5	6~M24
4V-18	A8	M30x3.5	6~M20	35	24	66	165	43	51.22	18.22	108	100	62	25.5	6~M16
4V-18	A11	M30x3.5	6~M20	35	32	66	165	43	51.22	18.22	108	100	62	25.5	4~M10
4V-18	A15	M30x3.5	6~M20	35	26	66	165	43	51.22	18.22	108	100	62	25.5	6~M24
4V-21	A11	M30x3.5	6~M24	41	35	74	180	60	72.5	24.5	89	81	65	25	6~M20
4V-21	A15	M30x3.5	6~M24	41	35	74	180	60	72.5	24.5	89	81	65	25	3~M12
4V-24	A11	M30x3.5	6~M24	41	35	74	180	60	93.5	24.5	128	120	65	25	6~M20
4V-24	A15	M30x3.5	6~M24	41	35	74	180	60	93.5	24.5	128	120	65	25	3~M12
4V-32	A15	M30x3.5	6~M24	36	35	74	180	60	189.5	24.5	128	120	65	25	3~M12



- WEDGE-HOOK type 4-jaw high speed power chuck.
- With manual radial setting of master jaws for the workpiece centering.
- Sealed against swarf, chips and coolant, suitable for vertical lathe.

4V-40 A20
4V-50 A20
4V-63 A20
Refer to Fig.A

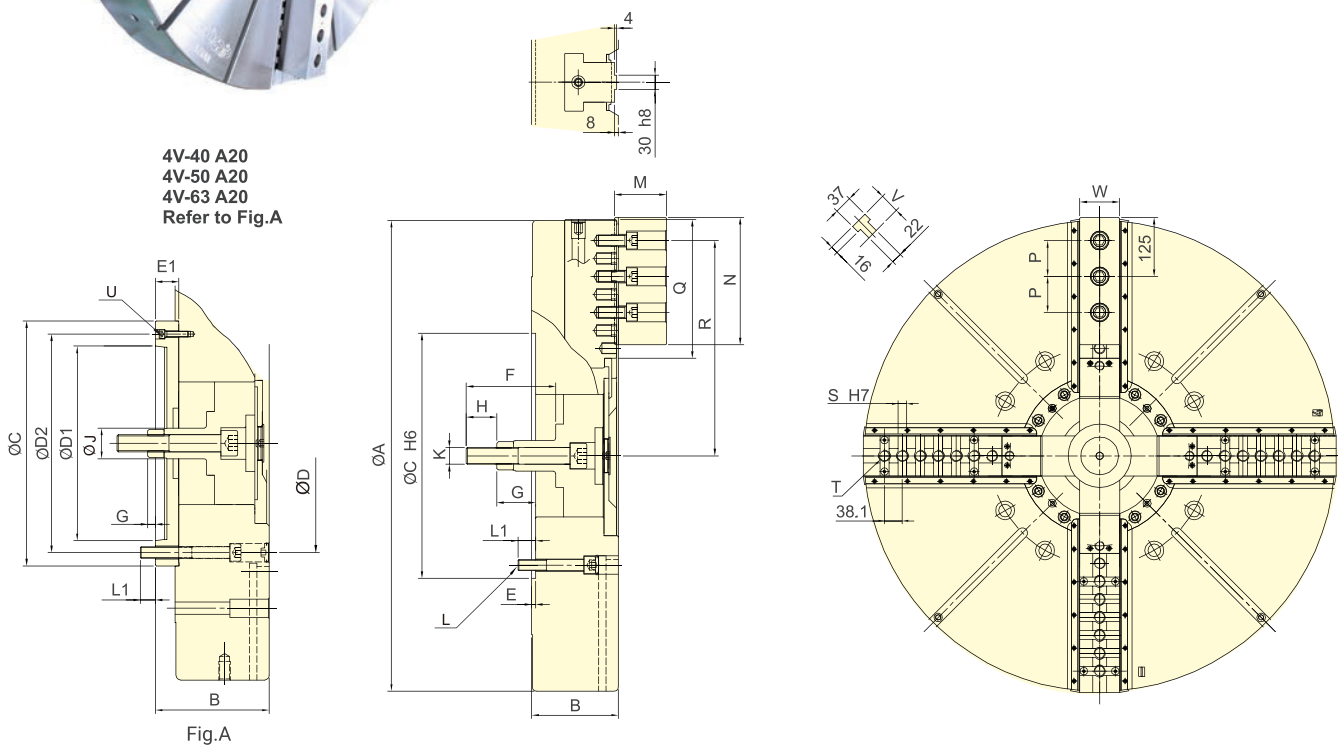

Subject to technical changes

SPECIFICATIONS

Model	Plunger stroke	Jaw stroke (Dia.)	Chucking Dia.Max.	Chucking Dia.Min.	Max. D.B. pull	Max.Clamping force	Max. speed	Moment of inertia		Weight		Matching cyl.	Max. pressure	
								kg · m ²	kg	MPa(kgf/cm ²)				
4V-40	A20	57	46+(60)	1000	310	180(18350)	320(32620)	500	70	94	740	790	RK-250	4.2(42)
4V-50	A20	57	46+(60)	1250	290	180(18350)	320(32620)	450	222	224	1130	1180	RE-250 RE-A250	4.2(42)
4V-63		60	48+(80)	1600	390	200(20390)	360(36700)	340	565		1800		RE-L250	4.6(46)

DIMENSIONS

Model	A	B	C	D	D1	D2	E	EI	F	G max.	G min.	H	J	K				
4V-40	A20	1000	184	226	520	463.6	412.78	463.6	8	50	190	139	89	82	32	65	65	M36x4
4V-50	A20	1250	200	242	520	463.6	412.78	463.6	8	50	190	123	73	66	16	65	65	M36x4
4V-63		1600	240	-	720	647.6	-	-	8	-	214	131		71		65	-	M36x4

Model	L	L1	M	N	P	Q	R max.	R min.	S	T	U	V	W	
4V-40	A20	M24	37	110	270	76.2	295	457	404	6~19.03	7~M24	3~M12	42	84
4V-50	A20	M24	38	110	270	76.2	416	563	510	9~19.03	9~M24	3~M12	45	84
4V-63		M30	46	110	270	76.2	540	738	674	12~19.03	13~M24	-	42	110

1. The dimensions and the specifications of 4V-A type are in red data.



- Fully sealed design extends maintenance intervals, improving production efficiency.
- Sealed design ensures constant lubrication and protects against the ingress of coolant and chips, which guarantees clamping precision and durability.
- Suitable for lights-out manufacturing; dry machining of castings and forgings; or when high-pressure coolant is utilized. Especially ideal for vertical lathes.
- Media fed through central bore - available for coolant or air. (optional)

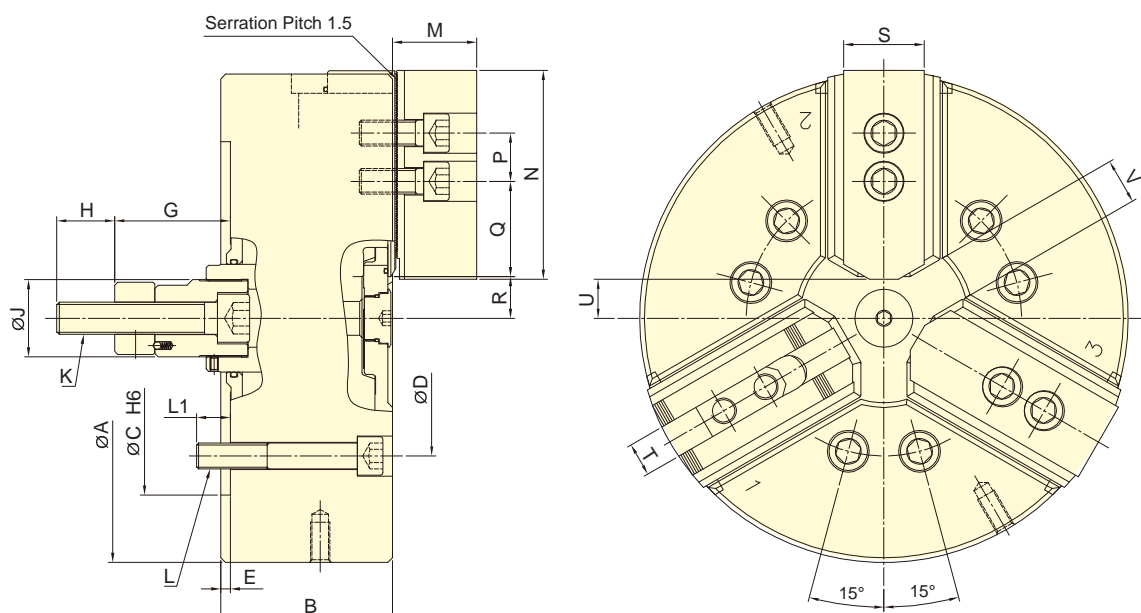

Subject to technical changes

SPECIFICATIONS

Model	Plunger stroke	Jawstroke (Dia.)	Chucking Dia.Max.	Chucking Dia.Min.	Max. D.B. pull	Max. clamping force	Max. speed	I	Weight	Matching cyl.	Max. pressure
	mm	mm	mm	mm	kN(kgf)	kN (kgf)	min ⁻¹ (r.p.m.)	kg · m ²	kg		MPa (kgf/cm ²)
3PS-12	30	12.6	304	22	38.5(3925)	160(16310)	3360	0.84	67	RK-150(N) RA-270	2.4(24.4) 0.7(7.4)

DIMENSIONS

Model	A	B	C	D	E	G max.	G min.	H	J	K	L	LI
3PS-12	315	107	220	171.4	6	72	42	39	48	M20x2.5	6-M16	21

Model	M	N	P	Q max.	Q min.	R max.	R min.	S	T	U max.	U min.	V max.	V min.
3PS-12	52.3	130	30	71.25	30.75	43	36.7	50	21	26	19.7	28	17



- The shortest changes time for soft jaw, it is the high repeatability precision.
- Chuck of all parts hardened, ground and lubricated directly.
- High rigidity and high clamping accuracy.
- For safety system that master jaw will complete return when base jaw and serration match up properly.

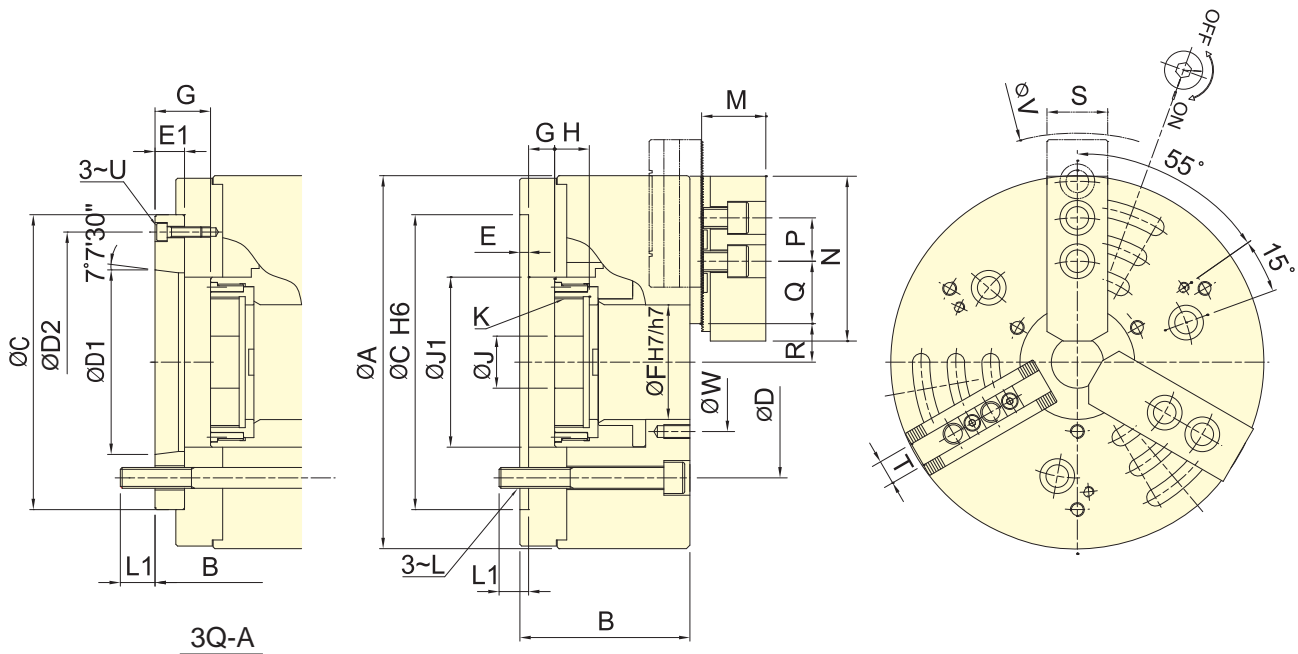

Subject to technical changes

SPECIFICATIONS

Model		Plunger stroke	Jaw stroke (Dia.)	Chucking Dia. Max.	Chucking Dia. Min.	Max. D.B. pull	Max. Clamping force	Max. speed	Moment of inertia	Weight	Matching cyl.	Max. pressure	
		mm	mm	mm	mm	kN (kgf)	kN (kgf)	min ⁻¹ (r.p.m.)	kg · m ²	kg		MPa (kgf/cm ²)	
3Q-08	A6	16	7.5	210	23	45.0(4590)	82.0(8360)	5000	0.15	24.5	26.0	TK-A1068	3.1(31)
3Q-10	A8	19	8.8	254	41	60.0(6118)	115.0(11270)	4500	0.41	44.0	46.0	TK-A1287	2.8(28)
3Q-12	A8	23	10.6	315	47	81.0(8259)	165.0(16825)	3500	0.96	73.0	75.0	TK-A1511	2.4(25)

DIMENSIONS

Model	A	B	C	D	D1	D2	E	E1	F	G max.	G min.	H	J				
3Q-08	A6	215	98	110	170	133.4	106.38	150	5	17	66	14.5	32	-1.5	15.5	20	30
3Q-10	A8	254	119	132	220	171.4	139.72	190	5	18	81	8.5	26.5	-10.5	7.5	39	45
3Q-12	A8	315	133	145	220	171.4	139.72	190	6	18	106	8.5	26.5	-14.5	3.5	42	50

Model	J1	K max.	L	L1	M	N	P	Q	R max.	R min.	S	T	U	V	W		
3Q-08	A6	98	M75x2	M12	17	20	37	95	25	36	20.8~44.8	17.1~41.1	35	14	M6	264	80
3Q-10	A8	115	M90x2	M16	23	25	42	110	30	40.5	21.1~52.8	16.7~48.2	40	16	M8	312	100
3Q-12	A8	140	M115x2	M16	22	24	50	110	30	57	34.1~70.1	28.8~64.8	50	21	M8	360	130

1. The dimensions and the specifications of 3Q-A type are in red data.



- The surface of the center through cover is grinding treated, it can be the position base surface of the jig/workpiece.
- The slideway of main jaws is inclined. It improves the clamping force and reduces the upfloat situation of the workpiece.
- Work with standard top jaws.
- Airtight pressure detect function is optional.
- External gripping only.

SPECIAL PURPOSE POWER CHUCKS

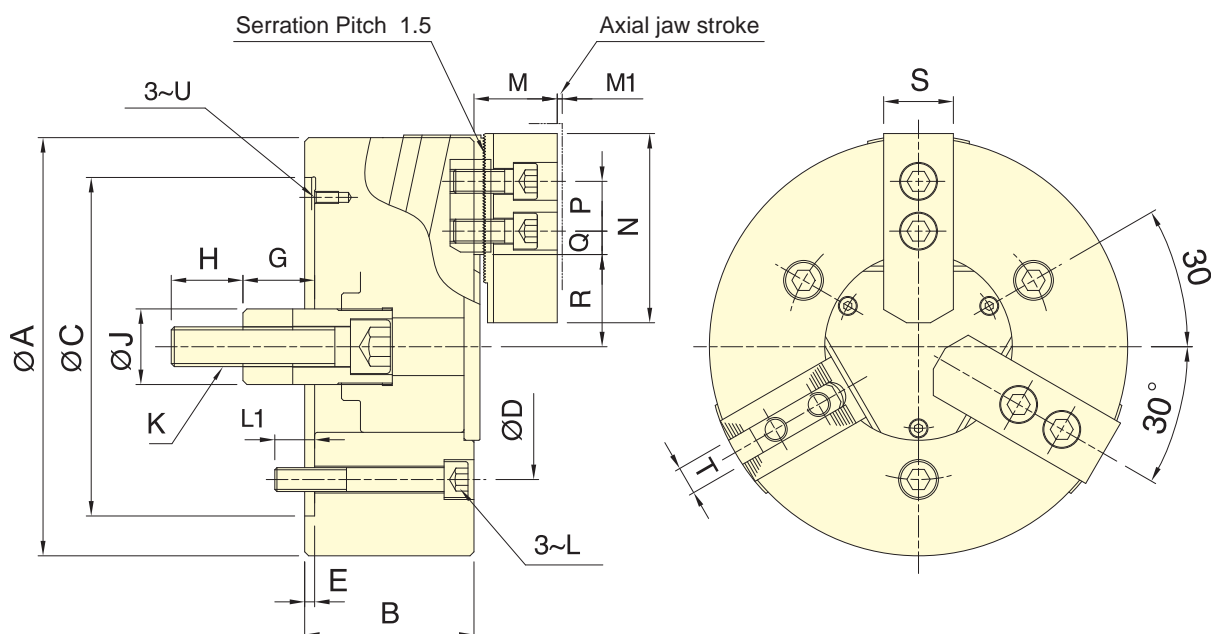

Subject to technical changes

SPECIFICATIONS

Model	Plunger stroke	Jaw stroke (Dia.)	Chucking Dia.Max.	Chucking Dia.Min.	Max. D.B. pull	Max. Clamping force	Max. speed	Moment of inertia	Weight	Matching cyl.	Max. pressure
	mm	mm	mm	mm	kN (kgf)	kN (kgf)	min ⁻¹ (r.p.m.)	kg · m ²	kg		MPa (kgf/cm ²)
3N-06	20	8.1 (axial 0.9)	165	14	18 (1835)	61.5 (6270)	5000	0.05	11.1	RK-100(N)	2.6 (26)
3N-08	23	9.4 (axial 1.0)	210	17	25 (2540)	85.8 (8750)	4500	0.14	24.5	RK-125(N)	2.2 (22)
3N-10	25	10.2 (axial 1.1)	254	22	29 (2950)	108 (11000)	4000	0.32	34.5	RK-150(N)	1.8 (18)

DIMENSIONS

Model	A	B	C(H6)	D	E	G max.	G min.	H	J	K	L
3N-06	165	72	140	104.8	5	54.5	34.5	36	34	M16x2	M10
3N-08	210	85	170	133.4	5	59	36	36	38	M20x2.5	M12
3N-10	254	89	220	171.4	5	63	38	36	45	M20x2.5	M16

Model	L1	M	M1	N	P	Q max.	Q min.	R max.	R min.	S	T	U
3N-06	16	41	0.9	73	20	15.25	7.75	38.3	34.25	31	12	M6
3N-08	20	42	1.0	95	25	22.25	11.75	46.3	41.6	35	14	M6
3N-10	24	47	1.1	110	30	33.75	11.25	52.1	47	40	16	M8

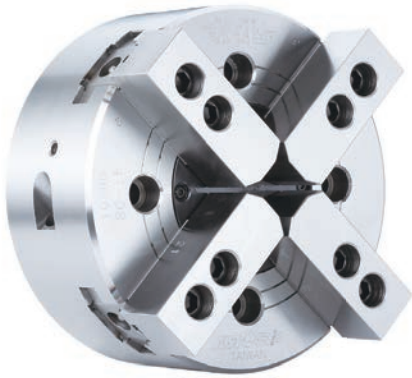

- CRANK type with two pairs of 2 jaws self center independent of each other.
- The 4T series is suitable for square bar and other nonuniform shaped workpieces.
- Patent numbers :
PAT.NO.M359385 (Taiwan)
PAT.NO.ZL200920009309.1(China)

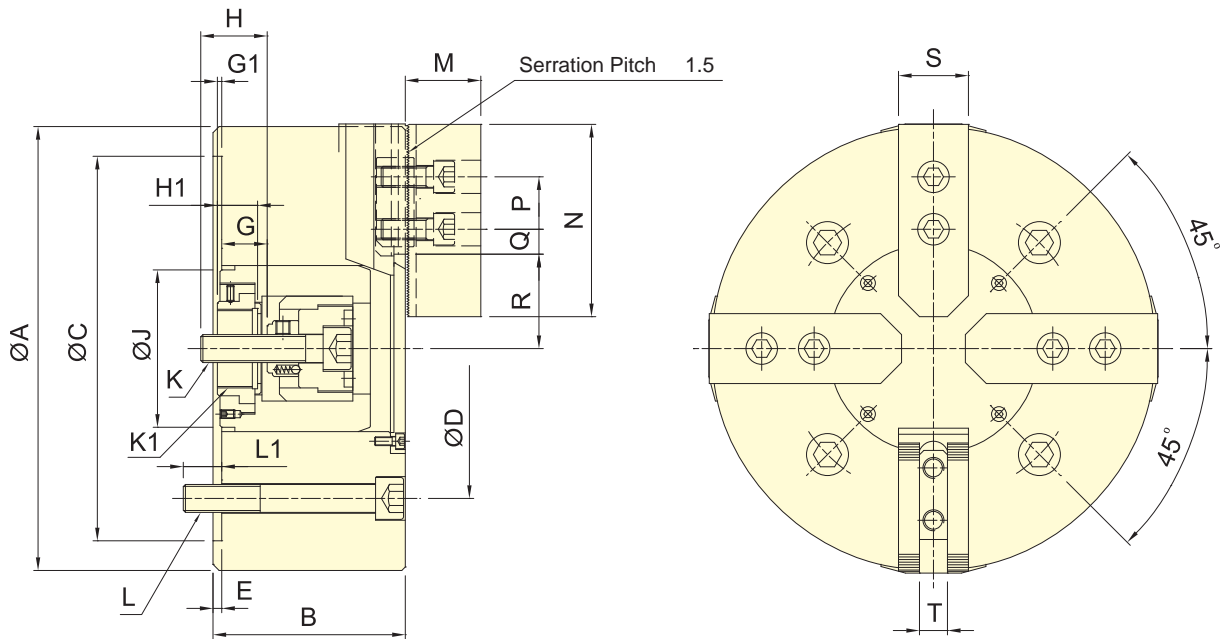

Subject to technical changes

SPECIFICATIONS

Model	Plunger stroke	Jaw stroke (Dia.)	Chucking Dia. Max.	Chucking Dia. Min.	Max. D.B. pull	Max. Clamping force	Max. speed	Moment of inertia	Weight	Matching cyl.	Max. pressure
	mm	mm	mm	mm	kN (kgf)	kN (kgf)	min ⁻¹ (r.p.m.)	kg · m ²	kg		MPa (kgf/cm ²)
4T-08	17	13.6	210	24	16.0(1630)	54.3(5540)	3000	0.15	23.2	RD-120(N)	1.7(17)
4T-10	20	16	254	50	21.6(2200)	79.4(8100)	2100	0.35	44.3	RD-125(N)	2.2(22)
4T-12	20	16	304	50	21.6(2200)	79.4(8100)	1500	0.66	57.6	RD-125(N)	2.2(22)
4T-15	25	19.6	381	60	27.2(2780)	105.3(10750)	1200	2.25	118.3	RD-125(N)	2.7(27)

DIMENSIONS

Model	A	B	C(H6)	D	E	G max.	G min.	G1 max.	G1 min.	H	H1	J	K
4T-08	210	91	170	133.4	5	32	15	2.5	-14.5	29	20	61	M14x2
4T-10	254	110	220	171.4	5	36.5	16.5	10	-10	36	23	90	M16x2
4T-12	304	110	220	171.4	5	36.5	16.5	10	-10	36	23	90	M16x2
4T-15	381	135	300	235	6	44.5	19.5	5	-20	45	28	125	M20x2.5

Model	K1	L	L1	M	N	P	Q max.	Q min.	R max.	R min.	S	T
4T-08	M34x1.5	4~M2	20	38	95	25	25.25	13.25	46.1	39.3	35	14
4T-10	M45x1.5	4~M16	25	43	110	30	32.25	12.75	59	51	40	16
4T-12	M45x1.5	4~M16	25	43	110	30	54.75	15.75	59	51	40	16
4T-15	M55x2	4~M20	30	51	130	30	66.5	12.5	78.9	69.1	50	21



- Radial clamp and axial pull down at the same time, keep the workpiece attaching close to the base surface of the chuck.
- Almost no workpiece uplifting displacement.
- The body and the cylinder pull-down mechanism are heat-treated and fine boring, which guarantee the clamping precision and durability.
- Airtight pressure detect function is optional.

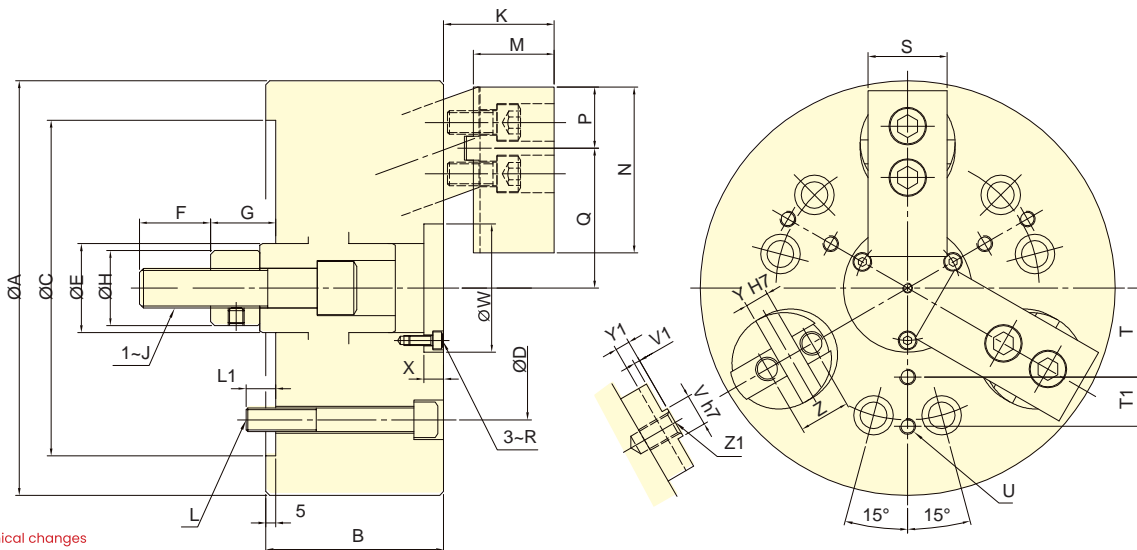

Subject to technical changes

SPECIFICATIONS

Model	Plunger stroke	Jaw stroke (Dia.)	Chucking Dia. Max.	Chucking Dia. Min.	Max. D.B. pull	Max. Clamping force	Max. speed	Moment of inertia	Weight	Matching cyl.	Max. pressure
	mm	mm	mm	mm	kN (kgf)	kN (kgf)	min ⁻¹ (r.p.m.)	kg · m ²	kg		MPa (kgf/cm ²)
3D-04	7	5	110	13	6.0(612)	10.5(1070)	3500	0.007	4.5	RK-75	1.6(16.5)
3D-05	7	5	135	21	10.0(1020)	17.0(1730)	3500	0.018	7.9	RK-75	2.7(27.5)
3D-06	10	7.2	165	22	15.0(1530)	25.0(2550)	3500	0.051	15	RK-100	2.1(21.4)
3D-08	10	7.2	210	28	25.0(2550)	45.0(4590)	3000	0.15	26	RK-125	2.2(22.5)
3D-10	15	10.8	254	35	35.0(3569)	60.0(6118)	2500	0.37	46	RK-125	3.1(31.6)
3D-12	15	10.8	304	50	45.0(4590)	75.0(7650)	2000	0.79	70	RK-150	2.8(28.5)
3D-15	20	14.5	381	60	53.9(5500)	90.0(9180)	1500	2.25	132	RK-150	3.4(34.2)

DIMENSIONS

Model	A	B	C	D	E	F	G max.	G min.	H	J	K max.	K min.	L	L1	M	N	P
3D-04	110	60	85	70.6	25	20	22	15	25	M10	30	23	3~M10	15	19.5	50	22
3D-05	135	70	110	82.6	30	25	24	17	28	M12	35	28	3~M10	16	24.5	56	23
3D-06	165	85	140	104.8	35	36	37	27	32	M16	45	35	6~M10	16	31	70	27
3D-08	210	90	170	133.4	45	36	38	28	38	M20	56	46	6~M12	15	41	84	31
3D-10	254	110	220	171.4	55	46	47	32	50	M24	65	50	6~M16	24	46	100	38
3D-12	304	125	220	171.4	55	50	49.5	34.5	53	M27	70	55	6~M16	22	51	120	42
3D-15	381	140	300	235	70	55	61	41	55	M30	86	66	6~M20	30	60	165	60

Model	Q max.	Q min.	R	S	T	T1	U	v (h7)	v1	w	x	Y(H7)	Y1	z	Z1
3D-04	37	34.5	M3	25	22.5	-	3~M6	8	2.5	35	2	8	6	-	M10
3D-05	46	43.5	M3	30	27.5	-	3~M6	8	2.5	44	2	8	6	-	M12
3D-06	57.7	54.3	M4	35	35	20	6~M6	10	2.5	52	7	10	6.5	-	M14
3D-08	70.8	67.2	M5	40	45	25	6~M8	16	3	65	10	12	7.5	26	M12
3D-10	85	79.6	M6	50	55	30	6~M8	18	3	75	12	15	7.5	32	M14
3D-12	101.9	96.5	M6	60	70	35	6~M10	20	3	90	12	17	7.5	36	M16
3D-15	135.6	128.3	M8	70	95	45	6~M12	24	4	120	13	20	6	40	M16



- Radial clamp and axial pull down at the same time, keep the workpiece attaching close to the base surface of the chuck.
- Almost no workpiece uplifting displacement.
- The body and the cylinder pull-down mechanism are heat-treated and fine boring, which guarantee the clamping precision and durability.
- Airtight pressure detect function is optional.

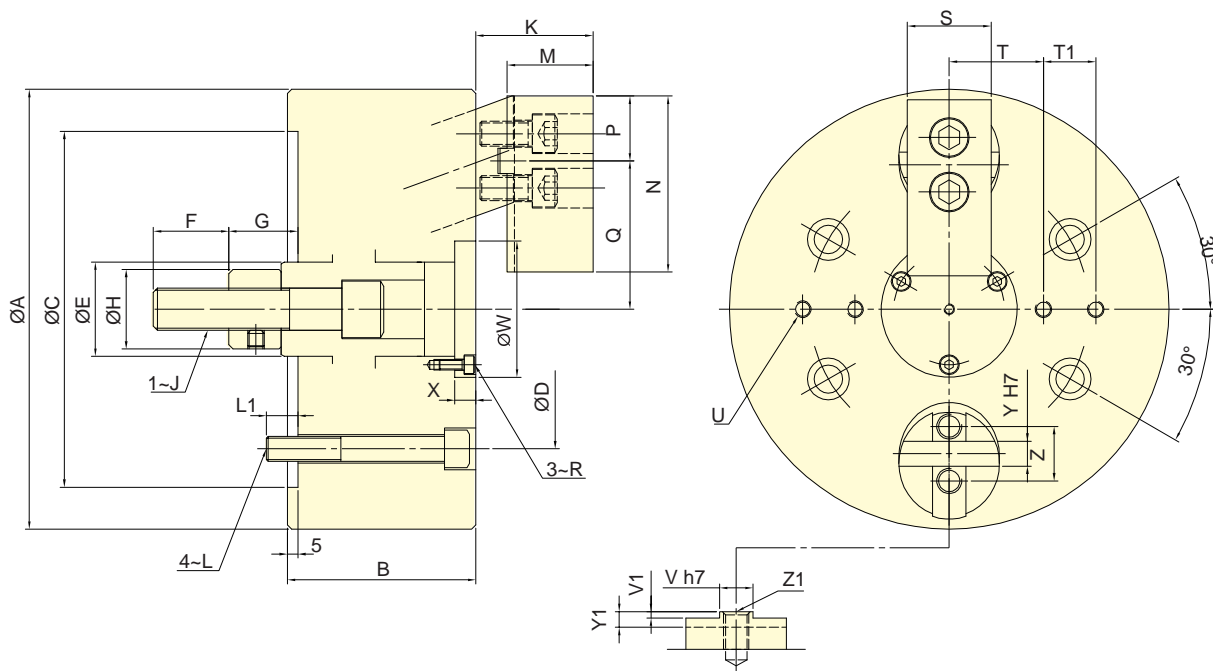

Subject to technical changes

SPECIFICATIONS

Model	Plunger stroke	Jaw stroke (Dia.)	Chucking Dia.Max.	Chucking Dia.Min.	Max. D.B. pull	Max. Clamping force	Max. speed	Moment of inertia	Weight	Matching cyl.	Max. pressure
	mm	mm	mm	mm	kN (kgf)	kN (kgf)	min ⁻¹ (r.p.m.)	kg · m ²	kg		MPa (kgf/cm ²)
2D-06	10	7.2	165	22	10.0(1020)	16.7(1700)	3500	0.045	12	RK-100	1.4(14.3)
2D-08	10	7.2	210	28	16.7(1700)	30.0(3060)	3500	0.13	23	RK-125	1.5(15)
2D-10	15	10.8	254	35	23.3(2379)	40.0(4079)	2500	0.34	43	RK-125	2.1(21.1)

DIMENSIONS

Model	A	B	C	D	E	F	G max.	G min.	H	J	K max.	K min.	L	L1	M	N	P
2D-06	165	85	140	104.8	35	36	37	27	32	M16	45	35	M10	16	31	70	27
2D-08	210	90	170	133.4	45	36	38	28	38	M20	56	46	M12	15	41	84	31
2D-10	254	110	220	171.4	55	46	47	32	50	M24	65	50	M16	24	46	100	38

Model	Q max.	Q min.	R	S	T	T1	U	V (h7)	V1	W	X	Y (H7)	Y1	Z	Z1
2D-06	57.7	54.3	M4	35	35	20	4-M6	10	2.5	52	7	10	6.5	-	M14
2D-08	70.8	67.2	M5	40	45	25	4-M8	16	3	65	10	12	7.5	26	M12
2D-10	85	79.6	M6	50	55	30	4-M8	18	3	75	12	15	7.5	32	M14



- Pin-Arbor Draw Down type 3-jaw thru-hole power chuck.
- High radial gripping force and high accuracy.
- Suitable for heavy machining.

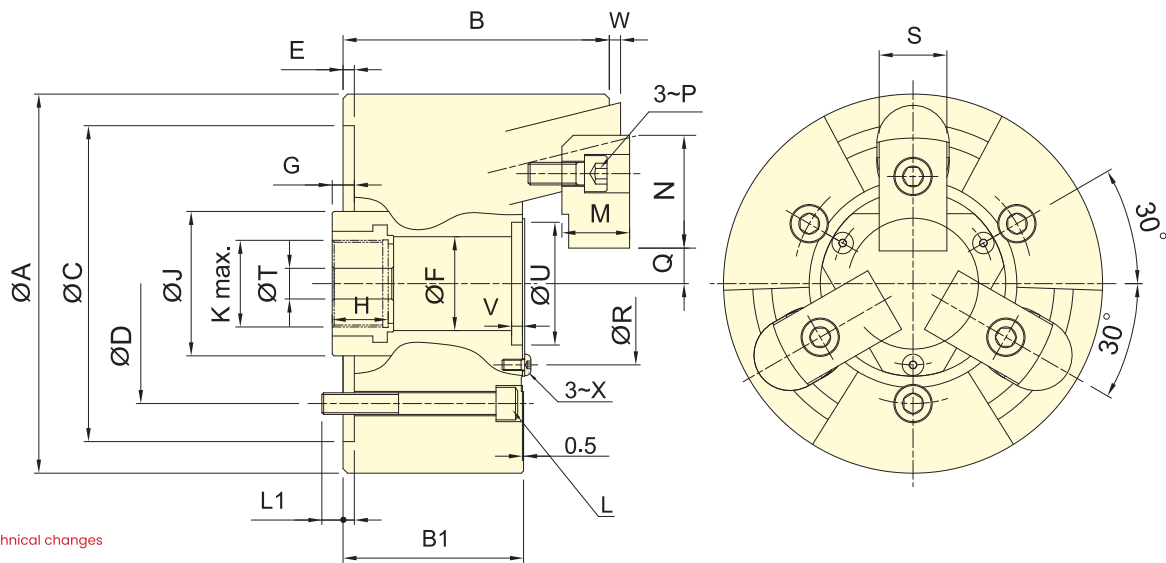

Subject to technical changes

SPECIFICATIONS

Model	Plunger stroke	Jaw stroke (Dia.)	Chucking Dia.Max.	Chucking Dia.Min.	Max. D.B. pull	Max. Clamping force	Max. speed	Moment of inertia	Weight	Matching cyl.	Max. pressure
	mm	mm	mm	mm	kN (kgf)	kN (kgf)	min ⁻¹ (r.p.m.)	kg · m ²	kg		MPa (kgf/cm ²)
3U-203	4	2	42	14	5.8(590)	16.7(1700)	10000	0.001	1.8	RK-75(N)	1.6(16)
3U-204	6	3	60	10	10.0(1020)	28.4(2900)	8000	0.005	3.9	RK-75(N)	2.7(27)
3U-205	6	3	84	15	13.9(1420)	39.7(4050)	8000	0.012	6.8	RK-100(N)	2.0(20)
3U-206	10	5	105	24	17.9(1830)	57.8(5900)	7000	0.055	14.7	RK-100(N)	2.6(26)
3U-208	12	6	132	25	25.0(2550)	80.0(8150)	6000	0.14	25.5	RK-125(N)	2.2(22)
3U-210	10	5	163	34	31.0(3160)	100.0(10100)	4500	0.36	43.5	RK-125(N)	3.1(31)
3U-212	10	5	210	81	35.0(3570)	100.0(10100)	3600	0.68	63.0	RK-125(N)	3.1(31)

DIMENSIONS

Model	A	B	B1	C(H6)	D	E	F	G max.	G min.	H	J	K	L	L1
3U-203	85	54.5	42	70	54	3.5	25	18	14	22	38	M20x1.5	3~M8	11
3U-204	110	72.5	55	85	70.6	4	30	16	10	24.5	42	M24x1.5	3~M10	12
3U-205	135	84.5	63	110	82.6	4	35	16	10	26	50	M28x1.5	3~M10	15
3U-206	168	118	80	140	104.8	5	45	20	10	31	60	M38x1.5	3~M10	16.5
3U-208	210	137	92	170	133.4	5	52	23	11	31	80	M48x2	3~M12	18
3U-210	254	152	102	220	171.4	5	75	25	15	37	105	M68x2	3~M16	23
3U-212	304	157	102	220	171.4	5	100	25	15	37	135	M92x2	3~M16	26

Model	M	N	P	Q max.	Q min.	R	S	T	U(H6)	V	W max.	W min.	X
3U-203	12	26	M5	7.5	6.5	38	15	10	32	3.5	2	-2	M3
3U-204	17	40	M6	10.75	9.25	46	20	10	38	4	3	-3	M4
3U-205	20	41.5	M8	13.25	11.75	55	24	10	45	5	3	-3	M5
3U-206	30	50	M10	15.75	13.25	72	30	17	58	6	5	-5	M5
3U-208	34	63	M12	16.25	13.25	82	35	17	68	6	5	-7	M6
3U-210	39	74	M14	20.75	18.25	107	40	17	93	6	5	-5	M8
3U-212	44	74	M14	44.25	41.75	130	40	17	114	6	5	-5	M10



- Pin-Arbor Draw Down type 3-jaw non-thru-hole power chuck.
- High radial gripping force and high accuracy.
- Suitable for heavy machining.
- Can work with the airtight detection device to perform axial position confirm, suitable for the precision of large length size process.

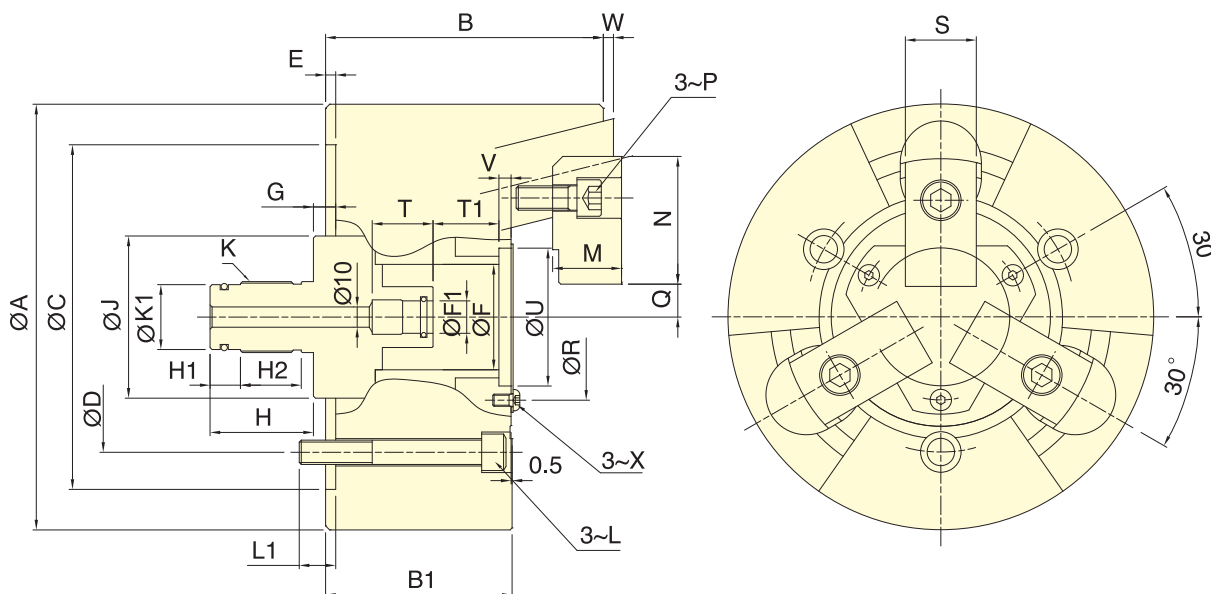

Subject to technical changes

SPECIFICATIONS

Model	Plunger stroke	Jaw stroke (Dia.)	Chucking Dia. Max.	Chucking Dia. Min.	Max. D.B. pull	Max. Clamping force	Max. speed	Moment of inertia	Weight	Matching cyl.	Max. pressure
	mm	mm	mm	mm	kN (kgf)	kN (kgf)	min ⁻¹ (r.p.m.)	kg · m ²	kg		MPa (kgf/cm ²)
3U-205K	6	3	84	15	13.9(1420)	39.7(4050)	8000	0.018	6.8	RL-100, RL-A100N	2.0(20)
3U-206K	10	5	105	24	17.9(1830)	57.8(5900)	7000	0.055	14.9	RL-100, RL-A100N	2.5(25)
3U-208K	12	6	132	25	25.0(2550)	80.0(8150)	6000	0.14	25.8	RL-125, RL-A125N	2.2(22)
3U-210K	10	5	163	34	31.0(3160)	100(10100)	4500	0.36	44.0	RL-125, RL-A125N	3.1(31)
3U-212K	10	5	210	81	35.0(3570)	100(10100)	3600	0.68	63.8	RL-125, RL-A125N	3.1(31)

DIMENSIONS

Model	A	B	B1	C(H6)	D	E	F	F1(H8)	G max.	G min.	H	H1	H2	J	K	K1	L
3U-205K	135	84.5	63	110	82.6	4	35	14	16	10	42	12	-	50	M25x1.5	22	M10
3U-206K	168	118	80	140	104.8	5	45	14	20	10	48	12	30	60	M28x1.5	24	M10
3U-208K	210	137	92	170	133.4	5	52	16	23	11	51	15	30	80	M35x1.5	30	M12
3U-210K	254	152	102	220	171.4	5	75	16	25	15	51	15	30	105	M38x1.5	34	M16
3U-212K	304	157	102	220	171.4	5	100	16	25	15	51	15	30	135	M45x1.5	40	M16

Model	L1	M	N	P	Q max.	Q min.	R	S	T	T1	U(H6)	V	W max.	W min.	X
3U-205K	15	20	41.5	M8	13.25	11.75	55	24	25	15.5	45	5	3	-3	M5
3U-206K	16.5	30	50	M10	15.75	13.25	72	30	30	26.5	58	6	5	-5	M5
3U-208K	18	34	63	M12	16.25	13.25	82	35	30	32.5	68	6	5	-7	M6
3U-210K	23	39	74	M14	20.75	18.25	107	40	30	36.5	93	6	5	-5	M8
3U-212K	26	44	74	M14	44.25	41.75	130	40	30	36.5	114	6	5	-5	M10



- Suitable for internal gripping.
- Radial clamp and axial pull down at the same time, keep the workpiece attaching close to the base surface of the chuck.
- Almost no workpiece uplifting displacement.
- With high precision and stability that chuck suitable for end process.
- Airtight pressure detect function is optional.

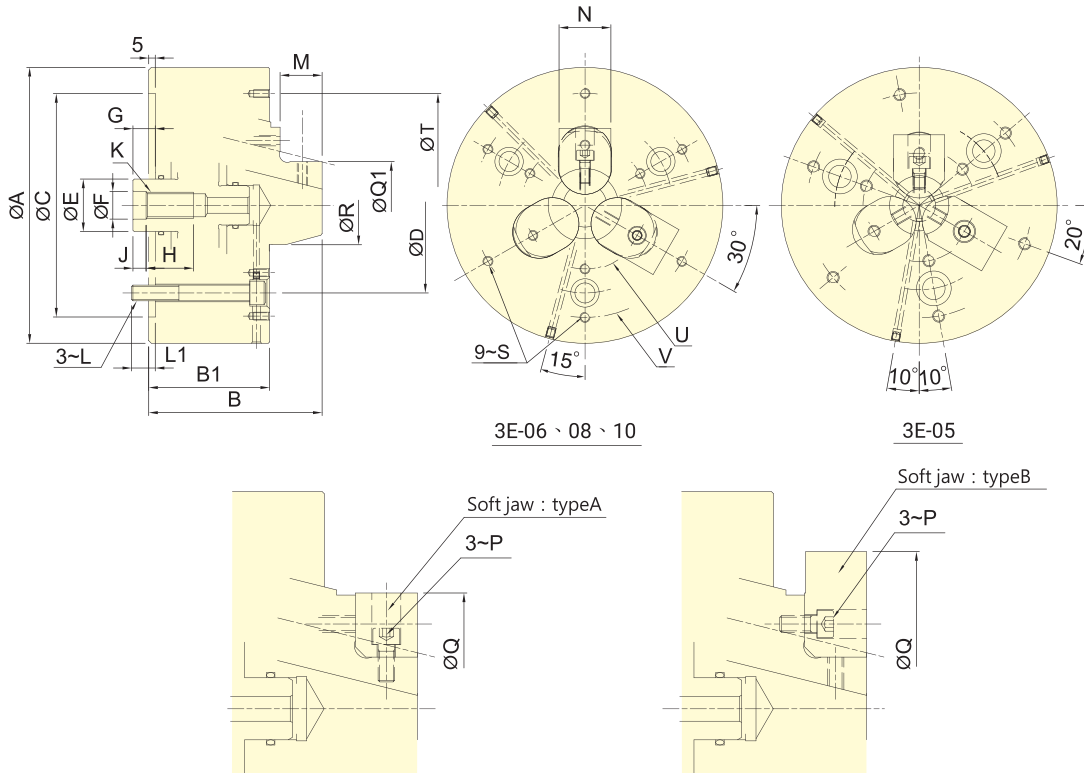

Subject to technical changes

SPECIFICATIONS

Model	Plunger stroke	Jaw stroke (Dia.)	Chucking Dia.Max.	Chucking Dia.Min.	Max. D.B. pull	Max. Clamping force	Max. speed	Moment of inertia	Weight	Matching cyl.	Max. pressure
	mm	mm	mm	mm	kN (kgf)	kN (kgf)	min ⁻¹ (r.p.m.)	kg · m ²	kg		MPa (kgf/cm ²)
3E-05	6	3	83	29	13.0(1325)	42.0(4280)	7000	0.018	7.5	RK-100	1.8(18.5)
3E-06	10	5	110	44	18.0(1835)	58.0(5910)	6000	0.042	13.6	RK-100	2.5(25.6)
3E-08	10	5	150	50	25.0(2530)	80.0(8150)	5000	0.14	26.5	RK-125	2.2(22.5)
3E-10	10	5	190	60	35.0(3570)	100.0(10200)	3600	0.31	39.5	RK-150	2.8(28.5)

DIMENSIONS

Model	A	B	B1	C (H6)	D	E	F (H8)	G		H	J	K	L	L1
								max.	min.					
3E-05	135	98	72	110	82.6	25	18	18	12	25	8	M16	M10	15
3E-06	165	112	80	140	104.8	35	18	22	12	30	8	M16	M10	16
3E-08	210	135	90	170	133.4	40	21	22	12	36	10	M20	M12	18
3E-10	254	152	102	220	171.4	50	25	25	15	48	10	M24	M16	23

Model	M	N	P	type A		type B		Q1		R	S	T	U (p.c.d)	V (p.c.d)
				Q max.	Q min.	Q max.	Q min.	max.	min.					
3E-05	20	25	M6	68	50	83	67	50	29	25	M6x12	110	55	110
3E-06	23	31	M6	90	70	110	89	70	44	40	M6x12	130	76	134
3E-08	30	35	M8	110	90	150	108	90	50	49	M6x12	170	100	170
3E-10	35	40	M10	127	110	190	125	110	60	59	M8x16	210	120	210



SPECIAL PURPOSE POWER CHUCKS

- Swing and grasp the workpiece to three jaw. (3W is automatically positioned to the center type.)
- Suitable for such materials as the casting and forging to process.
- Suitable for heavy machining.
- Seal proof for dust and cutting fluid, it is more convenient when maintenance.
- Swing parts are to heat treatment hardened and ground for steel, in order to improve products service life.
- Swing and grasp the workpiece to three jaw.(3W-C is center compensation type.)
- The workpieces compensation of eccentric is 2 mm, fixed position for the center thimble.

- Carbide gripper is optional. * The type of the carbide gripper is selected according to the work-piece conditions.
- According to different processing requirements, O.D. Gripping and I.D. Gripping can be interchanged.

Type of the Carbide gripper

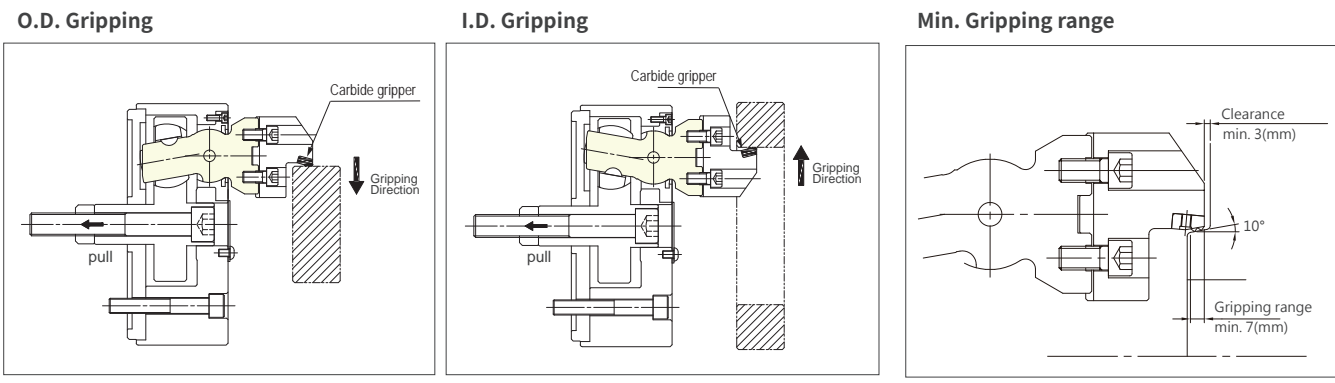
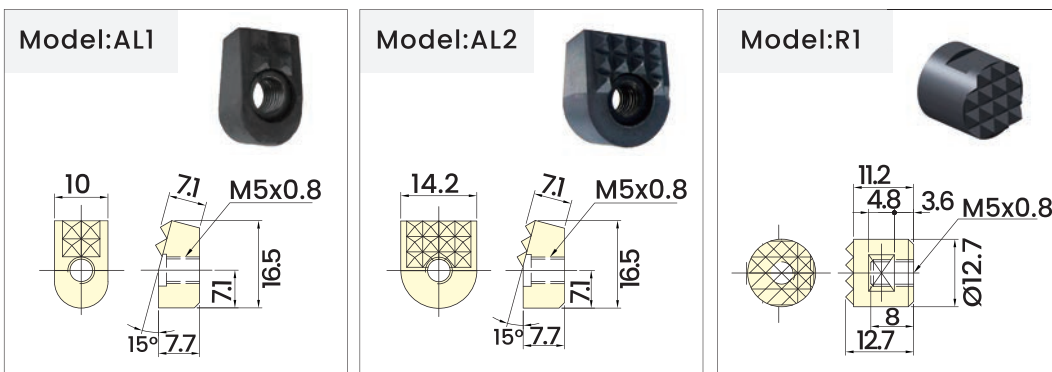

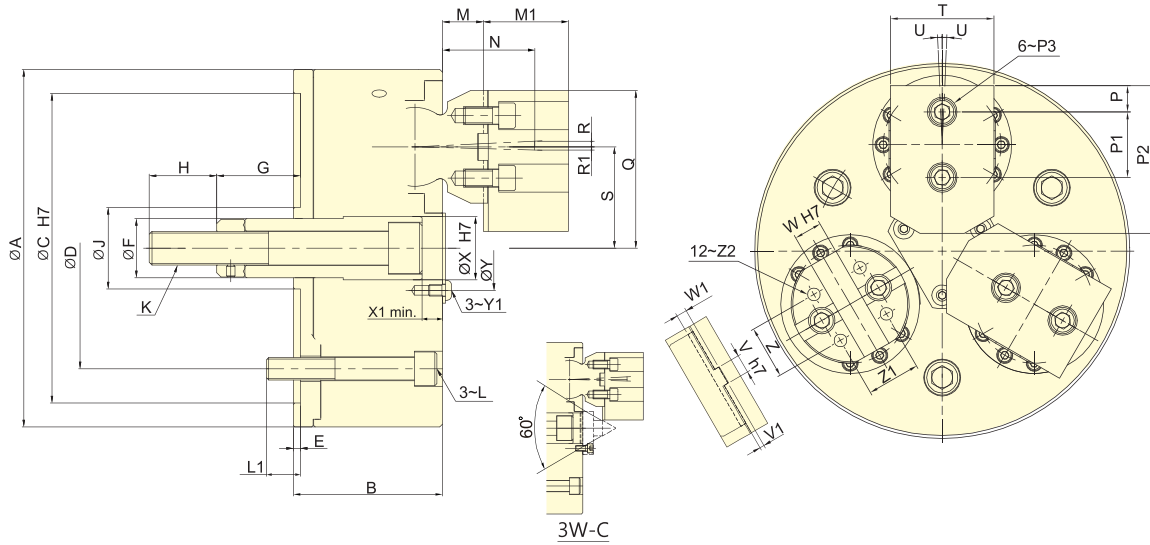

Subject to technical changes

SPECIFICATIONS

Model	Plunger stroke	Jaw stroke (Dia.)	Chucking O.D.	Chucking I.D.	Max. D.B. pull	Max. clamping force	Max. speed	Moment of inertia	Weight	Matching cyl.	Compensation
	mm	mm	Min.-Max.	Min.-Max.							
3W-08	14.4	9.8	16~150	76~203	25(2550)	85.0(8670)	3700	0.12	23	RK-100(N)	-
3W-C08	14.4	9.8	16~150	76~203	25(2550)	85.0(8670)	3700	0.12	23	RK-100(N)	2
3W-10	17.5	12.5	50~205	85~235	35.3(3600)	105.9(10800)	2500	0.37	48.6	RK-125(N)	-
3W-C10	17.5	12.5	50~205	85~235	35.3(3600)	105.9(10800)	2500	0.37	48.6	RK-125(N)	2
3W-12	17.5	12.5	63~240	127~305	35.3(3600)	105.9(10800)	2400	0.73	65	RK-125(N)	-
3W-C12	17.5	12.5	63~240	127~305	35.3(3600)	105.9(10800)	2400	0.73	65	RK-125(N)	2
3W-15	22.5	15.9	76~317	165~381	56(5600)	168.2(16800)	2000	1.81	97	RK-150(N)	-
3W-C15	22.5	15.9	76~317	165~381	56(5600)	168.2(16800)	2000	1.81	97	RK-150(N)	3

DIMENSIONS

Model	A	B	C (H7)	D	E	F	G max.	G min.	H	J	K	L	L1	M	M1	N	P	P1	P2
3W-08	210	89	170	133.4	5	34	51.9	37.5	40	50	M18x2.5	M12	19	19.3	56.5	52.7	16	38	80
3W-C08	210	89	170	133.4	5	34	51.9	37.5	40	50	M18x2.5	M12	19	19.3	56.5	52.7	16	38	80
3W-10	254	106	220	171.4	5	42	67.5	50	48	58	M24x3	M16	24	29	60.5	65.6	17.8	44.4	100
3W-C10	254	106	220	171.4	5	42	67.5	50	48	58	M24x3	M16	24	29	60.5	65.6	17.8	44.4	100
3W-12	304	106	220	171.4	5	42	67.5	50	48	58	M24x3	M16	24	29	60.5	65.6	17.8	44.4	100
3W-C12	304	106	220	171.4	5	42	67.5	50	48	58	M24x3	M16	24	29	60.5	65.6	17.8	44.4	100
3W-15	381	120	300	235	5	55	62.5	40	46	80	M27x3	M20	30	32.4	72	74.3	19	63.5	140
3W-C15	381	120	300	235	5	55	62.5	40	46	80	M27x3	M20	30	32.4	72	74.3	19	63.5	140

Model	P3	Q	R	RI	S	T	U	V (h7)	V1	W (H7)	W1	X(H7)	X1	Y	Y1	Z	Z1	Z2
3W-08	M12	95	2.69	2.24	60	57	2	7.94	3	12.68	7	34	3.5	46	M6	32	32	M10
3W-C08	M12	95	2.69	2.24	60	57	2	7.94	3	12.68	7	34	3.5	46	M6	32	32	M10
3W-10	M12	112	4.03	2.26	72	70	2.5	12.7	3	19.03	7	45	5	60	M8	36	36	M10
3W-C10	M12	112	4.03	2.26	72	70	2.5	12.7	3	19.03	7	45	5	60	M8	36	36	M10
3W-12	M12	132.5	4.03	2.26	92.5	70	2.5	12.7	3	19.03	7	45	5	60	M8	36	36	M10
3W-C12	M12	132.5	4.03	2.26	92.5	70	2.5	12.7	3	19.03	7	45	5	60	M8	36	36	M10
3W-15	M12	172	5.14	2.83	121	80	2	12.7	3	19.03	7	56	3	90	M8	36	36	M10
3W-C15	M12	172	5.14	2.83	121	80	2	12.7	3	19.03	7	56	3	90	M8	36	36	M10



- The workpieces compensation of eccentric is 2 mm, fixed position for the center thimble, swing and grasp the workpiece to three jaw.
- Special seal proof for dust and cutting fluid, it is more convenient when maintenance.
- Swing parts are to heat treatment hardened and ground for steel, in order to improve products service life.

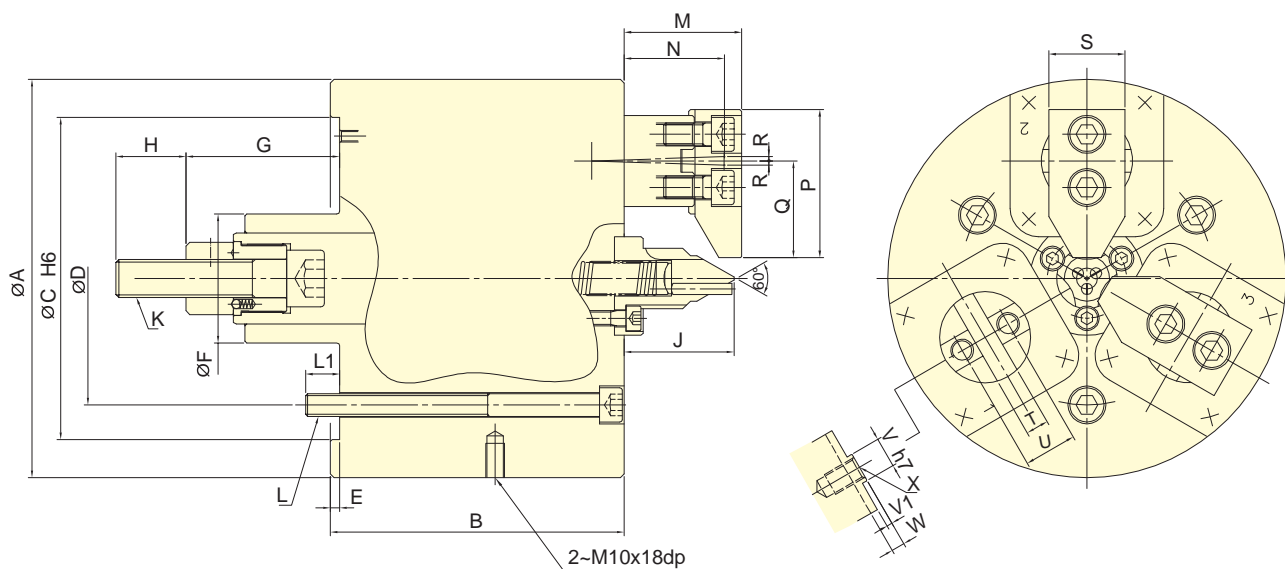

Subject to technical changes

SPECIFICATIONS

Model	Chucking Dia.	Jaw stroke (Dia.)	Chucking Dia. Max.	Chucking Dia. Min.	Max. D.B. pull	Max. clamping force	Max. speed	Moment of inertia	Weight	Matching cyl.	Compensation
	mm	mm	mm	mm	kN (kgf)	kN (kgf)	min ⁻¹ (r.p.m.)	kg · m ²	kg		mm
3RF-08	43.5	9.4	70	18	39.2(4000)	39.2(4000)	4000	0.15	30	RS-1250	1

DIMENSIONS

Model	A	B	C	D	E	F	G max.	G min.	H	J	K	L	L1	L1
3RF-08	210	155	170	133.4	5	68	123	79.5	37	58	M20x2.5	3-M12	18	20

Model	M	N	P	Q	R	S	T(H7)	U	V	V1	W	X	W	W1	X
3RF-08	62	53	78	51	2.2	40	12	28	16	3	7	M12	35	7	M12

1. Clamping diameter machining

The compensating jaws are retracted. The workpiece is clamped between chuck center and tailstock center. Additionally, it is driven by the face driver.

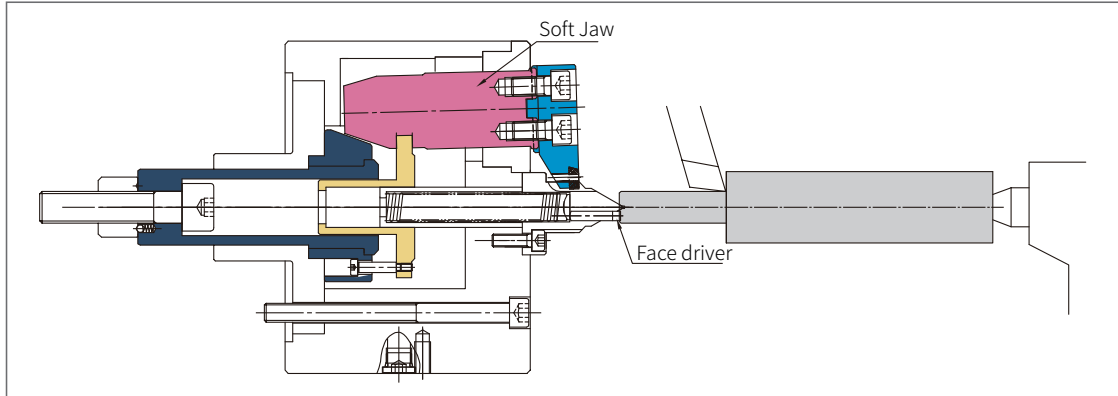

2. Rough machining

With compensating jaws clamping, the rough machining can be carried out.

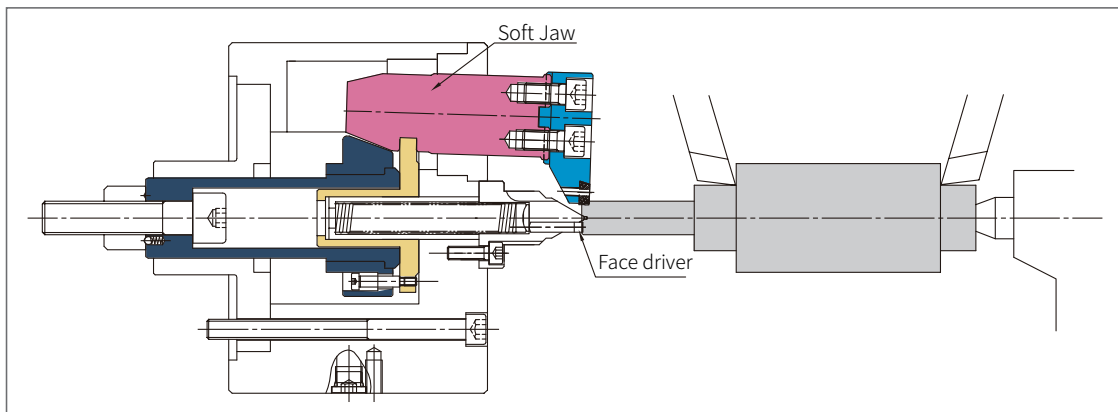

3. Finish machining

Additionally, it is driven by the face driver.

The entire workpiece can be machined with precise concentricity.

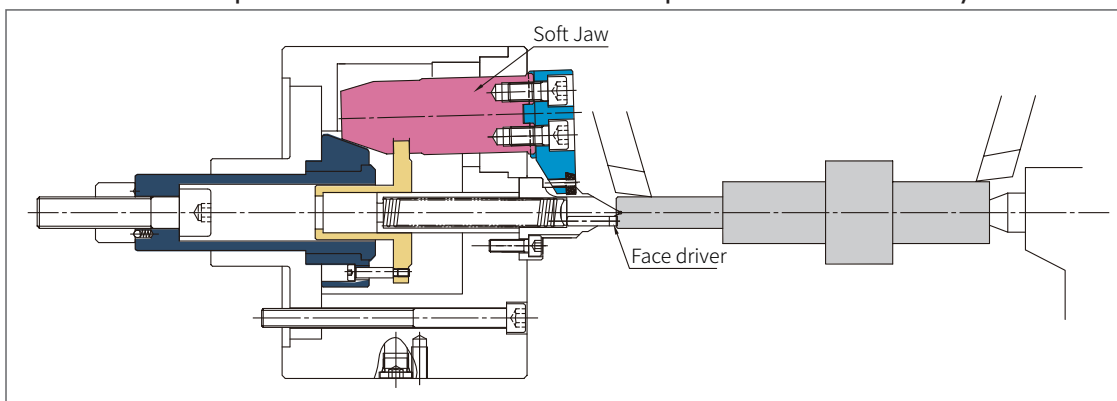



- The workpieces compensation of eccentric is 2 mm, fixed position for the center thimble, swing and grasp the workpiece to three jaw.
- Special seal proof for dust and cutting fluid, it is more convenient when maintenance.
- Swing parts are to heat treatment hardened and ground for steel, in order to improve products service life.

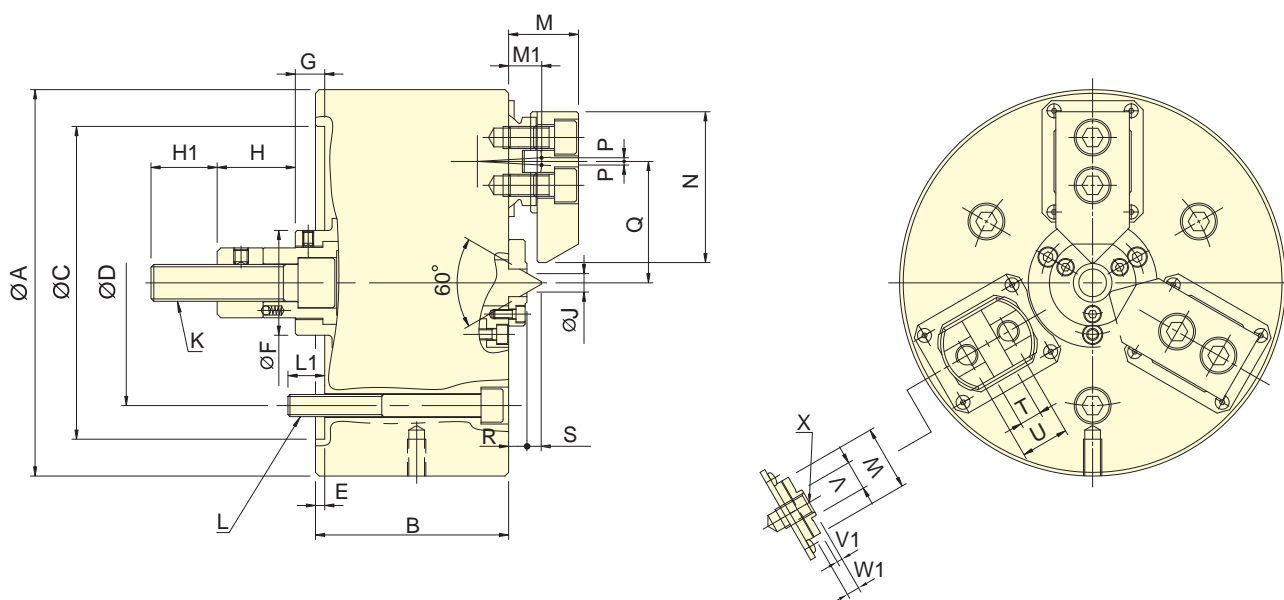

Subject to technical changes

SPECIFICATIONS

Model	Chucking Dia.	Jaw stroke (Dia.)	Chucking Dia. Max.	Chucking Dia. Min.	Max. D.B. pull	Max. clamping force	Max. speed	Moment of inertia	Weight	Matching cyl.	Compensation
	mm	mm	mm	mm	kN (kgf)	kN (kgf)	min ⁻¹ (r.p.m.)	kg · m ²	kg		mm
3R-08	20	8	65	18	19.6(2000)	53.0(5404)	2800	0.15	27	RK-100N	2
3R-10	25	10	90	22	29.4(3000)	67.7(6901)	2500	0.38	45	RK-125N	2

DIMENSIONS

Model	A	B	C (H6)	D	E	F	G max.	G min.	H	H1	J	K	L	L1
3R-08	210	105	170	133.4	5	57	26	6	42.5	36	10.4	M20x2.5	3-M12	20
3R-10	254	115	220	171.4	5.5	64	36.5	11.5	25	39	15	M20x2.5	3-M16	22.5

Model	M	M1	N	P	Q max.	Q min.	R	S	T (H7)	U	V	V1	W	W1	X
3R-08	38	18	82	2	68	64	10	7.7	12	26	16	3	35	7	M12
3R-10	40	19	102	2.6	82	78	10	11.3	15	32	18	3	40	7	M14



- Gripping at the end face and preventing deformation of workpiece.
- Suitable for thin wall workpiece processing.
- The gripping compensating mechanism can grasp the irregular surface workpieces well.
- Airtight pressure detect function is optional.

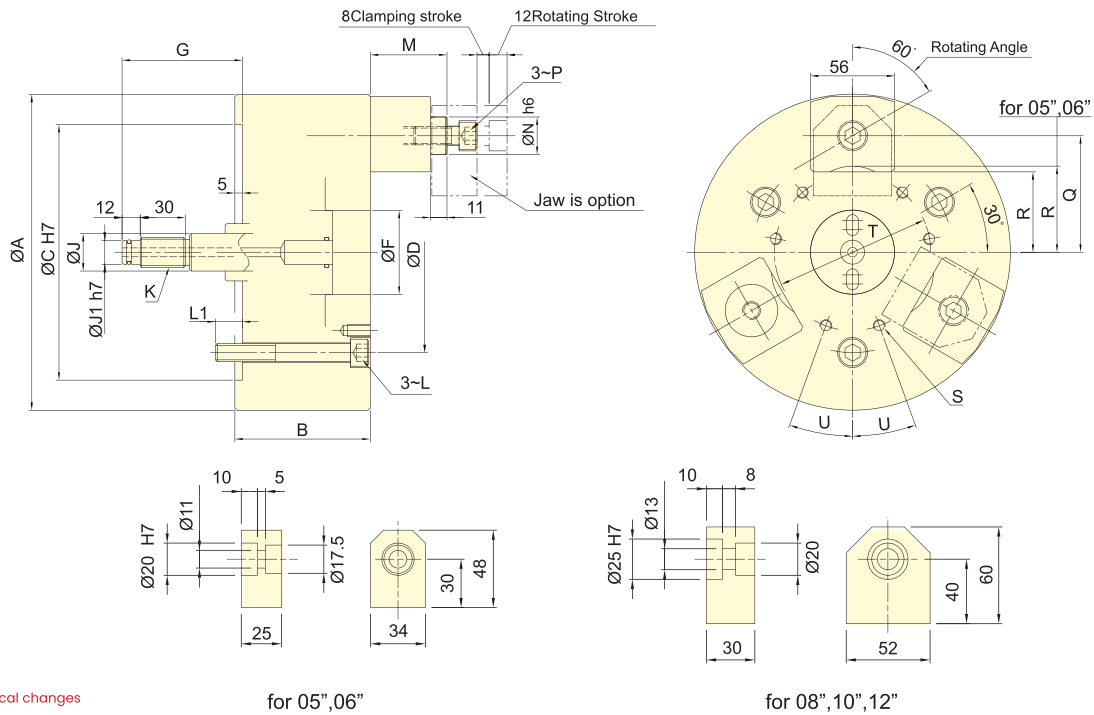

Subject to technical changes

SPECIFICATIONS

Model	Rotating stroke	Clamping stroke	Jaw's compensation	Chucking Dia.Max.	Chucking Dia.Min.	Max. D.B. pull	Max. Clamping force	Max. speed	Moment of inertia	Weight	Matching cyl.	Max. pressure
	mm	mm	mm	mm	mm	kN (kgf)	kN (kgf)	min ⁻¹ (r.p.m.)	kg · m ²	kg		MPa (kgf/cm ²)
3J-05	12	8	2	53	25	7.5(765)	6.0(612)	4000	0.02	11.0	RK-100 OR RK-100(N)	1.0(10)
3J-06	12	8	2	79	55	9.0(918)	7.5(765)	4000	0.04	12.0	RK-100 OR RK-100(N)	1.2(12)
3J-08	12	8	2	106	75	18.0(1835)	16.5(1680)	3500	0.13	23.0	RK-100 OR RK-100(N)	2.5(25)
3J-10	12	8	2.5	150	119	18.0(1835)	16.5(1680)	3500	0.30	33.0	RK-100 OR RK-100(N)	2.5(25)
3J-12	12	8	2.5	200	169	18.0(1835)	16.5(1680)	3000	0.56	44.0	RK-100 OR RK-100(N)	2.5(25)

DIMENSIONS

Model	A	B	C	D	F	G max.	G min.	J	J1	K
3J-05	135	86	110	82.6	40	75	55	25	9	M12x1.75
3J-06	165	86	140	104.8	45	75	55	28	12	M16x2
3J-08	210	90	170	133.4	56	80	60	38	16	M20x2.5
3J-10	254	95	220	171.4	56	75	55	38	16	M20x2.5
3J-12	304	95	220	171.4	56	75	55	38	16	M20x2.5

Model	L	L1	M max.	M min.	N	P	Q	R	S	T	U
3J-05	M10	15	56	36	20	M10	42.5	27	3~M6	50	-
3J-06	M10	15	56	36	20	M10	57.5	40	3~M8	64	-
3J-08	M12	18	71	51	25	M12	77.5	53.5	6~M8	104	20 °
3J-10	M16	24	71	51	25	M12	99.5	75.5	6~M8	140	20 °
3J-12	M16	24	71	51	25	M12	124.5	100.5	6~M8	190	20 °



- Gripping at the end face and preventing deformation of workpiece.
- Suitable for thin wall workpiece processing.
- The gripping compensating mechanism can grasp the irregular surface workpieces well.
- Airtight pressure detect function is optional.

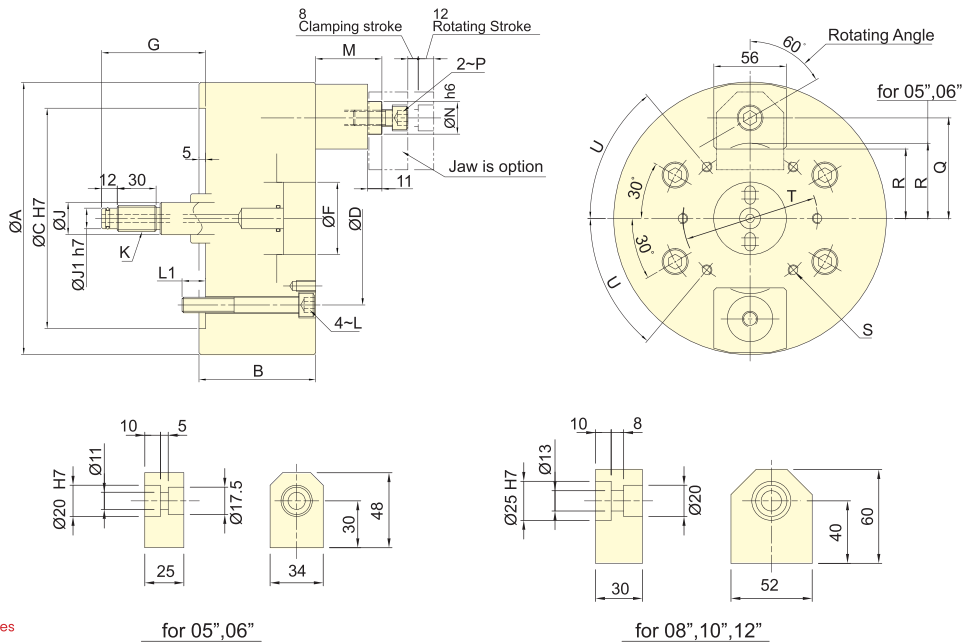

Subject to technical changes

SPECIFICATIONS

Model	Rotating stroke	Clamping stroke	Jaw's compensation	Chucking Dia. Max.	Chucking Dia. Min.	Max. D.B. pull	Max. Clamping force	Max. speed	Moment of inertia	Weight	Matching cyl.	Max. pressure
	mm	mm	mm	mm	mm	kN (kgf)	kN (kgf)	min ⁻¹ (r.p.m.)	kg · m ²	kg		MPa (kgf/cm ²)
2J-05	12	8	2	53	25	5.0(510)	4.0(408)	4000	0.015	9.0	RK-100 OR RK-100(N)	0.7(7)
2J-06	12	8	2	79	55	6.0(612)	5.0(510)	4000	0.035	9.8	RK-100 OR RK-100(N)	0.8(8)
2J-08	12	8	2	106	75	12.0(1224)	11.0(1122)	3500	0.12	20.3	RK-100 OR RK-100(N)	1.7(17)
2J-10	12	8	2.5	150	119	12.0(1224)	11.0(1122)	3500	0.28	30.7	RK-100 OR RK-100(N)	1.7(17)
2J-12	12	8	2.5	200	169	12.0(1224)	11.0(1122)	3000	0.52	41.2	RK-100 OR RK-100(N)	1.7(17)

DIMENSIONS

Model	A	B	C	D	F	G max.	G min.	J	J1	K
2J-05	135	86	110	82.6	40	75	55	25	9	M12x1.75
2J-06	165	86	140	104.8	45	75	55	28	12	M16x2
2J-08	210	90	170	133.4	56	80	60	38	16	M20x2.5
2J-10	254	95	220	171.4	56	75	55	38	16	M20x2.5
2J-12	304	95	220	171.4	56	75	55	38	16	M20x2.5

Model	L	L1	M max.	M min.	N	P	Q	R	S	T	U
2J-05	M10	15	56	36	20	M10	42.5	27	4~M6	50	30 °
2J-06	M10	15	56	36	20	M10	57.5	40	4~M8	64	30 °
2J-08	M12	18	71	51	25	M12	77.5	53.5	6~M8	104	50 °
2J-10	M16	24	71	51	25	M12	99.5	75.5	6~M8	140	50 °
2J-12	M16	24	71	51	25	M12	124.5	100.5	6~M8	190	50 °

SPECIAL PURPOSE POWER CHUCKS

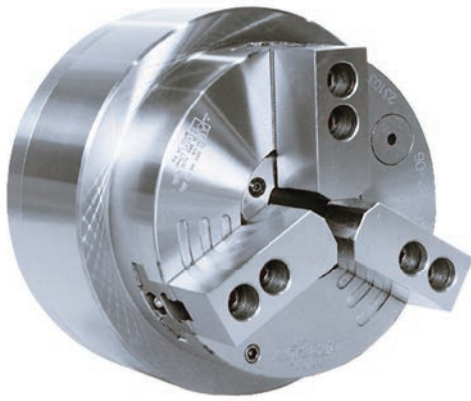

- Large through-hole 3-jaw power chuck with built in air cylinder.
- Patented air supply system, it is easy to install and maintain. No abrasion issue of traditional sealed ring. Maintenance cost and time can be saved.

■ Patent numbers :
 20.2011.101.818.4 / 20.2012.102.498.5 (Germany)
 3169457 / 3178706 (Japan) / EP 2517822 B1 (EU)
 ZL 2011 2 0141324.9 / ZL 2012 2 0274549.6 (China)
 M440159 / M415011 (Taiwan) / US8770222 B2 (U.S.A.)
 0000278076 (Italy)

SPECIAL PURPOSE POWER CHUCKS

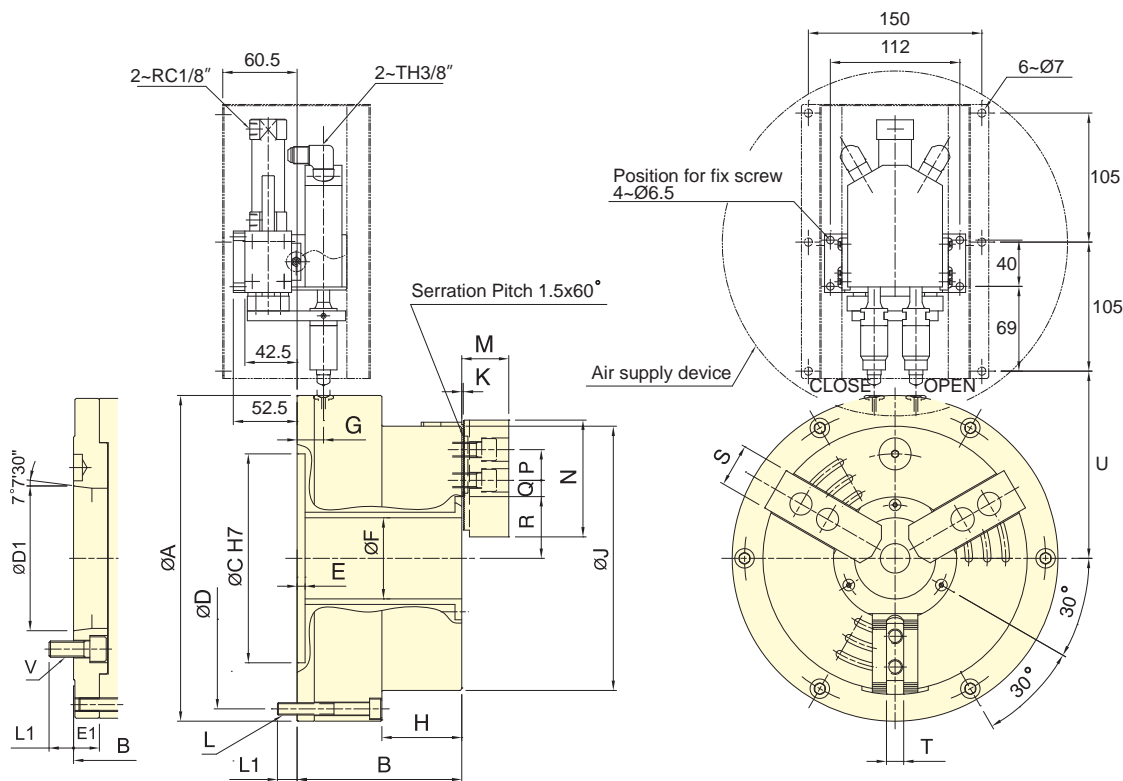

AP-A

Subject to technical changes

SPECIFICATIONS

Model	Thru-hole Dia.	Jaw stroke	Chucking Dia. Max.	Chucking Dia. Min.	Max. pressure	Max. Clamping force	Max. speed	Moment of inertia	Weight	Air Consumption		
		mm	mm	mm	mm	MPa (kgf/cm ²)	kN (kgf)	min ⁻¹ (r.p.m.)	kg · m ²	kg	lit (at 6kgf/cm ²)	
AP-52	A6	52	5.9	170	15	0.6(6.1)	40.5(4128)	3900	0.2	26	30	3.1
AP-66	A6	66	7.6	215	24	0.6(6.1)	50(5097)	3000	0.4	38	45	5.1
AP-86	A8	86	8.9	268	43	0.6(6.1)	80(8156)	2800	0.7	58	72	8.7
AP-115	A8	115	10.6	330	55	0.6(6.1)	90(9174)	2000	1.7	92	112	12

DIMENSIONS

Model	A	B	C	D	D1	E	E1	F	G	H	J	K	L		
AP-52	A6	235	121	140	170	215	106.38	6.5	19	52	21.5	58.5	170	2	6~M10
AP-66	A6	265	134	153	170	245	106.38	6.5	19	66	21.5	65	215	2	6~M10
AP-86	A8	315	142	169	220	295	139.72	6.5	27	86	21.5	67	268	2	6~M10
AP-115	A8	370	154	181	220	350	139.72	6.5	27	115	21.5	69	330	2	6~M10

Model	L1	M	N	P	Q max.	Q min.	R max.	R min.	S	T	U	V		
AP-52	A6	15	18	37	73	20	21.2	9.2	38	35.1	31	12	145.5	6~M12
AP-66	A6	16	18	38	95	25	23.7	8.7	50.2	46.4	35	14	159.5	6~M12
AP-86	A8	16	24	43	110	30	32.2	12.7	62.2	57.8	40	16	184.5	6~M16
AP-115	A8	16	24	51	130	30	44.7	14.7	77	71.7	50	21	212	6~M16

1. The dimensions and the specifications of AP-A type are in red data.



- Large through-hole 3-jaw power chuck with build in air cylinder.
- With build-in "pressure detection" device in chuck which can check the pressure is lowered rapidly within the chuck, guarantee to the security of operating.
- Patented air supply system, it is easy to install and maintain. No abrasion issue of traditional sealed ring. Maintenance cost and time can be saved.

■ Patent numbers :
 20.2011.101.818.4 / 20.2012.102.498.5 (Germany)
 3169457 / 3178706 (Japan) / EP 2517822 B1 (EU)
 ZL 2011 2 0141324.9 / ZL 2012 2 0274549.6 (China)
 M440159 / M415011 (Taiwan) / US8770222 B2 (U.S.A.)
 0000278076 (Italy)

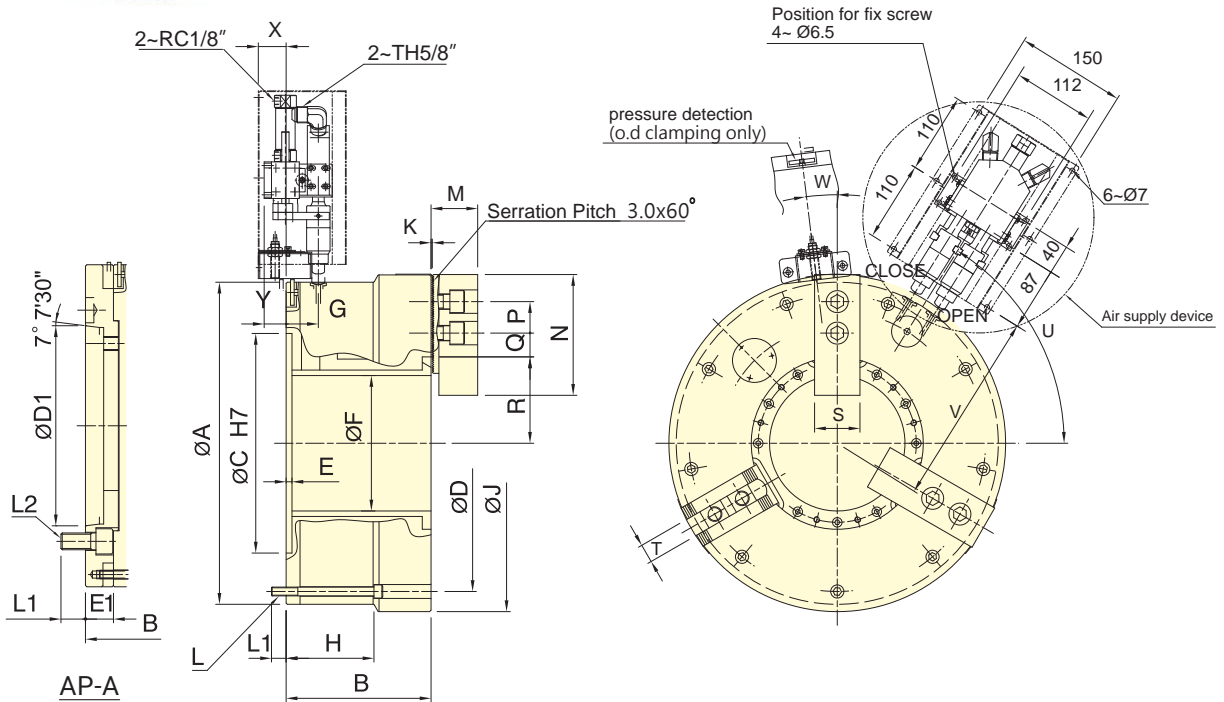

Subject to technical changes

SPECIFICATIONS

Model	Thru-hole Dia.	Jaw stroke (Dia.)		Chucking Dia. Max.	Chucking Dia. Min.	Max. pressure	Max. Clamping force	Max. speed	Moment of inertia	Weight	Air Consumption	
		mm	mm	mm	mm	MPa (kgf/cm ²)	kN (kgf)	min ⁻¹ (r.p.m.)	kg · m ²	kg	lit(at 6kgf/cm ²)	
AP-145	A11	145	14	420	62	0.6(6.1)	110(11213)	1500	3.8	156	182	17.8
AP-185	A15	185	14	460	100	0.6(6.1)	160(16310)	1700	6.0	188	223	22
AP-230	A15	230	17	535	170	0.6(6.1)	150(15290)	1300	11.1	265	310	34
AP-275	A20	275	17	580	200	0.6(6.1)	160(16310)	1100	15.5	301	346	39
AP-320	A20	320	17	658	200	0.6(6.1)	180(18348)	1000	27.2	415	505	45
AP-375	A20	375	24	738	260	0.6(6.1)	210(21406)	900	44.2	530	545	55

DIMENSIONS

Model	A	B	C	D	D1	E	E1	F	G	H	J	K	L	L1			
AP-145	A11	400	198	231	300	365	196.87	8	33	145	34	120	420	3.5	9~M12	20	31
AP-185	A15	460	198	238	300	405	285.78	8	40	185	44	120	460	3.5	9~M12	20	35
AP-230	A15	515	226	266	380	483	285.78	8	40	230	49	145	535	3.5	6~M16	24	35
AP-275	A20	560	232	272	380	528	412.78	8	40	275	52	152	580	3.5	6~M16	24	35
AP-320	A20	615	256	306	520	580	412.78	8	50	320	55	116.5	658	3.5	9~M16	25	33
AP-375	A20	690	272	322	520	650	412.78	8	50	375	55	127	738	3.5	9~M16	28	33

Model	L2	M	N	P	Q max.	Q min.	R max.	R min.	S	T	U	V	W	X	Y	
AP-145	A11	6~M20	63.7	165	43	53.5	23.5	98	91	62	25.5	57°	242	0°	38	20
AP-185	A15	6~M24	63.7	165	43	53.5	23.5	118	111	62	25.5	58°	272	7°	38	20
AP-230	A15	6~M24	71.7	180	60	48.5	18.5	145	136.5	64	25.5	30°	300	7°	33	15
AP-275	A20	6~M24	71.7	180	60	48.5	18.5	167.5	159	64	25.5	30°	322	7°	30	12
AP-320	A20	6~M24	81.5	210	60	60.5	24.5	190	181.5	74	30	52°	350	7°	27	9
AP-375	A20	6~M24	81.5	210	60	66.5	24.5	223.5	211.5	74	30	52°	387	7°	27	9

1. The dimensions and the specifications of AP-A type are in red data.



- Large through-hole 3-jaw power chuck with build in air cylinder.
 - With build-in "pressure detection" device which can check the rapidly decreasing pressure within the chuck, guarantee to the security when operating.
 - Patented air supply system, it is easy to install and maintain. No abrasion issue of traditional sealed ring. Maintenance cost and time can be saved.
 - The build-in "clamping detection" device can avoid jaws clamping the workpiece during the rapid stroke stage. This mechanism can also prevent causing the damage of the internal parts or flying out of workpiece.(only for external clamping)
 - Extended jaw stroke design can shorten the processing time when gripping.
- Notice:No clamping in rapid stroke period.

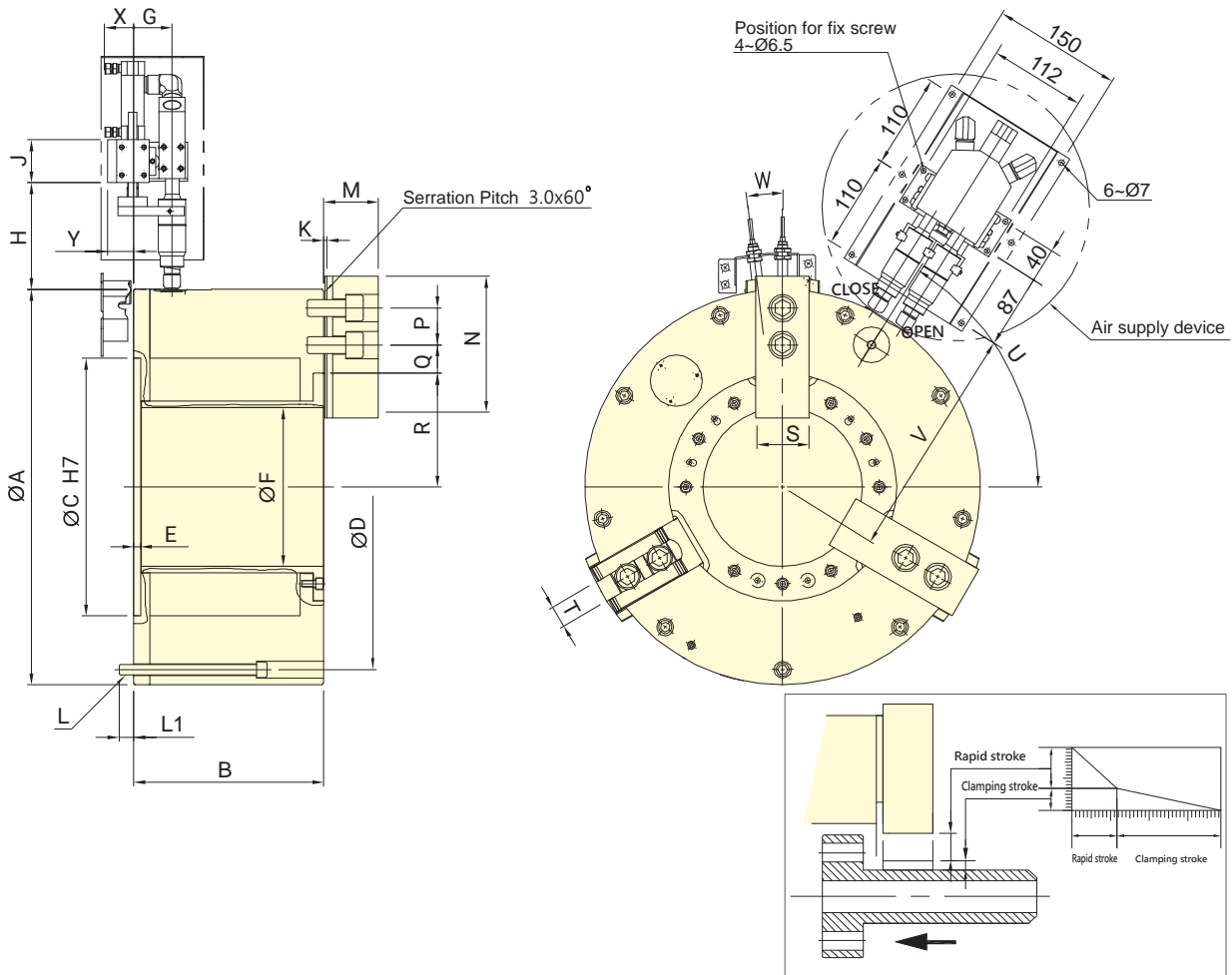

Subject to technical changes

SPECIFICATIONS

Model	Thru-hole Dia.		Jaw stroke (Dia.)		Chucking Dia. Max.	Chucking Dia. Min.	Max. Clamping force	Max. speed	Moment of inertia	Weight	Air Consumption
	mm	mm	mm	mm	mm	mm	kN (kgf)	min ⁻¹ (r.p.m.)	kg · m ²	kg	lit(at 6kgf/cm ²)
APS-185	185	26	14	460	127	110(1216)	1300	6.45	198	22	

DIMENSIONS

Model	A	B	C	D	E	F	G	H	J	K	L	L1	M
APS-185	460	221	300	425	8	185	45	124	50	3.5	9~M12	17	63.7
Model	N	P	Q max.	Q min.	R max.	R min.	S	T	U	V	W	X	Y
APS-185	165	43	37	17	145	125	62	25.5	58	272	7°	38	30



- Indexing operates during the spindle rotation, can perform a quick change between multiple working axes.
- All parts of chuck hardened, ground and lubricated directly.
- Sealed against swarf, chips and coolant.
- High rigidity and high repeatability precision.
- Unique indexing system and hydraulic system, with pressure detection device in chuck, high reliability.

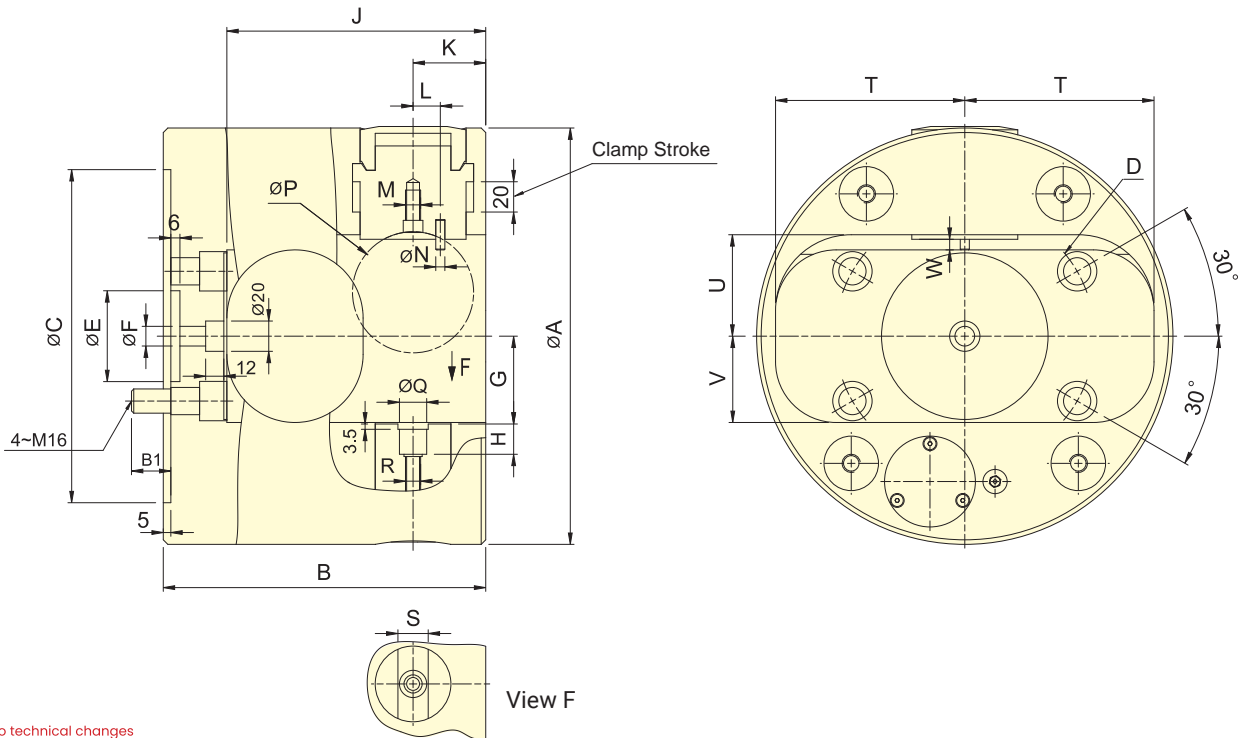

Subject to technical changes

SPECIFICATIONS

Model	Index Angle	Jaw stroke	Chucking Area Dia Max.	Chucking Area Len Max.	Max. pressure	Max. Clamping force	Max. speed	Moment of inertia	Weight	ROTATING JOINT	Main Spindle Bore
	Deg	mm	mm	mm	kgf/cm ²	kN (kgf)	min ⁻¹ (r.p.m.)	kg · m ²	kg		mm
IS-254	4x90°	20	65	160	45	19.5(1990)	2400	0.41	41	IS-315	86+0.1
IS-275	4x90°	20	80	220	45	25.4(2590)	2100	0.61	52	IS-315	86+0.1
IS-315	4x90°	20	100	230	45	25.0(2550)	1800	1.13	76	IS-315	86+0.1

DIMENSIONS

Model	A	B	B1	C(H6)	D	E	F	G	H	J	K
IS-254	254	190	23	220	171.4	60	13	47.5	18	155	48
IS-275	275	213	26	220	171.4	60	13	58	20	171	48
IS-315	315	232	22	220	171.4	60	13	71	18.5	187	50

Model	L	M	N	P	Q(H7)	R	s(H7)	T	U	V	W
IS-254	13	M8	5	40	18	M10	20	106	57	46.5	5.5
IS-275	18	M10	6	80	18	M10	20	125	67	57	7
IS-315	18	M10	6	75	24	M12	25	125	85	70	7.5

*Index Angle 8x45° or Specific Angle, Please contact AUTOGRIP for more detailed information.Thanks.



- Rotary chuck with built-in pneumatic cylinder, compact design, suitable for light machining, compatible to standard soft jaw/ hard jaw.
 - Can be installed on a rotary table for indexing machining.
 - Sealed against dust and cutting chips.
 - Matching surfaces of all parts hardened, ground and lubricated directly.
- Note: To overcome friction force between distributor ring and chuck body, the rotating torque of rotary table must be higher than the requirement shown in the table.

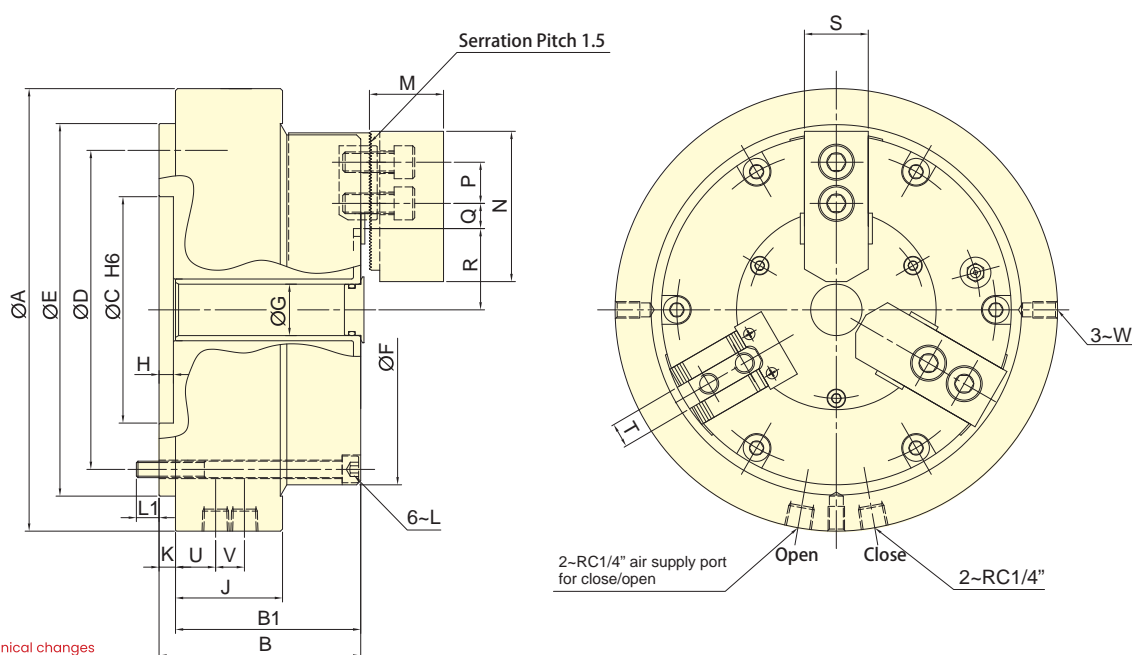

Subject to technical changes

SPECIFICATIONS

Model	Jaw stroke (Dia.)	Chucking Dia. Max.	Chucking Dia. Min.	Max. clamping force Pneumatic (at 6.0kgf/cm ²)	Max. pressure	Max. speed	Max Rotation resistance torque	Air consumption (at 6.0 kgf/cm ²)	Weight
	mm	mm	mm	kN (kgf)	(kgf/cm ²)	(r.p.m.)	Nm	lit (kgf/cm ²)	kg
RAP-306	5.5	170	25	21.0(2141.4)	7	72	40	3.1	16.2
RAP-308	6.8	215	37	34.2(3487.4)	7	60	60	3.1	30.6
RAP-310	7	254	53	48.0(4894.7)	7	53	85	4.2	42.4

DIMENSIONS

Model	A	B	B1	C (H6)	D	E	F	G	H	J	K
RAP-306	215	98	90	110	155	181	170	25	7	52	8
RAP-308	260	113	104	110	200	226	215	32	8	52	9
RAP-310	300	117	52	140	235	261	254	54	8	52	10

Model	L	L1	M	N	P	Q max.	Q min.	R max.	R min.	S	T	U	V	W
RAP-306	6~M8	11	36	73	20	10.75	4.75	39.5	36.75	31	12	19.5	14	3~M8
RAP-308	6~M8	16	37	95	25	13.25	8.75	57	53.6	35	14	19.5	14	3~M8
RAP-310	6~M8	14	42	110	30	23.25	12.75	64.5	61	40	16	19.5	14	3~M8



- PUSH type collet used mainly on turning, CNC, special purpose machines , ect.
- High clamping accuracy, high speed and high rigidity.
- The installation is the same as "Thru-hole power chuck" and they are replaceable with each other.
- Sealed against swarf, chips and coolant.
- The collet used must accord with DIN 6343.
- Patent numbers :
 PAT.NO.M380842(Taiwan)
 PAT.NO.ZL201020113762.X(China)

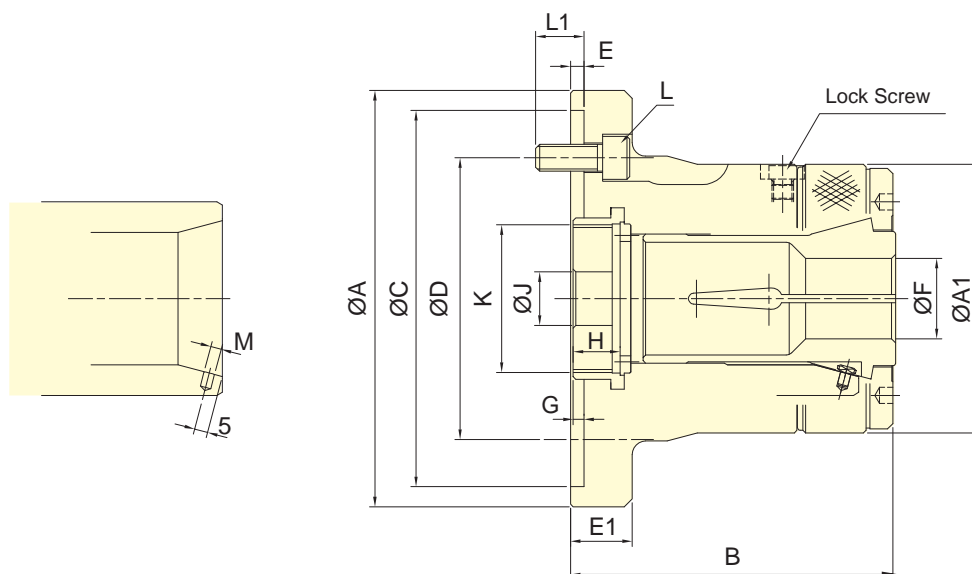

Subject to technical changes

SPECIFICATIONS

Model	Plunger stroke mm	Max. Chucking Capacity			Max. D.B. pull kN (kgf)	Max. clamping force kN (kgf)	Max. speed min ⁻¹ (r.p.m.)	Mo-ment of inertia kg · m ²	Weight kg	Matching steel collet	Matching Cyl.	Max. pressure
		Round mm	Hexagom mm	Square mm								MPa (kgf/cm ²)
CL-26	4.5	3~26	4~22	4~18	17.6(1800)	37.9(3870)	8000	0.040	4.3	161E	TK-A533	2.4(24)
CL-30	4.5	3~30	4~26	4~20	19.6(2000)	42.1(4300)	8000	0.038	4.2	163E	TK-A533	2.7(27)
CL-36	6	3~36	6~32	6~26	22.5(2300)	48.5(4950)	6000	0.062	7.0	171E	TK-C643	2.3(23)
CL-42	6	3~42	6~36	6~29	24.5(2500)	52.9(5400)	6000	0.060	6.9	173E	TK-C643	2.5(25)
CL-52	6	5~52	8~45	7~36	27.4(2800)	59.0(6020)	6000	0.101	14.3	177E	TK-A853	2.0(20)
CL-6017	6	5~60	8~52	7~42	29.4(3000)	63.7(6500)	5000	0.098	14.1	185E	TK-A1068	1.8(18)
CL-6022	6	5~60	8~52	7~42	29.4(3000)	63.7(6500)	5000	0.126	16.3	185E	TK-A1068	1.8(18)
CL-80	6	20~80	18~69	15~56	34.3(3500)	71.5(7300)	4000	0.108	17.8	193E	TK-A1287	1.6(16)

DIMENSIONS

Model	A	A1	B	C(H6)	D	E	E1	F max.	F min.	G max.	G min.	H	J	K max.	L	L1	M
CL-26	120	85	100	110	82.6	4	23	26	3	7	2.5	15	12	M40x1.5	3~M10x25	16	4
CL-30	120	85	100	110	82.6	4	23	30	3	7	2.5	15	12	M40x1.5	3~M10x25	16	4
CL-36	155	100	120	140	104.8	5	23	36	3	7	1	17.5	20	M55x2	3~M10x25	18	4
CL-42	155	100	120	140	104.8	5	23	42	3	7	1	17.5	20	M55x2	3~M10x25	18	4
CL-52	185	130	145.5	170	133.4	5	27	52	5	9	3	24	30	M60x2	6~M12x30	20	5
CL-6017	185	130	145.5	170	133.4	5	27	60	5	9	3	24	45	M75x2	6~M12x30	20	5
CL-6022	234	130	142	220	171.4	5	32	60	5	13	7	24	45	M85x2	6~M16x30	20	5
CL-80	234	156	163	220	171.4	5	32	80	20	15.5	9.5	22	45	M100x2	6~M16x30	20	5



- PUSH type collet used mainly on turning, CNC, special purpose machines , ect.
- High clamping accuracy, high speed and high rigidity.
- The installation is the same as "Thru-hole power chuck" and they are replaceable with each other.
- Sealed against swarf, chips and coolant.
- The collet used must accord with DIN 6343.
- Patent numbers :
 PAT.NO.M380842(Taiwan)
 PAT.NO.ZL201020113762.X(China)

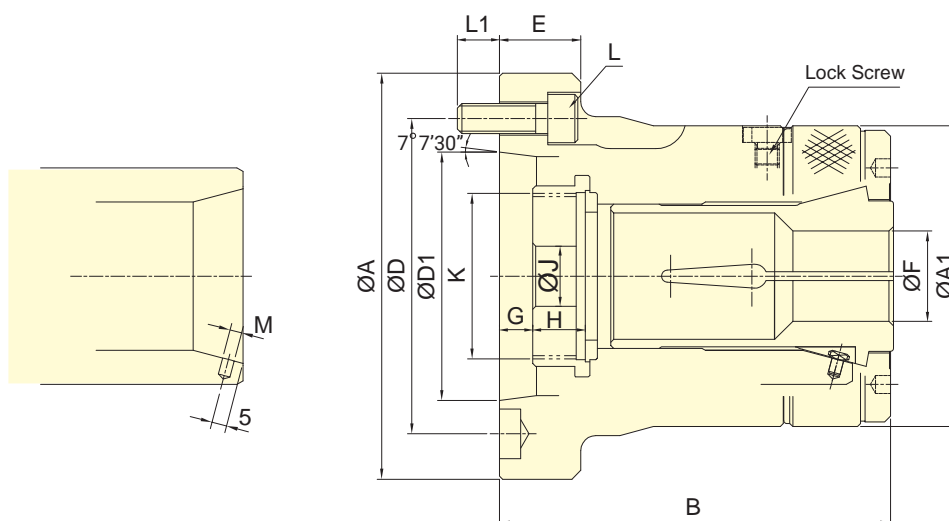

Subject to technical changes

SPECIFICATIONS

Model	Plunger stroke	Max. Chucking Capacity			Max. D.B. pull	Max. clamping force	Max. speed	Mo-ment of inertia	Weight	Matching steel collet	Matching Cyl.	Max. pressure	
		Round	Hex- agom	Square									mm
CL-26	A4	4.5	3~26	4~22	4~18	17.6(1800)	37.9(3870)	8000	0.040	4.2	161E	TK-A533	2.4(24)
CL-30	A4	4.5	3~30	4~26	4~20	19.6(2000)	42.1(4300)	8000	0.038	4.1	163E	TK-A533	2.7(27)
CL-36	A5	6	3~36	6~32	6~26	22.5(2300)	48.5(4950)	6000	0.058	6.3	171E	TK-C643	2.3(23)
CL-42	A5	6	3~42	6~36	6~29	24.5(2500)	52.9(5400)	6000	0.057	6.1	173E	TK-C643	2.5(25)
CL-42	A6	6	3~42	6~36	6~29	24.5(2500)	52.9(5400)	6000	0.061	7.5	173E	TK-C643	2.5(25)
CL-52	A6	6	5~52	8~45	7~36	27.4(2800)	59.0(6020)	6000	0.093	13.8	177E	TK-A853	2.0(20)
CL-60	A6	6	5~60	8~52	7~42	29.4(3000)	63.7(6500)	5000	0.091	13.5	185E	TK-A1068	1.8(18)
CL-60	A8	6	5~60	8~52	7~42	29.4(3000)	63.7(6500)	5000	0.104	14.5	185E	TK-A1068	1.8(18)
CL-80	A8	6	20~80	18~69	15~56	34.3(3500)	71.5(7300)	4000	0.120	19.8	193E	TK-A1287	1.6(16)

DIMENSIONS

Model	A	A1	B	D	D1	E	F max.	F min.	G max.	G min.	H	J	K max.	L	L1	M
CL-26	A4	110	85	108	82.6	63.51	25	26	3	9.5	5	15	12	M40x1.5	3~M10x30	15 4
CL-30	A4	110	85	108	82.6	63.51	25	30	3	9.5	5	15	12	M40x1.5	3~M10x30	15 4
CL-36	A5	135	100	130	104.8	82.56	27	36	3	14	8	17.5	20	M55x2	4~M10x30	14 4
CL-42	A5	135	100	130	104.8	82.56	27	42	3	14	8	17.5	20	M55x2	4~M10x30	14 4
CL-42	A6	165	100	130	133.4	106.38	32	42	3	17	11	17.5	20	M60x2	4~M12x35	16 4
CL-52	A6	170	130	154	133.4	106.38	27	52	5	10.5	4.5	24	45	M60x2	4~M12x35	20 5
CL-60	A6	170	130	154	133.4	106.38	27	60	5	10.5	4.5	24	45	M75x2	4~M12x35	20 5
CL-60	A8	210	130	147.5	171.4	139.72	35	60	5	3.5	-2.5	24	45	M85x2	4~M16x40	22 5
CL-80	A8	210	156	175	171.4	139.72	35	80	20	7.5	1.5	22	45	M100x2	6~M16x40	22 5



- DRAW BACK type collet chuck used mainly on CNC turning machines, special purpose machines, etc.
- Suitable for machining bar material and mandrel.
- High clamping accuracy, high speed and high rigidity.
- The installation is the same as "Thru-hole power chuck" and they are replaceable with each other.
- This is a completely sealed design, which prevents coolant and chips from entering the spindle.
- J is the hole diameter of blank draw nut.
K is the maximum thread specification and it could be customize.

COLLET CHUCKS

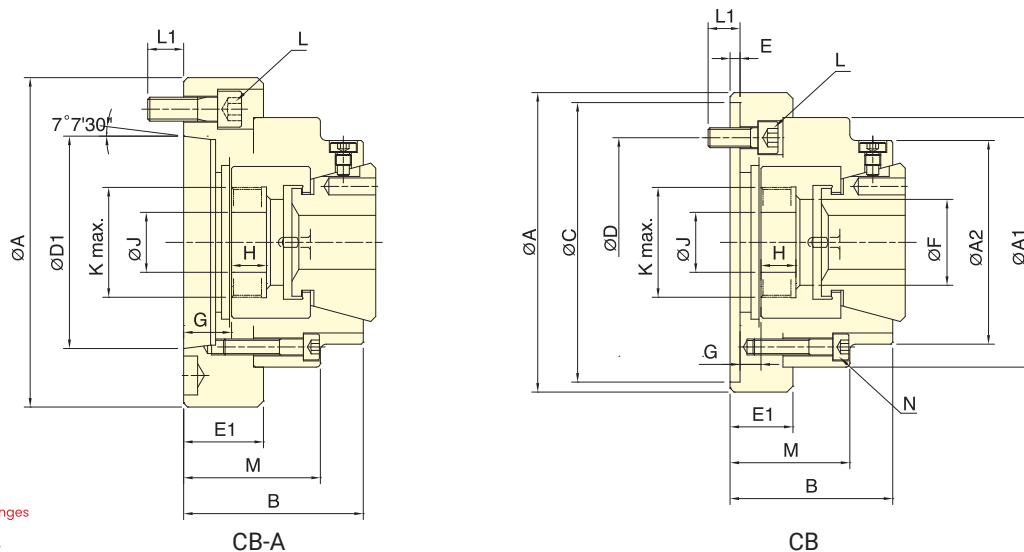

Subject to technical changes

SPECIFICATIONS

Model	Plunger stroke mm	Max. Chucking Capacity			Max. D.B. pull kN (kgf)	Max. clamping force kN (kgf)	Max. speed min ⁻¹ (r.p.m.)	Weight kg	Matching steel collet	Matching Cyl.	Max. pressure MPa (kgf/cm ²)
		Round mm	Hexagom mm	Square mm							
CB-42	4.5	4~42	7~36	7~30	34.3(3500)	78.4(8000)	7000	6.5	RG-42	TK-B846	2.8(28)
CB-42 A5	4.5	4~42	7~36	7~30	34.3(3500)	78.4(8000)	7000	6.2	RG-42	TK-B846	2.8(28)
CB-42 A6	4.5	4~42	7~36	7~30	34.3(3500)	78.4(8000)	7000	7.4	RG-42	TK-B846	2.8(28)
CB-52	4.5	4~52	7~36	7~45	39.2(4000)	92.1(9400)	7000	6	RG-52	TK-A853	3.2(32)
CB-5217	4.5	4~52	7~36	7~45	39.2(4000)	92.1(9400)	7000	9.6	RG-52	TK-A853	3.2(32)
CB-52 A5	4.5	4~52	7~36	7~45	39.2(4000)	92.1(9400)	7000	6.5	RG-52	TK-A853	3.2(32)
CB-52 A6	4.5	4~52	7~36	7~45	39.2(4000)	92.1(9400)	7000	7.8	RG-52	TK-A853	3.2(32)
CB-65	4.5	4~65	8~56	8~46	44.1(4500)	103(10500)	5500	15	RG-65	TK-A1068	3.0(30)
CB-65 A6	4.5	4~65	8~56	8~46	44.1(4500)	103(10500)	5500	13.6	RG-65	TK-A1068	3.0(30)
CB-65 A8	4.5	4~65	8~56	8~46	44.1(4500)	103(10500)	5500	17.6	RG-65	TK-A1068	3.0(30)
CB-80	5.5	5~80	8~68	8~56	50.0(5100)	115(11730)	5500	19	RG-80	TK-A1287	2.3(23)
CB-80 A8	5.5	5~80	8~68	8~56	50.0(5100)	115(11730)	5500	19	RG-80	TK-A1287	2.3(23)

DIMENSIONS

Model	A	A1	A2	B	C(H6)	D	D1	E	E1	F	G max.	G min.	H	J	K max.	L	L1	M	N
CB-42	150	125	102	81.5	140	104.8	-	5	31	43	10.5	6	17.5	30	M55x2	3~M10x25	11	60	4~M8
CB-42 A5	140	125	102	91.5	-	104.8	82.56	-	41.5	43	25.5	21	17.5	30	M55x2	4~M10x25	12	70	4~M8
CB-42 A6	165	125	102	91.5	-	133.4	106.38	-	45	43	29	24.5	17.5	30	M55x2	4~M12x35	18	73.5	4~M8
CB-52	150	125	102	83.5	140	104.8	-	5	31.5	53	11	6.5	17.5	30	M60x2	4~M10x25	16	62.5	4~M8
CB-5217	180	125	102	87	170	133.4	-	5	35	53	14.5	10	17.5	30	M60x2	4~M12x30	18	66	4~M8
CB-52 A5	140	125	102	93.5	-	104.8	82.56	-	41.5	53	26	21.5	17.5	30	M60x2	4~M10x30	16	72.5	4~M8
CB-52 A6	165	125	102	99	-	133.4	106.38	-	47	53	31.5	27	17.5	30	M60x2	6~M12x35	18	78	4~M8
CB-65	185	145	120	100	170	133.4	-	6	50	66	13.5	9	21.5	32	M75x2	6~M12x40	20	73.5	4~M8
CB-65 A6	165	145	120	111	-	133.4	106.38	-	61	66	30.5	26	21.5	32	M75x2	4~M12x40	20	84.5	4~M8
CB-65 A8	207	145	120	107	-	171.4	139.72	-	57	66	26.5	22	21.5	32	M75x2	4~M16x40	24	80.5	4~M8
CB-80	235	175	150	112	220	171.4	-	5	37	82.5	13.5	8	25	45	M85x2	6~M16x30	22	87	6~M10
CB-80 A8	210	175	150	125	-	171.4	139.72	-	50	82.5	26.5	21	25	45	M85x2	6~M16x50	24	100	6~M10



- End stop clamping.
- With backgauge block mechanism, positioning and the length control of the workpiece can be more precise.
- Backgauge block and cover are interchangeable. The chip-proof function can also be achieved.
- J is the hole diameter of blank draw nut.
K is the maximum thread specification and it could be customize.

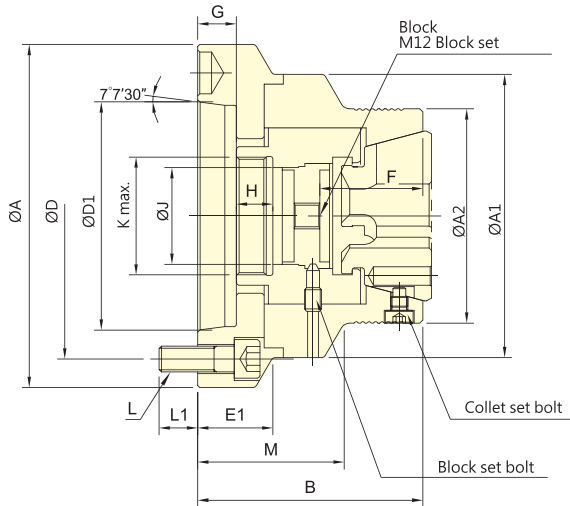

CBE-A

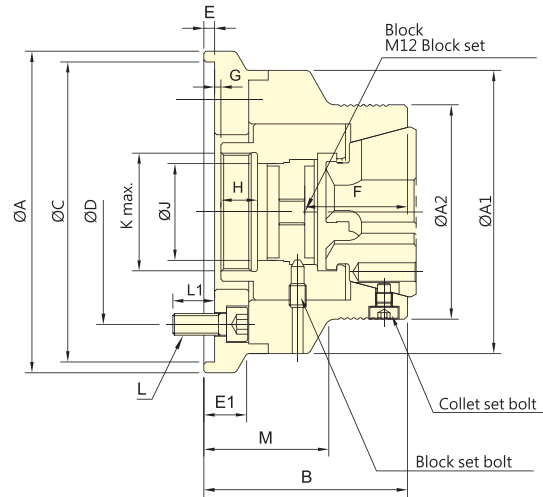

CBE

Subject to technical changes

SPECIFICATIONS

Model	Plunger stroke	Max. Chucking Capacity			Max. D.B. pull	Max. clamping force	Max. speed	Weight	Matching steel collet	Matching Cyl.	Max. pressure
		Round	Hex-agon	Square							
	mm	mm	mm	mm	kN (kgf)	kN (kgf)	min ⁻¹ (r.p.m.)	kg			MPa (kgf/cm ²)
CBE-42	4.5	4~42	7~36	7~30	34.3(3500)	78.4(8000)	7000	6	RG-42	TK-B846	2.8(28)
CBE-4212	4.5	4~42	7~36	7~30	34.3(3500)	78.4(8000)	7000	6	RG-42	TK-B846	2.8(28)
CBE-42 A5	4.5	4~42	7~36	7~30	34.3(3500)	78.4(8000)	7000	6.3	RG-42	TK-B846	2.8(28)
CBE-42 A6	4.5	4~42	7~36	7~30	34.3(3500)	78.4(8000)	7000	7.4	RG-42	TK-B846	2.8(28)
CBE-52	4.5	4~52	7~36	7~30	39.2(4000)	92.1(9400)	7000	6.9	RG-52	TK-A853	3.2(32)
CBE-5212	4.5	4~52	7~36	7~30	39.2(4000)	92.1(9400)	7000	6.7	RG-52	TK-A853	3.2(32)
CBE-5217	4.5	4~52	7~36	7~30	39.2(4000)	92.1(9400)	7000	8.9	RG-52	TK-A853	3.2(32)
CBE-52 A5	4.5	4~52	7~36	7~30	39.2(4000)	92.1(9400)	7000	7.8	RG-52	TK-A853	3.2(32)
CBE-52 A6	4.5	4~52	7~36	7~30	39.2(4000)	92.1(9400)	7000	8.3	RG-52	TK-A853	3.2(32)
CBE-65	4.5	4~65	8~56	8~46	44.1(4500)	103(10500)	6000	8.6	RG-65	TK-A1068	3.0(30)
CBE-6514	4.5	4~65	8~56	8~46	44.1(4500)	103(10500)	6000	9.3	RG-65	TK-A1068	3.0(30)
CBE-65 A5	4.5	4~65	8~56	8~46	44.1(4500)	103(10500)	6000	10.8	RG-65	TK-A1068	3.0(30)
CBE-65 A6	4.5	4~65	8~56	8~46	44.1(4500)	103(10500)	6000	9.5	RG-65	TK-A1068	3.0(30)
CBE-65 A8	4.5	4~65	8~56	8~46	44.1(4500)	103(10500)	6000	9.5	RG-65	TK-A1068	3.0(30)

DIMENSIONS

Model	A	A1	A2	B	C (H6)	D	D1	E	E1	F	G max.	G min.	H	J	K max.	L	L1	M
CBE-42	150	132	100	95	140	104.8	-	5	20	48	5.5	1	17	45	M55x2	4~M10x25	19.5	58
CBE-4212	132	132	100	95	120	100	-	5	-	48	5.5	1	17	45	M55x2	4~M10x25	19.5	58
CBE-42 A5	132	132	100	105	-	104.8	82.56	-	-	48	20.5	16	17	45	M55x2	4~M10x30	16	68
CBE-42 A6	160	132	100	105	-	133.4	106.38	-	35	48	20.5	16	17	45	M55x2	4~M12x35	18	68
CBE-52	150	140	107	99	140	104.8	-	5	-	52	5.5	1	17	56	M60x2	4~M10x20	14.5	60
CBE-5212	140	140	107	99	120	100	-	5	-	52	5.5	1	17	56	M60x2	4~M10x20	14.5	60
CBE-5217	180	140	107	109	170	133.4	-	6	-	52	14.5	10	17	56	M60x2	4~M12x30	18	70
CBE-52 A5	140	140	107	109	-	104.8	82.56	-	-	52	20.5	16	17	56	M60x2	4~M10x30	16	70
CBE-52 A6	160	140	107	109	-	133.4	106.37	-	-	52	20.5	16	17	56	M60x2	4~M12x35	18	70
CBE-65	180	157	122	114	170	133.4	-	6	24	56	15	10.5	17.5	68	M75x2	4~M12x30	18	72
CBE-6514	157	157	122	116	140	104.8	-	6	-	56	17	12.5	17.5	68	M75x2	4~M10x30	18	74
CBE-65 A5	157	157	122	114	-	104.8	82.56	-	-	56	21	16.5	17.5	68	M75x2	4~M10x25	16	72
CBE-65 A6	157	157	122	112	-	133.4	106.38	-	-	56	19	14.5	17.5	68	M75x2	4~M12x35	18.5	70
CBE-65 A8	202	157	122	116	-	171.4	139.72	-	38	56	23	18.5	17.5	68	M75x2	4~M16x35	24	74

COLLET CHUCKS



- Clamping push with the backgauge block mechanism, collet will not be pushed, can precise positioning for workpiece length, make the precision of the length control more precise.
- Match AUTOGRIP's Rubber collet(RG series), clamping direction perpendicular to axis, never occur that situation of collet push workpiece.
- Backgauge block and cover able to interchangeable use, as well as application and chip-proof function.
- J is the hole diameter of blank draw nut.
K is the maximum thread specification and it could be customize.

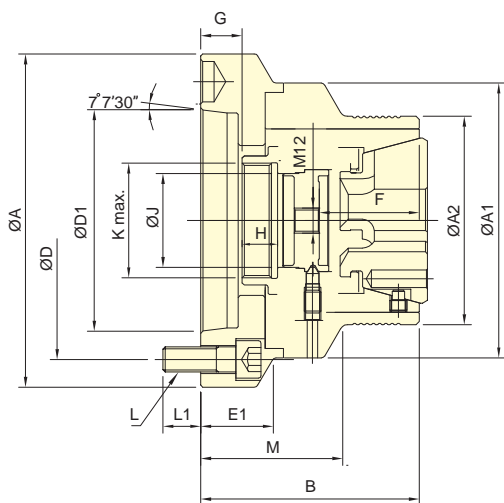

CBD-A

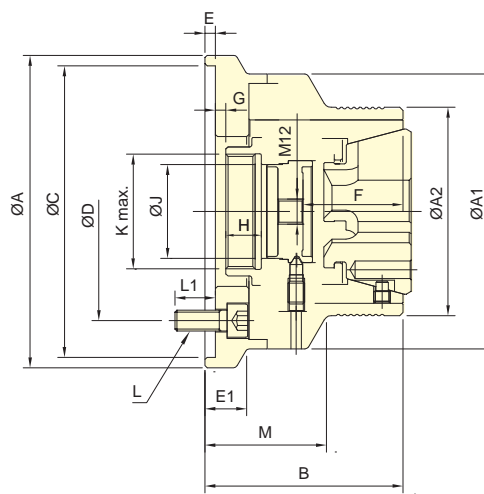

CBD

Subject to technical changes

SPECIFICATIONS

Model	Plunger stroke	Max. Chucking Capacity			Max. D.B. pull	Max. clamping force	Max. speed	Weight	Matching steel collet	Matching Cyl.	Max. pressure	
		Round	Hexagom	Square								mm
CBD-52	4.5	4~52	7~36	7~45	39.2(4000)	92.1(9400)	7000	7.3	RG-52	TK-A853	3.0(30)	
CBD-5212	4.5	4~52	7~36	7~45	39.2(4000)	92.1(9400)	7000	7.1	RG-52	TK-A853	3.0(30)	
CBD-5217	4.5	4~52	7~36	7~45	39.2(4000)	92.1(9400)	7000	10.9	RG-52	TK-A853	3.0(30)	
CBD-52	A5	4.5	4~52	7~36	7~45	39.2(4000)	92.1(9400)	7000	7.8	RG-52	TK-A853	3.0(30)
CBD-52	A6	4.5	4~52	7~36	7~45	39.2(4000)	92.1(9400)	7000	9.1	RG-52	TK-A853	3.0(30)
CBD-65		4.5	4~65	8~56	8~46	44.1(4500)	103(10500)	6000	8.6	RG-65	TK-A1068	2.7(27)
CBD-6514		4.5	4~65	8~56	8~46	44.1(4500)	103(10500)	6000	9.3	RG-65	TK-A1068	2.7(27)
CBD-65	A5	4.5	4~65	8~56	8~46	44.1(4500)	103(10500)	6000	10.8	RG-65	TK-A1068	2.7(27)
CBD-65	A6	4.5	4~65	8~56	8~46	44.1(4500)	103(10500)	6000	9.5	RG-65	TK-A1068	2.7(27)
CBD-65	A8	4.5	4~65	8~56	8~46	44.1(4500)	103(10500)	6000	9.5	RG-65	TK-A1068	2.7(27)

DIMENSIONS

Model	A	A1	A2	B	C (H6)	D	D1	E	E1	F	G max.	G min.	H	J	K max.	L	L1	M
CBD-52	150	140	116	99	140	104.8	-	5	-	52	7	2.5	17	56	M60x2	4~M10x20	14.5	57
CBD-5212	140	140	116	99	120	100	-	5	-	52	7	2.5	17	56	M60x2	4~M10x20	14.5	57
CBD-5217	180	140	116	109	170	133.4	-	6	-	52	16	11.5	17	56	M60x2	4~M12x30	18	67
CBD-52	A5	140	140	116	109	-	104.8	82.56	-	52	22	17.5	17	56	M60x2	4~M10x30	16	67
CBD-52	A6	160	140	116	109	-	133.4	106.38	-	52	22	17.5	17	56	M60x2	4~M12x35	18	67
CBD-65		180	157	132	112	170	133.4	-	6	24	54	15.5	11	68	M75x2	4~M12x30	18	70
CBD-6514		157	157	132	114	140	104.8	-	6	-	54	17.5	13	68	M75x2	4~M10x30	18	72
CBD-65	A5	157	157	132	112	-	104.8	82.56	-	54	21.5	17	17.5	68	M75x2	4~M10x25	16	70
CBD-65	A6	157	157	132	110	-	133.4	106.38	-	54	19.5	15	17.5	68	M75x2	4~M12x35	18.5	68
CBD-65	A8	202	157	132	114	-	171.4	139.72	-	38	54	23.5	19	68	M75x2	4~M16x35	24	72



- Build-in cylinder, ideal for drilling machines, milling machines and machining centers
- Work with AUTOGRIP's rubber collet(RG series), quick change and saving runtime.
- Two modes for the media supply: side-supply mode or baseplate-supply mode.

COLLET CHUCKS

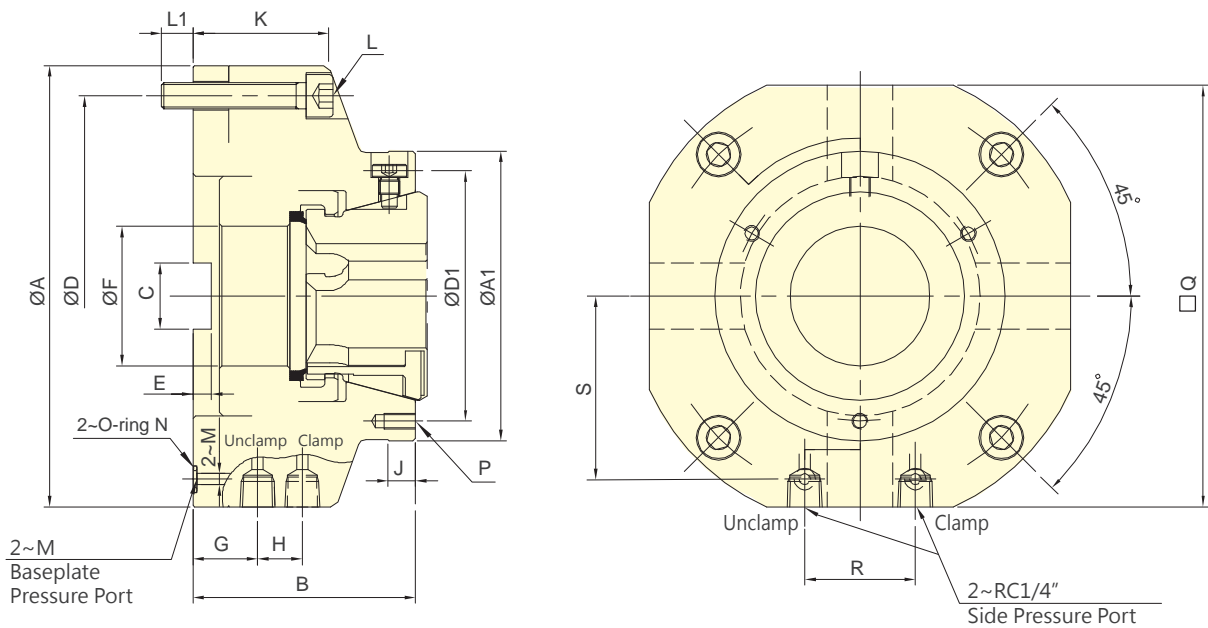

Subject to technical changes

SPECIFICATIONS

Model	Jaw stroke(Dia.) mm	Max. Chucking Capacity			Max. clamping force kN (kgf)	Weight kg	Matching steel collet	Max. pressure MPa (kgf/cm ²)
		Round mm	Hexagom mm	Square mm				
SCB-52	± 0.5	4~52	7~45	7~36	80(8150)	8.6	RG-52	4.0(40)
SCB-65	± 0.5	4~65	8~56	8~46	105(10700)	10.2	RG-65	4.2(42)

DIMENSIONS

Model	A (g6)	A1	B	C	D	D1	E	F	G	H
SCB-52	175	110	84.5	25	152	95	7	53	24.5	17
SCB-65	192	130	94	30	169	114	9	66	26.5	20

Model	J	K	L	L1	M	N	P	Q	R	S
SCB-52	10	51.5	4~M10	12	4.2	P7	3~M6x12	160	42	69.5
SCB-65	10	61.5	4~M10	12.5	4.2	P7	3~M6x12	175	50	77



- Rubber grip collet for push type or draw type collet chucks.
- Full gripping area: high rigidity, more gripping force.
Gripping smoothly: prevent to damage the workpiece.
- More accurate than standard spring collets.
Accuracy: With customized rubber grip collet.
- Grip Range: $\pm 0.5\text{mm}$.
- Quick change and easy.
- Dust-proof and swarf-proof design.

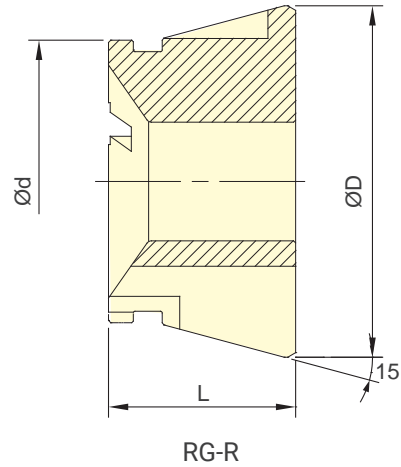
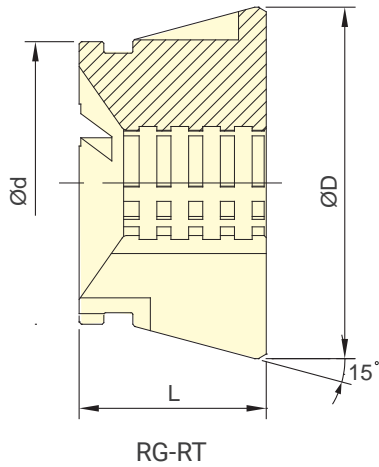

Subject to technical changes

SPECIFICATIONS

Model	Max. Chucking Capacity		d	D	L	Matching Collect Chuck
	Round	mm				
RG-42R	4~42		54	79.3	42	CB-42, CBE-42
RG-42RT	11~42		54	79.3	42	CB-42, CBE-42
RG-52R	4~52		66	79.3	46	CB-52, CBD-52, CBE-52, SCB-52
RG-52RT	11~52		66	79.3	46	CB-52, CBD-52, CBE-52, SCB-52
RG-65R	4~65		80	99.5	53	CB-65, CBD-65, CBE-65, SCB-65
RG-65RT	11~65		80	99.5	53	CB-65, CBD-65, CBE-65, SCB-65

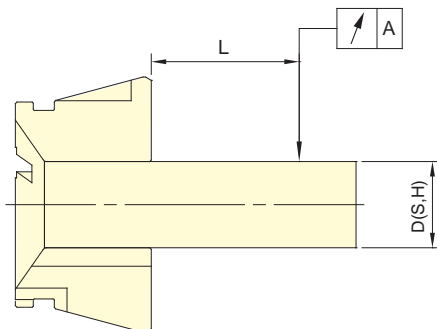

Test Bar D(S,H)	L mm	A DIN	
		Class1	Class2
3.0~6.0	16	0.015	0.020
6.0~10.0	25	0.015	0.020
10.0~18.0	40	0.020	0.030
18.0~24.0	50	0.020	0.030
24.0~30.0	60	0.020	0.030
30.0~50.0	80	0.030	0.040
50.0~60.0	100	0.030	0.040

Note1 : Collets chuck are conformed to DIN 6343 Class2.
 Note2 : AUTOGRIP's rubber grip collets are conformed to DIN 6343 Class1.

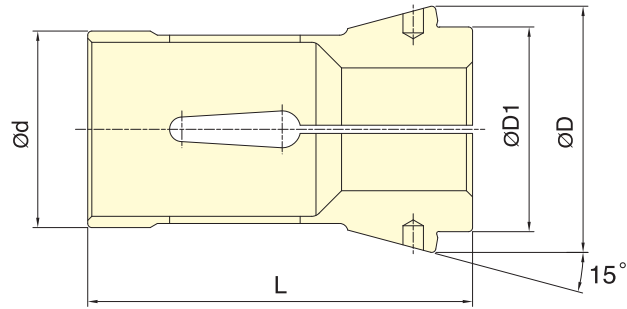

DIN 6343 Collet standard

Subject to technical changes

DIMENSIONS

Collet	Max. Chucking Capacity (mm)			d	D	D1	L	Matching Collet Chuck
	Round	Hexagom	Square					
161E	3~26	4~22	4~18	32	45	34	75	CL-26, CL-26A4
163E	3~30	4~26	4~20	35	48	38	80	CL-30, CL-30A4
171E	3~36	6~32	6~26	42	55	42	94	CL-36, CL-36A5
173E	3~42	6~36	6~29	48	60	50	94	CL-42, CL-42A5, CL-42A6
177E	5~52	8~45	7~36	58	70	60	94	CL-52, CL-52A6
185E	5~60	8~52	7~42	66	84	73	110	CL-6017, CL-6022, CL-60A6, CL-60A8
193E	20~80	18~69	15~56	90	107	92	130	CL-80, CL-80A8

Test Bar D(S,H)	L mm	A DIN	
		Class 1	Class 2
0.5~1.0	3	0.015	0.015
1.0~1.6	6	0.015	0.020
1.6~3.0	10	0.015	0.020
3.0~6.0	16	0.015	0.020
6.0~10.0	25	0.015	0.020
10.0~18.0	40	0.020	0.030
18.0~24.0	50	0.020	0.030
24.0~30.0	60	0.020	0.030
30.0~50.0	80	0.030	0.040
50.0~60.0	100	0.030	0.040

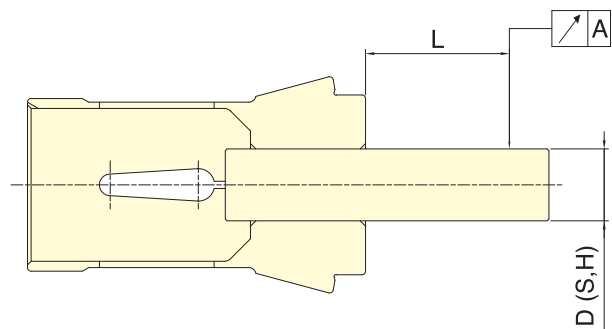

Note: Collets chuck are conformed to DIN 6343 Class2.

COLLET CHUCKS



- Stationary Chuck with two or three jaws for drilling, milling and other machines.
- Specification and size of matching chuck for model VH2-2200 is the same as model 2H-2.
- Specification and size of matching chuck for model VH2-3200 is the same as model 3H-2.

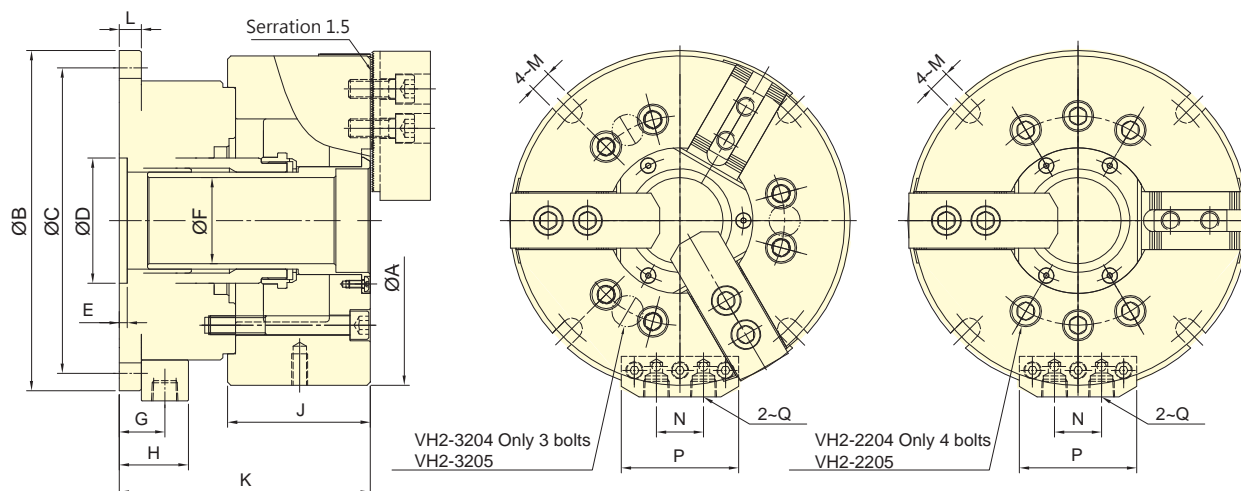

Subject to technical changes

SPECIFICATIONS

Model	Eff. Piston area		Jaw stroke(Dia.) mm	Max. pressure MPa(kgf/cm ²)	Weight kg
	Extend cm ²	Retract cm ²			
VH2-2204	52.4	46.7	5.5	2.0 (20)	9.5
VH2-3204	52.4	46.7	5.5	3.0 (30)	9.5
VH2-2205	63.7	57.9	5.5	2.0 (20)	13.1
VH2-3205	63.7	57.9	5.5	3.0 (30)	12.6
VH2-2206	97.1	88.5	6.0	1.8 (17.9)	21.5
VH2-3206	97.1	88.5	6.0	2.7 (26.8)	21.5
VH2-2208	128.9	113.6	7.6	2.1 (20.7)	32.9
VH2-3208	128.9	113.6	7.6	2.9 (28.6)	33.4
VH2-2210	189.2	174.3	8.9	1.9 (19.2)	55
VH2-3210	189.2	174.3	8.9	2.9 (28.7)	59

DIMENSIONS

Model	A	B	C	D(H7)	E	F	G	H	J	K	L	M	N	P	Q
VH2-2204	113	155	137	50	5	27	23	34	59	122.5	12	9	26	62	RC1/4
VH2-3204	113	155	137	50	5	27	23	34	59	122.5	12	9	26	62	RC1/4
VH2-2205	138	168	150	60	5	32	23	34	60	125	12	9	26	62	RC1/4
VH2-3205	138	168	150	60	5	32	23	34	60	125	12	9	26	62	RC1/4
VH2-2206	170	194	176	80	5	45	25	36	81	143	14	11	26	62	RC1/4
VH2-3206	170	194	176	80	5	45	25	36	81	143	14	11	26	62	RC1/4
VH2-2208	210	217	195	80	5	55	29	44	91	160	14	13.5	30	75	RC3/8
VH2-3208	210	217	195	80	5	55	29	44	91	160	14	13.5	30	75	RC3/8
VH2-2210	260	266	246	100	6	76	32	47	102	192	17	13.5	30	75	RC3/8
VH2-3210	260	266	246	100	6	76	32	47	102	192	17	13.5	30	75	RC3/8



- Stationary Chuck with two or three jaws for drilling, milling and other machines.
- Specification and size of matching chuck for model VP-200 is the same as model 2P.
- Specification and size of matching chuck for model VP-300 is the same as model 3P.

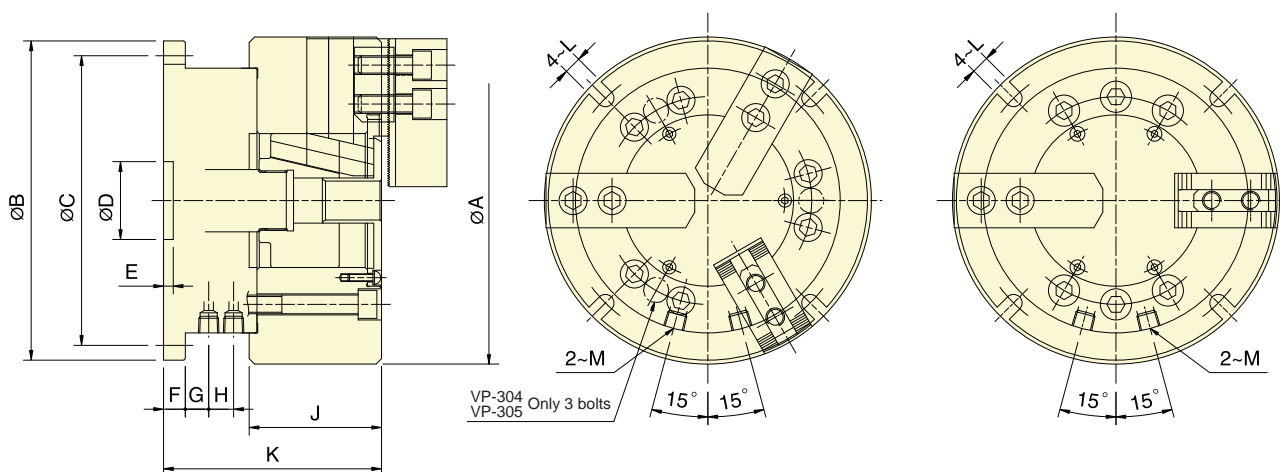

Subject to technical changes

SPECIFICATIONS

Model	Eff. Piston area		Jaw stroke(Dia.) mm	Max. pressure MPa(kgf/cm ²)	Weight kg
	Extend cm ²	Retract cm ²			
VP-204	28.0	24.9	6.4	2.1(21)	7.1
VP-304	28.0	24.9	6.4	3.2(32)	7.4
VP-205	28.0	24.9	6.4	2.2(22)	10.2
VP-305	28.0	24.9	6.4	3.3(33)	10.6
VP-206	63.1	53.5	8.5	2.3(23)	18.3
VP-306	63.1	53.5	8.5	3.4(34)	19.8
VP-208	103.4	90.8	8.8	1.9(19)	31.6
VP-308	103.4	90.8	8.8	2.8(28)	33.6
VP-210	153.1	133.5	8.8	1.5(15)	52.8
VP-310	153.1	133.5	8.8	2.2(22)	54.5

DIMENSIONS

Model	A	B	C	D(H8)	E	F	G	H	J	K	L	M
VP-204	110	146	130	30	4.5	12	18	2	52	92	9	RC1/4
VP-304	110	146	130	30	4.5	12	18	2	52	92	9	RC1/4
VP-205	135	146	130	30	4.5	12	18	2	55	95	9	RC1/4
VP-305	135	146	130	30	4.5	12	18	2	55	95	9	RC1/4
VP-206	165	178	160	40	5	12	14.5	12.5	74	125	11	RC1/4
VP-306	165	178	160	40	5	12	14.5	12.5	74	125	11	RC1/4
VP-208	210	205	186	40	5	14	15	16	85	140	11	RC1/4
VP-308	210	205	186	40	5	14	15	16	85	140	11	RC1/4
VP-210	254	248	225	50	6	17	20	18	89	176	13	RC3/8
VP-310	254	248	225	50	6	17	20	18	89	176	13	RC3/8

STATIONARY CHUCKS



- Stationary Non-Thru-Hole Chuck and Stationary Thru-Hole Chuck. Two types of jaws (two-jaw, three-jaw).
- Build-in hydraulic cylinder; it can also work with lock valve and be driven by air pressure.
- With small thru-hole and suits for long bar workpiece processing.
- Easy to install. Installing the tubes and then operating.
- Thin and compact design. Use standard soft jaws or standard hard jaws.
- Can work together with multi-plate.

STATIONARY CHUCKS

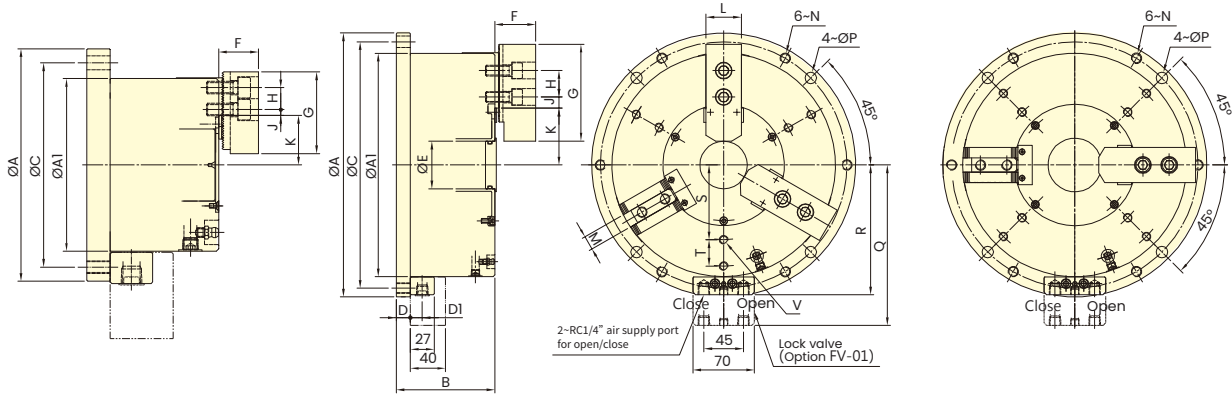

SP-304

SP-306-SP-312

SP-206,SP-208,SP-210

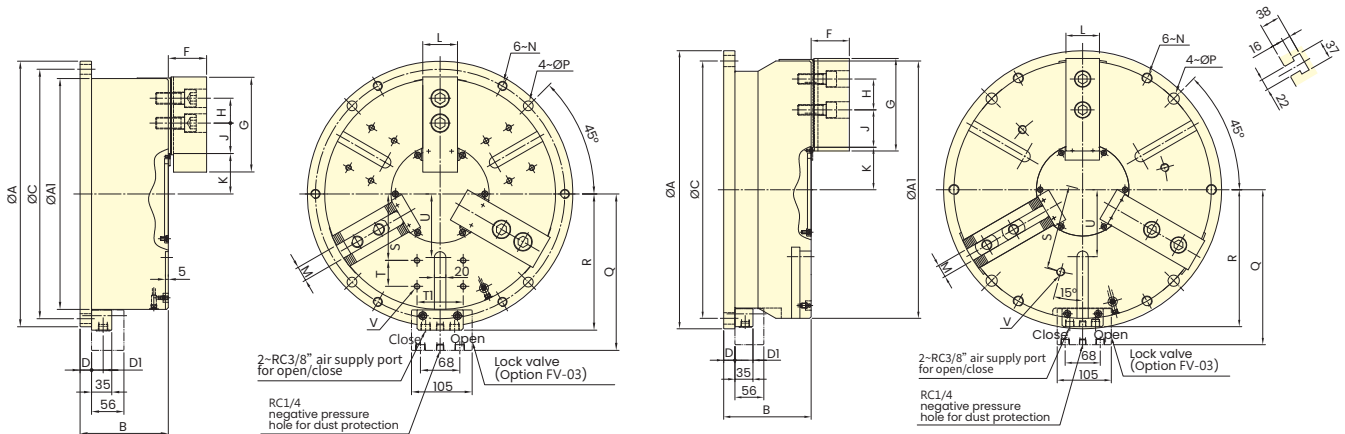

SP-316

SP-320/SP-324

Subject to technical changes

SPECIFICATIONS

Model	Jaw stroke (Dia.) mm	Chucking Dia.		Max. clamping force		Max. pressure		Min. pressure kgf/cm ²	Air consumption lit (at 6.0 kgf/cm ²)	Weight kg
		Max. mm	Min. mm	Pneumatic kN(kgf)	Hydraulic kN(kgf)	Pneumatic MPa(kgf/cm ²)	Hydraulic MPa(kgf/cm ²)			
SP-304	5.1	110	10	7.5(765)	22.0(2243)	0.6(6)	1.3(13)	2	0.5	7
SP-206	5.5	168	30	14.0(1427)	24.0(2450)	0.7(7)	1.2(12)	2	1.4	16
SP-306	5.5	168	30	21.0(2142)	52.0(5303)	0.6(6)	1.3(13)	2	1.4	16.5
SP-208	6.8	210	42	28.9(2946)	49.6(5056)	0.7(7)	1.2(12)	2	2.5	27.7
SP-308	6.8	210	42	33.0(3365)	74.0(7546)	0.6(6)	1.3(13)	2	2.5	28.7
SP-210	7	254	52	41.8(4260)	71.7(7308)	0.7(7)	1.2(12)	2	4.2	41.8
SP-310	7	254	52	48.0(4895)	107.0(10911)	0.6(6)	1.3(13)	2	4.2	42

Model	Jaw stroke (Dia.)	Chucking Dia.		Max. clamping force		Max. pressure		Min. pressure	Air consumption	Weight
		Max.	Min.	Pneumatic	Hydraulic	Pneumatic	Hydraulic			
	mm	mm	mm	kN(kgf)	kN(kgf)	MPa(kgf/cm ²)	MPa(kgf/cm ²)	kgf/cm ²	lit (at 6.0 kgf/cm ²)	kg
SP-312	9.3	304	60	61.3(6246)	132.8(13532)	0.6(6)	1.3(13)	2	6.4	52.8
SP-316	14.5	400	30	96 (9789)	-	0.7 (7)	-	2	10.6	147.8
SP-320	16	500	45	104 (10605)	-	0.7 (7)	-	2	15	232.7
SP-324	16	600	140	153 (15602)	-	0.7 (7)	-	2	22	338.7

DIMENSIONS

Model	A(h7)	A1	B	C	D	D1	E	F	G	H	J max.	J min.
SP-304	148	110	84	130	15	13.5	-	25	52	14	3.75	0.75
SP-206	206	168	94	188	15	13.5	25	40	73	20	10.75	4.75
SP-306	206	168	94	188	15	13.5	25	40	73	20	10.75	4.75
SP-208	248	210	108	230	15	13.5	32	41	95	25	12.25	8.75
SP-308	248	210	108	230	15	13.5	32	41	95	25	12.25	8.75
SP-210	300	254	112	280	16	13.5	54	46	110	30	23.25	12.75
SP-310	300	254	112	280	16	13.5	54	46	110	30	23.25	12.75
SP-312	350	304	130	330	18	13.5	65	54	130	30	30.75	12.75
SP-316	460	400	153	432	20	20	-	66	165	43	67.75	18.25
SP-320	540	500	170	500	22	20	-	74	180	60	87.5	24.5
SP-324	640	600	175	600	24	20	-	74	180	60	87.5	24.5

Model	K max.	K min.	L	M	N	P	Q	R	S	T	T1	U	V
SP-304	31.5	28.95	23	10	M8x1.25	9	110.5	75.5	-	-	-	-	-
SP-206	47	44.25	31	12	M10x1.5	11	139.5	104.5	55	18	-	-	6~M8x1.25
SP-306	47	44.25	31	12	M10x1.5	11	139.5	104.5	55	18	-	-	6~M8x1.25
SP-208	57	53.6	35	14	M10x1.5	11	160.5	125.5	68	25	-	-	6~M8x1.25
SP-308	57	53.6	35	14	M10x1.5	11	160.5	125.5	68	25	-	-	6~M8x1.25
SP-210	64.5	61	40	16	M12x1.75	13	182.5	147.5	85	30	-	-	6~M10x1.5
SP-310	64.5	61	40	16	M12x1.75	13	182.5	147.5	85	30	-	-	6~M10x1.5
SP-312	77.5	72.85	50	21	M12x1.75	13	207.5	172.5	100	35	-	-	6~M10x1.5
SP-316	70	62.75	60	25.5	M16x2.0	17.5	271	236	115	45	80	110	12~M10x1.5
SP-320	82.5	74.5	65	25	M20x2.5	22	301	266	165	-	-	130	3~M16x2.0
SP-324	129.5	121.5	65	25	M20x2.5	22	351	316	200	-	-	180	3~M16x2.0

LONG JAW STROKE STATIONARY CHUCK



- WEDGE-HOOK type power chuck, and long jaw stroke.
- Build-in hydraulic cylinder; it can also work with lock valve and be driven by air pressure.
- Easy to install. Installing the tubes and then operating.
- Thin and compact design. Use standard soft jaws or standard hard jaws.
- Air-tight pressure detect function is optional.

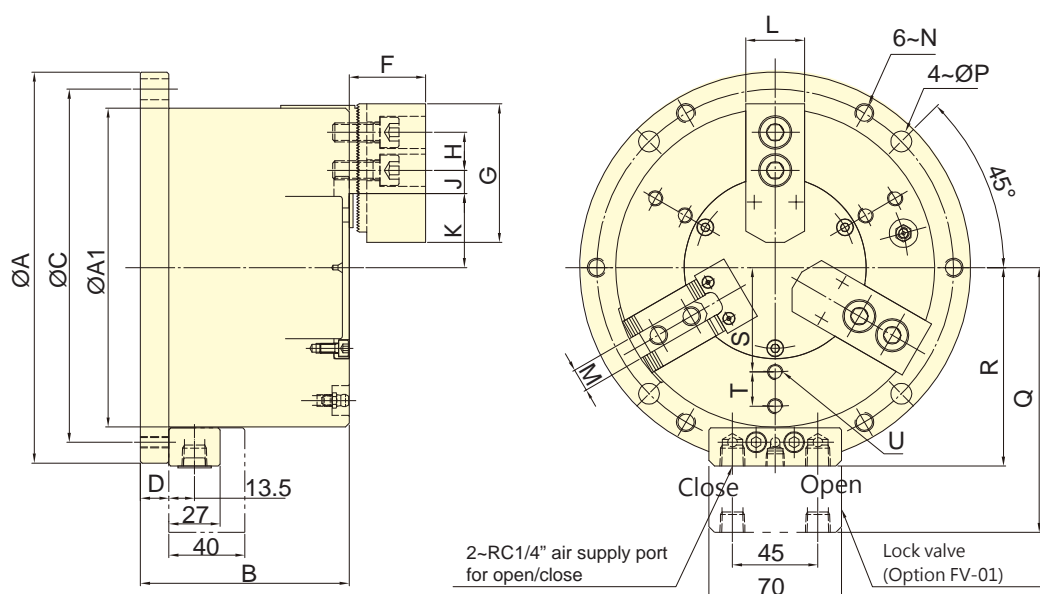

Subject to technical changes

SPECIFICATIONS

Model	Jaw stroke (Dia.) mm	Chucking Dia.		Max. clamping force		Max. pressure		Min. pressure kgf/cm ²	Air consumption lit (at 6.0 kgf/cm ²)	Weight kg
		Max. mm	Min. mm	Pneumatic kN(kgf)	Hydraulic kN(kgf)	Pneumatic MPa(kgf/cm ²)	Hydraulic MPa(kgf/cm ²)			
SM-306	13.1	168	11	15.9(1621)	27.2(2780)	0.7(7)	1.2(12)	2	1.5	18.7
SM-308	16	210	13	26.2(2670)	45.0(4590)	0.7(7)	1.2(12)	2	2.7	32.5
SM-310	19.6	254	18	37.0(3772)	63.0(6422)	0.7(7)	1.2(12)	2	4.6	53.6

DIMENSIONS

Model	A(h7)	A1	B	C	D	F	G	H	J max.	J min.
SM-306	206	168	110	188	15	40	73	20	18.25	7.75
SM-308	248	210	127	230	15	41	95	25	25.25	11.75
SM-310	300	254	145	280	16	46	110	30	36.75	14.25

Model	K max.	K min.	L	M	N	P	Q	R	S	T
SM-306	39	32.45	31	12	M10x1.5	11	139.5	104.5	55	18
SM-308	45	37	35	14	M10x1.5	11	160.5	125.5	68	25
SM-310	50	40.2	40	16	M12x1.75	13	182.5	147.5	85	30

STATIONARY PULL DOWN CHUCK



- Build-in hydraulic cylinder; it can also work with lock valve and be driven by air pressure.
- Radial clamp and axial pull down at the same time, keep the workpiece attaching close to the base surface of the chuck.
- Almost no workpiece uplifting displacement.
- The body with heat treatment and the organization of cylinder pull-down and fine boring, which guarantee to the high clamping precision and durability, it's suitable for heavy duty machining.
- Can work together with multi-plate.
- Airtight pressure detect function is optional.

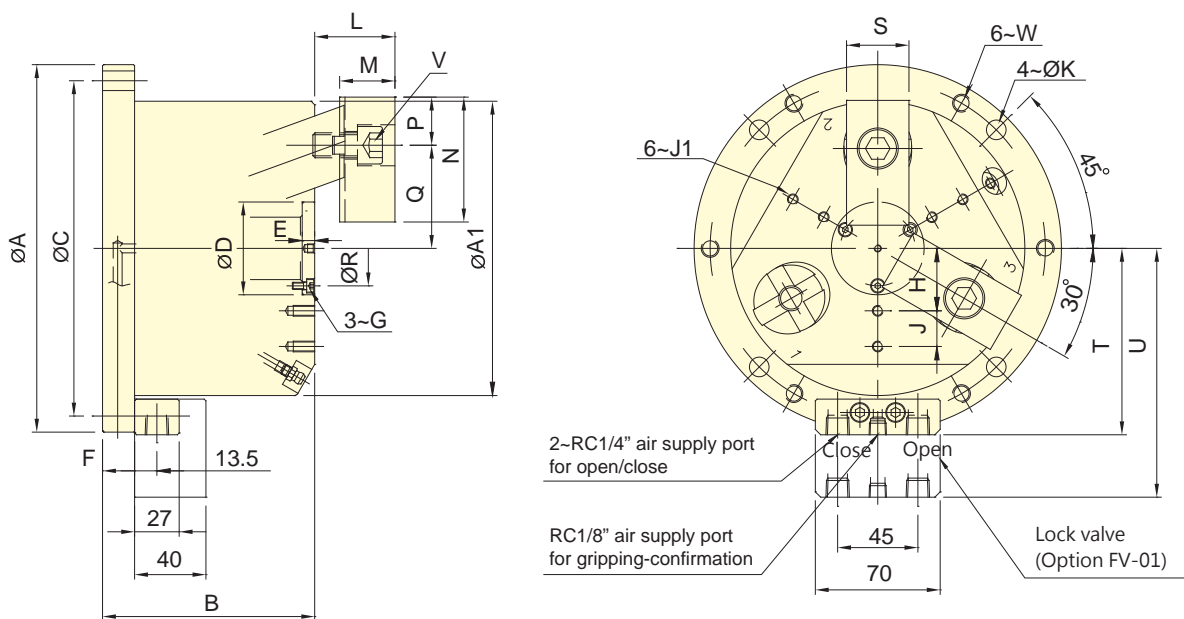

Subject to technical changes

SPECIFICATIONS

Model	Jaw stroke (Dia.) mm	Chucking Dia.		Max. clamping force		Max. pressure		Min. pressure kgf/cm ²	Air consumption lit (at 6.0 kgf/cm ²)	Weight kg
		Max. mm	Min. mm	Pneumatic kN(kgf)	Hydraulic kN(kgf)	Pneumatic MPa(kgf/cm ²)	Hydraulic MPa(kgf/cm ²)			
SD-304	5	110	18	5.0 (510)	10.9 (1112)	0.6 (6)	1.3 (13)	2	0.26	8.1
SD-306	7.2	165	35	11.5 (1173)	25.0 (2550)	0.6 (6)	1.3 (13)	2	0.58	20.6
SD-308	7.2	210	28	21.7 (2213)	47.0 (4793)	0.6 (6)	1.3 (13)	2	1.02	34.1
SD-310	10.8	254	40	36.0(3680)	60.0(6118)	0.6 (6)	1.0 (10)	2	2.05	55

DIMENSIONS

Model	A(h7)	A1	B	C	D(H7/h7)	E	F	G	H	J	J1	K	L max.	L min.
SD-304	148	110	93.5	130	35	2	15	M3	22.5	10	M5x0.8	9	30	23
SD-306	206	165	116	188	52	7	18	M4	35	20	M6x1	11	45	35
SD-308	248	210	122	230	65	10	18	M5	45	25	M8x1.2	11	56	46
SD-310	300	254	151	280	75	12	20	M6	55	30	M8x1.2	13	65	50

Model	M	N	P	Q max.	Q min.	R	S	T	U	V	W
SD-304	19.5	52	19	37	34.5	27	25	75.5	110.5	3~M10	M8x1.25
SD-306	31	70	27	57.8	54.2	42	35	104.5	139.5	3~M14	M10x1.5
SD-308	41	84	31	70.8	67.2	53	40	125.5	160.5	6~M12	M10x1.5
SD-310	46	100	38	85	79.6	62	50	147.5	182.5	6~M14	M12x1.75



- Build-in hydraulic cylinder; it can also work with lock valve and be driven by air pressure.
- Radial clamp and axial pull down at the same time, keep the workpiece attaching close to the base surface of the chuck.
- Almost no workpiece uplifting displacement.
- Suitable for drilling, milling and other machines.
- The body with heat treatment and the organization of cylinder pull-down and fine boring, which guarantee to the high clamping precision and durability, it's suitable for heavy duty machining.
- Can work together with multi-plate.
- Airtight pressure detect function is optional.

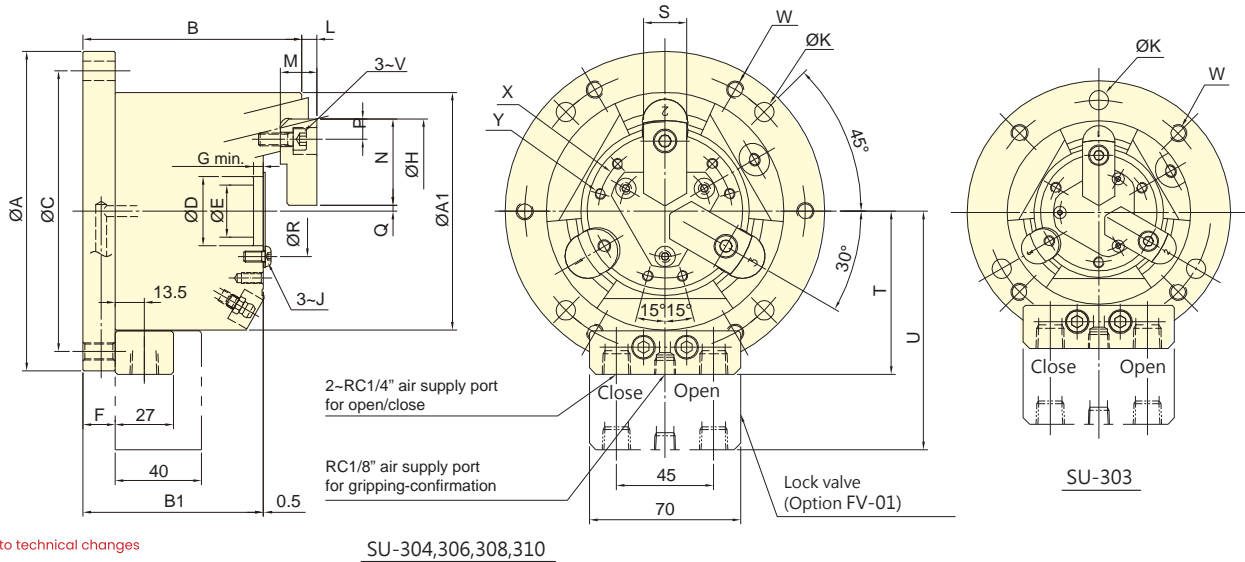

Subject to technical changes

SU-304,306,308,310

SPECIFICATIONS

Model	Jaw stroke (Dia.) mm	Chucking Dia.		Max. clamping force		Max. pressure		Min. pressure kgf/cm ²	Air consumption lit (at 6.0 kgf/cm ²)	Weight kg
		Max. mm	Min. mm	Pneumatic kN(kgf)	Hydraulic kN(kgf)	Pneumatic MPa(kgf/cm ²)	Hydraulic MPa(kgf/cm ²)			
SU-303	2	42	4	5.2(530)	12.8(1305)	0.6(6)	1.3(13)	2	0.16	5.7
SU-304	3	60	5	6.7 (683)	16.0 (1632)	0.6 (6)	1.3 (13)	2	0.26	7.4
SU-306	5	105	31	18.5 (1886)	40.0 (4079)	0.6 (6)	1.3 (13)	2	0.58	18
SU-308	5	132	32	37.0 (3773)	80.0 (8158)	0.6 (6)	1.3 (13)	2	1.02	31.5
SU-310	5	163	44	46.2(4710)	100.0(10100)	0.6(6)	1.3(13)	2	2.11	53

DIMENSIONS

Model	A(h7)	A1	B	B1	C	D(H6)	E	F	G	H(H6)	J	K	L max.	L min.
SU-303	122	85	80.5	68	104	28	22	12	3.5	66	M3	3~9	5	1
SU-304	148	110	101.5	83.5	130	32	24	15	4.5	84	M5	4~9	7	1
SU-306	206	168	136.5	104	188	35	25	18	6	129	M5	4~11	15	5
SU-308	248	210	152	115	230	55	45	18	7	156	M6	4~11	17	7
SU-310	300	254	181	131	280	65	53	20	7	187	M8	4~13	9	-1

Model	M	N	P	Q max.	Q min.	R	S	T	U	V	W	X (p.c.d)	Y
SU-303	12	30	7	3.5	2.5	36	15	63	98	M5	4~M8x1.25	46	3~M5x10
SU-304	17	40	9.5	2.75	1.25	42	20	75.5	110.5	M6	6~M8x1.25	62	6~M5x10
SU-306	30	50	17	15.75	13.25	49	30	104.5	139.5	M10	6~M10x1.5	72	6~M6x12
SU-308	34	63	20.5	16.25	13.75	71	35	125.5	160.5	M12	6~M10x1.5	95	6~M6x12
SU-310	39	74	23	20.75	18.25	85	40	147.5	182.5	M14	6~M12x1.75	115	6~M6x12

STATIONARY EXPANSIBLE PULL BACK CHUCK



- Build-in hydraulic cylinder; it can also work with lock valve and be driven by air pressure.
- For internal gripping.
- With high precision and stability.
- Suitable for the precision large length size process.
- Suitable for end process.
- Can work together with multi-plate.
- Airtight pressure detect function is optional.

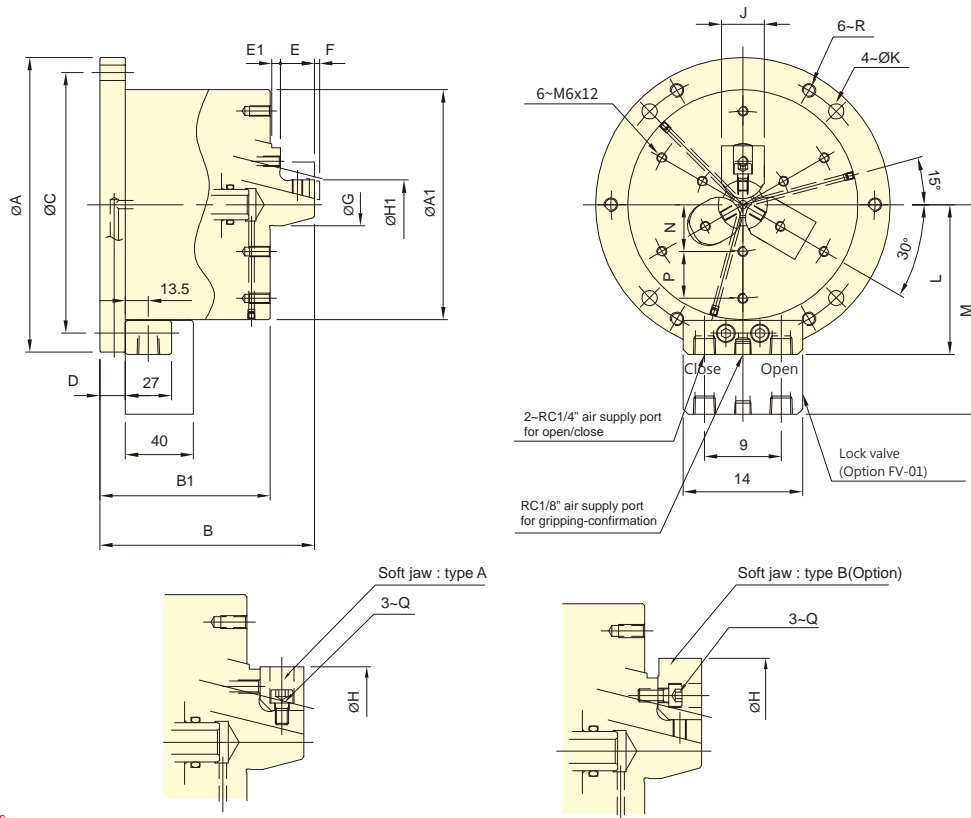

Subject to technical changes

SPECIFICATIONS

Model	Jaw stroke (Dia.) mm	Chucking Dia.		Max. clamping force		Max. pressure		Min. pressure kgf/cm ²	Air consumption lit (at 6.0 kgf/cm ²)	Weight kg
		Max. mm	Min. mm	Pneumatic kN(kgf)	Hydraulic kN(kgf)	Pneumatic MPa(kgf/cm ²)	Hydraulic MPa(kgf/cm ²)			
SE-305	3	83	29	14.3 (1459)	41.0 (4181)	0.7 (7)	1.3 (13)	2	0.46	14.6
SE-306	5	110	44	20.0 (2040)	57.0 (5812)	0.7 (7)	1.3 (13)	2	0.58	20
SE-308	5	150	50	32.0 (3263)	78.0 (7954)	0.7 (7)	1.3 (13)	2	1.02	33

DIMENSIONS

Model	A(h7)	A1	B	B1	C	D	E	E1	F max.	F min.	G	type A		type B	
												H max.	H min.	H max.	H min.
SE-305	173	135	126	100	155	15	20	5	3	-3	25	68	50	83	67
SE-306	206	168	140	108	188	18	23	7	5	-5	40	90	70	110	89
SE-308	248	210	164	119	230	18	30	9	5	-5	49	110	90	150	108

Model	H1		J	K	L	M	N	P	Q	R
	max.	min.								
SE-305	50	29	25	9	88	123	27.5	27.5	3~M6	M8x1.25
SE-306	70	44	31	11	104.5	139.5	38	29	3~M6	M10x1.5
SE-308	90	50	35	11	125.5	160.5	50	35	3~M8	M10x1.5



- Use for milling machine or machining center to achieve simultaneous processing of multiple workpieces.
- Stationary cylinder lock valve (optional) can be mounted.
- Plate for 2,3,6 stationary chucks is optional.

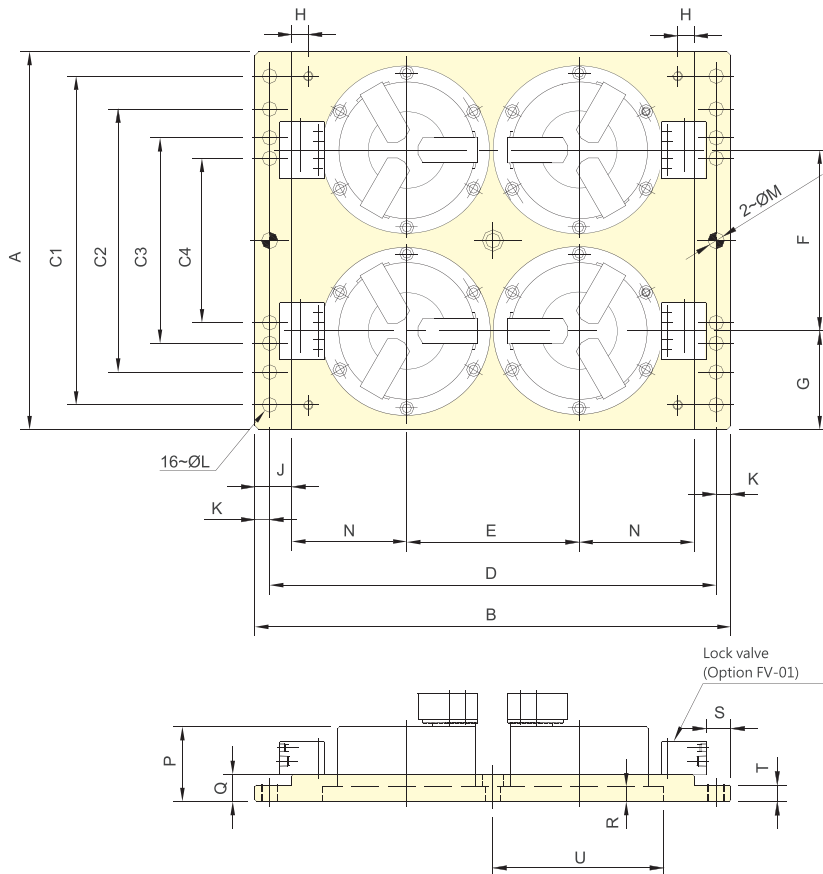

Subject to technical changes

DIMENSIONS

Model	A	B	C1	C2	C3	C4	D	E	F	G
MP4-06206	460	580	400	320	250	200	544	210	220	120

Model	H	J	K	L	M	N	P	Q	R	S	T	U
MP4-06206	20	45	18	17	20	140	*B	33	18	20	20	206

The dimension *B: Please refer to the dimension B of the chuck model assembled.



Subject to technical changes

Max. pressure MPa(kgf/cm ²)	Operating angle	Port size
1.0 (10)	90°	Rc1/4

- Thin and lightweight design and increase the z-axis machining range.
- With the center hole cover and dustproof design for the accuracy and service life of the chuck.
- For 5-axis indexing plates and milling machines.
- 3MF series are not designed for the vertical or horizontal lathes, unless there is a rigid plate and providing adequate support rigidity and strength.

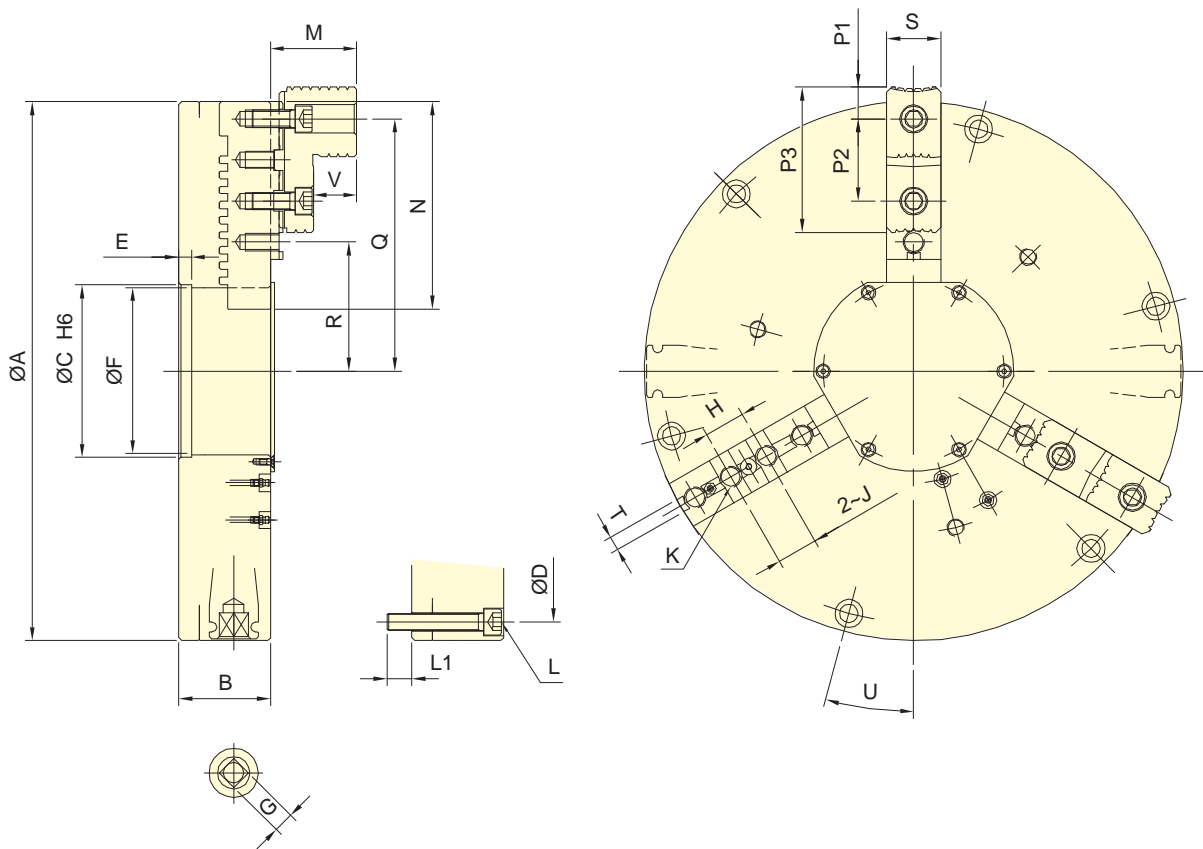

Subject to technical changes

SPECIFICATIONS

Model	Jaw stroke (Dia.)	Chucking Dia. Max.	Chucking Dia. Min.	Max. allowable torque	Max. clamping force	Max. speed	Weight
	mm	mm	mm	N. m (kgf. m)	kN (kgf)	min ⁻¹ (r.p.m.)	kg
3MF-20	80	500	142	170 (17.3)	71.2 (7300)	1150	121

DIMENSIONS

Model	A	B	C (H6)	D	E	F	G	H	J (H7)	K	L	L1	M
3MF-20	500	85	160	465	12	155	□19	38.1	19.03	4~M16	6~M16	23	80
Model	N	P1	P2	P3	Q max.	Q min.	R max.	R min.	S	T (h8)	U	V	Y
3MF-20	192.5	29.5	76.2	135	254	214	139.7	99.7	50	12.7	15°	40	30



- Feed mechanism is Wedge Plunger, with steady feed speed. Simple adjustment for feed speed and stroke.
- Matching surfaces of all parts hardened, grinding and lubricated directly. With rigidity and durability.
- Stopper accuracy: $\pm 0.03\text{mm}$.
- Suitable for using with RS type cylinder.
- For precision processes, Wedge Plunger type facing heads are suitable for using with electro servo and ball screw mechanism.

WEDGE PLUNGER
FA-408

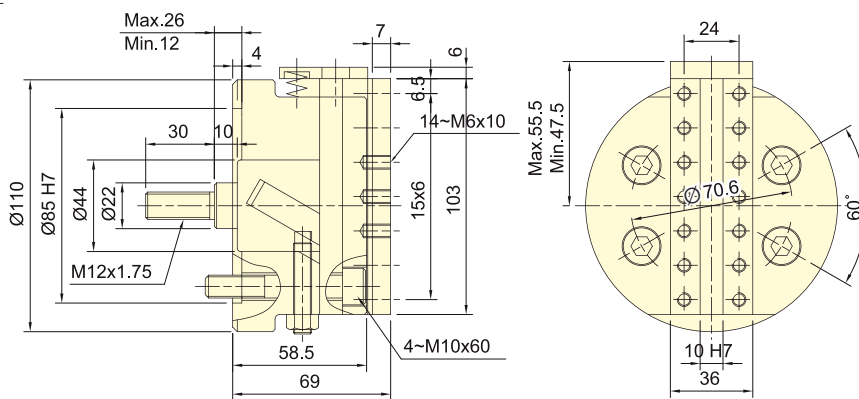

WEDGE PLUNGER
FA-610 FA-812

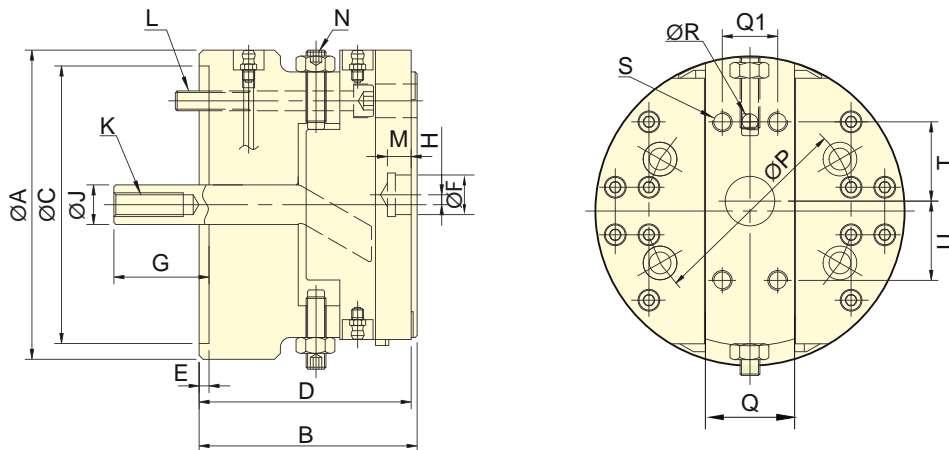

Subject to technical changes

SPECIFICATIONS

Model	Plunger stroke	Slider stroke	Max. speed	Max. D.B. PULL	Weight	Matching cylinder	Max. pressure
	mm	mm	min ⁻¹ (r.p.m.)	kN(kgf)	kg		MPa(kgf/cm ²)
FA-408	14	8	1600	2.8 (280)	4.2	RS-6520N	1.0(10)
Model	Plunger stroke	Slider stroke	Max. speed	Max. D.B. PULL	Weight	Matching cylinder	Max. pressure
	mm	mm	min ⁻¹ (r.p.m.)	kN(kgf)	kg		MPa(kgf/cm ²)
FA-610	18	10	1200	2.8 (280)	14.5	RS-6520N	1.0(10)
FA-812	21	12	800	4.4 (450)	28.5	RS-6530N	1.6(16)

DIMENSIONS

डिमेंशन	क	ख	ग	घ	ङ	च	छ	ज	झ	ट	ठ	ड	ढ	त	थ	द	ध	न	प		
FA-610	156	110	140	107	5	20	66	48	± 5	20	M12x1.75	4-M10x90	12	2-M10x45	104.8	45	28	8	4-M10x16	40	40
FA-812	198	130	170	127	5	25	84	63	± 6	25	M16x2.0	4-M12x105	12	2-M12x60	133.4	54	32	10	4-M10x16	50	50



- Feed mechanism is transmitted by Rack and Pinion with steady feed speed. Simple adjustment for feed speed and stroke.
- Matching surfaces of all parts hardened, grinding and lubricated directly. With rigidity and durability.
- Stopper accuracy: $\pm 0.03\text{mm}$, work with stoper screw.
- Suitable for using with RS type cylinder.

RACK AND PINION
FA-615 FA-830 FA-1570

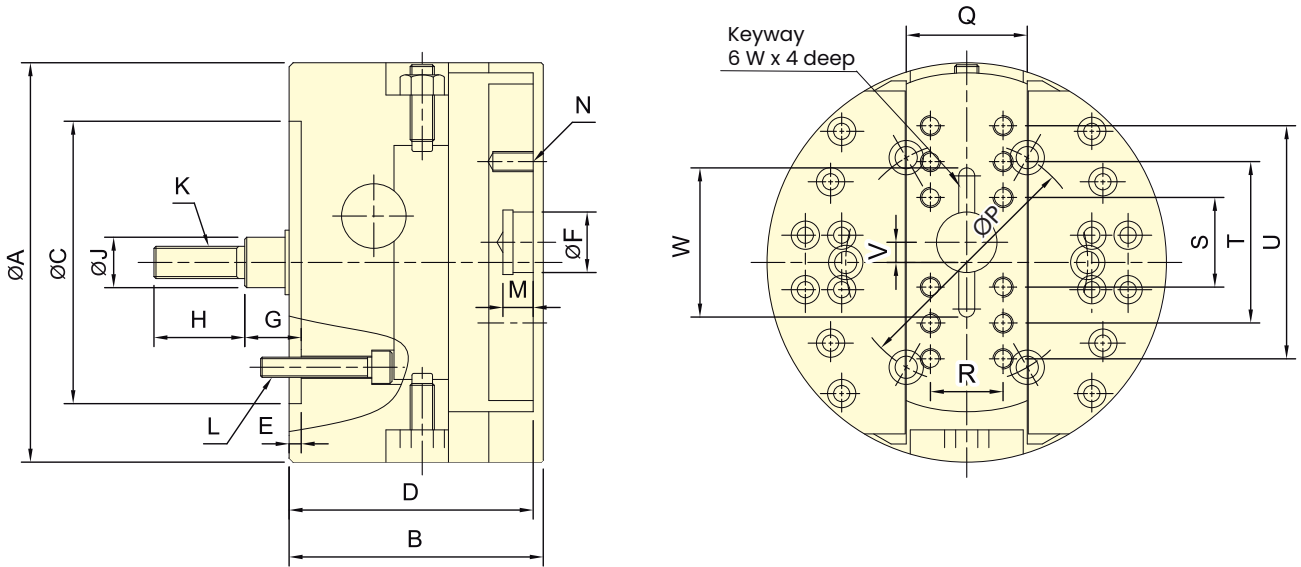

Subject to technical changes

SPECIFICATIONS

Model	Plunger stroke	Slider stroke	Max. speed	Max. D.B. PULL	Weight	Matching cylinder	Max. pressure
	mm	mm	min ⁻¹ (r.p.m.)	kN(kgf)	kg		MPa(kgf/cm ²)
FA-615	15	15	1200	3.3 (340)	11.9	RS-6520N	1.2(12)
FA-830	30	30	800	5.0 (510)	23.9	RS-6530N	1.8(18)
FA-1570	70	70	500	18.2 (1855)	167	RS-1080N	2.6(26)

DIMENSIONS

इंग्लिश	क	ख	ग	घ	ङ	च	छ	ज	झ	ट	
FA-615	150	107	110	102	5	25	40	25	35	20	M12x1.75
FA-830	198	126	140	121	6	30	54	24	45	25	M16x2
FA-1570	400	200	300	192	6	60	110	40	75	50	M30x3.5

इंग्लिश	ठ	ड	ढ	त	थ	द	ध	न	प	फ	ब
FA-615	3-M10x40	12	8-M8x16	82.6	50	32	32	68	-	± 7.5	56
FA-830	6-M10x55	15	12-M10x20	120	60	36	40	80	120	± 15	66
FA-1570	6-M20x90	15	8-M16x20	235	120	80	130	260	-	± 17.5	-

FACING HEADS



- Feed mechanism is transmitted by Crank with steady feed speed. Simple adjustment for feed speed and stroke.
- Matching surfaces of all parts hardened, grinding and lubricated directly. With rigidity and durability.
- Stopper accuracy: $\pm 0.03\text{mm}$, work with stoper screw.
- Suitable for using with RS type cylinder.

CRANK TYPE

FD-632 FD-840 FD-1060

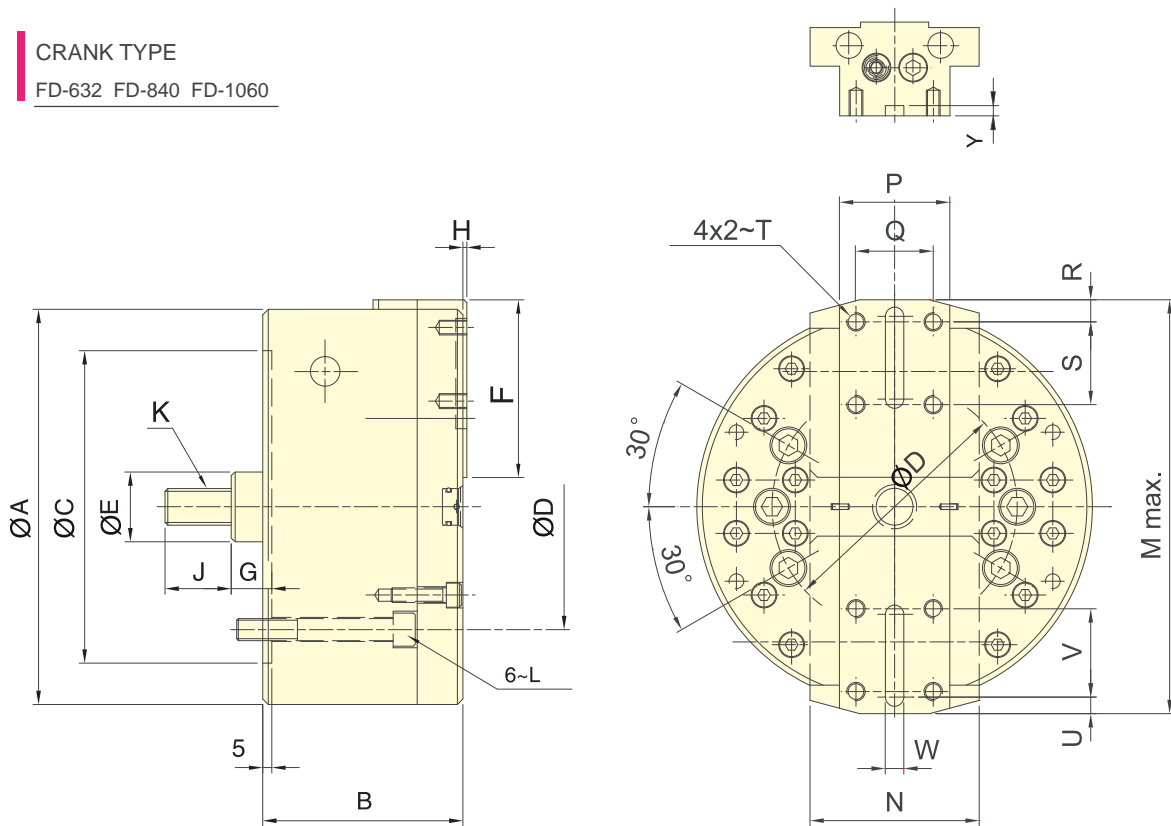

Subject to technical changes

SPECIFICATIONS

Model	Plunger stroke	Slider stroke(Dia.)	Max. speed	Max. D.B. PULL	Max. feed speed	Weight	Matching cylinder	Max. pressure
	mm	mm	min ⁻¹ (r.p.m.)	kN(kgf)	mm/min.	kg		MPa(kgf/cm ²)
FD-632	20	32	3200	16.9 (1720)	300	13.6	RS-1030N	2.4(24)
FD-840	25	40	2500	20.6 (2100)	240	30.0	RS-1030N	3.0(30)
FD-1060	35	60	1800	20.6 (2100)	200	41.5	RS-1040N	3.0(30)

DIMENSIONS

इंग्लिश	क	ख	ग	घ	ङ	च	छ	ज	झ	ट	
FD-632	168	93	140	104.8	32	76	31	11	2	36	M16x2.0
FD-840	215	109	170	133.4	38	96.5	32.5	7.5	2	36	M20x2.5
FD-1060	254	123	220	171.4	38	110.5	32.5	-2.5	4	36	M20x2.5

इंग्लिश	ठ	ड	ढ	त	थ	द	ध	न	प	फ	ब	म
FD-632	6~M10x75	188	70	40	25	10	32	M8x15	10	32	6	4
FD-840	6~M12x85	238	92	60	42	12	45	M10x15	12	45	10	6
FD-1060	6~M16x125	286	90	65	46	15	50	M10x15	12	50	10	6



- CRANK type 2-jaw synchronous clamp with long jaw stroke.
- Matching surfaces of all parts hardened, ground and lubricated directly.
- High rigidity and high clamping accuracy.

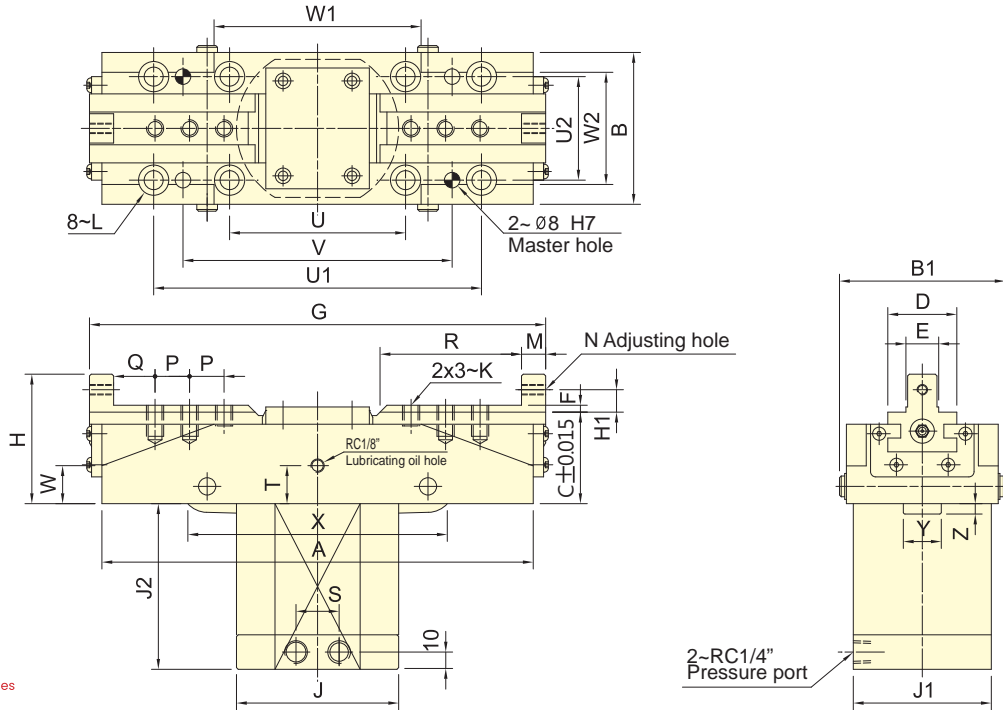

Subject to technical changes

SPECIFICATIONS

Model	Eff. Piston area		Jaw stroke(Dia.)	Clamping capacity	Max. clamping force	Max. pressure	Weight
	Extend	Retract					
	cm ²	cm ²	mm	mm	kN (kgf)	MPa(kgf/cm ²)	kg
CP-20	28.27	25.13	20	150	14.4(1465)	3.5(35)	9.5
CP-30A	28.27	25.13	30	180	14.4(1465)	3.5(35)	11
CP-30	28.27	25.13	30	210	14.4(1465)	3.5(35)	12
CP-40	28.27	25.13	40	200	14.4(1465)	3.5(35)	12
CP-50	38.48	33.57	50	215	17.7(1812)	3.5(35)	18.5
CP-70	50.26	45.35	70	235	23.9(2434)	3.5(35)	30

DIMENSIONS

Model	A	B	B1	C	D	E(h6)	F	G max.	Gmin	H	H1	J	J1	J2	K	L	M
CP-20	215	88	96	53	40	18	4	249	229	75	13	94	76	83.5	M10x1.5	M10	12
CP-30A	250	88	96	53	40	18	4	295	265	75	13	94	76	96	M10x1.5	M10	14
CP-30	280	88	96	53	40	22	4	327	297	75	13	94	76	96	M12x1.75	M10	14
CP-40	270	88	96	53	40	22	4	331	291	75	13	94	76	110	M12x1.75	M10	14
CP-50	300	110	115	65	50	28	5	369	319	90	15	105	105	120	M12x1.75	M10	16
CP-70	346	120	126	89	55	32	5	430	360	114	15	115	115	146	M14x2	M12	16

Model	N	P	Q	R	S	T	U	U1	U2	V	W	W1	W2	X	Y	Z
CP-20	M6x1	18	20	66	24	22	102	190	60	156	32	110	65	150	22	4
CP-30A	M6x1	20	24	96	24	22	102	190	60	156	20	120	65	156	22	6
CP-30	M6x1	20	24	98	24	22	102	190	60	156	23	110	65	156	22	6
CP-40	M6x1	20	24	98	24	22	102	190	60	156	25	110	65	150	22	10.5
CP-50	M8x1.25	21	28	102	30	32	105	230	85	195	29	140	80	180	30	10
CP-70	M8x1.25	23	28	112	30	52	120	275	95	240	42	155	90	210	34	23.5



- Constantly high clamping forces are ensured while machining.
- Compact design, suitable for milling machines or machining centers.
- With built-in cylinder, it could be either pneumatically or hydraulically operated.
- Plug & play, easy to install.

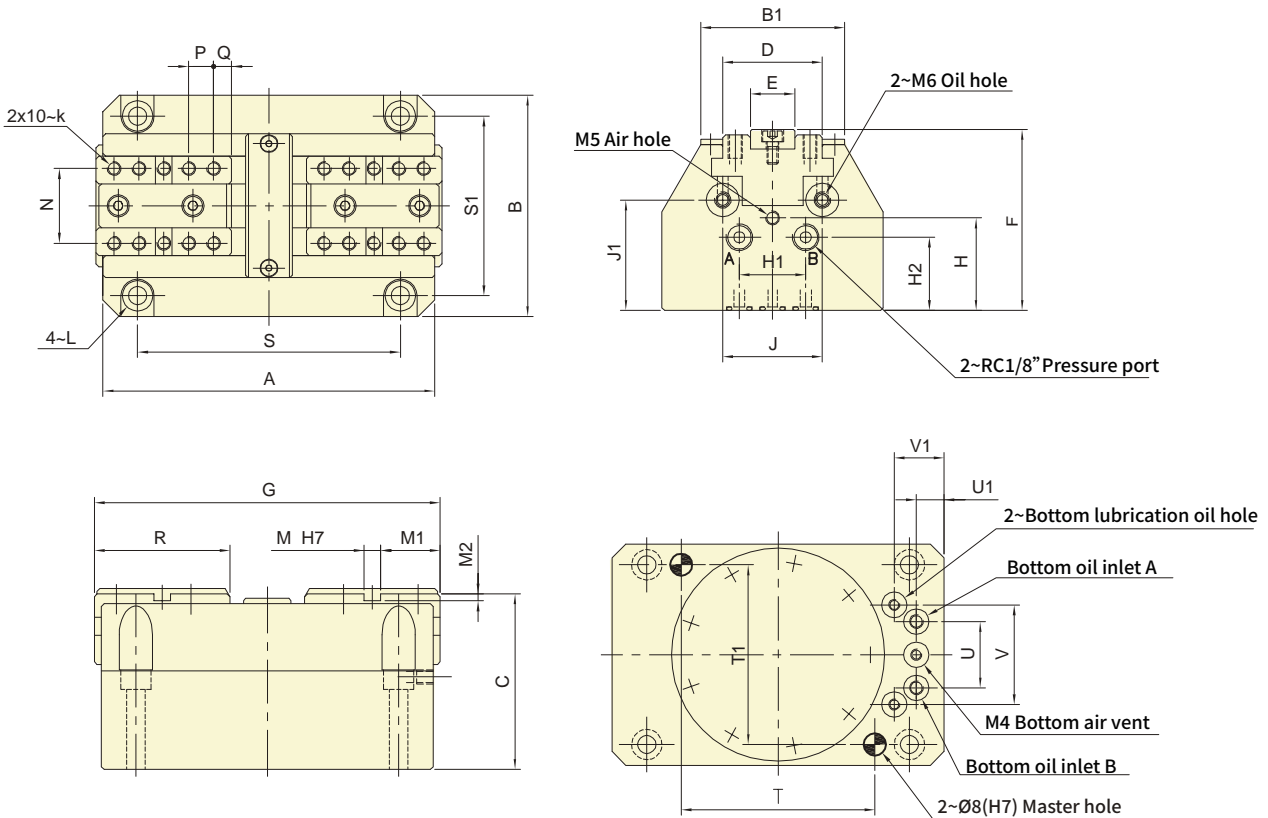

SYNCHRONOUS CLAMPS

保留規格修改的權利
Subject to technical changes

技術規格 SPECIFICATIONS

Model	Jaw stroke(Dia.) mm	Max.Chucking (Dia.) mm	Max. clamping force		Max. pressure		Weight kg
			Pneumatic	Hydraulic	Pneumatic	Hydraulic	
			kN (kgf)	kN (kgf)	MPa(kgf/cm ²)	MPa(kgf/cm ²)	
VR-808	8	100	2.0(200)	20.0(2040)	0.9(9)	7(70)	3.55

外型尺寸 DIMENSIONS

Model	A	B	B1	C	D	E(h6)	F	Gmax	Gmin	H	H1	H2	J	J1	K	L
VR-808	120	80	52	63.5	36	16	65.5	125	117	33.5	24	26.5	36	40	M5x0.8	M6
Model	M(H7)	M1	M2	N	P	Q	R	S	S1	T	T1	U	U1	V	V1	
VR-808	6	21.5	2.5	27	9	6.5	49	95	65	70	65	24	10	36	18	



- Super short form, light weight large Through-Hole, just as 2/3 of typical model length.
- Built-in safety check valves and pressure relief valves.
- Can screw it from the rear end of the cylinder when mounting.
- Linear sensor can be attached.(optional)
- Patent numbers :
PAT.NO.M491534(Taiwan)
PAT.NO.ZL201420584274.5(China)

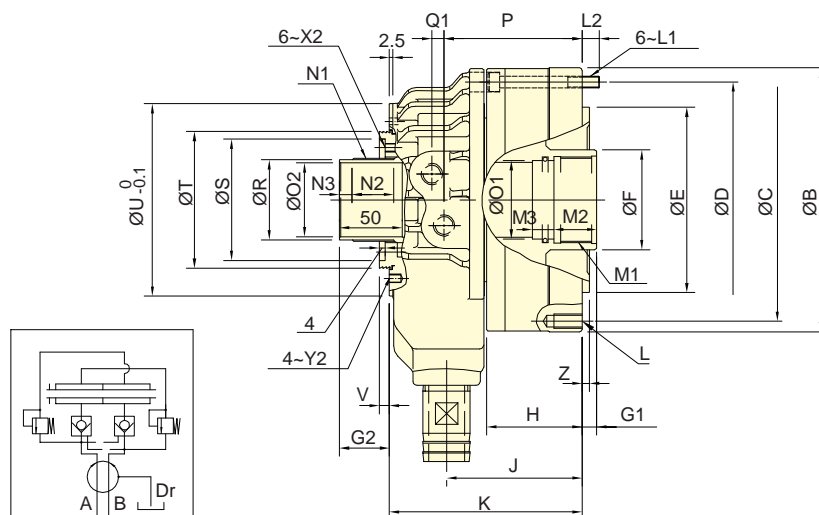
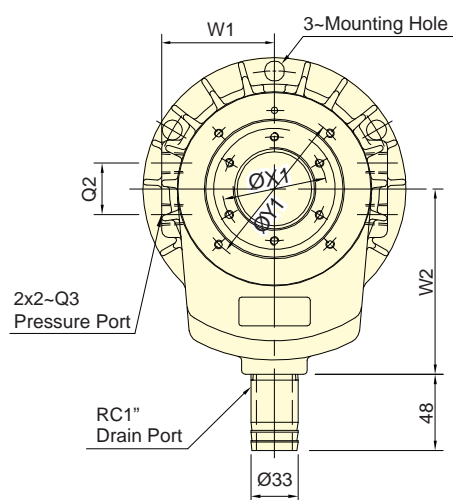

Subject to technical changes

SPECIFICATIONS

Model	Eff. piston area		Piston stroke	Max. speed	Max. pressure	Moment of inertia	Weight	Total oil leakage
	Extend	Retract						
	cm ²	cm ²						
TK-A528	73.0	69.7	12	8000	4.5 (45)	0.012	6.2	3.0
TK-A533	73.0	69.7	12	8000	4.5 (45)	0.012	6.0	3.0
TK-C643	99.1	88.0	15	7000	4.5 (45)	0.018	7.5	3.0
TK-A646	105.0	93.9	15	7000	4.5 (45)	0.018	7.3	3.0
TK-B646	105.0	93.9	15	7000	4.5 (45)	0.018	8.6	3.0
TK-C646	99.1	88.0	15	7000	4.5 (45)	0.018	7.5	3.0
TK-B846	135.3	125.0	20	6300	4.5 (45)	0.032	12.4	3.9
TK-A853	135.3	125.0	20	6300	4.5 (45)	0.032	11.8	3.9
TK-B853	135.3	125.0	20	6300	4.5(45)	0.032	11.7	3.9
TK-A1068	170.1	155.3	25	5500	4.5 (45)	0.065	19.2	4.2
TK-A1075	170.1	155.3	25	5500	4.5(45)	0.065	18.8	4.2
TK-A1078	170.1	155.3	25	5500	4.5 (45)	0.065	17.4	4.2

DIMENSIONS

Model	A	B	C	D	E	F	G1		G2		H	J	K	L	L1	L2	M1	M2	M3
	I.D.				h7		max.	min.	max.	min.									
TK-A528	105	141	125	125	110	45	12	0	38	26	49	77.5	123	6~M8x20	M8x55	14	M38x1.5	25	13
TK-A533	105	141	125	125	110	45	12	0	38	26	49	77.5	123	6~M10x20	M8x55	14	M38x1.5	25	13
TK-C643	128	156	140	140	120	65	15	0	44	29	56	85	125	12~M10x20	M8x60	12	M50x2	25	13
TK-A646	128	162	147	147	130	65	15	0	44	29	56	85	125	12~M10x20	M8x60	12	M55x2	25	13
TK-B646	128	162	130	147	100	65	15	0	44	29	66	95	135	12~M10x20	M8x70	12	M55x2	30	15
TK-C646	125	156	140	140	120	65	15	0	44	29	56	85	125	12~M10x20	M8x60	12	M55x2	25	13
TK-B846	145	185	170	165	130	70	20	0	48	28	66	95	135	12~M10x20	M8x70	12	M55x2	30	15
TK-A853	145	185	170	165	140	70	20	0	48	28	66	95	135	12~M10x20	M8x70	12	M60x2	30	15
TK-B853	145	185	170	165	130	70	20	0	48	28	66	95	135	12~M10x20	M8x70	12	M60x2	30	15
TK-A1068	170	212	190	190	160	95	25	0	50	25	74	108	158	12~M10x20	M10x80	16	M75x2	35	15
TK-A1075	170	212	190	190	160	95	25	0	50	25	74	108	158	12~M10x20	M10x80	16	M85x2	35	15
TK-A1078	170	212	190	190	160	95	25	0	50	25	74	108	158	12~M10x20	M10x80	16	M87x2	35	15

Model	N1	N2	N3	O1	O2	P	Q1	Q2	Q3	R	S	T	U	V	W1	W2	X1	X2	Y1	Y2	Z
				H8	H8					g7	H7										
TK-A528	M39x1.5	25	8	35	28	79	8.5	30	RC1/4	37	62	70	98	6	62	110	49	M6x6	83	M5x6	5
TK-A533	M39x1.5	25	8	35	33	79	8.5	30	RC1/4	37	62	70	98	6	62	110	49	M6x6	83	M5x6	5
TK-C643	M52x1.5	29	9	45	43	87	8.5	36	RC3/8	50	76	85	116	9.5	74	120	64	M6x10	98	M5x6	5
TK-A646	M52x1.5	29	9	50	46	87	8.5	36	RC3/8	50	76	85	116	9.5	74	120	64	M6x10	98	M5x6	5
TK-B646	M52x1.5	29	9	50	46	97	8.5	36	RC3/8	50	76	85	116	9.5	74	120	64	M6x10	98	M5x6	5
TK-C646	M52x1.5	29	9	50	46	87	8.5	36	RC3/8	50	76	85	116	9.5	74	120	64	M6x10	98	M5x6	5
TK-B846	M58x1.5	30	8	50	46	97	8.5	36	RC3/8	56	85	96	128	11.5	79	130	73	M6x12	110	M6x6	5
TK-A853	M58x1.5	30	8	55	53	97	8.5	36	RC3/8	56	85	96	128	11.5	79	130	73	M6x12	110	M6x6	5
TK-B853	M58x1.5	30	8	55	53	97	8.5	36	RC3/8	56	85	96	128	11.5	79	130	73	M6x12	110	M6x6	5
TK-A1068	M84x2	34	9	70	68	110	12	40	RC1/2	81	108	121	164	10	98	160	98	M6x12	155	M6x8	5
TK-A1075	M84x2	34	9	80	75	110	12	40	RC1/2	81	108	121	164	10	98	160	98	M6x12	155	M6x8	5
TK-A1078	M84x2	34	9	82	78	110	12	40	RC1/2	81	108	121	164	10	98	160	98	M6x12	155	M6x8	5

*Coolant Collector and Confirmation Device Please See Accessories pages.



- Super short form, light weight large Through-Hole, just as 2/3 of typical model length.
- Built-in safety check valves and pressure relief valves.
- Can screw it from the rear end of the cylinder when mounting.
- Linear sensor can be attached.(optional)
- Patent numbers :
PAT.NO.M491534(Taiwan)
PAT.NO.ZL201420584274.5(China)

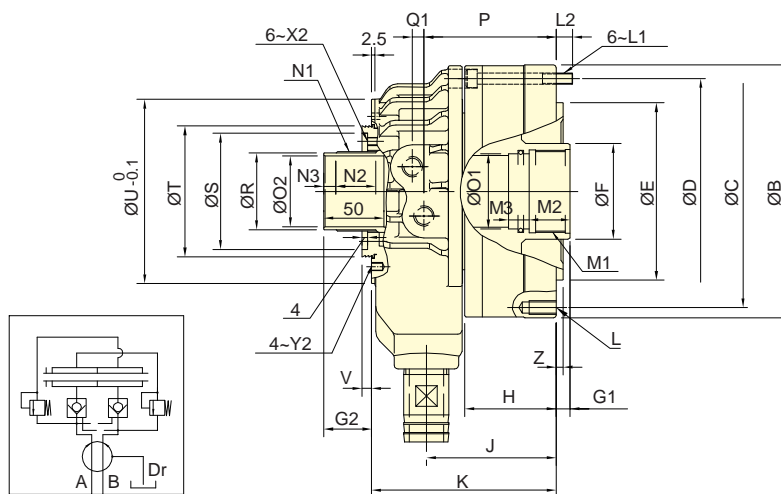
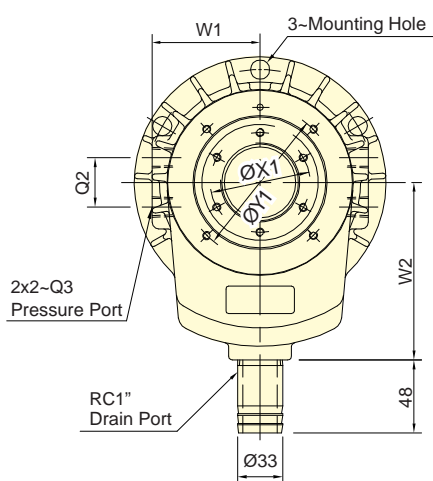

Subject to technical changes

SPECIFICATIONS

Model	Eff. piston area		Piston stroke	Max. speed	Max. pressure	Moment of inertia	Weight	Total oil leakage
	Extend	Retract						
	cm ²	cm ²	mm	min ⁻¹ (r.p.m.)	MPa(kgf/cm ²)	kg · m ²	kg	lit. / min.
TK-A1287	234.0	217.5	30	3800	4.0 (40)	0.092	24.8	4.5
TK-A1291	234.0	217.5	30	3800	4.0 (40)	0.092	24.8	4.5
TK-A1511	336.4	315.2	30	3000	3.5(35)	0.38	57.9	7.0
TK-A1512	336.4	315.2	30	3000	3.5(35)	0.38	53.8	7.0
TK-2114	373.2	336.1	35	2500	3.0 (30)	0.54	58.2	8.0

DIMENSIONS

Model	A	B	C	D	E	F	G1		G2		H	J	K	L	L1	L2	M1	M2	M3	N1
	I.D.				h7		max.	min.	max.	min.										
TK-A1287	200	245	215	225	180	110	30	0	59	29	86	126	184	12~M12x24	M10x90	14.5	M95x2	35	15	M99x2
TK-A1291	200	245	215	225	180	110	30	0	59	29	86	126	184	12~M12x24	M10x90	14.5	M100x2	35	15	M99x2
TK-A1511	250	300	275	275	230	140	30	0	58	28	102	156	226	12~M16x36	M12x110	21	M120x2	45	15	M129x2
TK-A1512	250	300	275	275	230	140	30	0	58	28	102	156	226	12~M16x36	M12x110	21	M130x2	45	15	M129x2
TK-2114	265	320	295	295	240	165	35	0	60	25	115	173.5	247.5	12~M16x32	M12x120	17.5	M155x2	45	20	M149x2

Model	N2	N3	O1	O2	P	Q1	Q2	Q3	R	S	T	U	V	W1	W2	X1	X2	Y1	Y2	Z
			H8	H8					g7	H7										
TK-A1287	38	9	90	87	127.5	15	45	RC1/2	96	120	138	180	7	110	185	108	M6x10	165	M6x10	5
TK-A1291	38	9	95	91	127.5	15	45	RC1/2	96	120	138	180	7	110	185	108	M6x10	165	M6x10	5
TK-A1511	38	9	115	110	153.75	17	50	RC1/2	126	150	170	227	7	134	210	138	M6x10	210	M6x9	6
TK-A1512	38	9	125	120	153.75	17	50	RC1/2	126	150	170	227	7	134	210	138	M6x10	210	M6x9	6
TK-2114	38	9	145	140	170	17	50	RC1/2	146	170	190	250	7	145	210	160	M6x10	230	M6x10	6

*Coolant Collector and Confirmation Device Please See Accessories pages.



- New design, short form, light weight large through-hole.
- Built-in safety check valves and pressure relief valves.
- Linear sensor can be attached.(optional)
- Patent numbers :
PAT.NO.M491534(Taiwan)
PAT.NO.ZL201420584274.5(China)

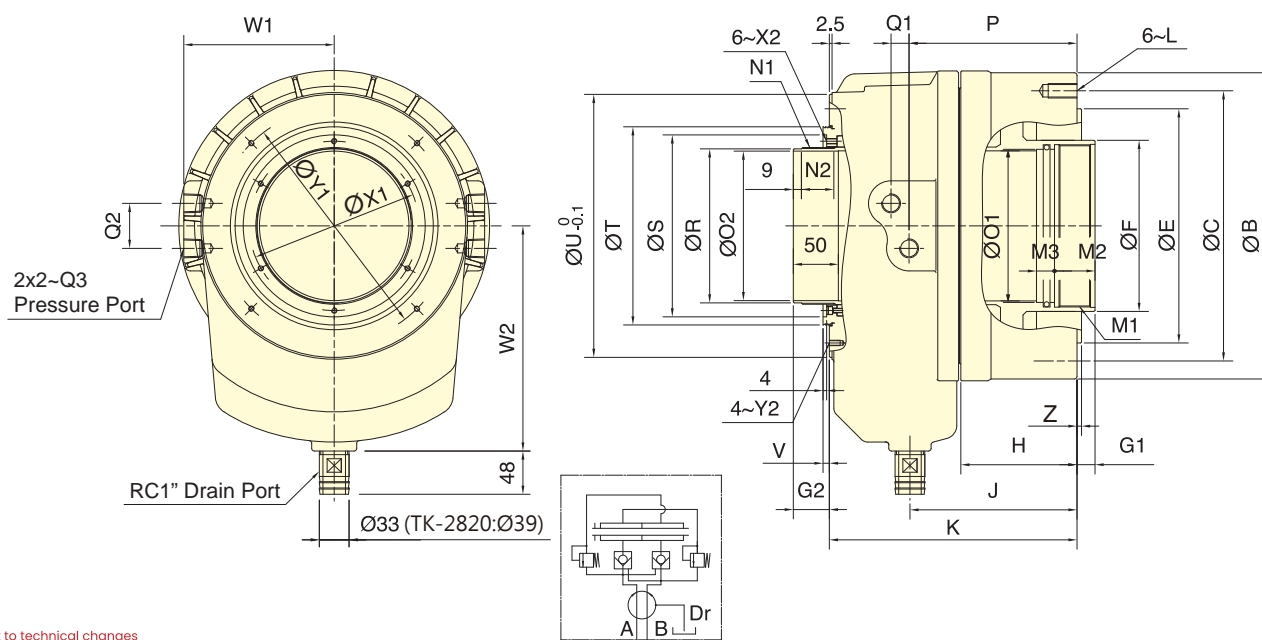

Subject to technical changes

SPECIFICATIONS

Model	Eff. piston area		Piston stroke	Max. speed	Max. pressure	Moment of inertia	Weight	Total oil leakage
	Extend	Retract						
	cm ²	cm ²	mm	min ⁻¹ (r.p.m.)	MPa(kgf/cm ²)	kg · m ²	kg	lit. / min.
TK-2416	418.4	375.4	35	2000	3.0 (30)	1.12	78.0	9.0
TK-2416L	418.4	375.4	51	2000	3.0 (30)	1.31	79.2	9.0
TK-2820	526.2	472.6	51	1600	3.0 (30)	2.4	134.0	10.0

DIMENSIONS

Model	A	B	C	E	F	G1		G2		H	J	K	L	M1	M2	M3	N1	N2
	I.D.			h7		max.	min.	max.	min.									
TK-2416	290	340	300	260	190	35	0	60	25	129	185.5	275	M16x32	M180x3	45	20	M174x2	38
TK-2416L	290	340	300	260	190	51	0	76	25	145	201.5	291	M16x32	M180x3	45	20	M174x2	52
TK-2820	340	395	360	320	235	51	0	76	25	152	212.5	316	M20x40	M220x3	45	20	M218x2	52

Model	O1	O2	P	Q1	Q2	Q3	R	S	T	U	V	W1	W2	X1	X2	Y1	Y2	Z
	H8	H8					g7	H7										
TK-2416	170	166	186.5	20	50	RC1/2	171	202	220	292	7	167	250	188	M6x11	260	M6x12	5
TK-2416L	170	166	202.5	20	50	RC1/2	171	202	220	292	7	167	250	188	M6x11	260	M6x12	6
TK-2820	210	205	216	21	50	RC1/2	215	262	285	360	7	202.5	300	240	M6x12	320	M6x12	6

*Coolant Collector and Confirmation Device Please See Accessories pages.



- Bigger bore through-hole design. Super short form, light weighted.
- Built-in safety check valves and pressure relief valves.
- Front/Rear end mounting.
- Diameter of coolant collector's drain port is optional. Default : $\varnothing 33$; optional : $\varnothing 40, \varnothing 60$.
- Linear sensor can be attached. (optional)
- Patent numbers :
 PAT.NO.M491534(Taiwan)
 PAT.NO.ZL201420584274.5(China)

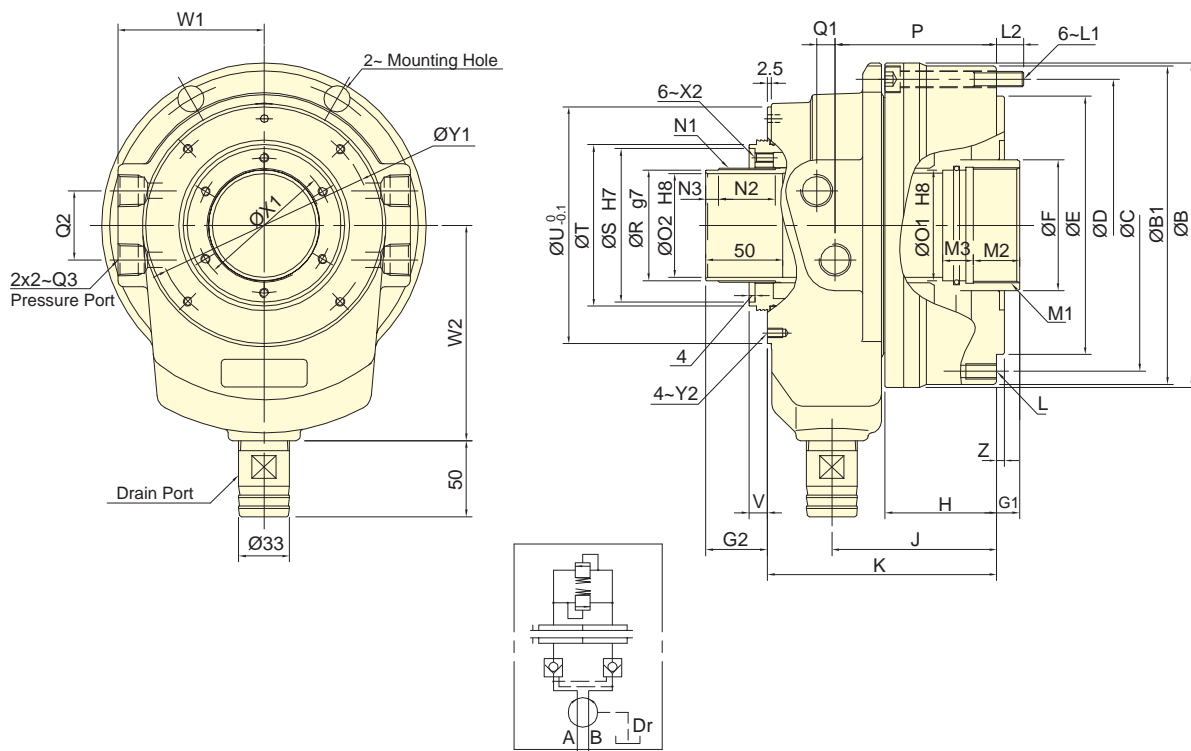

Subject to technical changes

SPECIFICATIONS

Model	Eff. piston area		Piston stroke	Max. speed	Max. pressure	Moment of inertia	Weight	Total oil leakage
	Extend	Retract						
	cm ²	cm ²	mm	min ⁻¹ (r.p.m.)	MPa(kgf/cm ²)	kg · m ²	kg	lit. / min.
TS-539	72.4	67.1	15	8000	4.5(45)	0.012	6.9	3.0
TS-866	168.0	155.5	25	5600	4.5(45)	0.056	16.3	4.0
TS-1081	189.2	174.3	25	4800	4.5(45)	0.085	21.2	4.3

DIMENSIONS

Model	A	B	Bl	C	D	E	F	G1		G2		H	J	K	L	L1	L2	M1	M2	M3
	I.D.	h7	max.	min.	max.	min.														
TS-539	107	143	141	125	125	110	52	15	0	42.5	27.5	57	91	124	6-M10x20	M8x60	12	M45x1.5	25	12
TS-866	165	211	207	190	190	168	85	25	0	55	30	72.5	107	149	12-M10x20	M10x80	17.5	M75x2	35	15
TS-1081	180	226	222	205	205	168	100	25	0	58	33	74	115	166	12-M10x20	M10x80	16	M90x2	35	15

Model	N1	N2	N3	O1	O2	P	Q1	Q2	Q3	R	S	T	U	V	W1	W2	X1	X2	Y1	Y2	Z
				(H8)	(H8)					(g7)	(H7)										
TS-539	M44x1.5	26	8	42	39	85	8.5	30	RC1/4	42	69	72	103	10	62.5	100	54	M6x10	90	M5x12	5
TS-866	M74x1.5	37	8	72	66.5	105	12	45	RC1/2	72	100	111	154	12	95	140	88	M6x12	140	M6x10	5
TS-1081	M89X2.0	38	9	85	81	109	15	45	RC1/2	86	113	123	175	16	103	160	103	M6x12	160	M6X10	5

*Coolant Collector and Confirmation Device. Please See Accessories pages.

- Super high speed, light weight large Through-Hole.
- Built-in check valve which prevents the internal pressure from sudden declining so that the workpiece will not fly out and cause a serious accident.
- Linear sensor can be attached.(optional)

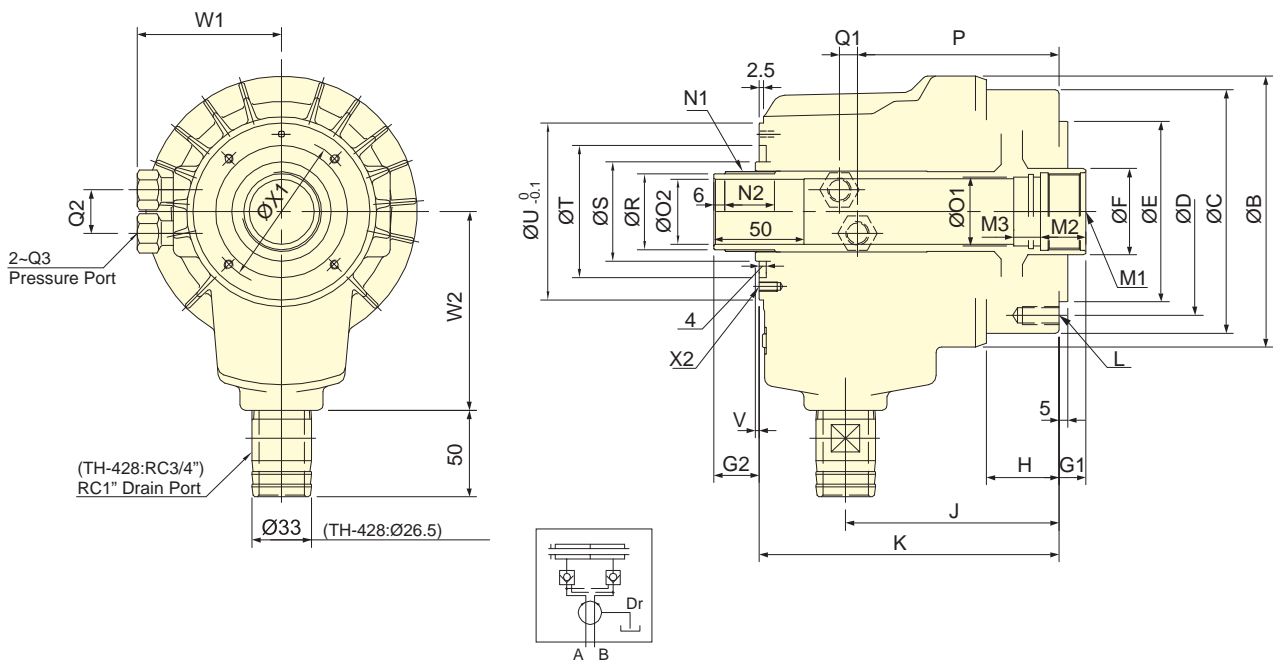

Subject to technical changes

SPECIFICATIONS

Model	Eff. piston area		Piston stroke	Max. speed	Max. pressure	Moment of inertia	Weight	Total oil leakage
	Extend	Retract						
	cm ²	cm ²						
TH-428	53.2	50.5	10	8000	4.0(40)	0.008	5.8	3.0
TH-A536	69.8	67.5	15	8000	4.0(40)	0.05	8.3	3.0

DIMENSIONS

Model	A I.D.	B	C	D	E (h7)	F	G1 max.	G1 min.	G2 max.	G2 min.	H	J	K	L	M1	M2	M3
TH-428	90	130	120	100	80	40	10	0	35	25	45	127.5	155	6-M8x15	M33x1.5	25	12
TH-A536	105	150	135	115	100	48	15	0	40	25	40	118	166	6-M10x20	M42x1.5	25	15

Model	N1	N2	O1 (H8)	O2 (H8)	P	Q1	Q2	Q3	R (g7)	S	T	U	V	W1	W2	X1	X2
TH-428	M34x1.5	26	30	28	101.5	11	24	RC1/4	32	45	65	86	4	72	105	76	M4x7
TH-A536	M44x1.5	28	38	36	111.5	10	24	RC1/4	42	55	73	98	4	80	110	83	M5x10

*Coolant Collector and Confirmation Device Please See Accessories pages.



- This is a compact, short form, light weight through-hole rotary cylinder.
- With patented build-in safety check valves and pressure relief valves.
- Large feed port and drain port, large input and keep drain smoothly.
- Can be screwed from the front end or rear end of cylinder when mounting.
- For use with vertical or horizontal spindles.
- Linear sensor can be attached.(optional)
- Patent numbers :
PAT.NO.M491534(Taiwan)
PAT.NO.ZL201420584274.5(China)

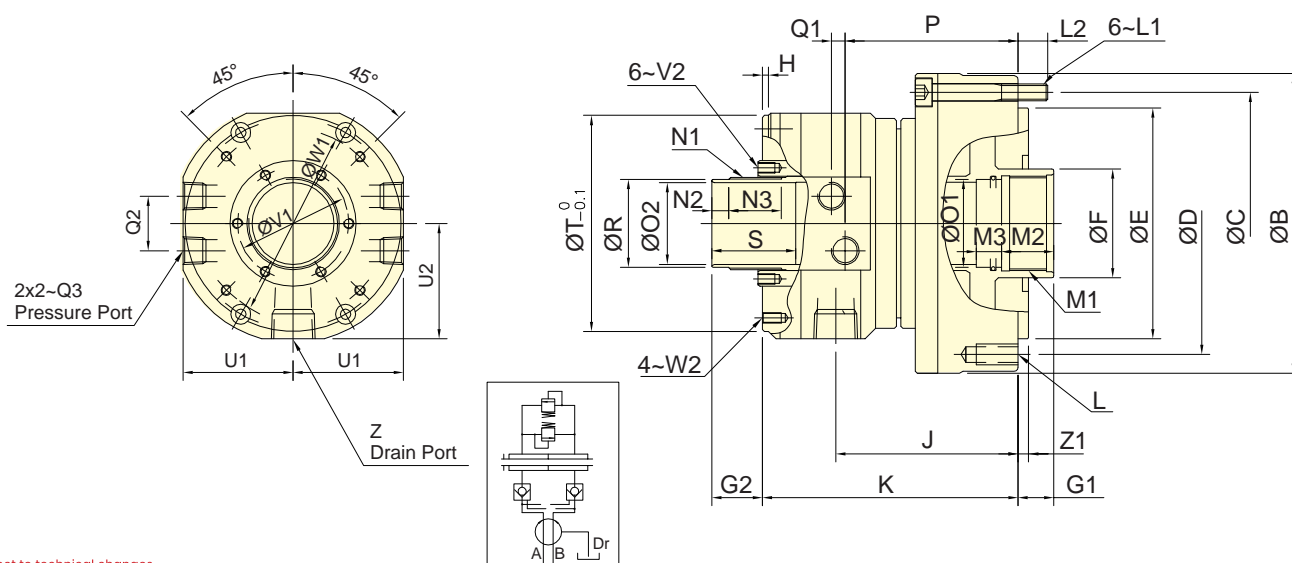

Subject to technical changes

SPECIFICATIONS

Model	Eff. piston area		Piston stroke	Max. speed	Max. pressure	Moment of inertia	Weight	Total oil leakage
	Extend	Retract						
	cm ²	cm ²						
TR-539	72.4	67.1	15	8000	4.0(40)	0.010	6.8	3.0
TR-646	105.0	93.9	15	7000	4.0(40)	0.015	9.5	3.0
TR-853	135.3	125	20	6300	4.0(40)	0.032	11.5	3.9
TR-1075	170	155	25	4500	4.0(40)	0.065	18	4.2

DIMENSIONS

Model	A	B	C	D	E	F	G1		G2		H	J	K	L	L1	L2	M1	M2	M3
	I.D.	h7	max.	min.	max.		min.												
TR-539	107	143	125	125	110	52	15	0	34	19	4	97	133	6-M10x20	M8x60	12	M45x1.5	25	12
TR-646	128	165	147	147	130	65	15	0	34	19	3.5	97	135	12-M10x20	M8x60	11.5	M55x2	25	13
TR-853	145	185	165	170	130	70	20	0	47	27	4.5	118.5	160	12-M10x20	M8x75	12	M60x2	30	15
TR-1075	170	212	190	190	160	95	25	0	52	27	4.5	129.5	181	12-M10x20	M10x1.5	16	M85x2	35	15

Model	N1	N2	N3	O1	O2	P	Q1	Q2	Q3	R	S	T	U1	U2	V1	V2	W1	W2	Z	Z1
				H8	H8					g7										
TR-539	M44x1.5	8	25	42	39	92.5	6.5	26	RC 1/4	42	40	103	52.5	55	53	M5x8	90	M5x9	RC 1/2	5
TR-646	M52x1.5	8	25	50	46	95	5	32	RC 3/8	50	50	116	59	62	61.5	M5x9	98	M5x9	RC 1/2	5
TR-853	M58x1.5	8	30	55	53	114	8	34	RC 3/8	56	50	128	65	67	70	M5x10	110	M6x11	RC 1/2	5
TR-1075	M84x2	9	33	80	75	123.5	12	40	RC 1/2	81	50	164	83	86	95	M5x10	155	M6x11	RC 3/4	5

*Coolant Collector and Confirmation Device Please See Accessories pages.

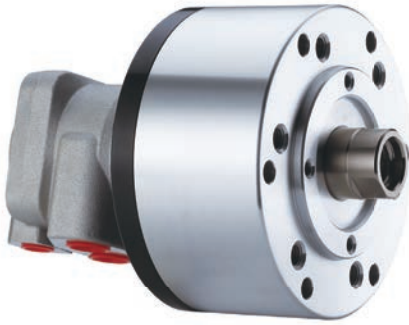

- For short form, light weight and high speed rotary cylinder.
- Built-in safety check valves and pressure relief valves.
- Can screw it from the rear end of the cylinder when mounting.
- The drain port should be independently connected to oil tank to avoid back pressure.

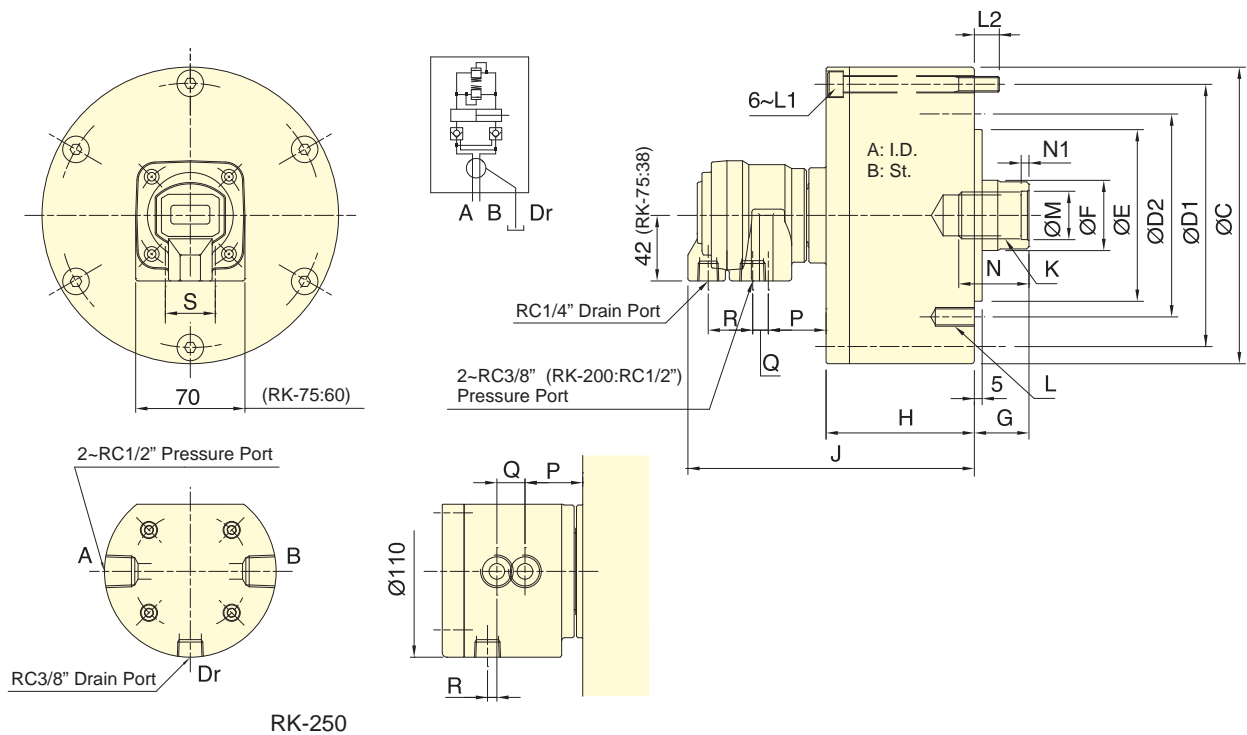
RK-250

Subject to technical changes

SPECIFICATIONS

Model	Eff. piston area		Piston stroke	Max. speed	Max. pressure	Moment of inertia	Weight
	Extend	Retract					
	cm ²	cm ²	mm	min ⁻¹ (r.p.m.)	MPa(kgf/cm ²)	kg · m ²	kg
RK-75	44.2	37.1	15	6000	4.0 (40)	0.01	2.9
RK-100	78.5	71.5	20	6000	4.0 (40)	0.03	4.4
RK-125	122.7	113.1	25	6000	4.0 (40)	0.05	6.9
RK-150	176.7	160.8	30	5500	4.0 (40)	0.09	9.5
RK-200	314.1	290.4	35	5500	4.0 (40)	0.28	15.4
RK-250	469.1	436.0	60	2000	5.0(50)	0.40	45.2

DIMENSIONS

Model	A	B	C	D1	D2	E (h7)	F	G max.	G min.	H	J	K	L	L1	L2	M (H8)	N	N1	P	Q	R	S
RK-75	75	15	107	90	90	65	30	45	30	57	148	M20x2.5	6-M8x16	M8x60	12	21	35	5	41.5	10	27.5	26
RK-100	100	20	132	115	100	80	30	45	25	72	163	M20x2.5	6-M10x20	M8x75	12	21	35	5	39.5	10	28.5	32
RK-125	125	25	160	140	130	110	35	50	25	82	172	M24x3.0	6-M12x20	M8x85	12	25	45	5	38.5	10	28.5	32
RK-150	150	30	190	170	130	110	45	55	25	95	184	M30x3.5	12-M12x24	M10x100	16	32	45	5	37	10	28.5	32
RK-200	200	35	245	220	145	120	55	70	35	115	201	M36x4.0	12-M16x30	M10x125	21	38	60	5	38	6	28.5	28
RK-250	245	60	307	275	220	160	65	85	25	165	255	M42x3.0	12-M20x35	M16x175	28	45	65	12	33	18	6	-

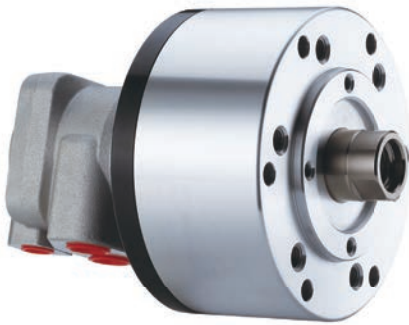

- For short form, light weight and high speed rotary cylinder.
- Can screw it from the rear end of the cylinder when mounting.
- The drain port should be independently connected to oil tank to avoid back pressure.

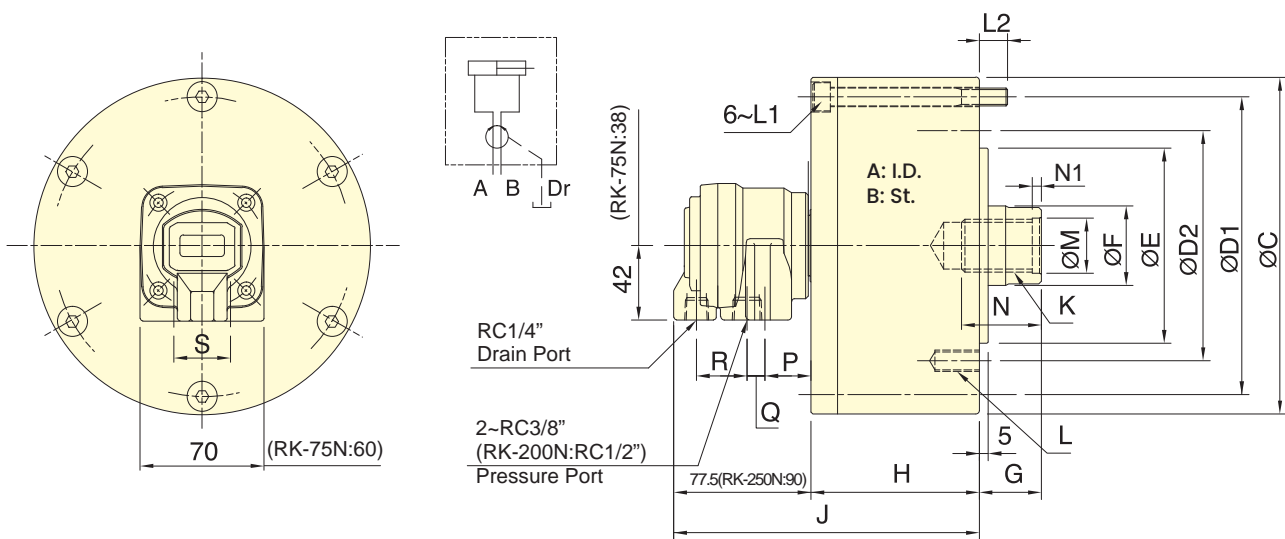

Subject to technical changes

SPECIFICATIONS

Model	Eff. piston area		Piston stroke	Max. speed	Max. pressure	Moment of inertia	Weight
	Extend	Retract					
	cm ²	cm ²					
RK-75N	44.2	37.1	15	6000	4.0(40)	0.01	2.8
RK-100N	78.5	71.5	20	6000	4.0(40)	0.03	4.3
RK-125N	122.7	113.1	25	6000	4.0(40)	0.05	6.8
RK-150N	176.7	160.8	30	5500	4.0(40)	0.09	9.4
RK-200N	314.1	290.4	35	5500	4.0(40)	0.28	15.3
RK-250N	469.1	436.0	60	2000	5.0(50)	0.40	45.2

DIMENSIONS

Model	A	B	C	D1	D2	E (h7)	F	G max.	G min.	H	J	K	L	L1	L2	M (H8)	N	N1	P	Q	R	S
RK-75N	75	15	107	90	90	65	30	45	30	57	134.5	M20x2.5	6~M8x16	M8x60	12	21	35	5	28	10	27.5	26
RK-100N	100	20	132	115	100	80	30	45	25	72	149.5	M20x2.5	6~M10x20	M8x75	12	21	35	5	26	10	28.5	32
RK-125N	125	25	160	140	130	110	35	50	25	82	159.5	M24x3.0	6~M12x20	M8x85	12	25	45	5	26	10	28.5	32
RK-150N	150	30	190	170	130	110	45	55	25	95	172.5	M30x3.5	12~M12x24	M10x100	16	32	45	5	26	10	28.5	32
RK-200N	200	35	245	220	145	120	55	70	35	115	192.5	M36x4.0	12~M16x30	M10x125	21	38	60	5	30	6	28.5	28
RK-250N	245	60	307	275	220	160	65	85	25	165	255	M42x3.0	6~M20x2.5	M16x175	28	45	65	12	37	18	6	-



- The rotary valve and cylinder body, all made of special light alloy, light-weight.
- Through unique design, the rotary valve enables the inside bearing to get sufficient lubricating and cooling and endure high-speed rotary for longer service life.
- The drain port should be independently connected to oil tank to avoid back pressure.

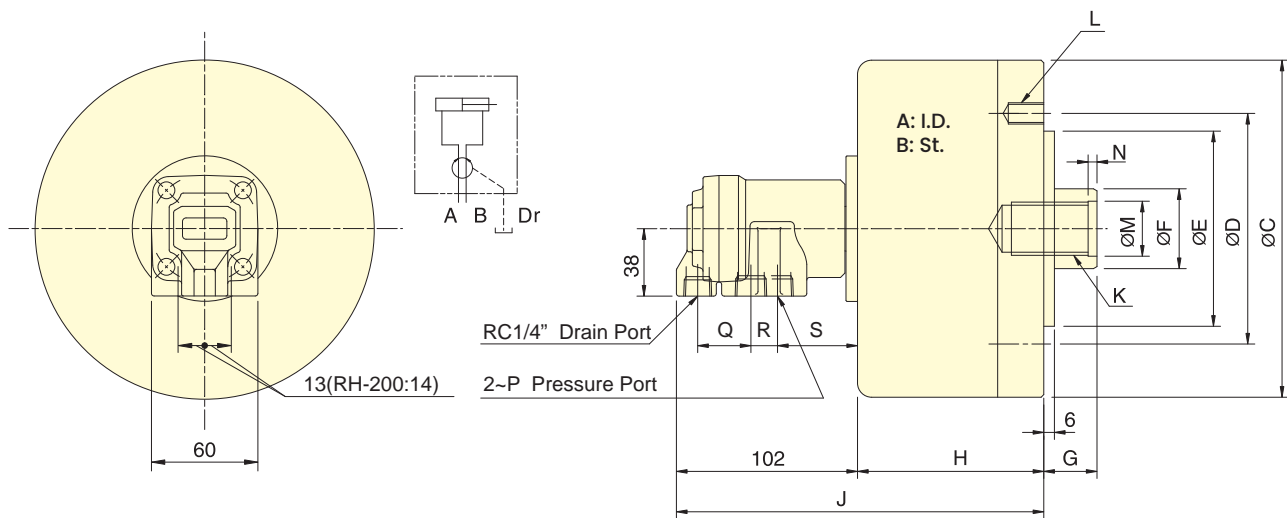

Subject to technical changes

SPECIFICATIONS

Model	Eff. piston area		Piston stroke	Max. speed	Max. pressure	Moment of inertia	Weight
	Extend	Retract					
	cm ²	cm ²					
RH-65	31.0	27.9	15	6000	3.5(35)	0.01	2.9
RH-80	47.7	42.8	15	6000	3.5(35)	0.01	3.4
RH-100	75.4	70.5	20	5500	3.5(35)	0.04	4.9
RH-125	119.6	112.5	25	5500	3.5(35)	0.08	6.8
RH-200	310.0	286.3	35	4000	4.0(40)	0.38	20.4

DIMENSIONS

Model	A	B	C	D	E (h7)	F	G max.	G min.	H	J	K	L	M (H8)	N	P	Q	R	S
RH-65	65	15	98	80	60	22	45	30	73	175	M12x1.75x30	6~M8x16	14	4	RC3/8	30	15	45
RH-80	80	15	112	90	65	25	45	30	74	176	M16x2.0x30	6~M8x16	17	4	RC3/8	30	15	45
RH-100	100	20	135	100	80	25	45	25	88.5	190.5	M16x2.0x30	6~M10x20	17	4	RC3/8	30	15	45
RH-125	125	25	160	130	110	30	50	25	95.5	197.5	M20x2.5x35	6~M12x20	21	4	RC3/8	30	15	45
RH-200	200	35	245	145	120	55	70	35	130	232	M36x4	12~M16x30	38	5	RC1/2	31	16	43



- The rotary valve and cylinder body, all made of special light alloy, are light-weight.
- Through unique design, the rotary valve can considerably reduce the waste in compressing air and efficiently increase its utilization.
- When used, a little oil mist should be contained.

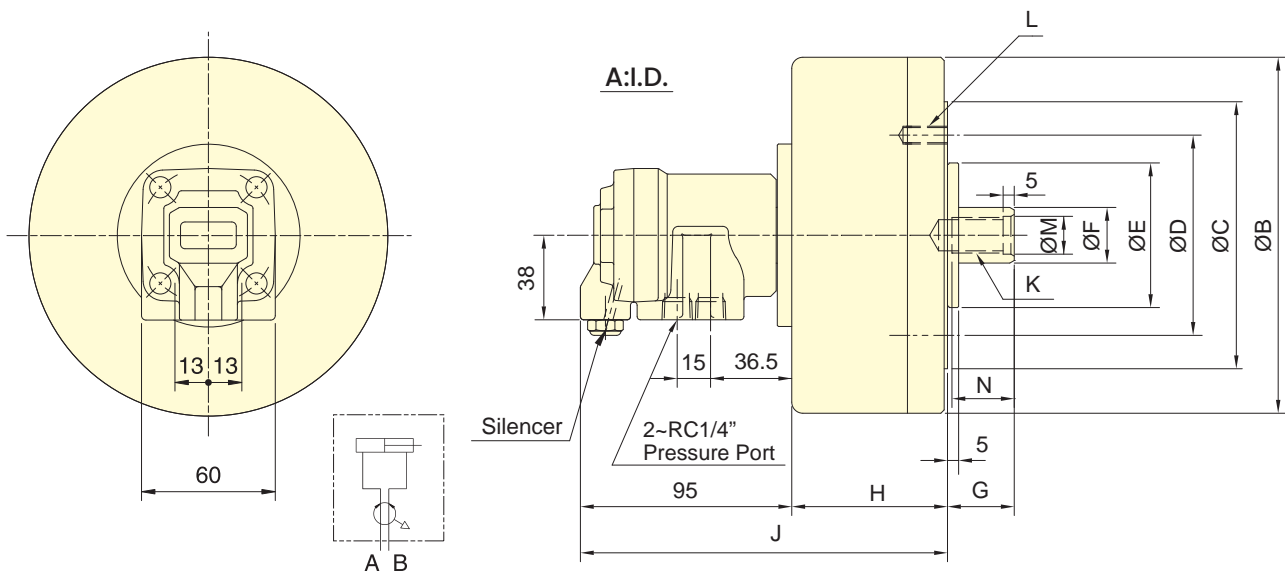

Subject to technical changes

SPECIFICATIONS

Model	Eff. piston area		Piston stroke mm	Max. speed min ⁻¹ (r.p.m.)	Max. pressure MPa(kgf/cm ²)	Moment of inertia kg · m ²	Weight kg	Air Leakage(6kgf/ cm ²) cc/sec
	Extend cm ²	Retract cm ²						
RA-100	77.0	74.4	15	6000	0.8(8)	0.03	3.9	400
RA-130	131.2	124.7	15	5000	0.8(8)	0.05	5.2	400
RA-170	225.4	219.0	20	5000	0.8(8)	0.18	8.5	400
RA-220	378.6	369.3	25	4000	0.8(8)	0.36	14.5	400
RA-270	571.0	562.9	30	3000	0.8(8)	0.75	18.4	400

DIMENSIONS

Model	A	B	C	D	E (h7)	F	G max.	G min.	H	J	K	L	M (H8)	N
RA-100	100	130	-	80	60	22	50	35	65	160	M12x1.75	6-M8x16	13	25
RA-130	130	160	120	90	65	25	45	30	70	165	M16x2.0	6-M8x16	17	30
RA-170	170	200	140	100	80	25	45	25	85	180	M16x2.0	6-M10x18	17	30
RA-220	220	255	170	130	110	30	50	25	91	186	M20x2.5	6-M12x20	21	35
RA-270	270	305	190	130	110	35	55	25	105	200	M24x3.0	6-M12x20	25	40

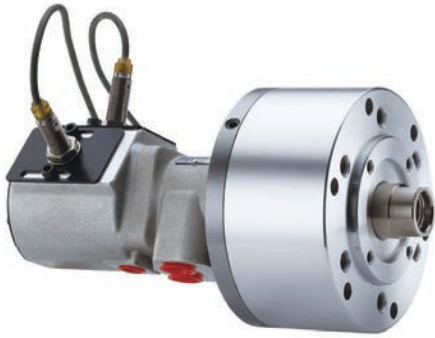

- For short form, high speed and stroke control.
- With proximity sensor, the movement of the position is easy to adjust and confirm when operating.
- Built-in safety check valves and pressure relief valves.
- Can screw it from the rear end of the cylinder when mounting.
- The drain port should be independently connected to oil tank to avoid back pressure.
- Stroke Detection Type can be customized to Linear Positioning System.

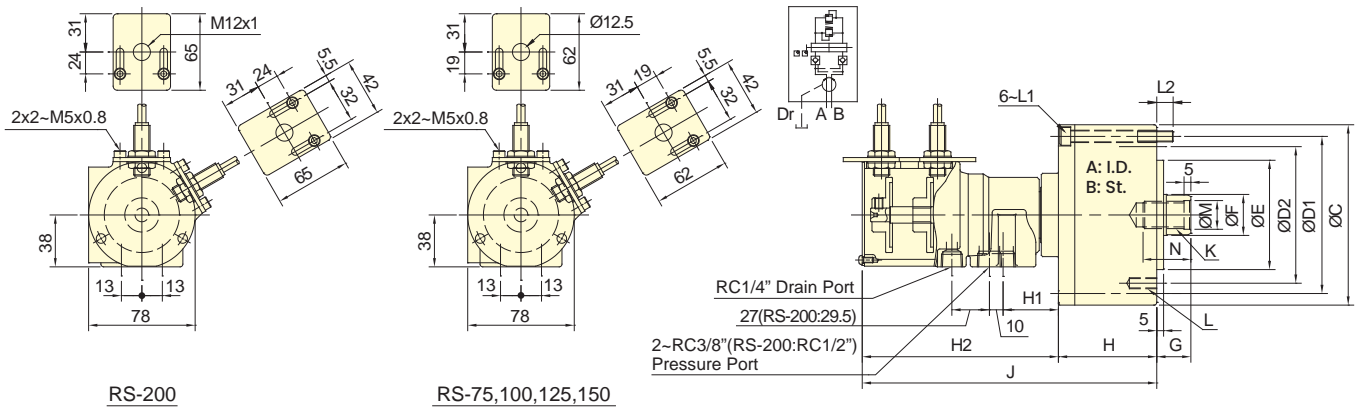

Subject to technical changes

SPECIFICATIONS

Model	Eff. piston area		Piston stroke mm	Max. speed min ⁻¹ (r.p.m.)	Max. pressure MPa(kgf/cm ²)	I Moment of inertia kg · m ²	Weight kg
	Extend cm ²	Retract cm ²					
RS-75	43.0	37.1	15	6000	4.0 (40)	0.01	3.4
RS-100	77.4	71.5	20	6000	4.0 (40)	0.04	4.9
RS-125	121.6	113.1	25	6000	4.0 (40)	0.05	7.4
RS-150	175.6	160.8	30	5500	4.0 (40)	0.10	10.7
RS-200	313.0	290.4	35	5500	4.0 (40)	0.29	15.9

DIMENSIONS

Model	A	B	C	D1	D2	E (h7)	F	G max.	G min.	H	H1	H2	J	K	L	L1	L2	M (H8)	N
RS-75	75	15	107	90	90	65	30	45	30	57	42	145	202	M20x2.5	6~M8x16	M8x60	12	21	35
RS-100	100	20	132	115	100	80	30	45	25	72	42	145	217	M20x2.5	6~M10x20	M8x75	12	21	35
RS-125	125	25	160	140	130	110	35	50	25	82	41	144	226	M24x3.0	6~M12x20	M8x85	12	25	45
RS-150	150	30	190	170	130	110	45	55	25	95	39	142	237	M30x3.5	12~M12x24	M10x100	16	32	45
RS-200	200	35	245	220	145	120	55	70	35	115	34	142.5	257.5	M36x4.0	12~M16x30	M10x125	21	38	60

*Proximity sensor : DC 10-30V 100mA NPN.

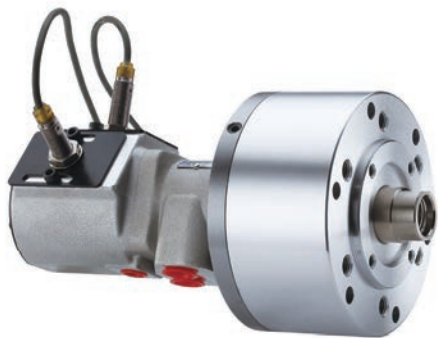

- For short form, high speed and stroke control.
- With proximity sensor, the movement of the position is easy to adjust and confirm when operating.
- Can screw it from the rear end of the cylinder when mounting.
- The drain port should be independently connected to oil tank to avoid back pressure.
- Stroke Detection Type can be customized to Linear Positioning System.

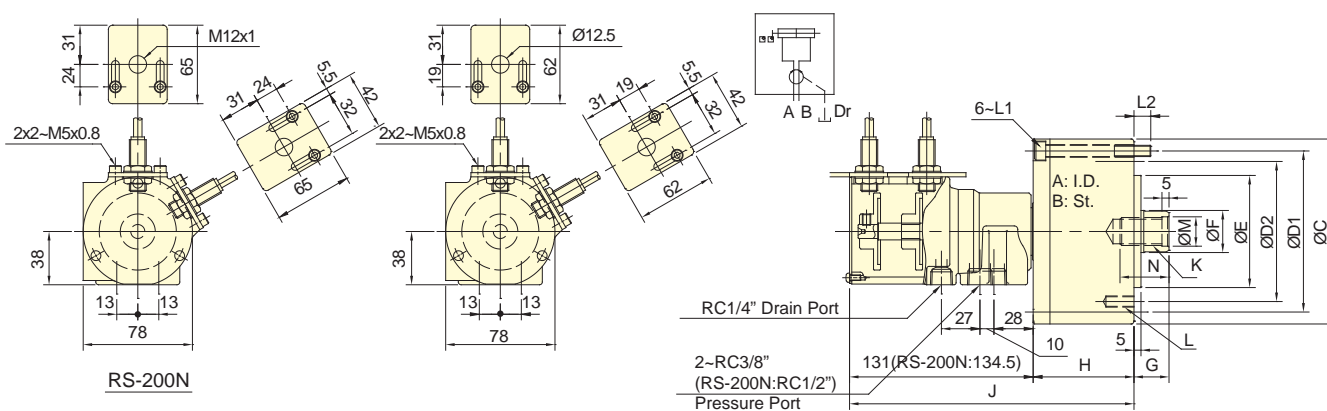

Subject to technical changes

SPECIFICATIONS

Model	Eff. piston area		Piston stroke	Max. speed	Max. pressure	I	Weight
	Extend	Retract					
	cm ²	cm ²				mm	
RS-6520N	32.0	28.3	20	6000	4.0(40)	0.01	3.2
RS-6530N	32.0	28.3	30	6000	4.0(40)	0.01	3.3
RS-75N	43.0	37.1	15	6000	4.0(40)	0.01	3.3
RS-7530N	43.0	37.1	30	6000	4.0(40)	0.013	3.7
RS-100N	77.4	71.5	20	6000	4.0(40)	0.04	4.8
RS-125N	121.6	113.1	25	6000	4.0(40)	0.05	7.3
RS-150N	175.6	160.8	30	5500	4.0(40)	0.16	10.6
RS-200N	313.0	290.4	35	5500	4.0(40)	0.29	15.9

DIMENSIONS

Model	A	B	C	D1	D2	E (h7)	F	G max.	G min.	H	J	K	L	L1	L2	M (H8)	N
RS-6520N	65	20	97	80	80	60	25	45	25	62	193	M16x2.0	6~M8x16	M6x70	14.5	17	30
RS-6530N	65	30	97	80	80	60	25	45	15	62	203	M16x2.0	6~M8x16	M6x80	14.5	17	30
RS-75N	75	15	107	90	90	65	30	45	30	57	188	M20x2.5	6~M8x16	M8x60	12	21	35
RS-7530N	75	30	107	90	90	65	30	45	15	72	203	M20x2.5	6~M8x16	M8x75	12	21	35
RS-100N	100	20	132	115	100	80	30	45	25	72	203	M20x2.5	6~M10x20	M8x75	12	21	35
RS-125N	125	25	160	140	130	110	35	50	25	82	213	M24x3.0	6~M12x20	M8x85	12	25	45
RS-150N	150	30	190	170	130	110	45	55	25	95	226	M30x3.5	12~M12x24	M10x100	16	32	45
RS-200N	200	35	245	220	145	120	55	70	35	115	249.5	M36x4.0	12~M16x30	M10x125	21	38	60

*Proximity sensor : DC 10~30V 100mA NPN.

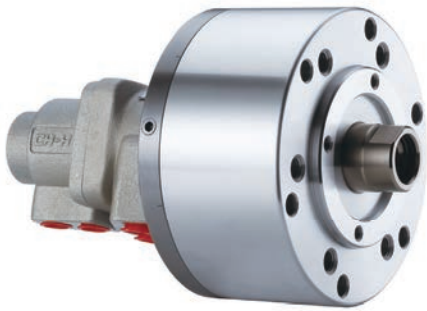

- To allow coolant to be feed from the rear end of the distributor through the rotating union
- Built-in safety check valves and pressure relief valves.
- The drain port should be independently connected to oil tank to avoid back pressure.
- The rotary cylinder should not run without liquid through coolant port.

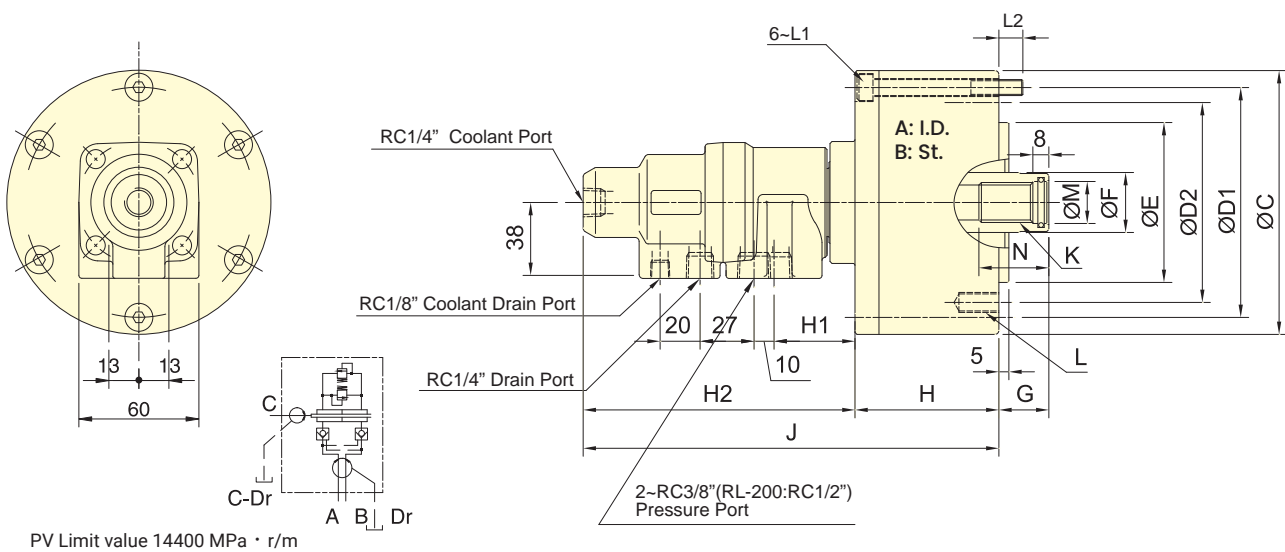

Subject to technical changes

SPECIFICATIONS

Model	Eff. piston area		Piston stroke	Max. speed	Max. pressure	Coolant connection Max. pressure	I		Weight
	Extend	Retract					Moment of inertia	kg · m ²	
	cm ²	cm ²							
RL-75	42.6	37.1	15	6000	4.0(40)	3.5(35)	0.01	3.1	
RL-100	77.0	71.5	20	6000	4.0(40)	3.5(35)	0.04	4.6	
RL-125	121.2	113.1	25	6000	4.0(40)	3.5(35)	0.06	7.1	
RL-150	175.2	160.8	30	5500	4.0(40)	3.5(35)	0.10	9.7	
RL-200	312.5	290.4	35	5500	4.0(40)	3.5(35)	0.30	15.6	

DIMENSIONS

Model	A	B	C	D1	D2	E (h7)	F	G max.	G min.	H	H1	H2	J	K	L	L1	L2	M (H8)	N
RL-75	75	15	107	90	90	65	30	45	30	57	42	137	194	M20x2.5	6~M8x16	M8x60	12	21	35
RL-100	100	20	132	115	100	80	30	45	25	72	42	137	209	M20x2.5	6~M10x20	M8x75	12	21	35
RL-125	125	25	160	140	130	110	35	50	25	82	41	136	218	M24x3.0	6~M12x20	M8x85	12	25	45
RL-150	150	30	190	170	130	110	45	55	25	95	39	134	230	M30x3.5	12~M12x24	M10x100	16	32	45
RL-200	200	35	245	220	145	120	55	70	35	115	36	132	248	M36x4.0	12~M16x30	M10x125	21	38	60

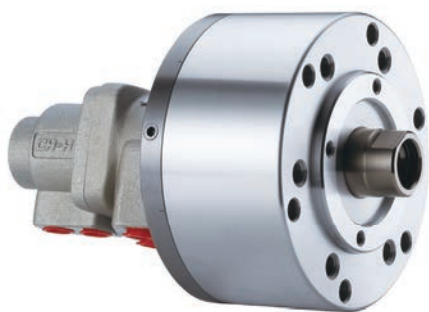

- To allow coolant to be feed from the rear end of the distributor through the rotating union.
- Can screw it from the rear end of the cylinder when mounting.
- The drain port should be independently connected to oil tank to avoid back pressure.
- The rotary cylinder should not run without liquid through coolant port.

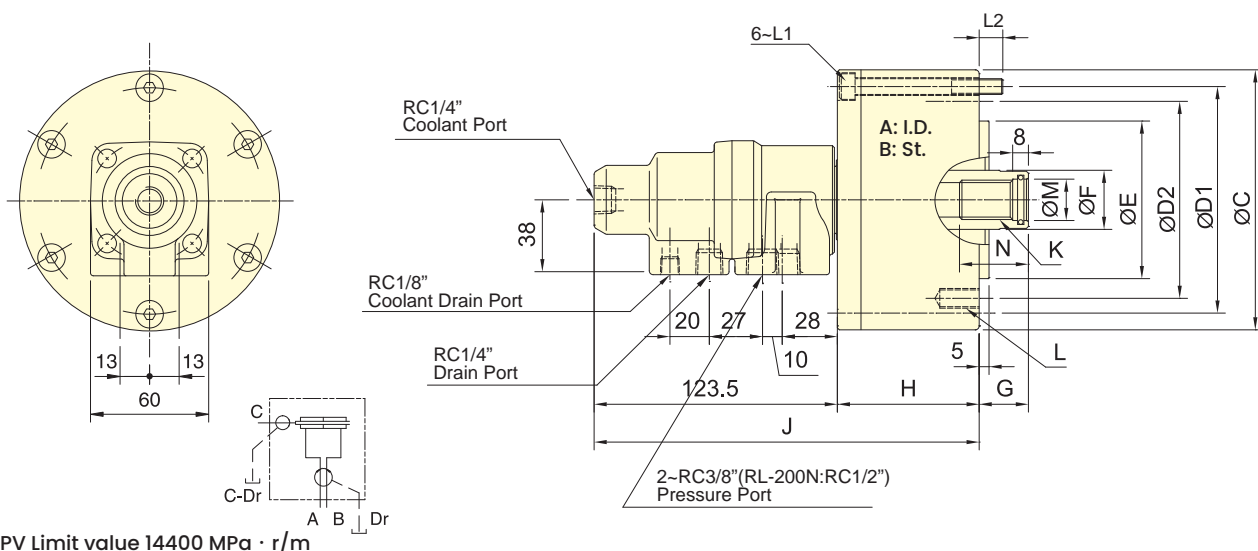

Subject to technical changes

SPECIFICATIONS

Model	Eff. piston area		Piston stroke	Max. speed	Max. pressure	Coolant connection Max. pressure	I Moment of inertia	Weight
	Extend cm ²	Retract cm ²						
RL-75N	42.6	37.1	15	6000	4.0 (40)	3.5(35)	0.01	3.0
RL-100N	77.0	71.5	20	6000	4.0 (40)	3.5(35)	0.04	4.5
RL-125N	121.2	113.1	25	6000	4.0 (40)	3.5(35)	0.06	7.0
RL-150N	175.2	160.8	30	5500	4.0 (40)	3.5(35)	0.10	9.6
RL-200N	312.5	290.4	35	5500	4.0 (40)	3.5(35)	0.29	15.5

DIMENSIONS

Model	A	B	C	D1	D2	E (h7)	F	G max.	G min.	H	J	K	L	L1	L2	M (H8)	N
RL-75N	75	15	107	90	90	65	30	45	30	57	180	M20x2.5	6-M8x16	M8x60	12	21	35
RL-100N	100	20	132	115	100	80	30	45	25	72	195	M20x2.5	6-M10x20	M8x75	12	21	35
RL-125N	125	25	160	140	130	110	35	50	25	82	205	M24x3.0	6-M12x20	M8x85	12	25	45
RL-150N	150	30	190	170	130	110	45	55	25	95	218	M30x3.5	12-M12x24	M10x100	16	32	45
RL-200N	200	35	245	220	145	120	55	70	35	115	240	M36x4.0	12-M16x 30	M10x125	21	38	60

ROTARY CYLINDERS

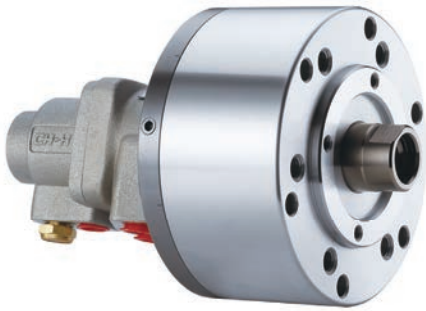

- To allow compressed air to be feed from the rear end of the distributor through the rotating union.
- Can screw it from the rear end of the cylinder when mounting.
- When used, a little oil mist should be contained.

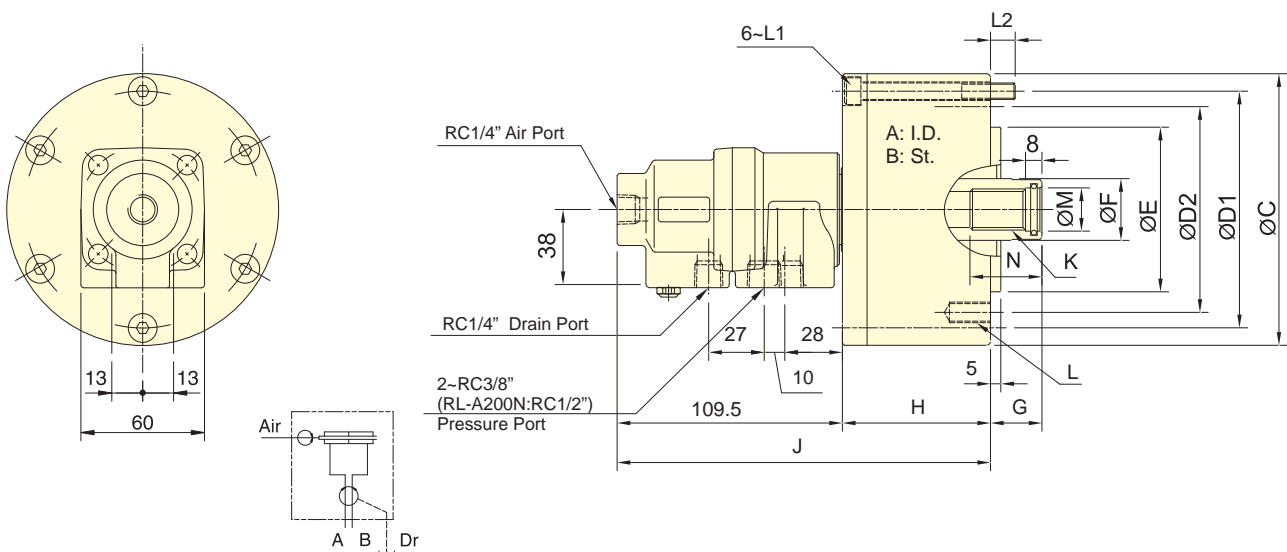

Subject to technical changes

SPECIFICATIONS

Model	Eff. piston area		Piston stroke	Max. speed	Max. pressure	Air connection Max. pressure	I	
	Extend	Retract					Moment of inertia	Weight
	cm ²	cm ²						
RL- A75N	42.6	37.1	15	6000	4.0(40)	0.8(8)	0.01	3.0
RL- A100N	77.0	71.5	20	6000	4.0(40)	0.8(8)	0.04	4.5
RL- A125N	121.2	113.1	25	6000	4.0(40)	0.8(8)	0.06	7.0
RL- A150N	175.2	160.8	30	5500	4.0(40)	0.8(8)	0.10	9.6
RL- A200N	312.5	290.4	35	5500	4.0(40)	0.8(8)	0.29	15.5

DIMENSIONS

Model	A	B	C	D1	D2	E (h7)	F	G max.	G min.	H	J	K	L	L1	L2	M (H8)	N
RL- A75N	75	15	107	90	90	65	30	45	30	57	166	M20 x2.5	6-M8x16	M8x60	12	21	35
RL- A100N	100	20	132	115	100	80	30	45	25	72	181	M20 x2.5	6-M10x20	M8x75	12	21	35
RL- A125N	125	25	160	140	130	110	35	50	25	82	191	M24x 3.0	6-M12x20	M8x85	12	25	45
RL- A150N	150	30	190	170	130	110	45	55	25	95	204	M30x3.5	12-M12x24	M10x100	16	32	45
RL- A200N	200	35	245	220	145	120	55	70	35	115	225	M36 x4.0	12-M16x30	M10x125	21	38	60

ROTARY CYLINDERS



- Medium and solid hydraulic cylinder with channel.
- Can choose an external rotary joint with either single or double paths.
- It meets the demand for coolant through spindle and airtight pressure detect function.
- Has a built-in check valve for safety.
- Stroke control via proximity switch or linear positioning system.
- The proximity switch and single or double paths rotating joint are optional.

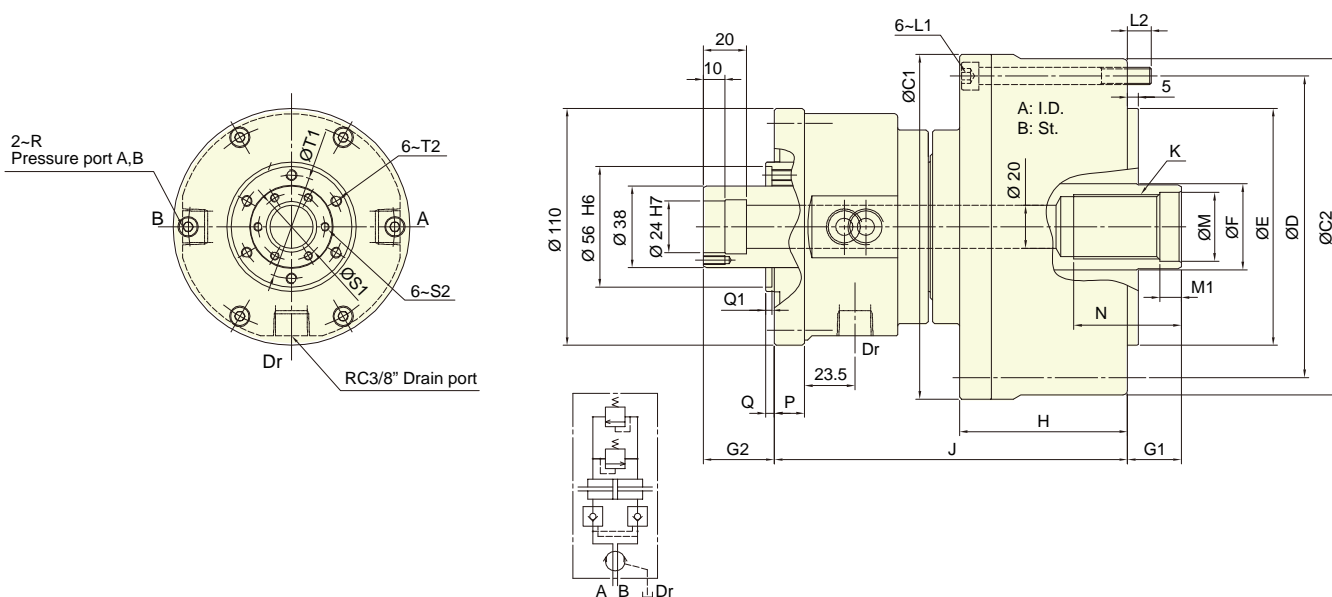

Subject to technical changes

SPECIFICATIONS

Model	Eff. piston area		Piston stroke	Max. speed	Max. pressure	I Moment of inertia	Weight
	Extend cm ²	Retract cm ²					
RC-85	43.8	48.1	20	5000	3.5(35)	0.01	6.8
RC-100	65.6	64.4	20	5000	3.5(35)	0.02	9.2
RC-125	109.8	108.5	25	5000	3.5(35)	0.03	11.1
RC-145	152.2	143.9	30	5000	3.5(35)	0.03	14.6
RC-200	279.3	273.6	35	4000	4.0(40)	0.26	35.5

DIMENSIONS

Model	A	B	C1	C2	D	E (h7)	F	G1max.	G1min.	G2max.	G2min.	H	J	K
RC-85	85	20	120	116	100	65	30	45	25	28	8	70	150	M20x1.5
RC-100	100	20	135	131	115	80	40	45	25	28	8	72	158.5	M30x1.5
RC-125	125	25	160	156	140	110	40	50	25	33	8	78	164	M30x1.5
RC-145	145	30	187	183	165	110	50	55	25	38	8	89.5	169.5	M40x1.5
RC-200	195	35	257	257	225	120	55	73	38	51.5	16.5	120	222.5	M36x4.0

Model	L1	L2	M(H8)	M1	N	P	Q	Q1	R	S1	S2	T1	T2
RC-85	6~M8x75	12.5	20.5	10	40	14	4	3	RC3/8	31	M4x10	48	M5x9
RC-100	6~M8x75	12.5	32	10	50	14	4	3	RC3/8	31	M4x10	48	M5x9
RC-125	6~M8x80	11	32	10	50	14	4	3	RC3/8	31	M4x10	48	M5x9
RC-145	6~M10x90	18	42	12	57	14	4	3	RC3/8	31	M4x10	48	M5x9
RC-200	6~M16x130	26	38	12	65	15	6.5	4	RC1/2	35	M4x10	60	M5x11

- Rotating joint and Proximity switch with bracket type.

<p>F1</p>	<p>With single path rotating joint (Fixed type)</p>	<p>F2</p>	<p>With double paths rotating joint(Fixed type)</p>
<p>M1</p>	<p>With single path rotating joint(Moving type)</p>	<p>M2</p>	<p>With double paths rotating joint(Moving type)</p>
<p>B</p>	<p>linear Sensor with bracket</p>	<p>S</p>	<p>Proximity switch with bracket</p>

* The proximity switch and rotary joint are optional.
 * Choose and attach the appropriate type.
 * Please contact AUTOGRIP for more detailed drawing.



- For short form, light weight and high speed rotary cylinder.
- Built-in safety check valves, pressure relief valves and proximity sensor.
- Can screw it from the rear end of the cylinder when mounting.
- The drain port should be independently connected to oil tank to avoid back pressure.
- Stroke Detection Type can be customized to Linear Positioning System.

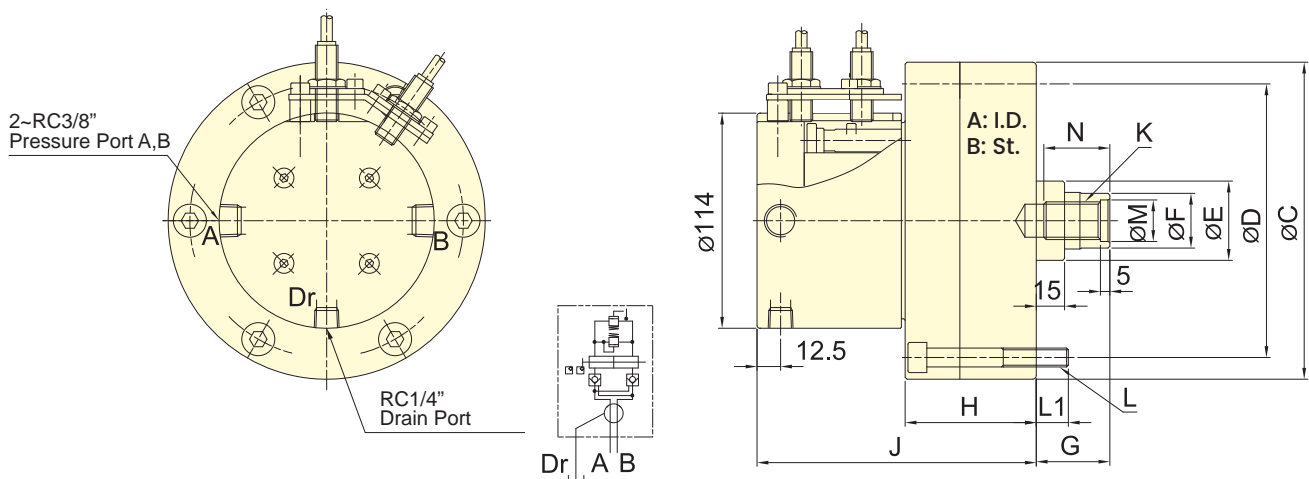

Subject to technical changes

SPECIFICATIONS

Model	Eff. piston area		Piston stroke	Max. speed	Max. pressure	I	Weight
	Extend	Retract					
	cm ²	cm ²				kg · m ²	
RE-110	92.7	87.9	20	6000	3.5(35)	0.02	6.9
RE-120	110.8	106	21	6000	4.0(40)	0.03	8.8
RE-130	130.4	123.1	30	6000	4.0(40)	0.03	9.1

DIMENSIONS

Model	A	B	C (h7)	D	E	F	G max.	G min.	H	J	K	L	L1	M (H8)	N
RE-110	110	20	145	128	42	29	60	40	66	146	M20x2.5	6~M8x70	12	22	35
RE-120	120	21	168	145	42	29	60	39	69.5	148	M20x2.5	6~M10x75	17	22	35
RE-130	130	30	168	150	50	33	60	30	79.5	158	M24x3.0	6~M10x85	17	27	40

*Proximity sensor : DC 10~30V 100mA NPN.



- For short form, light weight and high speed rotary cylinder, suitable for vertical lathe.
- Built-in safety check valves, pressure relief valves and proximity sensor.
- Can screw it from the rear end of the cylinder when mounting.
- The drain port should be independently connected to oil tank to avoid back pressure.
- Stroke Detection Type can be customized to Linear Positioning System.

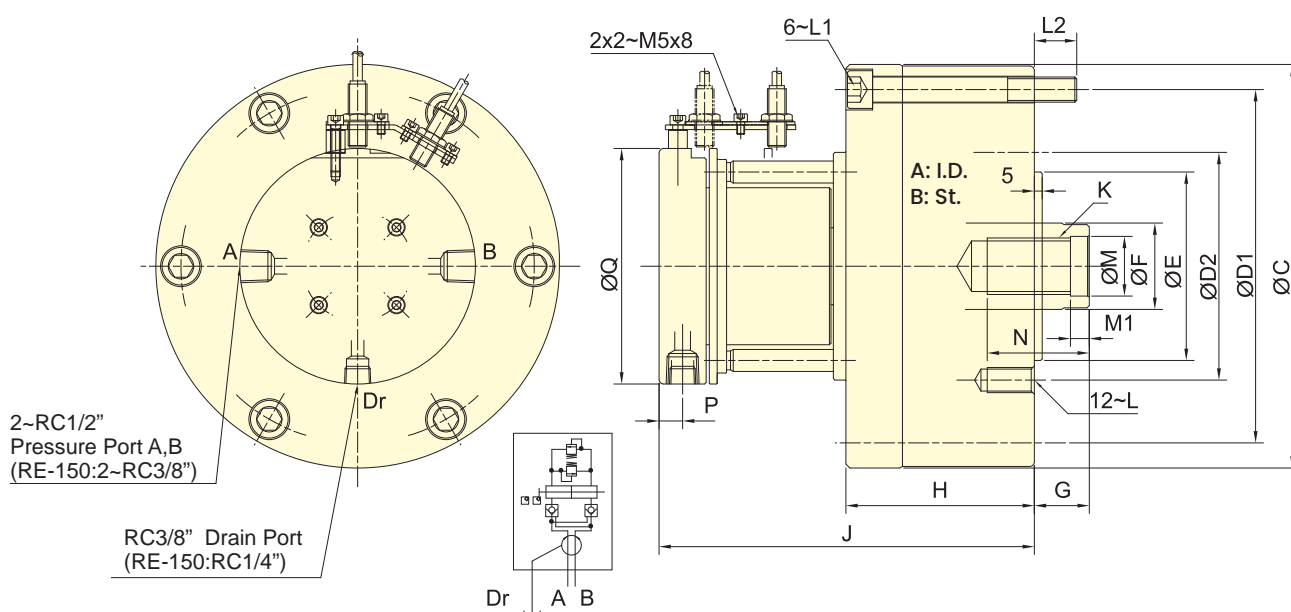

Subject to technical changes

SPECIFICATIONS

Model	Eff. piston area		Piston stroke	Max. speed	Max. pressure	I Moment of inertia	Weight
	Extend	Retract					
	cm ²	cm ²	mm	min ⁻¹ (r.p.m.)	MPa(kgf/cm ²)	kg · m ²	kg
RE-150	174.4	160.8	30	5500	4.0 (40)	0.06	14.9
RE-200K	292.4	274.9	35	4000	4.0 (40)	0.19	29.1
RE-200L	292.4	265.4	50	4000	5.0 (50)	0.21	30.4
RE-250	465.2	438.2	60	2000	5.0 (50)	0.43	47.2

DIMENSIONS

Model	A	B	C	D1	D2	E (h7)	F	G max.	G min.	H	J	K	L	L1	L2	M (H8)	M1	N	P	Q
RE-150	150	30	205	180	130	110	45	60	30	99	177.5	M30x3.5	M12x24	M12x105	18.5	32	10	50	12.5	114
RE-200K	195	35	257	225	145	120	55	73	38	120	239	M36x4.0	M16x30	M16x130	27	38	12	65	15	150
RE-200L	195	50	257	225	170	125	65	80	30	135	254	M42x3.0	M16x30	M16x145	27	45	12	65	15	150
RE-250	245	60	307	275	220	160	65	85	25	165	280	M42x3.0	M20x35	M16x175	28	45	12	65	15	150

*Proximity sensor : DC 10-30V 100mA NPN.



- For short form, light weight and high speed rotary cylinder. To allow compressed air to be feed from the rear end of the distributor through the rotating union.
- Built-in safety check valves, pressure relief valves and proximity sensor.
- Can screw it from the rear end of the cylinder when mounting.
- The drain port should be independently connected to oil tank to avoid back pressure.
- When used, a little oil mist should be contained.
- Stroke Detection Type can be customized to Linear Positioning System.

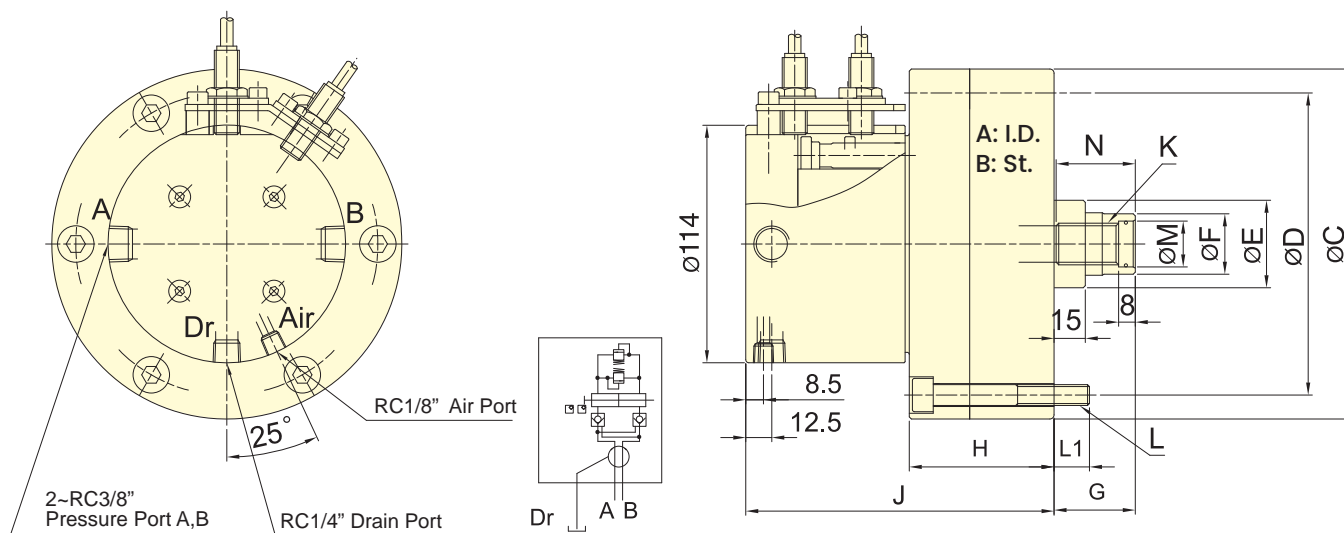

Subject to technical changes

SPECIFICATIONS

Model	Eff. piston area		Piston stroke	Max. speed	Max. pressure	Air connection Max. pressure	I Moment of inertia	Weight
	Extend	Retract						
	cm ²	cm ²	mm	min ⁻¹ (r.p.m.)	MPa(kgf/cm ²)	MPa (kgf/cm ²)	kg · m ²	kg
RE-A110	91.2	87.9	20	6000	4.0(40)	0.8(8)	0.02	6.9
RE-A120	109.3	106	21	6000	4.0(40)	0.8(8)	0.02	8.8
RE-A130	128.9	123.1	30	6000	4.0(40)	0.8(8)	0.03	9.1

DIMENSIONS

Model	A	B	C (h7)	D	E	F	G max.	G min.	H	J	K	L	L1	M (H8)	N
RE-A110	110	20	145	128	42	29	60	40	66	146	M20x2.5	6~M8x70	12	22	38
RE-A120	120	21	168	145	42	29	60	39	69.5	148	M20x2.5	6~M10x75	17	22	38
RE-A130	130	30	168	150	50	33	60	30	79.5	158	M24x3.0	6~M10x85	17	27	43

*Proximity sensor : DC 10-30V 100mA NPN.



- For short form, light weight and high speed rotary cylinder. To allow compressed air to be feed from the rear end of the distributor through the rotating union.
- Built-in safety check valves, pressure relief valves and proximity sensor.
- Can screw it from the rear end of the cylinder when mounting.
- The drain port should be independently connected to oil tank to avoid back pressure.
- When used, a little oil mist should be contained.
- Stroke Detection Type can be customized to Linear Positioning System.

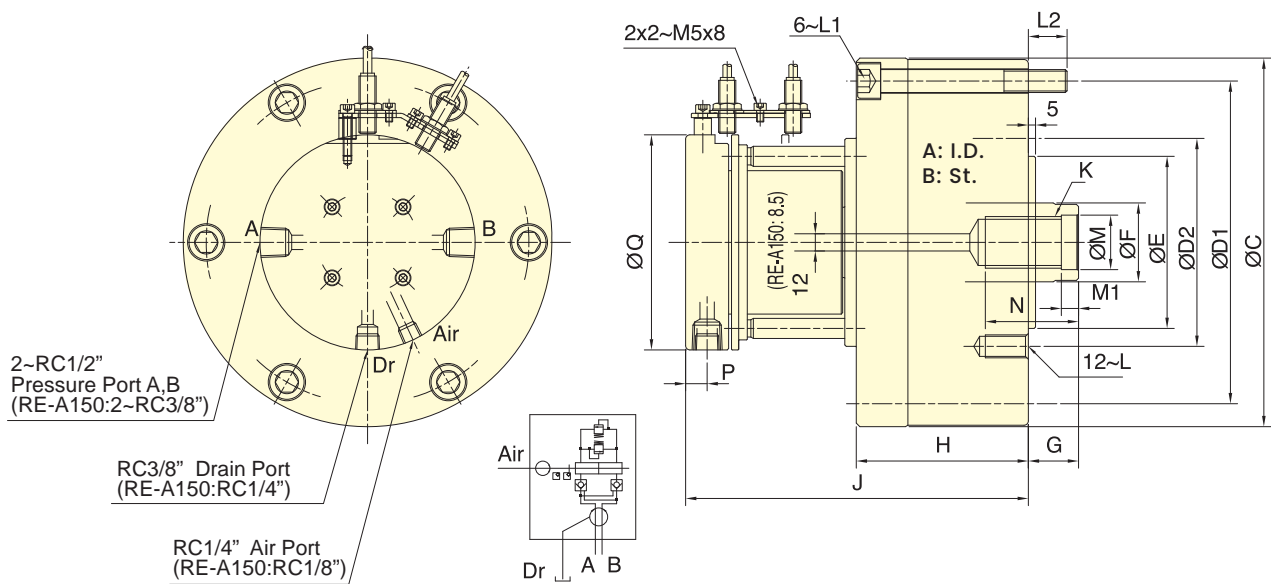

Subject to technical changes

SPECIFICATIONS

Model	Eff. piston area		Piston stroke	Max. speed	Max. pressure	Air connection Max. pressure	I		Weight
	Extend	Retract					Moment of inertia		
	cm ²	cm ²	mm	min ⁻¹ (r.p.m.)	MPa(kgf/cm ²)	MPa (kgf/cm ²)	kg · m ²		kg
RE-A150	174.4	160.8	30	5500	4.0(40)	0.8(8)	0.06		14.9
RE-A200K	292.4	274.9	35	4000	4.0(40)	0.8(8)	0.19		29.1
RE-A200L	292.4	265.4	50	4000	5.0(50)	0.8(8)	0.21		30.4
RE-A250	465.2	438.2	60	2000	5.0(50)	0.8(8)	0.43		47.2

DIMENSIONS

Model	A	B	C	D1	D2	E (h7)	F	G max.	G min.	H	J	K	L	L1	L2	M (H8)	M1	N	P	Q
RE-A150	150	30	205	180	130	110	45	60	30	99	177.5	M30x3.5	M12x24	M12x105	18.5	32	10	50	12.5	114
RE-A200K	195	35	257	225	145	120	55	73	38	120	239	M36x4.0	M16x30	M16x130	27	38	12	65	15	150
RE-A200L	195	50	257	225	170	125	65	80	30	135	254	M42x3.0	M16x30	M16x145	27	45	12	65	15	150
RE-A250	245	60	307	275	220	160	65	85	25	165	280	M42x3.0	M20x35	M16x175	28	45	12	65	15	150

*Proximity sensor : DC 10~30V 100mA NPN.



- For short form, light weight and high speed rotary cylinder. To allow coolant to be feed from the rear end of the distributor through the rotating union.
- Built-in safety check valves, pressure relief valves and proximity sensor.
- Can screw it from the rear end of the cylinder when mounting.
- The drain port should be independently connected to oil tank to avoid back pressure.
- The rotary cylinder should not run without liquid through coolant port.
- Stroke Detection Type can be customized to Linear Positioning System.

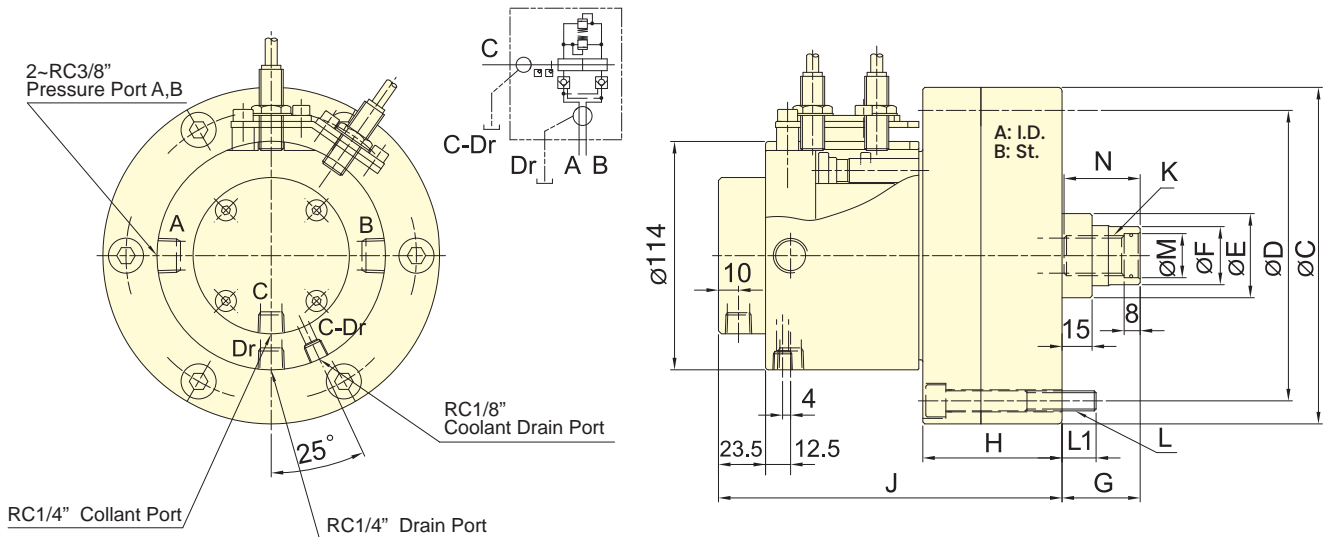

Subject to technical changes

SPECIFICATIONS

Model	Eff. piston area		Piston stroke	Max. speed	Max. pressure	Coolant connection Max. pressure	I Moment of inertia	Weight
	Extend	Retract						
	cm ²	cm ²						
RE-L110	92.7	87.9	20	6000	4.0(40)	1.5(15)	0.02	7.2
RE-L120	109.3	106	21	6000	4.0(40)	1.5(15)	0.03	9.1
RE-L130	128.9	123.1	30	6000	4.0(40)	1.5(15)	0.03	9.5

DIMENSIONS

Model	A	B	C (h7)	D	E	F	G max.	G min.	H	J	K	L	L1	M (H8)	N
RE-L110	110	20	145	128	42	29	60	40	66	169.5	M20x2.5	6~M8x70	12	22	38
RE-L120	120	21	168	145	42	29	60	39	69.5	171.5	M20x2.5	6~M10x75	17	22	38
RE-L130	130	30	168	150	50	33	60	30	79.5	181.5	M24x3.0	6~M10x85	17	27	43

*Proximity sensor : DC 10-30V 100mA NPN.



- For short form, light weight and high speed rotary cylinder. To allow coolant to be feed from the rear end of the distributor through the rotating union, suitable for vertical lathe.
- Built-in safety check valves, pressure relief valves and proximity sensor.
- Can screw it from the rear end of the cylinder when mounting.
- The drain port should be independently connected to oil tank to avoid back pressure.
- The rotary cylinder should not run without liquid through coolant port.
- Stroke Detection Type can be customized to Linear Positioning System.

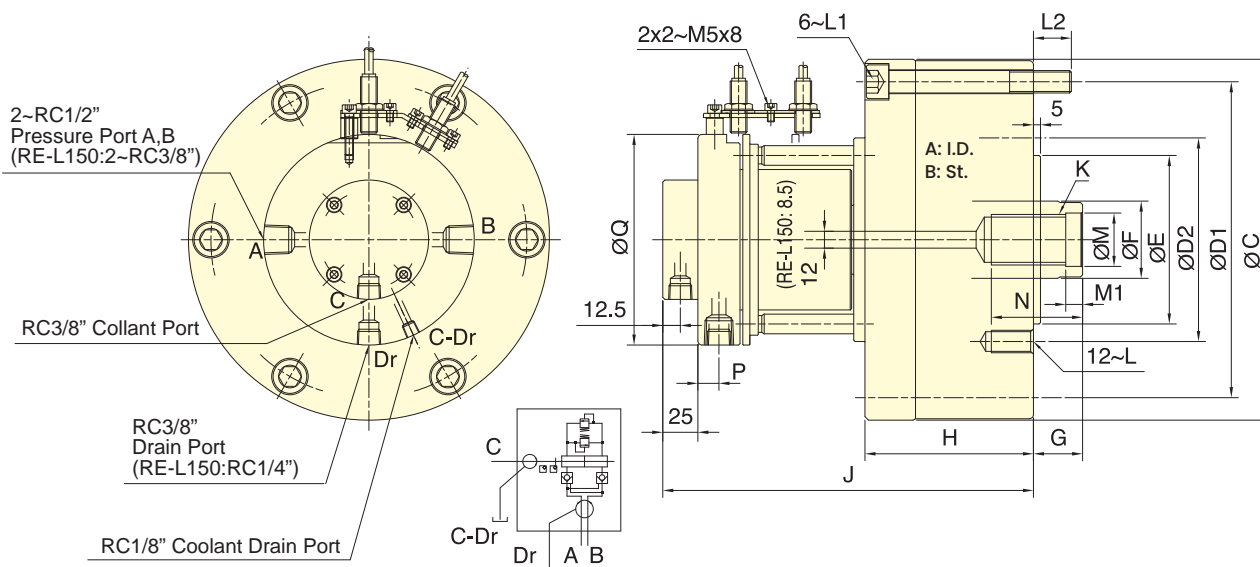

Subject to technical changes

SPECIFICATIONS

Model	Eff. piston area		Piston stroke mm	Max. speed min ⁻¹ (r.p.m.)	Max. pressure MPa(kgf/cm ²)	Coolant connection Max. pressure MPa (kgf/cm ²)	I		Weight kg
	Extend	Retract					Moment of inertia	kg · m ²	
	cm ²	cm ²							
RE-L150	174.4	160.8	30	5500	4.0(40)	1.5(15)	0.06	15.2	
RE-L200K	292.4	274.9	35	4000	4.0(40)	1.5(15)	0.19	29.4	
RE-L200L	292.4	265.4	50	4000	5.0(50)	1.5(15)	0.21	30.7	
RE-L250	465.2	438.2	60	2000	5.0(50)	1.5(15)	0.43	47.5	

DIMENSIONS

Model	A	B	C	D1	D2	E (h7)	F	G max.	G min.	H	J	K	L	L1	L2	M (H8)	M1	N	P	Q
RE-L150	150	30	205	180	130	110	45	60	30	99	201	M30x3.5	M12x24	M12x105	18.5	32	10	50	12.5	114
RE-L200K	195	35	257	225	145	120	55	73	38	120	264	M36x4.0	M16x30	M16x130	27	38	12	65	15	150
RE-L200L	195	50	257	225	170	125	65	80	30	135	279	M42x3.0	M16x30	M16x145	27	45	12	65	15	150
RE-L250	245	60	307	275	220	160	65	85	25	165	305	M42x3.0	M20x35	M16x175	28	45	12	65	15	150

*Proximity sensor : DC 10-30V 100mA NPN.



- Rotary valve is used for clamping cylinder on rotary table.
- Through unique design, it can make the rotary housing be rotated light force and is free from oil leaking.
- I Type is a single circuit which controls the clamping.
- II Type is a double circuit which separately controls the clamping.
- The drain port of RV type should be independently connected to oil tank to avoid back pressure.

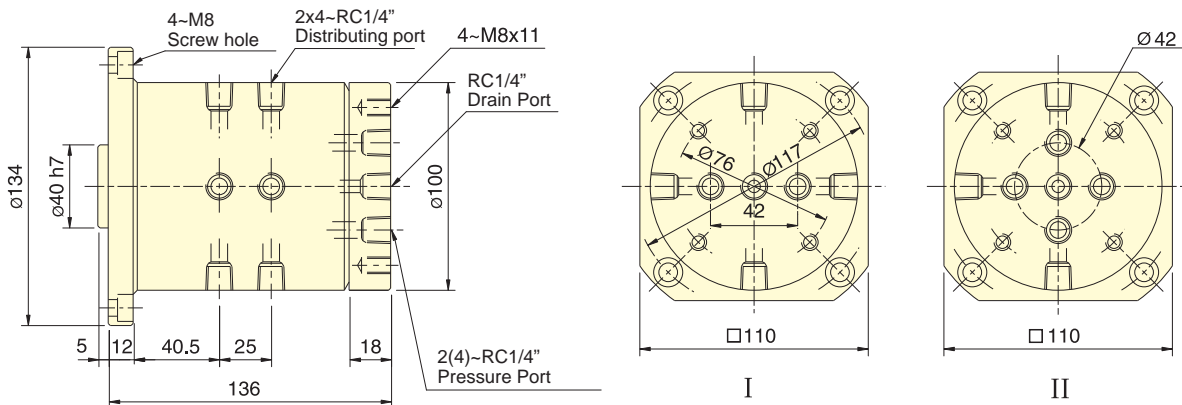

Subject to technical changes

SPECIFICATIONS

Model	Distributing	Max. pressure	Weight
		MPa(kgf/cm ²)	kg
RV-31H	4 (by order)	4.0 (40)	7.4

Note:RV can be custom-made.

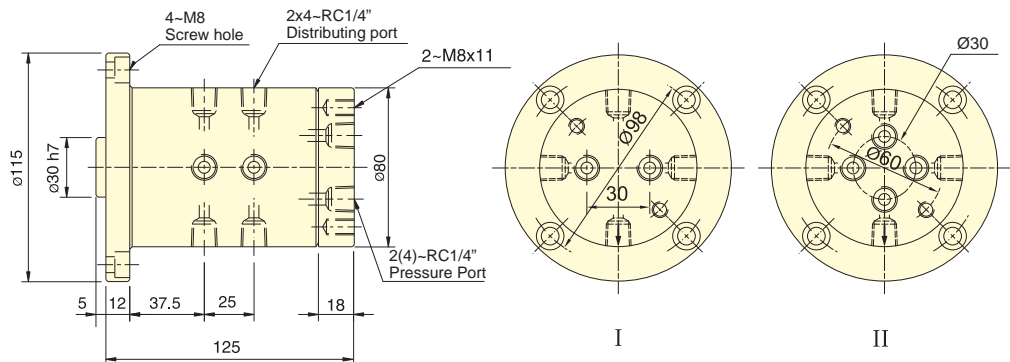

Subject to technical changes

SPECIFICATIONS

Model	Distributing	Max. pressure	Weight
		MPa(kgf/cm ²)	kg
RV-A31H	4 (by order)	0.8 (8)	4.8

Note:RV-A can be custom-made.



- Coolant joint for high speed, high pressure. Usable for oil and water-soluble coolant.
- Seal bushing inside is made of cemented carbide and ceramics, which provide higher wear-resistance.
- The joint should not run without liquid through coolant port.

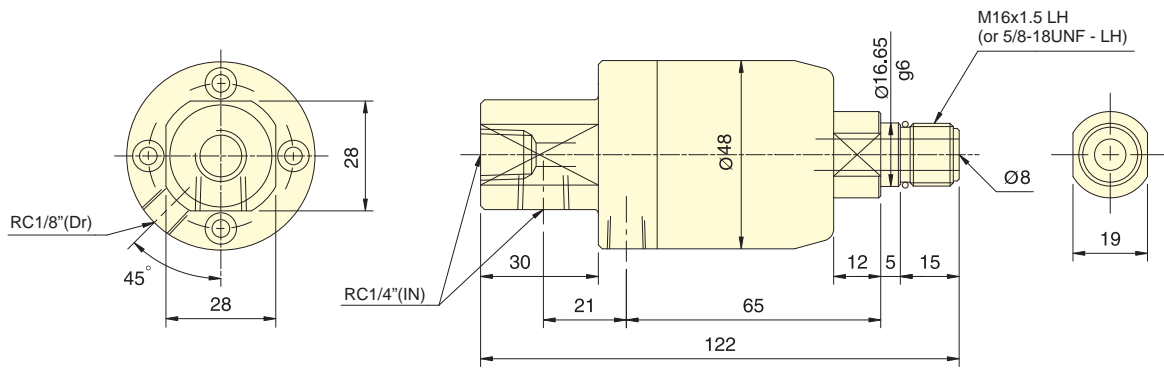

Subject to technical changes

SPECIFICATIONS

Model	PV Limit value MPa · r/m	Max. pressure MPa(kgf/cm ²)	Delivery amount (at 50 kgf/cm ²)	Max. speed (r.p.m.)	Weight (kg)
RJ-80	14400	6.0 (60)	28 l/min	8000	0.5



- Short form, light weight coolant rotating joint.
- Coolant joint for high speed, high pressure. Usable for oil and water-soluble coolant.
- Seal bushing inside is made of cemented carbide and ceramics, which provide higher wear-resistance.
- The seal will depart automatically if no liquid passes during operation, and will not be damaged due to dry touching.
- Min. pressure is 4kgf/cm².

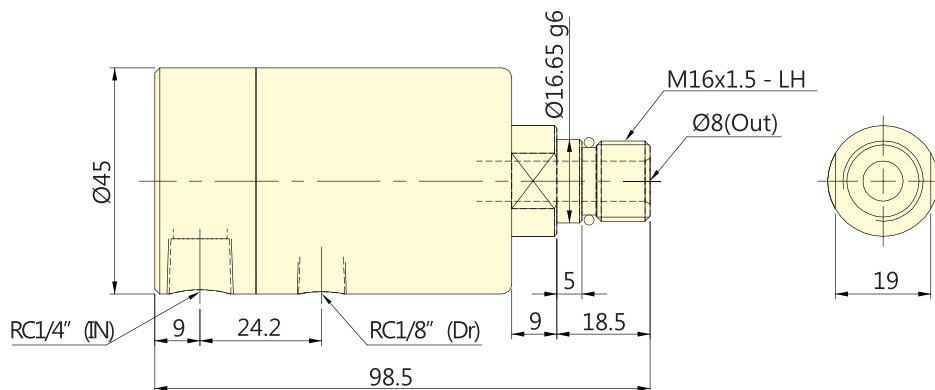

Subject to technical changes

SPECIFICATIONS

Model	PV Limit value MPa · r/m	Max. pressure MPa(kgf/cm ²)	Delivery amount (at 50 kgf/cm ²)	Max. speed (r.p.m.)	Min. pressure MPa(kgf/cm ²)	Weight (kg)
RJ-92	17500	7.0(70)	28 l/min	10000	0.4 (4)	0.46

Standard Soft Jaw for 2D/3D chuck

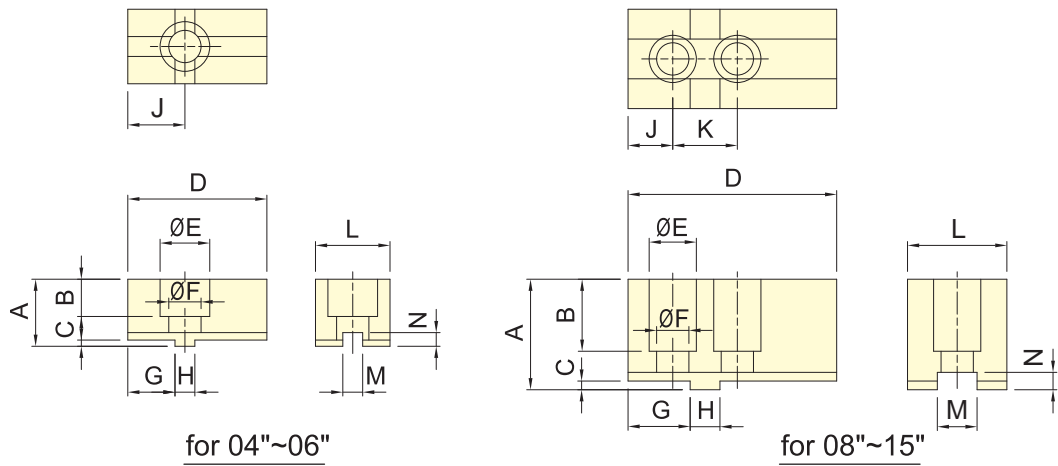

Subject to technical changes

DIMENSIONS

इ पणडठ	क	ख	ग	घ	ङ	च	छ	ज	ञ	ट	ठ	ड	ढ
3D-04	22	13	2.5	52	17.5	11	19	8	19	-	25	8	5.5
3D-05	27	15	2.5	56	20	13	23	8	23	-	30	8	5.5
3D-06	34	21	3	70	23	15.5	27	10	27	-	35	10	6
3D-08	44.5	29	3.5	84	19	13	31	12	18	26	40	16	7
3D-10	49.5	32	3.5	100	22	15	38	15	22	32	50	18	7
3D-12	54.5	36	3.5	120	26	18	42	17	24	36	60	20	7
3D-15	65	40	5	165	26	18	60	20	40	40	70	24	10

Standard Soft Jaw for 3E chuck

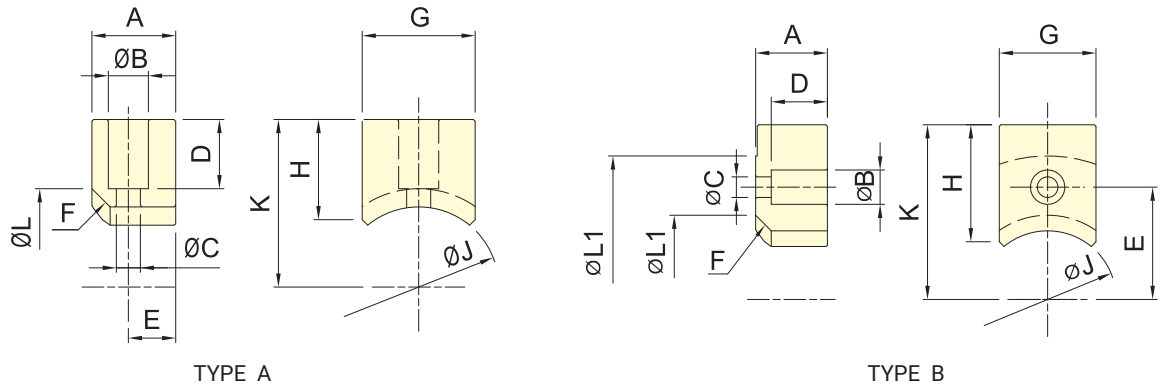

Subject to technical changes

DIMENSIONS

इ पणडठ		क	ख	ग	घ	ङ	च	छ	ज	ञ	ट	ठ	डॉ
3E-05	A Type	20	11	6.6	16.5	10	C5	25	22	29	34.5	39	-
	B Type	20	11	6.6	15	25.5	C5	25	30	29	42.5	39	69
3E-06	A Type	23	11	7	19	13	C5	31	27.5	44	46	54	-
	B Type	23	11	6.6	18	36	C5	31	37.5	44	56	54	92
3E-08	A Type	30	14	9	25	15	C6	35	36	50	56	62	-
	B Type	30	14	9	24	41	C6	35	56	50	76	62	112
3E-10	A Type	35	17.5	11	26.5	17.5	C5	40	40	60	64.5	70	-
	B Type	35	17.5	11	26	47.5	C5	40	71.5	60	96	70	129

Standard Soft Jaw for 3R chuck

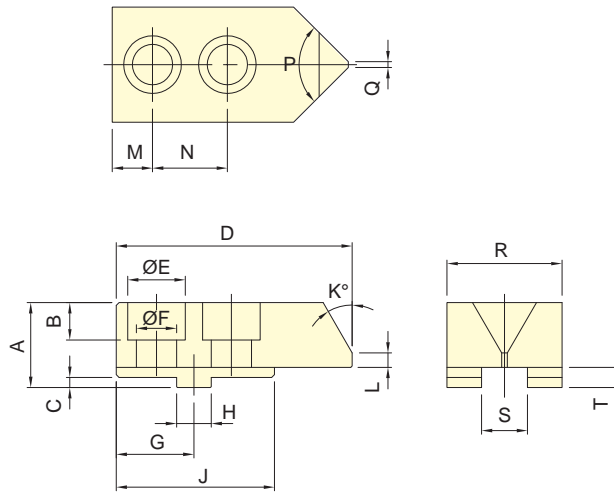

Subject to technical changes

DIMENSIONS

উপঘড়ক	ক	খ	গ	ঘ	ঙ	চ	ছ	জ	ঝ	ট	ঠ	ড	ঢ	ত	থ	দ	ধ	ন
3R-08	29.5	13	3.5	82	20	14	27	12	55	30	5	14	26	90	2	40	16	7
3R-10	30.5	15	3.5	102	23	16	37	15	65	30	7	21	32	90	2	40	18	7

Standard Soft Jaw for 3W chuck

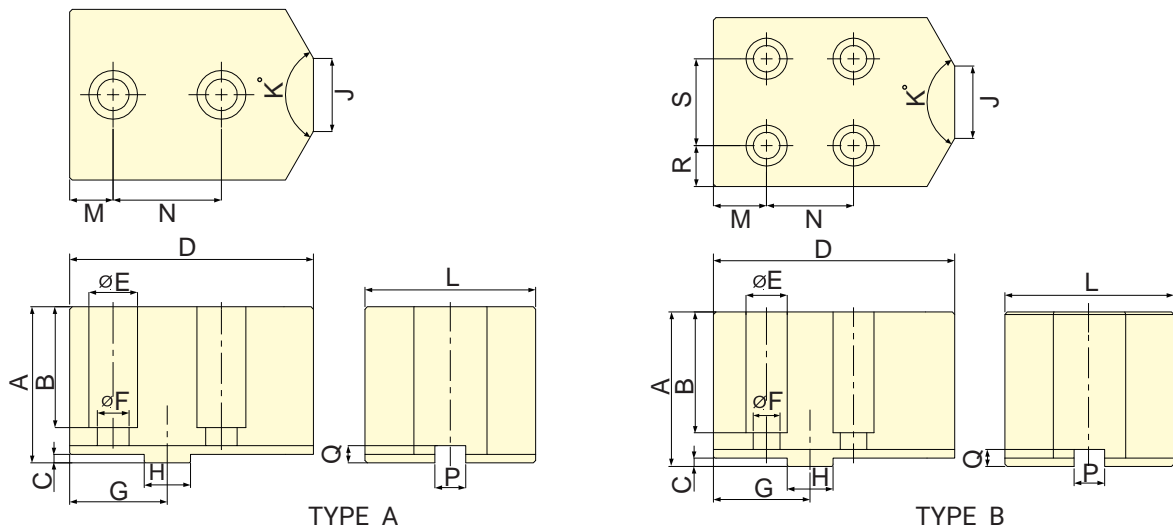

Subject to technical changes

DIMENSIONS

উপঘড়ক		ক	খ	গ	ঘ	ঙ	চ	ছ	জ	ঝ	ট	ঠ	ড	ঢ	ত	থ	দ	ধ
3W-08	A Type	60	44	3.5	80	20	13	35	12.68	30	120	57	16	38	7.94	7	-	-
	B Type	60	48	3.5	80	17	11	35	12.68	30	120	57	19	32	7.94	7	12.5	32
3W-10	A Type	64	49.5	3.5	100	20	13	40	19.03	30	120	70	17.8	44.4	12.7	7	-	-
	B Type	64	50	3.5	100	17	11	40	19.03	30	120	70	22	36	12.7	7	17	36
3W-12	A Type	64	49.5	3.5	100	20	13	40	19.03	30	120	70	17.8	44.4	12.7	7	-	-
	B Type	64	50	3.5	100	17	11	40	19.03	30	120	70	22	36	12.7	7	17	36

*3W series Carbide gripper is optional. * The type of the gripper is selected according to the work-piece conditions.

Standard Soft Jaw for 3MF chuck

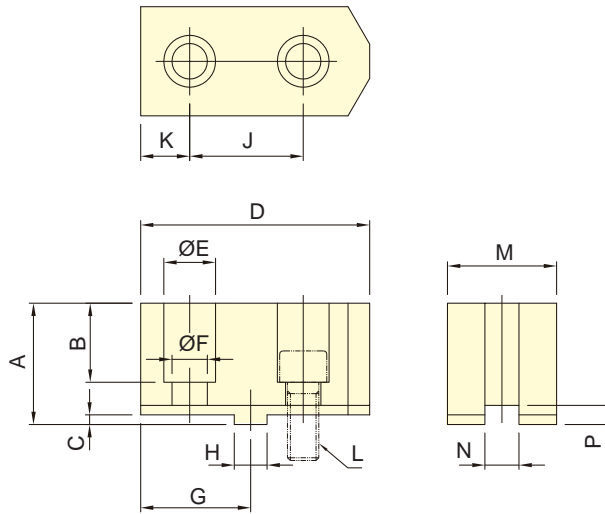

Subject to technical changes

DIMENSIONS

উপঘড়ন	ক	খ	গ	ঘ	ঙ	চ	ছ	জ	ঝ	ট	ঠ	ড	ঢ	ত	3 অর্ড ব ক্য়ান্স স্ফার
3MF-20	70	48	6	160	25	17	80	19.03	76.2	41.9	M16	50	12.7	11.5	10.4

Standard Soft Jaw for AP chuck

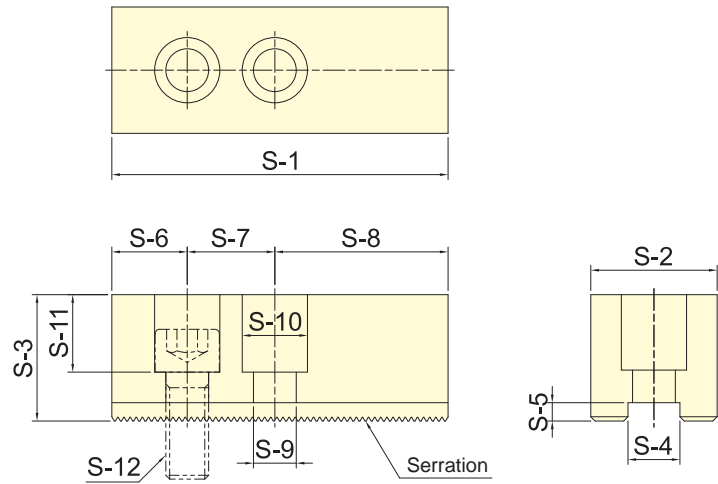
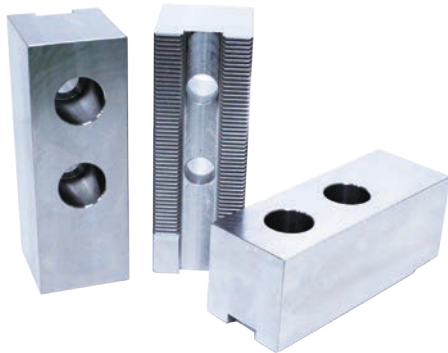

Subject to technical changes

DIMENSIONS

উপঘড়ন	ধআঁ	ধআ	ধআ	ধআ	ধআ	ধআ	ধআ	ধআ	ধআ	ধআঁ	ধআঁ	ধআঁ	ধব্বহ্বল্ল ক্তরুঙ্গল	উ হফস্ফল্লা গল্লক্শক	3 অর্ড ব ক্য়ান্স স্ফার
SJ-145	165	62	62	25.5	9	37	43	85	21	32	38	M20	3.0 × 60°	AP-145, AP-185	12.2
SJ-185	165	62	62	25.5	9	37	43	85	21	32	38	M20	3.0 × 60°	AP-145, AP-185	12.2
SJ-230	180	64	70	25.5	9	40	60	80	21	32	45	M20	3.0 × 60°	AP-230, AP-275	16.1
SJ-275	180	64	70	25.5	9	40	60	80	21	32	45	M20	3.0 × 60°	AP-230, AP-275	16.1
SJ-320	210	75	80	30	9	40	60	110	26	38	55	M24	3.0 × 60°	AP-320, AP-375	24.7

STANDARD HARDEN JAW FOR AP CHUCK

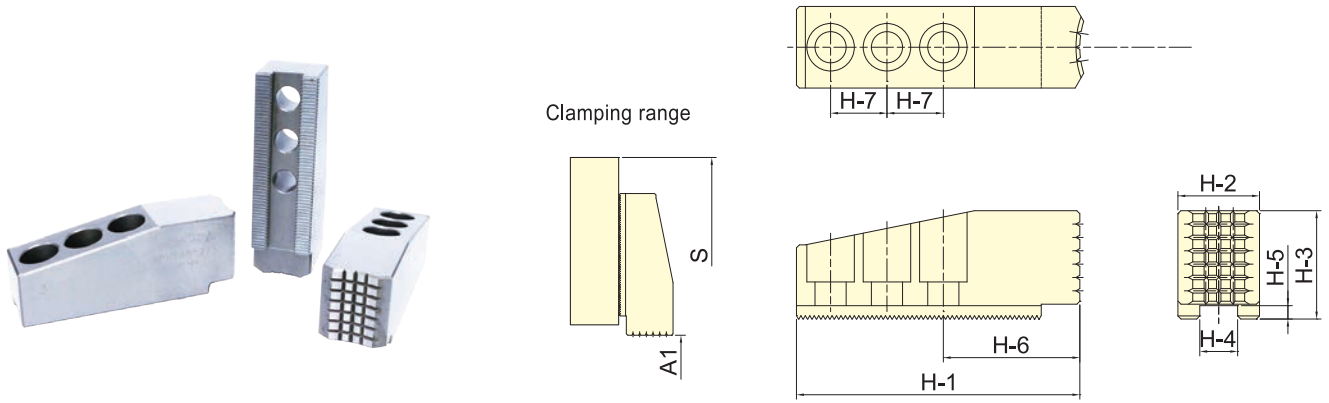

Subject to technical changes

DIMENSIONS

ड गज्जह	जओँ	जओ	जओ	जओ	जओ	जओ	जओ	कओँ	ध	धरव्हहृरुतइदल	ड हव्हहृरुगज्जहृ	3 व्हहृ व क्कलरु क्कलरु
HJ-145	191	55	73	25.5	9	92	38	28-120	420	3.0 × 60°	AP-145	12.5
HJ-145	191	55	73	25.5	9	92	38	28-155	460	3.0 × 60°	AP-185	12.5
HJ-145	191	55	73	25.5	9	92	38	60-235	535	3.0 × 60°	AP-230	12.5
HJ-145	191	55	73	25.5	9	92	38	105-280	580	3.0 × 60°	AP-275	12.5
HJ-320	243	75	82	30	9	110	50	100-295	658	3.0 × 60°	AP-320	24.6
HJ-320	243	75	82	30	9	110	50	175-375	738	3.0 × 60°	AP-375	24.6

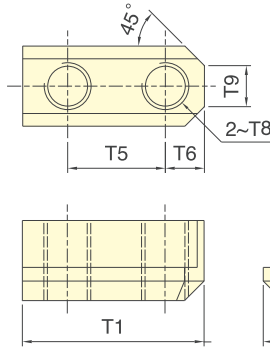

TN1

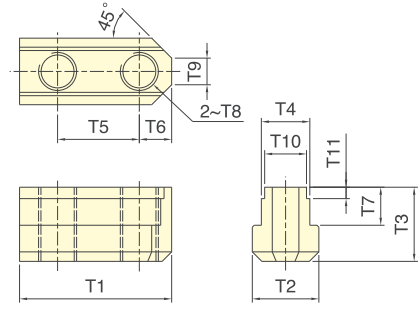

TN2

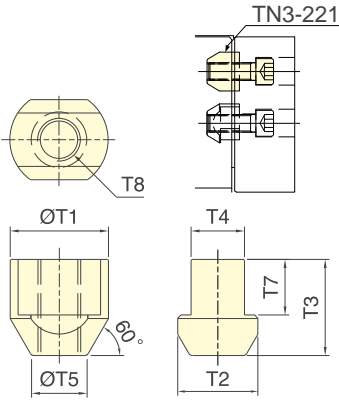

TN3

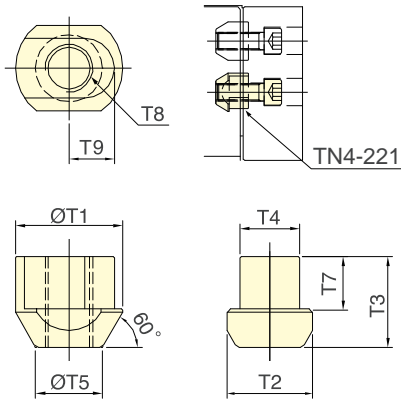

TN4

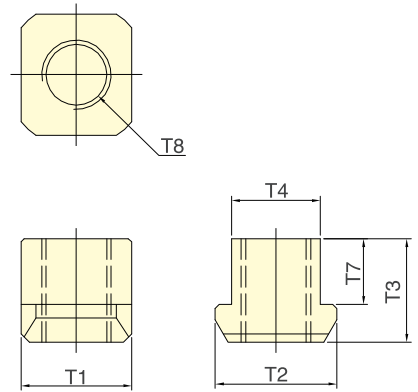

TN5

Subject to technical changes

DIMENSIONS

ड गज्ज्	नऑ	न	न३	न४	न६	नू	न७	न८	नू	नऑ	नऑ	ड हय्दुगज्ज्	३ तक्षुव लुगुगु
													लुगु
TN1-04	26	14	15	10	14	6	9.5	M8	5	-	-	H-204, H-205, P-04, P-05, L-205, M-05, SP-304	0.06
TN1-06	36	17	18.5	12	20	8	11	M10	6	-	-	H-206, P-06, L-206, 1L-06, M-06, 3N-06, AP-52, RAP-306, SP-306	0.15
TN1-08	46.5	20	20.5	14	25	10.5	12	M12	10	-	-	H-208, P-08, L-208, 1L-08, M-08, 3N-08, 4T-08, AP-66, RAP-308, SP-308	0.27
TN1-10	51	22	21.5	16	30	11	13	M12	11	-	-	H-10, H-210, P-10, L-210, 1L-10, M-10, 3N-10, 4T-10, AP-86, RAP-310, SP-310	0.36
* TN1-12	55.5	29.5	28	21	30	12	16.7	M16	13	-	-	H-12, P-12, L-12, M-12	0.63
TN2-12	55.5	29.5	28	21	30	12	16.7	M14	13	18	4.5	H-12, P-12, L-12, M-12	0.63
* TN1-15	80	35	39	25.5	43	17	20	M20	14	-	-	H-15, H-18, H-18B, P-15, P-215, P-218, L-15, M-215, M-218, V-15, V-18	1.53
TN2-15	80	35	39	25.5	43	17	20	M20	14	22	6	H-15, H-18, H-18B, P-15, P-215, P-218, L-15, M-215, M-218, V-15, V-18	1.5
* TN1-212	56	29.5	23.5	21	30	12	12	M16	10	-	-	H-212, L-212, V-12, 4T-15, AP-115	0.63
TN2-212	56	29.5	23.5	21	30	12	12	M14	10	18	4	H-212, L-212, V-12, 4T-15, AP-115	0.63
* TN1-215	80	35	34	25.5	43	17	19	M20	14	-	-	H15, H-215, L-215, SP-316	1.32
TN2-215	80	35	34	25.5	43	17	19	M20	14	22	6	H15, H-215, L-215, SP-316	1.29
TN3-21	46	37.5	45	25	26	-	26	M20	-	-	-	P-221, P-224, M-221, M-224, V-21, V-24, V-32,	1.84
TN3-221	45	36	38	25	28	-	22	M20	-	-	-	H-221, H-224, H-232, SP-320, SP-324	0.69
TN4-221	45	36	38	25	28	-	22	M20	19	-	-	H-221, H-224, H-232, SP-320, SP-324	0.63
TN5-185	32	35	30	25.5	-	-	19	M20	-	-	-	AP-145, AP-185, AP-230, AP-275	0.15
TN5-320	36	42	39	30	-	-	24	M24	-	-	-	AP-320, AP-375	0.24

* 12" Chucks are originally equipped with TN1-12 & TN1-212.

* 15" Chucks are originally equipped with TN1-15 & TN1-215.

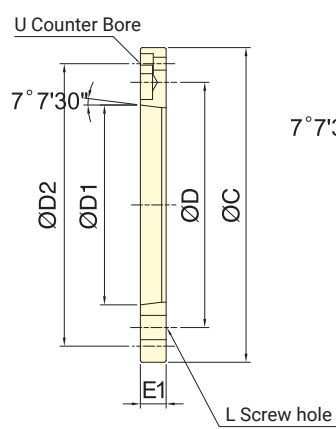

FL1

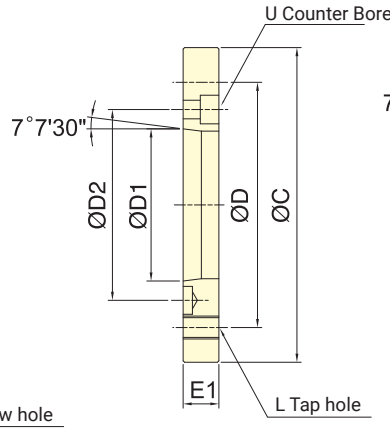

FL2

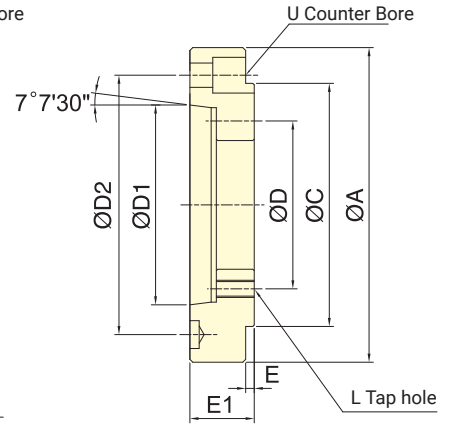

FL3

Subject to technical changes

DIMENSIONS

डॉ. क्र. (Doc. No.)	क (K)	ग (G)	घ (Gh)	घऑ (GhA)	घा (Gha)	ङ (D)	डऑ (DA)	ठ (T)	प (P)	दस्तावेज (Drawing)	वक्रांक (Modulus)
FL3-04A24	110	85	70.6	63.513	82.6	8	28	M10	M10	3H-204, 2H-204	1.12
FL3-04A25	140	85	70.6	82.563	104.8	5.5	32	M10	M10	3H-204, 2H-204	2.28
FL1-05A24	-	110	82.6	63.513	96	-	15	M10	M6	3H-205, 2H-205, 3L-05, 2L-05, 3J-05, 2J-05	0.65
FL3-05A25	135	110	82.6	82.563	104.8	6	30	M10	M10	3H-205, 2H-205, 3L-05, 2L-05	1.99
FL1-06A25	-	140	104.8	82.563	116	-	15	M10	M6	2H-206, 4H-206, 3H-206, 3P-06, 2P-06, 3M-06, 2M-06, 3E-06, 3D-06, 2D-06, 3N-06, 3J-06, 2J-06	0.96
							*18				
FL3-06A26	165	140	104.8	106.375	133.4	6	35	M10	M12	2H-206, 4H-206, 3H-206, 3L-206, 2L-206, 3P-06, 2P-06, 3M-06, 2M-06, 3E-06, 3D-06, 2D-06, 3N-06, 3J-06, 2J-06	3.12
FL2-08A25	-	170	133.4	82.563	104.8	-	23	M12	M10	3H-208, 2H-208, 4H-208, 3P-08, 2P-08, 3M-08, 2M-08, 4T-08, 3E-08, 3D-08, 2D-08, 3N-08, 3J-08, 2J-08, 3R-08, 3W-08, 3Q-08	2.7
FL1-08A26	-	170	133.4	106.375	150	-	17	M12	M6	2H-208, 4H-208, 3H-208, 3P-08, 2P-08, 3M-08, 2M-08, 4T-08, 3E-08, 3D-08, 2D-08, 3N-08, 3J-08, 2J-08, 3R-08, 3W-08, 3Q-08	1.55
							*23				
FL2-10A26	-	220	171.4	106.375	133.4	-	25	M16	M12	4H-10, 3P-10, 2P-10, 3M-10, 2M-10, 3H-12, 2H-12, 4H-12, 3L-212, 2L-12, 3P-12, 2P-12, 3M-12, 2M-12, 4T-10, 4T-12, 3E-10, 3D-10, 2D-10, 3N-10, 3J-10, 2J-10, 3R-10, 3Q-10, 3W-10, 3W-12	5.02
FL1-10A28	-	220	171.4	139.719	190	-	18	M16	M8	2H-210, 4H-10, 3H-210, 3L-210, 2L-210, 3P-10, 2P-10, 3M-10, 2M-10, 3H-12, 2H-12, 4H-12, 3L-212, 2L-12, 3P-12, 2P-12, 3M-12, 2M-12, 4T-10, 4T-12, 3E-10, 3D-10, 2D-10, 3N-10, 3J-10, 2J-10, 3R-10, 3Q-10, 3Q-12, 3W-10, 3W-12	2.73
FL2-15A28	-	300	235	139.719	171.4	-	33	M20	M16	3H-15, 3H-212, 2H-15, 4H-15, 3L-15, 2L-15, 3P-215, 2P-15, 3M-15, 2M-15, 4T-15, 3H-18, 4H-18, 3P-218	12.52
FL1-15A211	-	300	235	196.869	260	-	22	M20	M10	3H-15, 3H-212, 2H-15, 4H-15, 3L-15, 2L-15, 3P-215, 2P-15, 3M-15, 2M-15, 4T-15, 3H-18, 4H-18, 3P-218	6.03
FL2-21A28	-	380	330.2	139.719	171.4	-	33	M24	M16	3H-215, 3P-221, 3P-224	22.05
FL2-21A211	-	380	330.2	196.869	235	-	40	M24	M20	3H-215	16.28
							*27				
FL1-21A215	-	380	330.2	285.775	330.2	-	27	M24	M12	3H-215, 3H-18B, 3H-221, 3P-221, 3P-224	8.6
FL2-40A215	-	520	463.6	285.775	330.2	-	40	M24	M24	3H-224	43.26
FL1-40A220	-	520	463.6	412.775	463.6	-	27	M24	M12	3H-224, 3H-232	13.55

Models with "*" mark are produced only by order.

CT-SB/CT-SBS COOLANT COLLECTOR WITH STROKE CONTROL



- The proximity switch and linear Sensor are optional.
- Drain port Ø40 and Ø60 are optional product.
- Drain port Ø60 only use to CT-S08B,CT-S10B.

■ The proximity switch is optional.

तट्टकककककक	धट्टडडडडडड डडडडड	णडडडडडडडड
DC 10/30V	100mA	NPN

■ Terminal Connections

+फ	णतऑ	णफ
BROWN	BLACK	BLUE

■ linear Sensor installation drawing

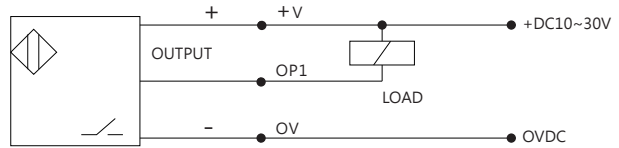
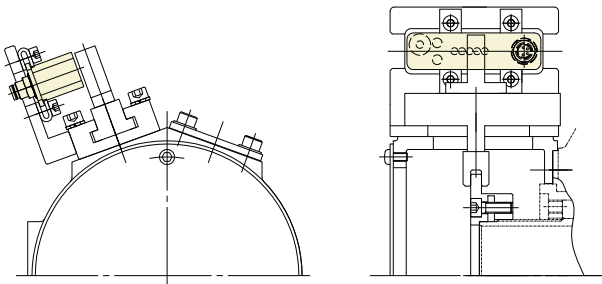

CT-SB

CT-SBS

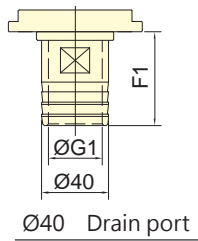

Ø40 Drain port

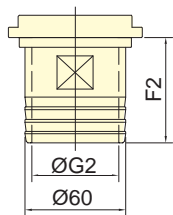

Ø60 Drain port
(Only use to CT-S08B/CT-S10B)

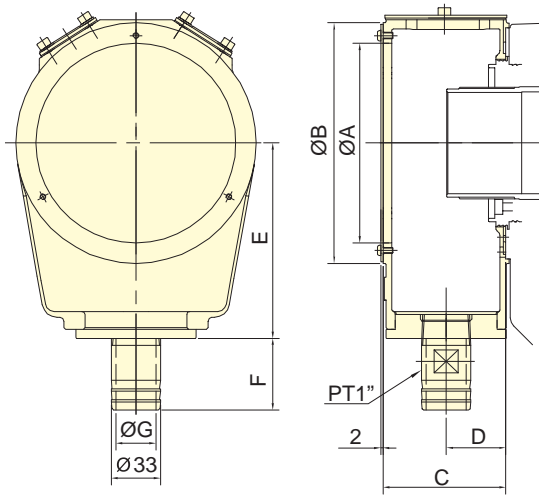

Coolant Collector

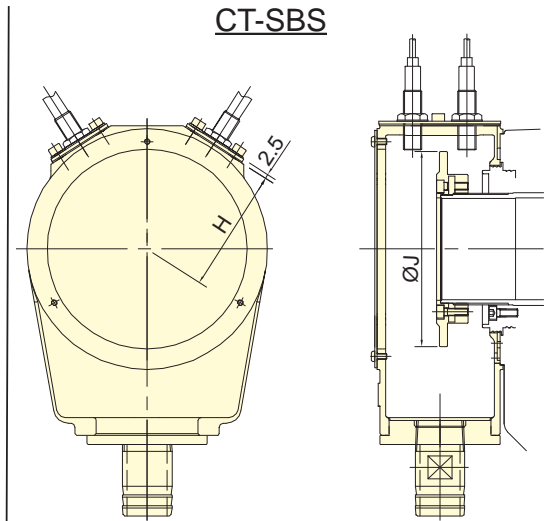

Coolant Collector with Detecting Ring

Subject to technical changes

DIMENSIONS

ड गज्ज	क	ख	ग	घ	ङ	च	चऑ	चा	छ	छऑ	छा	ज	ञ	ब वडडडडडडडड		ड डडडडडड डडडडड
														गनऑख	गनऑखड	
CT-S05B/CT-S05BS	97	120	68.3	33.3	96	49.6	56	-	25	32	-	62	86	1.1	1.6	TS-539, TR-539
CT-S08B/CT-S08BS	133	160	82	40	130	49.6	56	63	25	32	52	82	130	0.9	1.4	TS-866
CT-S10B/CT-S10BS	160	188	88	43	148	49.6	56	63	25	32	52	96	148	1.16	2.9	TS-1081



Model:FV-01

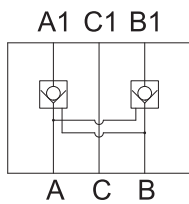

Circuit drawing

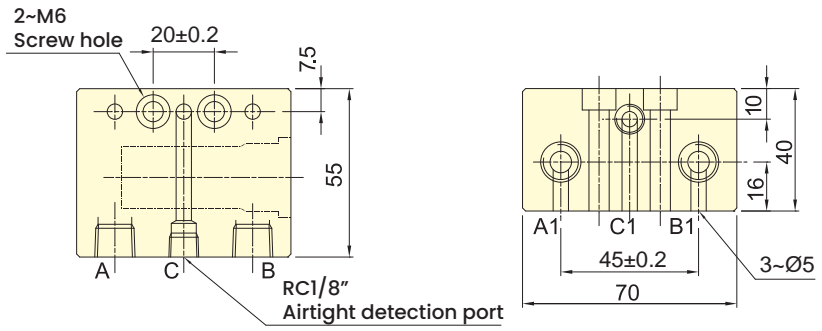

Model:FV-03

Subject to technical changes

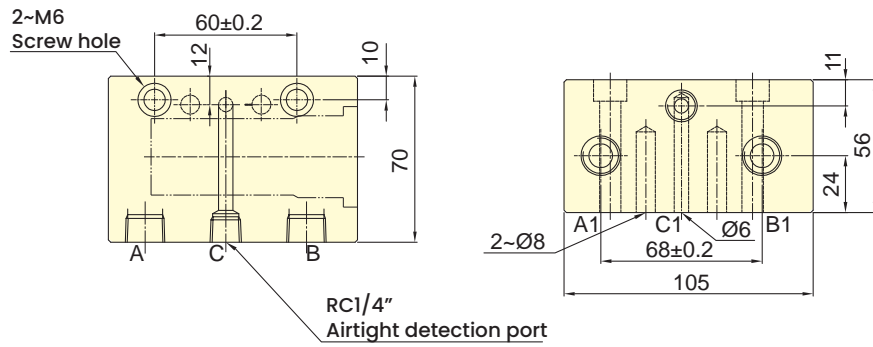

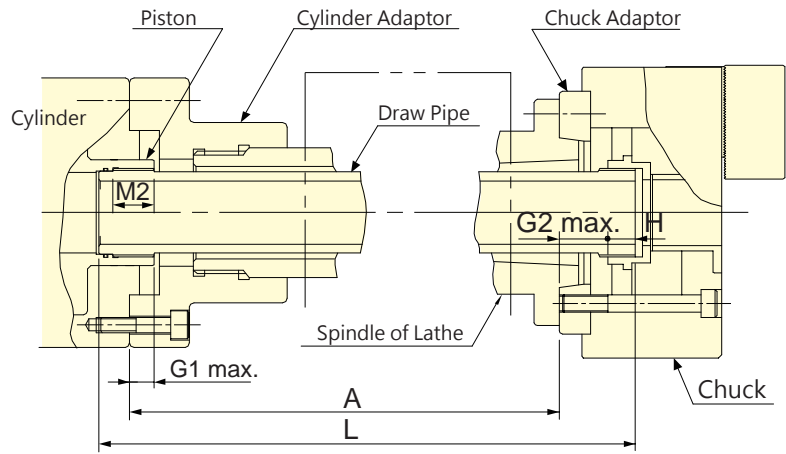
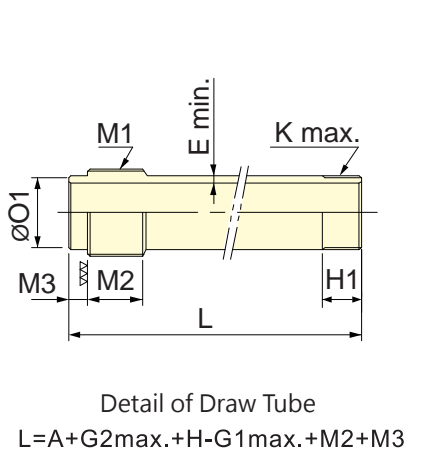

Subject to technical changes

SPECIFICATIONS

गजसुपुडक	गडसुपुडक	छऑ कहओ	ज	ड 3	ड 1	छा कहओ	ड ऑ	जऑ	णऑ		ट कहओ	ड कडओ	ठ	
									खल	कहओ				
3H-12	A8	TK-A1291	30	23	12	35	28	M100x2	35	95	-0.036 -0.071	M100x2	5	A+56+12
3H-15	A11	TK-A1512	30	33	12	45	33	M130x2	45	125	-0.043 -0.083	M130x2	5	A+81+12
3H-18	A11	TK-A1512	30	33	12	45	33	M130x2	45	125	-0.043 -0.083	M130x2	5	A+81+12

गजसुपुडक	गडसुपुडक	छऑ कहओ	ज	ड 3	ड 1	छा कहओ	ड ऑ	जऑ	णऑ		ट कहओ	ड कडओ	ठ	
									खल	कहओ				
3H-204	A4	TK-A528	12	14.5	10	25	31.5	M38x1.5	20	35	-0.025 -0.05	M38x1.5	5	A+59+10
3H-205	A4	TK-A533	12	17	10	25	16	M38x1.5	25	35	-0.025 -0.05	M45x1.5	5	A+46+10
3H-206	A5	TK-A646	15	14	10	25	28	M55x2	20	50	-0.025 -0.05	M60x2	5	A+52+10
3H-208	A6	TK-A853	20	16.5	12	30	33.5	M60x2	20	55	-0.03 -0.06	M75x2	5	A+60+12
3H-210	A8	TK-A1075	25	21	12	35	28.5	M85x2	25	80	-0.03 -0.06	M95x2	5	A+59.5+12
3H-212	A11	TK-A1512	30	23	12	45	32	M130x2	30	125	-0.043 -0.083	M115x2	5	A+70+12
3H-215	A8	TK-2114	35	33	17	45	44	M155x2	40	145	-0.043 -0.083	M115x2	5	A+87+17
3H-215	A11	TK-2114	35	33	17	45	51	M155x2	40	145	-0.043 -0.083	M155x3	5	A+93+17
3H-215	A15	TK-2114	35	33	17	45	38	M155x2	40	145	-0.043 -0.083	M155x3	5	A+81+17
3H-18B	A15	TK-2416	35	35	17	45	45	M180x3	40	170	-0.043 -0.083	M175x3	5	A+90+17
3H-221	A15	TK-2416	35	34	17	45	42	M180x3	40	170	-0.043 -0.083	M190x3	5	A+86+17
3H-224	A20	TK-2820	51	35	17	45	42	M220x3	40	210	-0.050 -0.096	M225x3	5	A+71+17
3H-232	A20	TK-2820	51	37	17	45	51	M220x3	45	230	-0.050 -0.096	M295x3	5	A+82+17

Note: To calculate the draw-tube length of 2H, 4H as 3H, 3H-2.

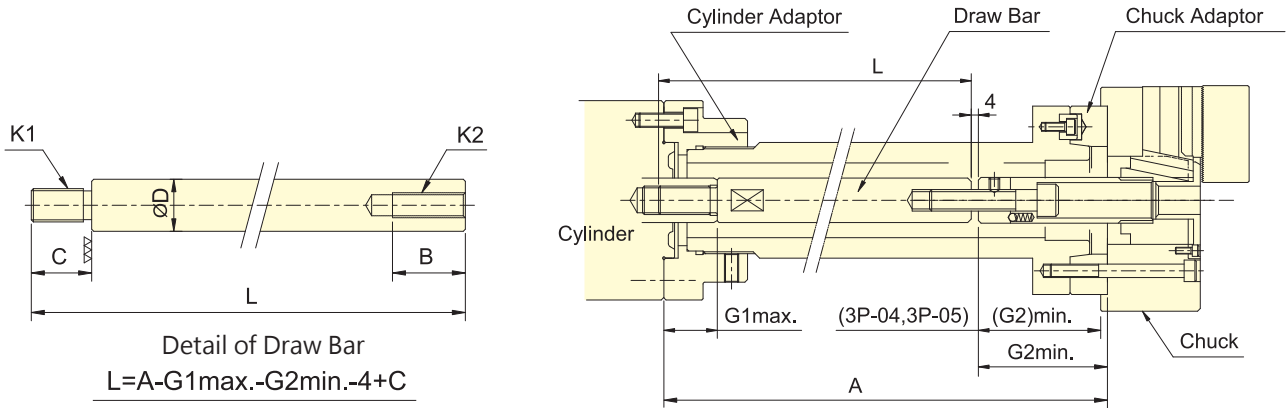

Subject to technical changes

SPECIFICATIONS

गजसुभरुदक	गदुसुभरुदक	ख	ग	घ	छऑ	छा	टऑ	टा	ठ
					कदुऑ	कदुऑ			
3P-04	RK-75(N)/RA-130	30	30/20	30/25	45	3	M20x2.5/M16x2	M10x1.5	A-22/A-32
3P-05	RK-75(N)/RA-130	40	30/20	30/25	45	-6	M20x2.5/M16x2	M12x1.75	A-13/A-23
3P-06	RK-100(N)/RA-170	40	30/25	30/25	45	81.5	M20x2.5/M16x2	M16x2	A-101/A-106
3P-08	RK-125(N)/RA-220	40	40/30	35/30	50	106	M24x3/M20x2.5	M20x2.5	A-120/A-130
3P-10	RK-125(N)/RA-220	40	40/30	35/30	50	133	M24x3/M20x2.5	M20x2.5	A-147/A-157
3P-12	RK-150(N)/RA-270	40	40/35	45/35	55	133	M30x3.5/M24x3	M20x2.5	A-152/A-157
3P-215	RK-200(N)/RH-200	60	55	55	70	69	M36x4	M30x3.5	A-88
3P-218	RK-200(N)/RH-200	60	55	55	70	57	M36x4	M30x3.5	A-76
3P-221	RK-200(N)/RH-200	60	55	55	70	62	M36x4	M30x3.5	A-81
3P-224	RK-200(N)/RH-200	60	55	55	70	62	M36x4	M30x3.5	A-81

Note: To calculate the draw-bar length of 2P as 3P.

गजसुभरुदक	गदुसुभरुदक	ख	ग	घ	छऑ	छा	टऑ	टा	ठ
					कदुऑ	कदुऑ			
3M-05	RK-75(N)	40	30	30	45	-2	M20x2.5	M12x1.75	A-17
3M-06	RK-100(N)	40	30	30	45	81.5	M20x2.5	M16x2	A-101
3M-08	RK-125(N)	40	40	35	50	106	M24x3.0	M20x2.5	A-120
3M-10	RK-150(N)	40	40	35	50	135	M24x3.0	M20x2.5	A-148
3M-12	RK-150(N)	50	40	45	55	40	M30x3.5	M24x3	A-59

Note: To calculate the draw-bar length of 2M as 3M.



AUTOGrip[®]
www.autogrip.com.tw

We reserve the right to modify the specifications without prior notice.



AUTOGrip MACHINERY CO., LTD.

No. 229, Sec. 1, Mingsheng Rd., Puxin Township,
Changhua County 513006, Taiwan

T +886-4-822-8719

F +886-4-823-5719

E sales@autogrip.com.tw

www.autogrip.com.tw