

REIME

NORIS

UNSERE PRÄZISION IST IHR ERFOLG

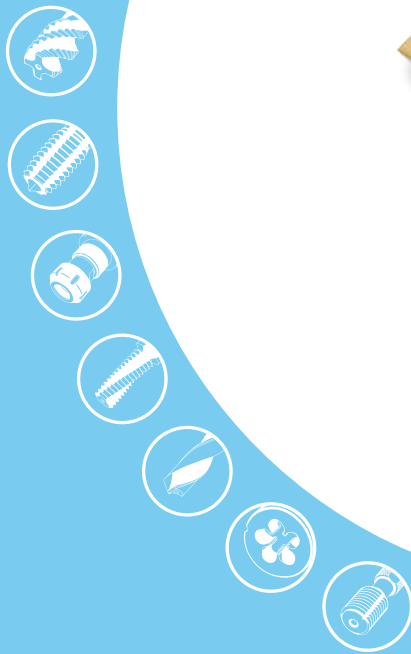

HAUPTKATALOG

MAIN CATALOGUE
CATALOGUE PRINCIPAL
CATALOGO PRINCIPALE



Quality 
Made in Germany 
ISO 9001 CERTIFIED

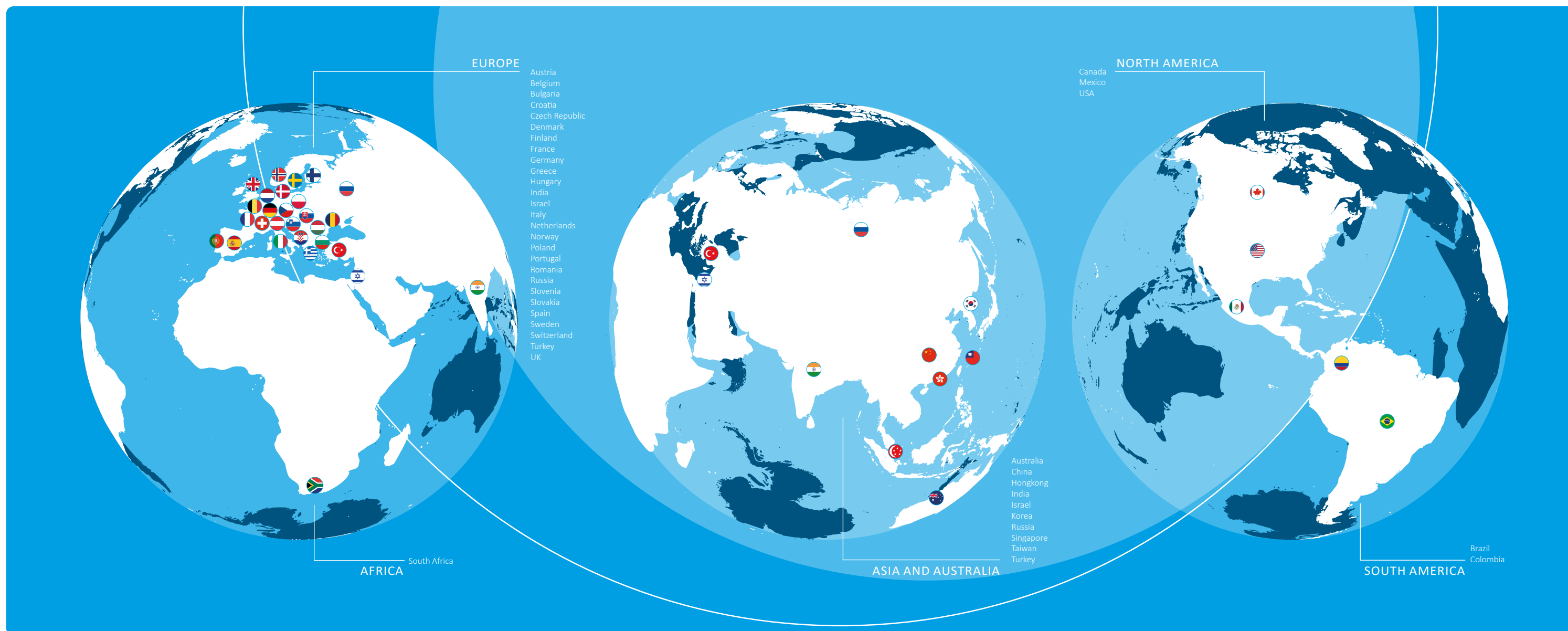

Die immer weiter steigenden Anforderungen der Industrie in der Gewindeherstellung sind nur mit Qualitätsprodukten zu lösen. NORIS Gewindewerkzeuge von REIME garantieren Präzision und Prozesssicherheit in der Fertigung. Weltweite Präsenz, Kundennähe und unsere Gewinde-Spezialisten sind dabei die Garanten zur Herstellung von hochgenauen Gewinden mit NORIS-Werkzeugen.



The still further increasing demands by the industry on threading tools only can be met by high quality products. NORIS threading tools from REIME guarantee precision and a safe manufacturing process. In this context a worldwide presence, customer proximity and our threading specialists guarantee the manufacture of high-precision threads by NORIS tools.



Seuls des produits de qualité peuvent répondre aux exigences toujours croissantes de l'industrie dans le domaine de la fabrication de filets. Les outils à fileter NORIS de REIME garantissent précision et fiabilité de processus lors de la fabrication. Notre présence à l'échelle mondiale, notre assistance clients et nos spécialistes en filets sont les garants d'une fabrication de haute précision grâce aux outils NORIS.



Le richieste dell'industria alla produzione di filettature sono in crescente aumento e possono soltanto essere soddisfatte con prodotti di alta qualità. Gli utensili per filettare NORIS, prodotti da REIME, garantiscono precisione e sicurezza nel processo di produzione. La presenza internazionale e la vicinanza al cliente dei nostri specialisti nella filettatura garantiscono un'altissima precisione dei filetti realizzati con gli utensili NORIS.

KAPITELÜBERSICHT

Chapter overview
Présentation du chapitre
Panoramica del capitolo

GEWINDEBOHRER

Machine taps / Tarauds machine / Maschi a macchina

Seite 6 - 93

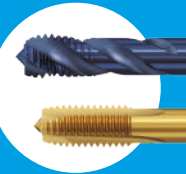

GEWINDEFORMER

Cold forming taps / Tarauds à refouler / Maschi a rullare

Seite 94 - 105



GEWINDESCHNEIDFUTTER

Tap holders / Mandrins de taraudage / Mandrini

Seite 106 - 139

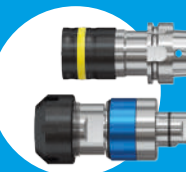

GEWINDEFRÄSER

Thread mills / Fraises à fileter / Fresa a filettare

Seite 140 - 155

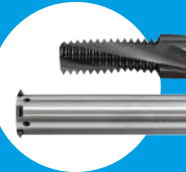

SPIRALBOHRER

Twist Drills / Foret / Punta Elicoidale

Seite 156 - 165

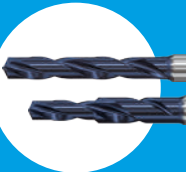

SCHNEIDEISEN

Dies / Filières / Filiere

Seite 166 - 179



GEWINDELEHREN

Thread gauges / Calibres de contrôle / Calibri filettati

Seite 180 - 189

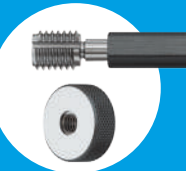

ALLGEMEINE INFORMATIONEN

General Informations / Informations générales / Informazioni generali

Seite 190 - 265



GEWINDEBOHRER

Machine taps
Tarauds machine
Maschi a macchina



AUSKLAPPSEITE

Fold-out page
Page-dépliant
Pieghevole

AUSWAHLÜBERSICHT

DIE ANGEGEBENEN SCHNITTGESCHWINDIGKEITEN (VC IN M/MIN) SIND RICHTWERTE UND MÜSSEN DEN INDIVIDUELLEN ARBEITSBEDINGUNGEN ANGEPAST WERDEN.

* Für konische und Tr-Gewinde müssen die Schnittwerte um 50% reduziert werden.

GUIDE DE SELECTION

LES VALEURS DE VITESSE DE COUPE (VC EN M/MIN) INDIQUÉES DANS LES COLONNES RESPECTIVES NE SONT QU'INDICATIVES ET DOIVENT ÊTRE ADAPTÉES INDIVIDUELLEMENT AUX CONDITIONS D'USINAGE.

* Pour les filetages coniques et trapézoïdaux les valeurs de coupe doivent être réduites de 50%.

SUMMARY OF ASSORTMENT

THE LISTED CUTTING SPEEDS (VC IN M/MIN) ARE STANDARD VALUES. THIS VALUES HAVE TO BE ADJUSTED TO INDIVIDUAL WORK CONDITIONS.

* For conical threads and trapezoidal threads the cutting speeds have to be reduced by 50%.

SCelta DEGLI UTENSILI

I VALORI DI VELOCITÀ DI TAGLIO (VC IN M/MIN) QUI ELENCATI SONO PURAMENTE INDICATIVI E DEVONO ESSERE ADATTATI ALLE CONDIZIONI D'IMPIEGO.

* Per filetti conici e filetti trapezoidali le velocità di tagli o devono essere ridotte del 50 %.

SACKLOCH-GEWINDE/BLINDHOLETHREADS



TROUSBORGNE/FORICIECHI

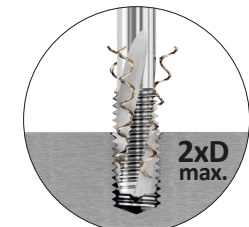

DURCHGANGSLOCH-GEWINDE/THROUGHHOLETHREADS



TROUSDÉBOUCHANTS/FORIPASSANTI



DURCHGANGSLOCH+SACKLOCH-GEWINDE/THROUGHHOLETHREADS+BLINDHOLETHREADS

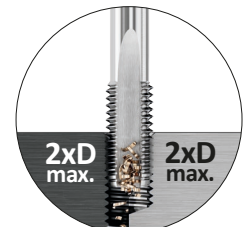

Material and tool compatibility table with icons for various materials like M, MF, UNC, UNF, UNF|UN8, G, Rp/Rc, BSW, BSF, W, NPT/NPTF, NPSM/NPSF, MJ|UNIC|UNJF, EG(St), TR, Rd/Pg.

Technical data table for NORISSALOREX series including UNI, ST, HR, VA, VR, NW, and SOFT variants with Vc and Fc values.

Technical data table for NORISSL15/SL25/SL30 series including UNI, ST, HR, TI, and NI variants with Vc and Fc values.

Technical data table for NORISSTABIL series including UNI, ST, HR, VA, NW, SOFT, and TI variants with Vc and Fc values.

Technical data table for NORISDL15 series including ST, TI, and NI variants with Vc and Fc values.

Technical data table for NORISTWIN series including ST, VG, HR, GG, GGV, MS, AMPCO, MG, and HT variants with Vc and Fc values.

Technical data table for NORISINNENSPAN RA15 series with Vc and Fc values.

Technical data table for SATZ ERGO ERGOFIT series with Vc and Fc values.

Language selection icons for German, British, and French.

Material selection table with columns for material types (P, M, K, N, S, H), material names in German, English, and French, material grades, and application icons.

Technical data table for NORISSALOREX series (continued) with Vc and Fc values for various materials.

Technical data table for NORISSL15/SL25/SL30 series (continued) with Vc and Fc values for various materials.

Technical data table for NORISSTABIL series (continued) with Vc and Fc values for various materials.

Technical data table for NORISDL15 series (continued) with Vc and Fc values for various materials.

Technical data table for NORISTWIN series (continued) with Vc and Fc values for various materials.

Technical data table for NORISINNENSPAN RA15 series (continued) with Vc and Fc values for various materials.

Technical data table for SATZ ERGO ERGOFIT series (continued) with Vc and Fc values for various materials.

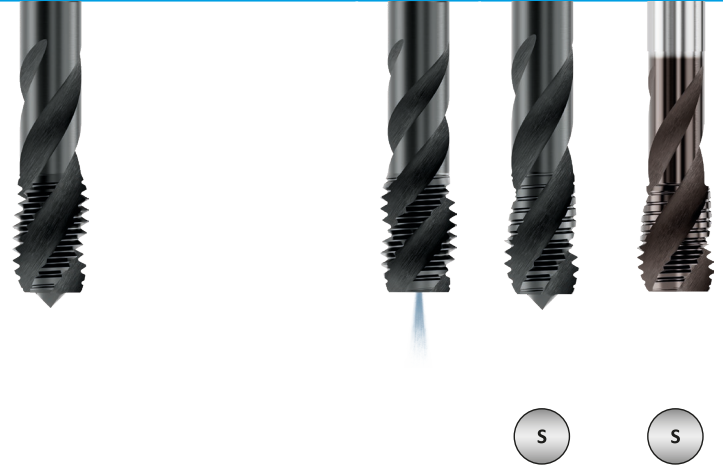
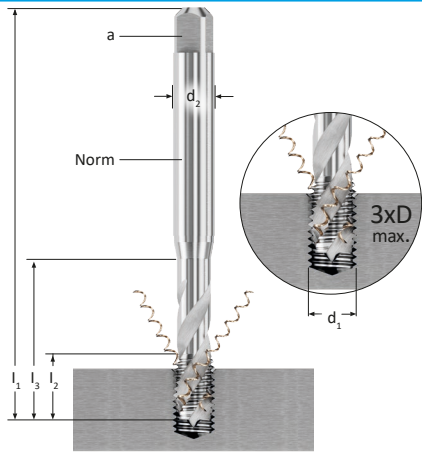

OBERFLÄCHE / SURFACE SURFACE / SUPERFICIE											VAP					ALTiNHD			
SCHNEIDSTOFF / MATERIAL MATIÈRE / MATERIALE											HSSE					HSSE			
ANSCHNITTFORM / CHAMFER FORM FORME D'ENTRÉE / FORMA D'IMBOCCO											C / 2-3			E / 1,5-2		E / 1,5-2	C / 2-3		C / 2-3
d ₁	P		NORM	l ₁	l ₂	l ₃	d ₂	a	ISO1	ISO2	7G	ISO2	ISO3	ISO2	ISO2	ISO2			
M 2	0,4	1,6	DIN 371	45	4	12	2,8	2,1		6642ABEAA									
M 2,2	0,45	1,75	DIN 371	45	4,5	12	2,8	2,1		6642ABFAA									
M 2,3	0,4	1,9	DIN 371	45	4,4	12	2,8	2,1		6642ABGAA									
M 2,5	0,45	2,05	DIN 371	50	5	14	2,8	2,1		6642ABHAA									
M 2,6	0,45	2,15	DIN 371	50	5	14	2,8	2,1		6642ABIAA									
M 3	0,5	2,5	DIN 371 DIN 376	56 56	5 6	18 -	3,5 2,2	2,7 -	6642ADHAA	6642ABJAA 7642AJUAA	6642AMSAA	6642ABJAU	6642AHDAB			6652AARAA			
M 3,5	0,6	2,9	DIN 371	56	7	20	4	3		6642ADJAA	6642ABKAA	6642A4204				6652AAHAA			
M 4	0,7	3,3	DIN 371 DIN 376	63 63	7 7	21 -	4,5 2,8	3,4 2,1	6642ADKAA	6642ABLAA 7642AJVAA	6642AIXAB	6642ABLA1	6642AEUAA			6652AAHAA			
M 5	0,8	4,2	DIN 371 DIN 376	70 70	8 8	25 -	6 3,5	4,9 2,7	6642ADLAA	6642ABMAA 7642AJWAA	6642AIYAB	6642ABMA9	6642AD3AC	6852AAAAA	6652AAAAA				
M 6	1	5	DIN 371 DIN 376	80 80	10 10	30 -	6 4,5	4,9 3,4	6642ADMAA	6642ABNAA 7642ADWAB	6642AK0AA	6642ABNBW	6642AEJAD	6852AABAA	6652AABAA				
M 7	1	6	DIN 371	80	10	30	7	5,5	6642ADNAA	6642ABPAA 7642AFCAK	6642AF7AA	6642ABPBS	6642AIGAG	6852AACAA	6652AACAA				
M 8	1,25	6,8	DIN 371 DIN 376	90 90	14 14	35 -	8 6	6,2 4,9	6642ADNAA	6642ABQAA 7642AEPAB	6642AF8AA	6642ABQBQ	6642AFPAC	6852AADAA	6652AADAA				
M 10	1,5	8,5	DIN 371 DIN 376	100 110	16 18	39 44	10 12	8 9		6642ABRAA 7642ABCAB	6642AF8AA	6642ABQBQ	6642AFPAC	6852AADAA	6652AADAA				
M 12	1,75	10,2	DIN 371 DIN 376	110 110	18 18	44 -	12 9	9		7642ABCAB 7642ABDAA	7642ANLAA	7642ABCBQ	7642A4433	7852AAAAA	7652AAAAA				
M 14	2	12	DIN 371 DIN 376	110 110	20 22	11 -	9	9		7642ABDAA 7642ABEAB	7642A4092	7642ABEBM	7642A4435	7852AABAA	7652AABAA				
M 16	2	14	DIN 371 DIN 376	125 125	25 -	14 -	11	11		7642ABFAB 7642ABGAB	7642A4092	7642ABEBM	7642A4435	7852AACAA	7652AACAA				
M 18	2,5	15,5	DIN 371 DIN 376	140 140	25 27	16 -	12	12		7642ABHAB 7642ABIAA	7642A4093	7642ABGA9	7642A4437	7852AADAA	7652AAEAA				
M 20	2,5	17,5	DIN 371 DIN 376	140 160	30 30	18 -	14,5	14,5		7642ABIAA 7642AA8AA	7642A4218	7642A4218					7652S0559739		
M 22	2,5	19,5	DIN 371 DIN 376	160 180	30 35	18 -	18	18		7642AA8AA 7642AA9AA							7652S0559743		
M 24	3	21	DIN 371 DIN 376	180 180	35 -	25 -	20	20		7642ABAAA 7642ABBAA							7652S0559747		
M 27	3	24	DIN 371 DIN 376	200 200	40 35	28 -	22	24									7652S0559750		
M 30	3,5	26,5	DIN 371 DIN 376	200 200	40 35	32 -	24	24									7652S0559755		
M 33	3,5	29,5	DIN 371 DIN 376	200 220	40 58	32 -	24	29									7652S0559759		
M 36	4	32	DIN 371 DIN 376	200 220	40 58	32 -	24	29									7652S0559763		
M 39	4	35	DIN 371 DIN 376	250 250	65 65	36 -	29	29									7652S0559767		
M 42	4,5	37,5	DIN 371 DIN 376	250 250	65 65	36 -	29	29									7652S0559774		
M 45	4,5	40,5	DIN 371 DIN 376	250 250	65 65	40 -	32	32									7652S0559780		



TIN		TICN	ALTiNHD				-	TIN	
HSSE		HSSE	HSSE				HSSE	HSSE	
C / 2-3	E / 1,5-2	C / 2-3	C / 2-3		E / 1,5-2	C / 2-3	C / 2-3		
ISO2	ISO2	ISO2	ISO2	ISO3	7G	ISO2	ISO2X	ISO2X	d ₁ P
6642ABEAB									M 2 0,4
									M 2,2 0,45
									M 2,3 0,4
6642B0180									M 2,5 0,45
									M 2,6 0,45
6642ABJAB	6642ABJAV	6642ABJAR	6470F0002	6470F0007	6470F0008		666CB0284	666CB0293	M 3 0,5
									M 3,5 0,6
6642ABLAB	6642ABLA2	6642ABLAU	6470F0003	6470F0009	6470F0010		666CB0285	666CB0294	M 4 0,7
6642ABMAB	6642ABMBB	6642ABMA4	6470F0004	6470F0011	6470F0012	6480F0001	666CB0286	666CB0295	M 5 0,8
6642ABNAB	6642ABNB3	6642ABNBK	6470F0005	6470F0013	6470F0014	6480F0002	666CB0287	666CB0296	M 6 1
									M 7 1
6642ABPAB	6642ABPBU	6642ABPBG	6470F0006	6470F0015	6470F0016	6480F0003	666CB0288	666CB0297	M 8 1,25
6642ABQAB	6642ABQBT	6642ABQBG	6470F0001	6470F0017	6470F0018	6480F0004	666CB0289	666CB0298	M 10 1,5
6642ABRAB		6642ABRA0							M 12 1,75
7642ABCAE	7642ABCBE	7642ABCBG	7470F0001	7470F0007	7470F0008	7480B0700	766CB0675	766CB0690	M 14 2
7642A3824		7642A4190	7470F0002	7470F0009	7470F0010	7480B0701	766CB0676	766CB0691	M 16 2
7642ABEAC	7642ABEBN	7642ABEBC	7470F0003	7470F0011	7470F0012	7480B0702	766CB0677	766CB0692	M 18 2,5
7642A3826		7642A4192							M 20 2,5
7642ABGAC	7642ABGBA	7642A4193	7470F0004	7470F0013	7470F0014	7480B0703	766CB0678	766CB0693	M 22 2,5
7642A3828									M 24 3
7642A3829									M 27 3
									M 30 3,5
									M 33 3,5
									M 36 4
									M 39 4
									M 42 4,5
									M 45 4,5
									M 48 5
									M 52 5

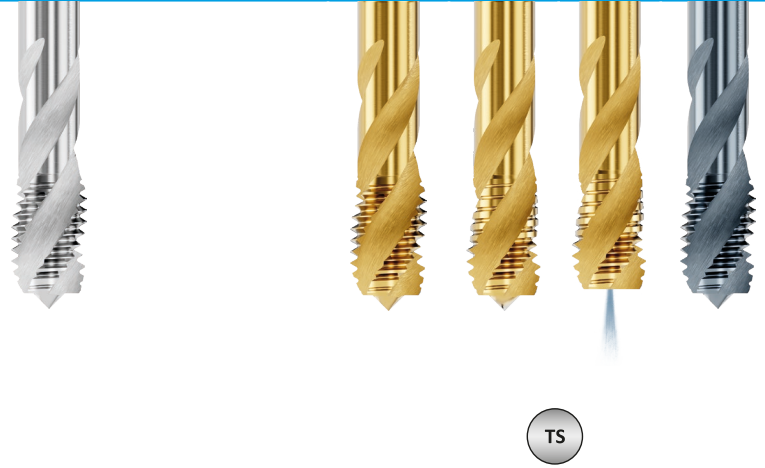
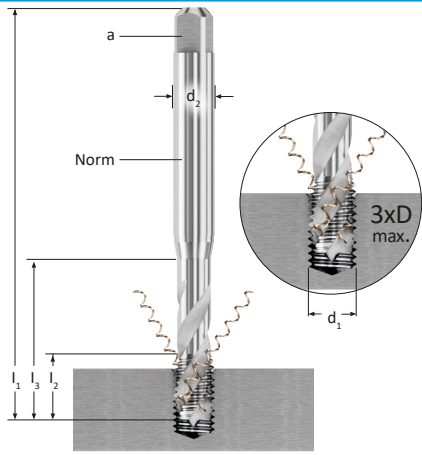

OBERFLÄCHE / SURFACE SURFACE / SUPERFICIE										-					TIN	TIN	TICN
SCHNEIDSTOFF / MATERIAL MATIÈRE / MATERIALE										HSSE					HSSE	HSSE-PM	HSSE
ANSCHNITTFORM / CHAMFER FORM FORME D'ENTRÉE / FORMA D'IMBOCCO										C / 2-3					C / 2-3	C / 2-3	C / 2-3
d ₁	P		NORM	l ₁	l ₂	l ₃	d ₂	a	ISO1	ISO2	ISO2 - LH	ISO3	7G	ISO2	ISO2	ISO2	
M 1,6	0,35	1,25	DIN 371	40	4	11	2,5	2,1									
M 2	0,4	1,6	DIN 371	45	4	12	2,8	2,1	6640AAAA	6640AA1AA		6640AANAA	6640A3772	6640AA1AB			
M 2,2	0,45	1,75	DIN 371	45	4,5	12	2,8	2,1		6640AA2AA							
M 2,3	0,4	1,9	DIN 371	45	4,4	12	2,8	2,1		6640AA3AA							
M 2,5	0,45	2,05	DIN 371	50	5	14	2,8	2,1	6640AADAA	6640AA4AA		6640AARAA	6640A3774	6640S0528581			
M 2,6	0,45	2,15	DIN 371	50	5	14	2,8	2,1		6640AA5AA							
			DIN 352	40	5	18	3,5	2,7		5640AAKAA							
M 3	0,5	2,5	DIN 371	56	5	18	3,5	2,7	6640AAFAA	6640AA6AA	6640A3791	6640AATAA	6640ADLAA	6640AA6AB		6640D00216	
			DIN 376	56	5	-	2,2	-		7640AAFAA							
M 3,5	0,6	2,9	DIN 371	56	7	20	4	3	6640AAGAA	6640AA7AA							
			DIN 352	45	7	22	4,5	3,4		5640AAMAA							
M 4	0,7	3,3	DIN 371	63	7	21	4,5	3,4	6640AAHAA	6640AA8AA	6640A3793	6640AAVAA	6640ADNAA	6640AA8AB	6880F0001	6640D00217	
			DIN 376	63	7	-	2,8	2,1		7640AAHAA							
			DIN 352	50	8	25	6	4,9		5640AANAA							
M 5	0,8	4,2	DIN 371	70	8	25	6	4,9	6640A3695	6640AA9AA	6640A3794	6640AAWAA	6640ADPAA	6640AA9AC	6880F0002	6890F0001	6640D00218
			DIN 376	70	8	-	3,5	2,7		7640AAIAA							
			DIN 352	56	10	28	6	4,9		5640AAPAA							
M 6	1	5	DIN 371	80	10	30	6	4,9	6640AAJAA	6640ABAAA	6640A3795	6640AAXAA	6640ADQAA	6640ABAAB	6880F0003	6890F0002	6640D00219
			DIN 376	80	10	-	4,5	3,4		7640AAJAA							
M 7	1	6	DIN 371	80	10	30	7	5,5		6640A3475							
			DIN 376	80	10	-	5,5	4,3									
			DIN 352	63	14	-	6	4,9		5640AAQAA							
M 8	1,25	6,8	DIN 371	90	14	35	8	6,2	6640AAKAA	6640ABCAA	6640A3796	6640AAYAA	6640A3780	6640ABCAB	6880F0004	6890F0003	6640D00220
			DIN 376	90	14	-	6	4,9	7640A3698	7640AAKAA		7640A3761	7640A3781				
			DIN 371	90	14	35	9	7		6640A3479							
M 9	1,25	7,8	DIN 376	90	14	-	7	5,5		7640A3480							
			DIN 352	70	16	-	7	5,5		5640AARAA							
M 10	1,5	8,5	DIN 371	100	16	39	10	8	6640AALAA	6640ABDAA	6640A3797	6640AAZAA	6640ADSAA	6640ABDAB	6880F0005	6890F0004	6640D00221
			DIN 376	100	16	-	7	5,5	7640A3700	7640AALAA		7640A3763	7640A3783	7640AALAX			
M 11	1,5	9,5	DIN 376	100	8	-	8	6,2		7640A3483							
			DIN 352	75	18	-	9	7		5640AASAA							
M 12	1,75	10,2	DIN 376	110	18	-	9	7	7640A3701	7640AAMAA	7640A3798	7640A3765	7640A3784	7640AAMAB	7880F0001		7640D00222
M 14	2	12	DIN 376	110	18	-	11	9		7640AANAA	7640A3799	7640A3766	7640A3785	7640AANAHA	7880F0002		7640K00415
M 16	2	14	DIN 376	110	18	-	12	9	7640A3704	7640AAPAA	7640A3800	7640A3767	7640A3786	7640AAPAB	7880A4534		7640D00223
M 18	2,5	15,5	DIN 376	125	20	-	14	11		7640AAQAB							
M 20	2,5	17,5	DIN 376	140	22	-	16	12	7640A3706	7640AARAC	7640A3802	7640A3769	7640A3788	7640AARAB			7640D00224
M 22	2,5	19,5	DIN 376	140	25	-	18	14,5		7640AASAB					7640D00170		
M 24	3	21	DIN 376	160	25	-	18	14,5		7640AATAA	7640A3804	7640A3771	7640A3790	7640D00171			
M 27	3	24	DIN 376	160	27	-	20	16		7640AAAAA							
M 30	3,5	26,5	DIN 376	180	30	-	22	18		7640AABAA					7640D00172		
M 33	3,5	29,5	DIN 376	180	30	-	25	20		7640AACAA					7640D00173		
M 36	4	32	DIN 376	200	35	-	28	22		7640AADAA					7640D00174		
M 39	4	35	DIN 376	200	35	-	32	24		7640A3499					7640D00175		
M 42	4,5	37,5	DIN 376	200	40	-	32	24		7640A3500					7640D00176		
M 45	4,5	40,5	DIN 376	220	58	-	36	29		7640A3501					7640D00177		
M 48	5	43	DIN 376	250	65	-	36	29		7640A3502					7640D00178		
M 52	5	47	DIN 376	250	65	-	40	32		7640A3503							

HR

NORIS SALOREX
VA

VR

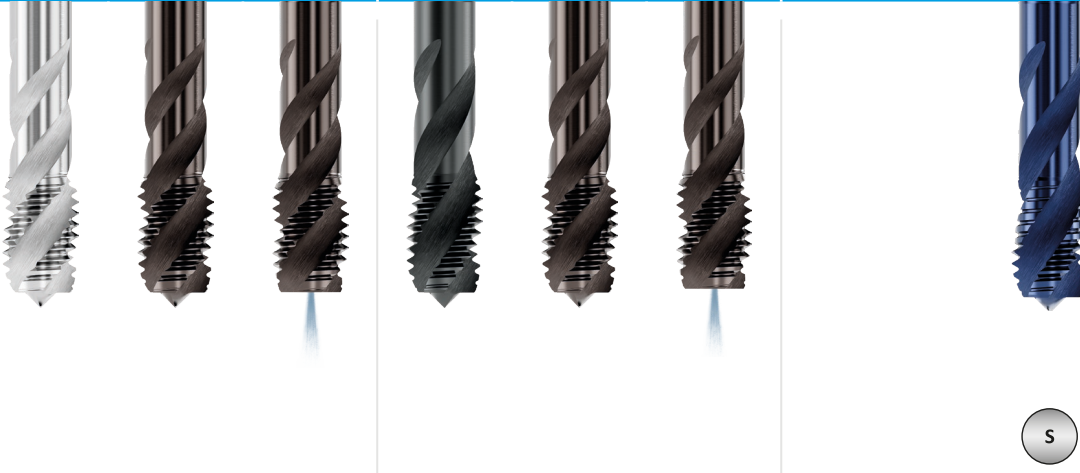

-	ALTiNHd		VAP	ALTiNHd		TiBLU					
HSSE-PM	HSSE-PM		HSSE	HSSE		HSSE-PM					
C / 2-3	C / 2-3		C / 2-3	C / 2-3	E / 1,5-2	C / 2-3		E / 1,5-2			
ISO2	ISO2	ISO2	ISO2	ISO2	ISO2	ISO2X	ISO3X	ISO2X	ISO3X	d ₁	P
				6645F0040						M 1,6	0,35
			6645AAEAA	6645F0041						M 2	0,4
										M 2,2	0,45
			6645AACAA	6645F0042						M 2,3	0,4
										M 2,5	0,45
										M 2,6	0,45
6643AADAA	6643AADAD		6645ABAAA	6645F0008		6655K00131	6655K00132	6655K00154	6655K00155	M 3	0,5
										M 3,5	0,6
6643AAEAA	6643AAEAD		6645AA3AA	6645F0009		6655K00133	6655K00134	6655K00156	6655K00157	M 4	0,7
6643AAFAA	6643AAFAD	6853F0002	6645ABBAA	6645F0010	6855F0001	6655K00135	6655K00136	6655K00158	6655K00159	M 5	0,8
6643AAGAA	6643AAGAD	6853F0003	6645AA7AA	6645F0011	6855F0002	6655S0544886	6655K00138	6655S0544917	6655S0545028	M 6	1
										M 7	1
6643AAAAA	6643AAAAD	6853F0004	6645AA0AA	6645F0012	6855F0003	6655K00139	6655K00140	6655K00162	6655K00163	M 8	1,25
6643AAHAA	6643AAHAD	6853F0005	6645ABCAA	6645F0013	6855F0004	6655K00141	6655K00142	6655K00164	6655K00165	M 10	1,5
7643F0196	7643F0172	7853F0007	7645AAXAA	7645F0012	7855K00270	7655K00196	7655K00197	7655K00236	7655K00237	M 12	1,75
7643F0197	7643F0173	7853F0008	7645ABAAA	7645F0013	7855K00271	7655K00201		7655K00241		M 14	2
7643F0198	7643F0174	7853F0009	7645ABLAA	7645F0014	7855K00272	7655K00203	7655K00204	7655K00243	7655K00244	M 16	2
7643F0199	7643F0175	7853F0010								M 18	2,5
7643F0200	7643F0176	7853F0011	7645ABEAA	7645F0015	7855K00273	7655K00207	7655K00208	7655K00247	7655K00248	M 20	2,5
			7645AALAA							M 22	2,5
			7645ABQAA			7655K00211	7655K00212	7655K00251	7655K00252	M 24	3
										M 27	3
			7645AA7AA			7655K00214	7655K00215	7655K00254	7655K00255	M 30	3,5
										M 33	3,5
										M 36	4
										M 39	4
										M 42	4,5
										M 45	4,5
										M 48	5
										M 52	5

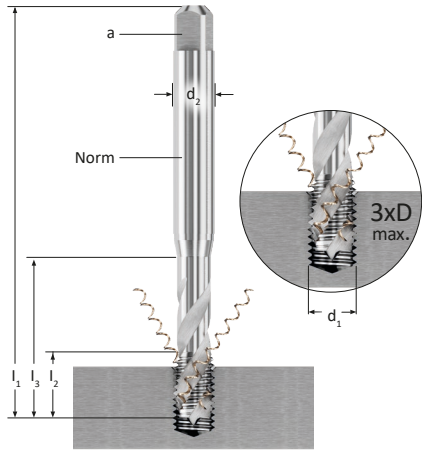

OBERFLÄCHE / SURFACE SURFACE / SUPERFICIE										DLC			-			DLC		
SCHNEIDSTOFF / MATERIAL MATIÈRE / MATERIALE										HSSE			HSSE			HSSE		
ANSCHNITTFORM / CHAMFER FORM FORME D'ENTRÉE / FORMA D'IMBOCCO										C / 2-3			C / 2-3			C / 2-3		
d ₁	P		NORM	l ₁	l ₂	l ₃	d ₂	a		ISO2			ISO2			ISO2		
M 2	0,4	1,6	DIN 371	45	4	12	2,8	2,1		6641K00123			664SB0234			664SB0164		
M 2,5	0,45	2,05	DIN 371	50	5	14	2,8	2,1		6641K00124			664SB0235			664SB0165		
M 3	0,5	2,5	DIN 371	56	5	18	3,5	2,7		6641F0095			664SB0236			664SB0166		
M 4	0,7	3,3	DIN 371	63	7	21	4,5	3,4		6641F0096			664SB0237			664SB0167		
M 5	0,8	4,2	DIN 371	70	8	25	6	4,9		6641F0097			664SB0238			664SB0168		
M 6	1	5	DIN 371	80	10	30	6	4,9		6641F0098			664SB0239			664SB0169		
M 8	1,25	6,8	DIN 371	90	14	35	8	6,2		6641F0099			664SB0240			664SB0170		
M 10	1,5	8,5	DIN 371	100	16	39	10	8		6641F0100			664SB0241			664SB0171		
M 12	1,75	10,2	DIN 376	110	18	-	9	7		7641F0089						764SF0001		
M 14	2	12	DIN 376	110	20	-	11	9		7641F0090								
M 16	2	14	DIN 376	110	22	-	12	9		7641F0091						764SF0002		
M 20	2,5	17,5	DIN 376	140	25	-	16	12		7641F0092								



SOLUTIONS@NORIS-REIME.DE

Das REIME Team steht Ihnen bei der Lösung Ihrer Zerspanungsaufgabe gerne zur Seite

The REIME team will be happy to solve your threading tasks

L'équipe de REIME se tient à votre disposition pour résoudre vos problèmes de filetage

Il team REIME sarà lieto di risolvere i vostri problemi di filettatura

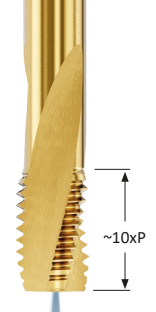
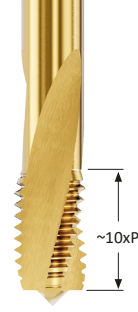
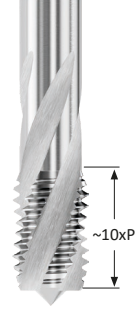
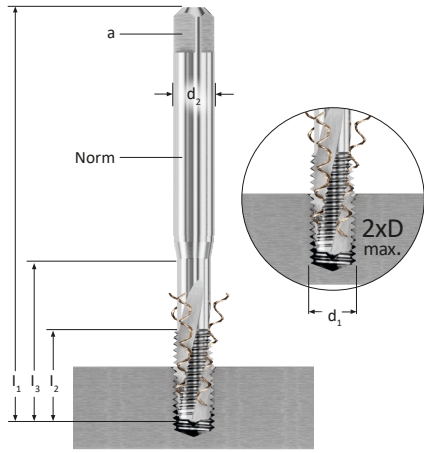

OBERFLÄCHE / SURFACE SURFACE / SUPERFICIE										-		TIN		TIN	
SCHNEIDSTOFF / MATERIAL MATIÈRE / MATERIALE										HSSE		HSSE-PM		HSSE	
ANSCHNITTFORM / CHAMFER FORM FORME D'ENTRÉE / FORMA D'IMBOCCO										C / 2-3		C / 2-3		C / 2-3	
d ₁	P		NORM	l ₁	l ₂	l ₃	d ₂	a	ISO2	ISO2	ISO2	ISO2X	ISO2X		
M 2	0,4	1,6	DIN 371	45	7	12	2,8	2,1		6600ABEAA					
M 2,5	0,45	2,05	DIN 371	50	9	14	2,8	2,1		6600ABHAA					
M 3	0,5	2,5	DIN 352	40	10	18	3,5	2,7		5600ABZAA					
M 3	0,5	2,5	DIN 371	56	11	18	3,5	2,7	6602F0014	6600F0048		660CB0124			
M 4	0,7	3,3	DIN 371	63	13	21	4,5	3,4	6602F0015	5600AB1AA	6900AAAAA	660CB0125			
M 4	0,7	3,3	DIN 376	63	13	-	2,8	2,1		7600ACGAA					
M 5	0,8	4,2	DIN 352	50	14	25	6	4,9	6602F0016	5600AB2AA	6900AABAA	660CB0126	684CB0305		
M 5	0,8	4,2	DIN 371	70	15	25	6	4,9		6600F0050					
M 5	0,8	4,2	DIN 376	70	15	-	3,5	2,7		7600ACHAA					
M 6	1	5	DIN 352	56	16	28	6	4,9	6602F0017	5600AB3AA	6900AACAA	660CB0127	684CB0306		
M 6	1	5	DIN 371	80	17	30	6	4,9		6600F0051					
M 6	1	5	DIN 376	80	17	-	4,5	3,4		7600ACIAA					
M 8	1,25	6,8	DIN 352	63	20	-	6	4,9	6602F0018	5600AB4AA	6900AADAA	660CB0128	684CB0307		
M 8	1,25	6,8	DIN 371	90	20	35	8	6,2		6600F0052					
M 8	1,25	6,8	DIN 376	90	20	-	6	4,9		7600ACJAA					
M 10	1,5	8,5	DIN 352	70	22	-	7	5,5	6602F0019	5600AB5AA	6900AAEAA	660CB0129	684CB0308		
M 10	1,5	8,5	DIN 371	100	22	39	10	8		6600F0053					
M 10	1,5	8,5	DIN 376	100	22	-	7	5,5		7600ACKAA					
M 12	1,75	10,2	DIN 352	75	24	-	9	7		5600AB6AA					
M 12	1,75	10,2	DIN 371	110	24	44	12	9	7602F0030	7600F0098	7900AAJAA	760CB0544	784CB0694		
M 12	1,75	10,2	DIN 376	110	24	-	9	7		7600ACMAA					
M 14	2	12	DIN 371	110	26	-	11	9	7602F0031	7600F0099		760CB0545	784CB0695		
M 16	2	14	DIN 376	110	27	-	12	9							
M 18	2,5	15,5	DIN 376	125	30	-	14	11							
M 20	2,5	17,5	DIN 376	140	32	-	16	12	7602F0032	7600F0100		760CB0546			
M 24	3	21	DIN 376	160	34	-	18	14,5		7600ACSA					
M 27	3	24	DIN 376	160	36	-	20	16		7600ABRAA					
M 30	3,5	26,5	DIN 376	180	40	-	22	18		7600ABSAA					
M 33	3,5	29,5	DIN 376	180	40	-	25	20		7600ABTAA					
M 36	4	32	DIN 376	200	50	-	28	22		7600ABUAA					
M 39	4	35	DIN 376	200	50	-	32	24		7600ABVAA					
M 42	4,5	37,5	DIN 376	200	56	-	32	24		7600ABWAA					
M 45	4,5	40,5	DIN 376	220	58	-	36	29		7600ABXAA					
M 48	5	43	DIN 376	250	65	-	36	29		7600ABYAA					
M 52	5	47	DIN 376	250	65	-	40	32		7600ABZAA					

NORIS SL25
HR

NORIS SL15
Ti+

NORIS SL30
Ti

NORIS SL15
Ni

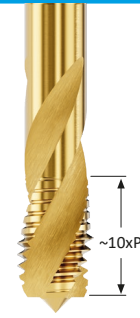

-	ALTiNHD		TiCN	VAP	TiN	TiCN	
HSSE-PM	HSSE-PM		HSSE	HSSE-PM	HSSE-PM	HSSE-PM	
C / 2-3	C / 2-3		C / 2-3	C / 2-3	C / 2-3	C / 2-3	
ISO2	ISO2	ISO2	ISO2X	ISO2X	ISO2X	ISO2X	d ₁ P
							M 2 0,4
							M 2,5 0,45
6603AAFAA	6603D00370		66B4RC000305	6614AAAAA	6614AAAAB	66A7B0375	M 3 0,5
6603AAHAA	6603D00371		66B4RC000405	6614AACAA	6614AACAB	66A7B0376	M 4 0,7
6603AAIAA	6603D00372	6843K00171	66B4RC000505	6614AADAA	6614AADAB	66A7B0377	M 5 0,8
6603AAJAA	6603D00373	6843K00172	66B4RC000605	6614AAEAA	6614AAEAB	66A7B0378	M 6 1
6603AAKAA	6603D00374	6843K00173	66B4RC000805	6614AAFAA	6614AAFAB	66A7B0379	M 8 1,25
6603AALAA	6603D00375	6843K00174	66B4RC001005	6614AAGAA	6614AAGAB	66A7B0380	M 10 1,5
6603AAMAA	6603D00376			6614AAHAA	6614AAHAB		M 12 1,75
		7843K00262				76A7B0838	M 14 2
	7603D00377	7843K00265				76A7B0839	M 16 2
7603AABAA	7603D00378	7843K00267				76A7B0840	M 18 2,5
7603AACAA	7603D00379	7843K00269					M 20 2,5
7603AADAA	7603D00380	7843K00258				76A7B0841	M 24 3
							M 27 3
							M 30 3,5
							M 33 3,5
							M 36 4
							M 39 4
							M 42 4,5
							M 45 4,5
							M 48 5
							M 52 5

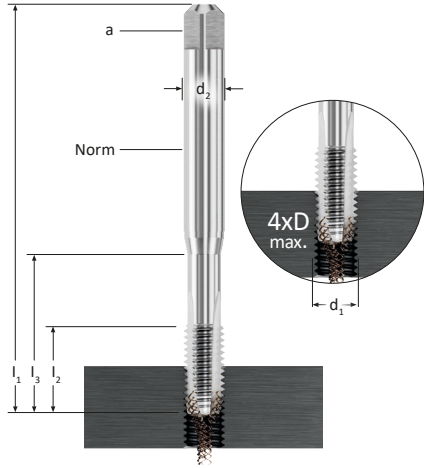

OBERFLÄCHE / SURFACE SURFACE / SUPERFICIE										NITVAP			TIN	
SCHNEIDSTOFF / MATERIAL MATIÈRE / MATERIALE										HSSE			HSSE	
ANSCHNITTFORM / CHAMFER FORM FORME D'ENTRÉE / FORMA D'IMBOCCO										B / 4-5			B / 4-5	
d ₁	P		NORM	l ₁	l ₂	l ₃	d ₂	a	ISO2	ISO3	7G	ISO2	ISO3	
M 1	0,25	0,75	DIN 371	40	5	-	2,5	2,1	6560AC7AA ¹⁾					
M 1,2	0,25	0,95	DIN 371	40	5	-	2,5	2,1	6560AC9AA ¹⁾					
M 1,4	0,3	1,1	DIN 371	40	6	-	2,5	2,1	6560ADAAA ¹⁾					
M 1,6	0,35	1,25	DIN 371	40	6	11	2,5	2,1	6560ABHAB					
M 1,7	0,35	1,35	DIN 371	40	6	11	2,5	2,1	6560ADCAA					
M 1,8	0,35	1,45	DIN 371	40	6	11	2,5	2,1	6560ADDA					
M 2	0,4	1,6	DIN 371	45	7	12	2,8	2,1	6560ABFAC	6560ABIAA	6560A2503	6560ABFAA	6560B0051	
M 2,2	0,45	1,75	DIN 371	45	7	12	2,8	2,1	6560AAIIAA			6560B0050		
M 2,5	0,45	2,05	DIN 371	50	9	14	2,8	2,1	6560AAMAA	6560ADKAA	6560A2505	6560AAMAB	6560B0052	
M 3	0,5	2,5	DIN 371	56	11	18	3,5	2,7	6560AAAAA	6560ABGAA	6560ABEAA	6560AAAAD	6560B0053	
M 3,5	0,6	2,9	DIN 371	56	12	20	4	3	7560AAVAA					
M 4	0,7	3,3	DIN 371	63	13	21	4,5	3,4	6560AANAA	6560ABKAB		6560AANAB	6560B0054	
M 4	0,7	3,3	DIN 376	63	13	-	2,8	2,1	6560AABAA	6560AAUAC	6560AA7AA	6560AABAF	6560B0055	
M 5	0,8	4,2	DIN 371	70	15	25	6	4,9	7560AAWAA			7560B0494		
M 5	0,8	4,2	DIN 376	70	15	-	3,5	2,7	6560AACAA	6560ADMMA	6560AA8AA	6560AACAI	6560B0056	
M 6	1	5,0	DIN 371	80	17	30	6	4,9	7560AAXAA			7560B0495		
M 6	1	5,0	DIN 376	80	17	-	4,5	3,4	6560AADAA	6560AA0AA	6560AA9AA	6560AADAB	6560B0057	
M 7	1	6,0	DIN 371	80	17	30	7	5,5	7560AAYAA			7560B0496		
M 8	1,25	6,8	DIN 371	90	20	35	8	6,2	6560AA5AA					
M 8	1,25	6,8	DIN 376	90	20	-	6	4,9	6560AAEAA	6560AA1AA	6560ABAAA	6560AAEAE	6560B0058	
M 10	1,5	8,5	DIN 371	100	22	39	10	8	7560AAZAA			7560B0497		
M 10	1,5	8,5	DIN 376	100	22	-	7	5,5	6560AAFAC	6560AA2AA	6560AATAA	6560AAFAC	6560B0059	
M 12	1,75	10,2	DIN 371	110	24	44	12	9	7560AA0AA			7560B0498		
M 14	2	12,0	DIN 376	110	26	-	11	9	6560AAGAA					
M 14	2	12,0	DIN 376	110	26	-	11	9	7560AAAAA	7560ABGAB	7560AHBAA	7560AAAAC	7560B0506	
M 16	2	14,0	DIN 376	110	27	-	12	9	7560AABAA			7560A2230		
M 18	2,5	15,5	DIN 376	125	30	-	14	11	7560AACAA	7560AHIAA	7560A2515	7560AACAB	7560B0507	
M 20	2,5	17,5	DIN 376	140	32	-	16	12	7560AG3AA			7560A2232		
M 22	2,5	19,5	DIN 376	140	32	-	18	14,5	7560AAKAA	7560AHKAA		7560A2233	7560B0508	
M 24	3	21,0	DIN 376	160	34	-	18	14,5	7560AA1AA			7560A2234		
M 27	3	24,0	DIN 376	160	36	-	20	16	7560AG4AA			7560A2235		
M 30	3,5	26,5	DIN 376	180	40	-	22	18	7560AG5AA					
M 33	3,5	29,5	DIN 376	180	40	-	25	20	7560AA2AA					
M 36	4	32,0	DIN 376	200	50	-	28	22	7560ACTAB					
M 39	4	35,0	DIN 376	200	50	-	32	24	7560AA3AA					
M 42	4,5	37,5	DIN 376	200	56	-	32	24	7560AG6AA					
M 48	5	43,0	DIN 376	250	65	-	36	29	7560AG7AA					
M 48	5	43,0	DIN 376	250	65	-	36	29	7560AG9AA					

¹⁾ ≤ M1,4 Tol. ISO 1 / ISO 1X

UNI

UNI CNC



TICN	ALTINHD			
HSSE	HSSE-PM			
B / 4-5	B / 4-5			
ISO2	ISO2X	ISO3X	d ₁	P
			M 1	0,25
			M 1,2	0,25
			M 1,4	0,3
			M 1,6	0,35
			M 1,7	0,35
			M 1,8	0,35
	6410K00116		M 2	0,4
			M 2,2	0,45
			M 2,5	0,45
6560AAAAB	6410F0002		M 3	0,5
			M 3	0,5
			M 3,5	0,6
6560AABAC	6410F0003	6410F0010	M 4	0,7
			M 4	0,7
6560AACAC	6410F0004	6410F0012	M 5	0,8
			M 5	0,8
6560AADAE	6410F0005	6410F0014	M 6	1
			M 6	1
			M 7	1
6560AAEAC	6410F0006	6410F0016	M 8	1,25
			M 8	1,25
6560AAFAB	6410F0007	6410F0018	M 10	1,5
			M 10	1,5
			M 12	1,75
	7410F0001	7410F0005	M 12	1,75
	7410F0002		M 14	2
	7410F0003		M 16	2
			M 18	2,5
	7410F0004		M 20	2,5
			M 22	2,5
			M 24	3
			M 27	3
			M 30	3,5
			M 33	3,5
			M 36	4
			M 39	4
			M 42	4,5
			M 48	5

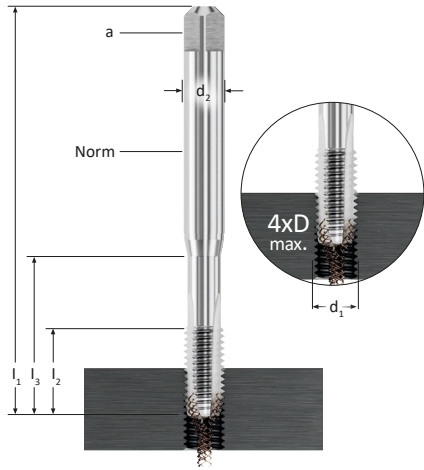

OBERFLÄCHE / SURFACE SURFACE / SUPERFICIE															TIN	TIN
SCHNEIDSTOFF / MATERIAL MATIÈRE / MATERIALE										HSSE					HSSE	HSSE-PM
ANSCHNITTFORM / CHAMFER FORM FORME D'ENTRÉE / FORMA D'IMBOCCO										B / 4-5					B / 4-5	B / 4-5
d ₁	P		NORM	l ₁	l ₂	l ₃	d ₂	a	ISO1	ISO2	ISO2 - LH	ISO3	7G	ISO2	ISO2X	
M 1	0,25	0,75	DIN 371	40	5	-	2,5	2,1	6080A1772							
M 1,1	0,25	0,85	DIN 371	40	5	-	2,5	2,1	6080AABAA							
M 1,2	0,25	0,95	DIN 371	40	5	-	2,5	2,1	6080AACAA							
M 1,4	0,3	1,1	DIN 371	40	6	-	2,5	2,1	6080AADAA							
M 1,6	0,35	1,25	DIN 371	40	6	11	2,5	2,1		6080AAEAA						
M 1,7	0,35	1,35	DIN 371	40	6	11	2,5	2,1		6080AAFAA						
M 1,8	0,35	1,45	DIN 371	40	6	11	2,5	2,1		6080AAGAA						
M 2	0,4	1,6	DIN 371	45	7	12	2,8	2,1	6080A2048	6080AAHAA	6080K00100	6080AAYAA	6080B0042	6080K00105	6160A5296	
M 2,2	0,45	1,75	DIN 371	45	7	12	2,8	2,1		6080AIIAA						
M 2,3	0,4	1,9	DIN 371	45	7	12	2,8	2,1		6080AAJAA						
M 2,5	0,45	2,05	DIN 371	50	9	14	2,8	2,1	6080A2050	6080AAKAA	6080ACMAA	6080A2112	6080B0043	6080S0528577	6160A5297	
M 2,6	0,45	2,15	DIN 371	50	9	14	2,8	2,1		6080AALAA						
M 3	0,5	2,5	DIN 352	40	10	18	3,5	2,7		5080AAFAA						
M 3,5	0,6	2,9	DIN 371	56	11	18	3,5	2,7	6080A2051	6080AAMAA	6080A2162	6080AA3AA	6080B0044	6080D00037	6160A5298	
M 4	0,7	3,3	DIN 371	63	13	21	4,5	3,4		6080AANAA		6080AA4AA				
M 5	0,8	4,2	DIN 352	50	14	25	6	4,9		5080AAHAA						
M 5	0,8	4,2	DIN 371	70	15	25	6	4,9	6080A2054	6080AAPAA	6080A2164	6080AA5AA	6080B0045	6080D00038	6160AAAAA	
M 5	0,8	4,2	DIN 376	70	15	-	3,5	2,7		5080AAIAA						
M 5	0,8	4,2	DIN 376	70	15	-	3,5	2,7		6080AAQAA	6080A2165	6080AA6AA	6080B0046	6080D00039	6160AABAA	
M 6	1	5	DIN 352	56	16	28	6	4,9		7080AALAA						
M 6	1	5	DIN 371	80	17	30	6	4,9	6080A2055	6080AARAA	6080A2166	6080AA7AA	6080B0047	6080D00040	6160AACAA	
M 6	1	5	DIN 376	80	17	-	4,5	3,4		7080AAMAA						
M 7	1	6	DIN 371	80	17	30	7	5,5		6080A1792						
M 7	1	6	DIN 352	63	20	-	6	4,9		5080AAKAA						
M 8	1,25	6,8	DIN 371	90	20	35	8	6,2	6080A2057	6080AATAA	6080A2167	6080AA8AA	6080B0048	6080D00041	6160AADAA	
M 8	1,25	6,8	DIN 376	90	20	-	6	4,9		7080AANAA						
M 10	1,5	8,5	DIN 352	70	22	-	7	5,5		5080AALAA						
M 10	1,5	8,5	DIN 371	100	22	39	10	8	6080A2059	6080AAVAA	6080A2168	6080AA9AA	6080B0049	6080D00042	6160AAEAA	
M 10	1,5	8,5	DIN 376	100	22	-	7	5,5		7080AAPAA						
M 11	1,5	9,5	DIN 376	100	22	-	8	6,2		7080A1800						
M 12	1,75	10,2	DIN 352	75	24	-	9	7		5080AAMAA						
M 12	1,75	10,2	DIN 376	110	24	-	9	7	7080A2060	7080AAQAA	7080A2169	7080A2122	7080B0492	7080D00043	7160AACAA	
M 14	2	12	DIN 376	110	26	-	11	9		7080AARAA						
M 16	2	14	DIN 376	110	27	-	12	9	7080A2062	7080AASAA	7080A2171	7080A2124	7080B0493	7080D00044	7160AADAA	
M 18	2,5	15,5	DIN 376	125	30	-	14	11		7080AATAA						
M 20	2,5	17,5	DIN 376	140	32	-	16	12	7080A2064	7080AAUAA	7080A2173	7080ABAAA	7080F0110	7080D00045	7160A5311	
M 22	2,5	19,5	DIN 376	140	32	-	18	14,5		7080AAVAA						
M 24	3	21	DIN 376	160	34	-	18	14,5	7080A2066	7080AAWAA	7080A2175	7080ABCAA	7080K00175	7080D00046		
M 27	3	24	DIN 376	160	36	-	20	16		7080AAXAA						
M 30	3,5	26,5	DIN 376	180	40	-	22	18		7080AAYAA						
M 33	3,5	29,5	DIN 376	180	40	-	25	20		7080AAZAA						
M 36	4	32	DIN 376	200	50	-	28	22		7080AA0AA						
M 39	4	35	DIN 376	200	50	-	32	24		7080AA1AA						
M 42	4,5	37,5	DIN 376	200	56	-	32	24		7080AA2AA						
M 45	4,5	40,5	DIN 376	220	58	-	36	29		7080AA3AA						
M 48	5	43	DIN 376	250	65	-	36	29		7080AA4AA						
M 52	5	47	DIN 376	250	65	-	40	32		7080AA5AA						

NORIS STABIL

HR

VA

NW

SOFT

TI



ALTiNHD	NIT	ALTiNHD	DLC	DLC	VAP	VAP	TiN	TiN		
HSSE-PM	HSSE	HSSE	HSSE	HSSE	HSSE-PM	HSSE-PM	HSSE-PM	HSSE-PM		
B / 4-5	B / 4-5	B / 4-5	B / 4-5	B / 2-3	B / 4-5	B / 4-5	B / 4-5	B / 4-5		
ISO2X	ISO2	ISO2	ISO2	ISO2	ISO2X	ISO2X	ISO1X	ISO2X	d ₁	P
									M 1	0,25
									M 1,1	0,25
									M 1,2	0,25
									M 1,4	0,3
		6535F0024			6084A2013				M 1,6	0,35
									M 1,7	0,35
6533K00119	6535AABAA	6535F0025	6571K00120	657SB0025	6084A2014		6084A2039		M 1,8	0,35
									M 2	0,4
									M 2,2	0,45
6533K00118	6535AAFAA	6535F0026	6571K00121	657SB0026	6084A2015				M 2,3	0,4
									M 2,5	0,45
									M 2,6	0,45
6533D00352	5535F0002 6535AAGAA 6535AAEAA	6535F0011	6571F0052	657SB0027	6084A2016	6094AAAAA	6084A2040	6084A2024	M 3	0,5
									M 3,5	0,6
6533D00353	5535F0003 6535AAHAA 5535F0004	6535F0012	6571F0053	657SB0028	6084A2018	6094AACAA	6084A2041	6084A2025	M 4	0,7
6533D00354	6535AAIAA	6535F0013	6571F0054	657SB0029	6084A2019	6094AADAA	6084A2042	6084A2026	M 5	0,8
6533D00355	5535F0005 6535AAJAA	6535F0014	6571F0055	657SB0030	6084A2020	6094AAEAA	6084A2043	6084A2027	M 6	1
									M 7	1
6533D00356	5535F0006 6535AAKAA	6535F0015	6571F0056	657SB0031	6084A2021	6094AAFAA	6084A2044	6084A2028	M 8	1,25
6533D00357	5535F0007 6535AALAA	6535F0016	6571F0057	657SB0032	6084A2022	6094AAGAA		6084A2029	M 10	1,5
7533D00358	5535F0008 7535AAFAA	7535F0015	7571F0038	757SB0485	7084A3025			7084A3026	M 12	1,75
7533D00359	7535AAGAA	7535F0016							M 14	2
7533D00360	7535AAHAA	7535F0017	7571F0040	757SB0486					M 16	2
7533D00361	7535A1927								M 18	2,5
7533D00362	7535AAJAA	7535F0018	7571F0041						M 20	2,5
	7535A1928								M 22	2,5
	7535AAKAA								M 24	3
	7535A1929								M 27	3
	7535AALAA								M 30	3,5
									M 33	3,5
									M 36	4
									M 39	4
									M 42	4,5
									M 45	4,5
									M 48	5
									M 52	5

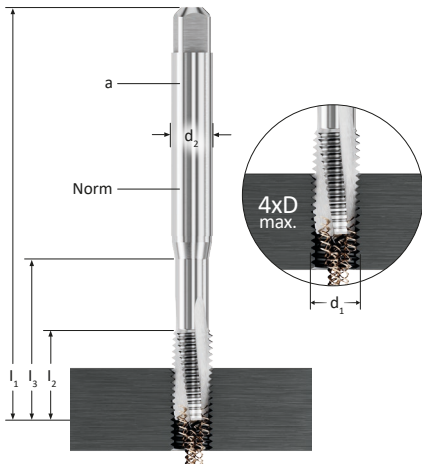

OBERFLÄCHE / SURFACE SURFACE / SUPERFICIE										TICN			TICN		
SCHNEIDSTOFF / MATERIAL MATIÈRE / MATERIALE										HSSE			HSSE-PM		
ANSCHNITTFORM / CHAMFER FORM FORME D'ENTRÉE / FORMA D'IMBOCCO										D / 4-5			D / 4-5		
d ₁	P		NORM	l ₁	l ₂	l ₃	d ₂	a	ISO2X			ISO2X			
M 3	0,5	2,5	DIN 371	56	11	18	3,5	2,7	6504B0096			6507B0076			
M 4	0,7	3,3	DIN 371	63	13	21	4,5	3,4	6504B0097			6507B0077			
M 5	0,8	4,2	DIN 371	70	15	25	6	4,9	6504B0098			6507B0078			
M 6	1	5	DIN 371	80	17	30	6	4,9	6504B0099			6507B0079			
M 8	1,25	6,8	DIN 371	90	20	35	8	6,2	6504B0100			6507B0080			
M 10	1,5	8,5	DIN 371	100	22	39	10	8	6504B0101			6507B0081			
M 12	1,75	10,2	DIN 376	110	24	-	9	7	7504B0537			7507B0529			
M 16	2	14	DIN 376	110	27	-	12	9	7504B0539			7507B0531			
M 20	2,5	17,5	DIN 376	140	32	-	16	12	7504B0541			7507B0532			
M 24	3	21	DIN 376	160	34	-	18	14,5	7504B0543						



SOLUTIONS@NORIS-REIME.DE

Das REIME Team steht Ihnen bei der Lösung Ihrer Zerspanungsaufgabe gerne zur Seite

The REIME team will be happy to solve your threading tasks

L'équipe de REIME se tient à votre disposition pour résoudre vos problèmes de filetage

Il team REIME sarà lieto di risolvere i vostri problemi di filettatura

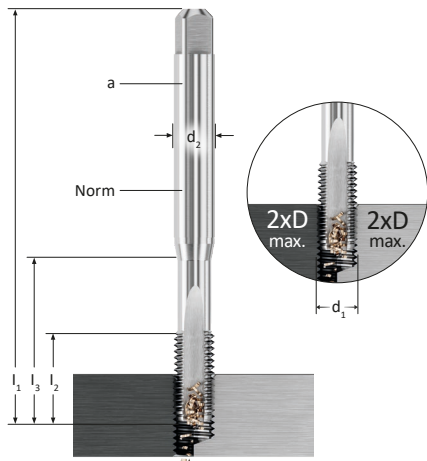

~10xP

OBERFLÄCHE / SURFACE SURFACE / SUPERFICIE										-		NIT		TICN		-	
SCHNEIDSTOFF / MATERIAL MATIÈRE / MATERIALE										HSSE		HSSE		HSSE		HM	
ANSCHNITTFORM / CHAMFER FORM FORME D'ENTRÉE / FORMA D'IMBOCCO										C / 2-3		C / 2-3		C / 2-3		C / 2-3	
d ₁	P		NORM	l ₁	l ₂	l ₃	d ₂	a	ISO2X	ISO2X - LH	ISO2X	ISO2X	ISO2X	ISO2X	ISO2X	ISO2X	
M 1	0,25	0,75	DIN 371	40	5	-	2,5	2,1	6100A1120 ¹⁾								
M 1,1	0,25	0,85	DIN 371	40	5	-	2,5	2,1	6100AABAA ¹⁾								
M 1,2	0,25	0,95	DIN 371	40	5	-	2,5	2,1	6100AACAA ¹⁾								
M 1,4	0,3	1,1	DIN 371	40	6	-	2,5	2,1	6100AADAA ¹⁾								
M 1,6	0,35	1,25	DIN 371	40	6	11	2,5	2,1	6100AAEAA								
M 1,7	0,35	1,35	DIN 371	40	6	11	2,5	2,1	6100AAFAA								
M 1,8	0,35	1,45	DIN 371	40	6	11	2,5	2,1	6100AAGAA								
M 2	0,4	1,6	DIN 371	45	7	12	2,8	2,1	6100AAHAA		6103B0007			6103B0009			
M 2,2	0,45	1,75	DIN 371	45	7	12	2,8	2,1	6100AAIAA								
M 2,3	0,4	1,9	DIN 371	45	7	12	2,8	2,1	6100AAJAA								
M 2,5	0,45	2,05	DIN 371	50	9	14	2,8	2,1	6100AAKAA		6103A1001			6103B0010			
M 2,6	0,45	2,15	DIN 371	50	9	14	2,8	2,1	6100AALAA								
M 3	0,5	2,5	DIN 352	40	10	18	3,5	2,7	5100A1292	5100A1472							
M 3	0,5	2,5	DIN 371	56	11	18	3,5	2,7	6100AAMAA		6103F0002			6103B0011		6300B0312	
M 3,5	0,6	2,9	DIN 371	56	12	20	4	3	6100AANAA		6103A1003			6103B0012			
M 4	0,7	3,3	DIN 352	45	12	22	4,5	3,4	5100A1294	5100A1474							
M 4	0,7	3,3	DIN 371	63	13	21	4,5	3,4	6100AAPAA		6103F0003			6103A1501		6300B0313	
M 4	0,7	3,3	DIN 376	63	13	-	2,8	2,1	7100AADAA								
M 5	0,8	4,2	DIN 352	50	14	25	6	4,9	5100A1296	5100A1475							
M 5	0,8	4,2	DIN 371	70	15	25	6	4,9	6100AAQAA		6103F0004	6813F0001	6103A1502	6813F0005	6300B0314		
M 5	0,8	4,2	DIN 376	70	15	-	3,5	2,7	7100AAEAA								
M 6	1	5	DIN 352	56	16	28	6	4,9	5100A1297	5100A1476							
M 6	1	5	DIN 371	80	17	30	6	4,9	6100AARAA		6103F0001	6813F0002	6103A1503	6813F0021	6300B0315		
M 6	1	5	DIN 376	80	17	-	4,5	3,4	7100AAFAA								
M 7	1	6	DIN 371	80	17	30	7	5,5	6100AASAA		6103B0008			6103B0013			
M 7	1	6	DIN 376	80	17	-	5,5	4,3	7100A1141								
M 8	1,25	6,8	DIN 352	63	20	-	6	4,9	5100A1299	5100A1477							
M 8	1,25	6,8	DIN 371	90	20	35	8	6,2	6100AATAA		6103F0005	6813F0003	6103A1504	6813E5039	6300B0316		
M 8	1,25	6,8	DIN 376	90	20	-	6	4,9	7100AAGAA								
M 9	1,25	7,8	DIN 371	90	20	35	9	7	6100A1144								
M 9	1,25	7,8	DIN 376	90	20	-	7	5,5	7100A1145								
M 10	1,5	8,5	DIN 352	70	22	-	7	5,5	5100A1301	5100A1478							
M 10	1,5	8,5	DIN 371	100	22	39	10	8	6100AAVAA		6103F0006	6813F0004	6103A1505	6813E5040	6300B0317		
M 10	1,5	8,5	DIN 376	100	22	-	7	5,5	7100AAHAA								
M 11	1,5	9,5	DIN 376	100	22	-	8	6,2	7100A1148								
M 12	1,75	10,2	DIN 352	75	24	-	9	7	5100A1302	5100A1479							
M 12	1,75	10,2	DIN 376	110	24	-	9	7	7100AAIAA		7103AAWAA	7813F0003	7103A1506	7813E5042	7300B0718		
M 14	2	12	DIN 371	110	24	44	14	11									
M 14	2	12	DIN 376	110	26	-	11	9	7100AAJAA		7103A1010	7813K00257	7103B0437	7813F0006			
M 16	2	14	DIN 371	110	24	44	16	12									
M 16	2	14	DIN 376	110	27	-	12	9	7100AAKAA		7103F0011	7813F0004	7103A1507	7813E5044	7300B0720		
M 18	2,5	15,5	DIN 376	125	30	-	14	11	7100AALAA		7103A1012		7103B0438		7300B0721		
M 20	2,5	17,5	DIN 376	140	32	-	16	12	7100AAMAA		7103A1013	7813A5130	7103A1508	7813E5045	7300B0722		
M 22	2,5	19,5	DIN 376	140	32	-	18	14,5	7100AANAA						7300B0723		
M 24	3	21	DIN 376	160	34	-	18	14,5	7100AAPAA		7103A1015		7103B0439		7300B0724		
M 27	3	24	DIN 376	160	36	-	20	16	7100AAQAA								
M 30	3,5	26,5	DIN 376	180	40	-	22	18	7100AARAA								
M 33	3,5	29,5	DIN 376	180	40	-	25	20	7100AASAA								
M 36	4	32	DIN 376	200	50	-	28	22	7100AATAA								
M 39	4	35	DIN 376	200	50	-	32	24	7100AAUAA								
M 42	4,5	37,5	DIN 376	200	56	-	32	24	7100AAVAA								
M 45	4,5	40,5	DIN 376	220	58	-	36	29	7100A1163								
M 48	5	43	DIN 376	250	65	-	36	29	7100A1164								
M 52	5	47	DIN 376	250	65	-	40	32	7100A1165								

¹⁾ ≤ M1,4 Tol. ISO 1 / ISO 1X

NORIS TWIN

GG

GGV

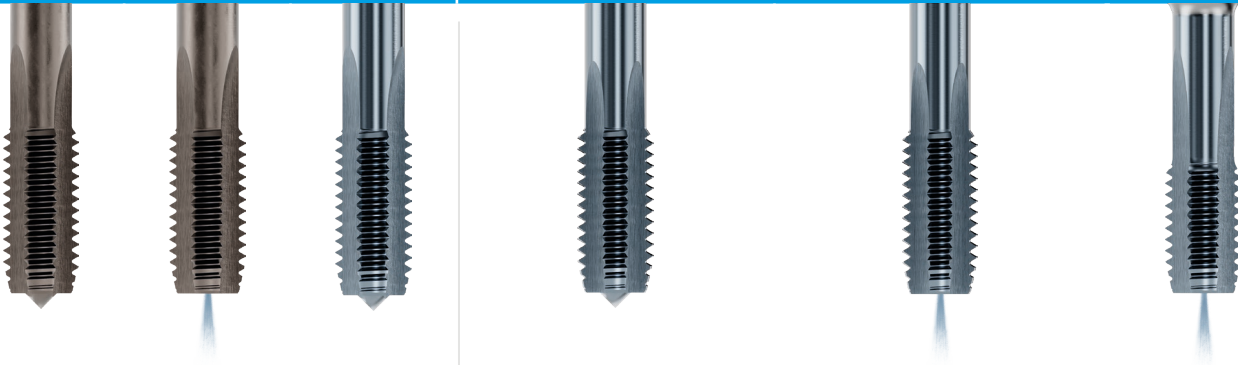

NIT		TICN	TICN		TICN		TICN	
HSSE		HSSE	HSSE-PM		HSSE-PM		HM	
C / 2-3		C / 2-3	C / 2-3	E / 1,5-2	C / 2-3	E / 1,5-2	E / 1,5-2	
ISO2X	ISO2X	ISO2X	ISO2X	ISO2X	ISO2X	ISO2X	ISO2X	d ₁ P
								M 1 0,25
								M 1,1 0,25
								M 1,2 0,25
								M 1,4 0,3
								M 1,6 0,35
								M 1,7 0,35
								M 1,8 0,35
6200AADAA								M 2 0,4
								M 2,2 0,45
6200AEAA								M 2,3 0,4
								M 2,5 0,45
								M 2,6 0,45
6200AAFAA		6200S0550443						M 3 0,5
6200AAGAA								M 3,5 0,6
6200AAHAA		6200B0014					630GRE000405	M 4 0,7
6200AAIAA	6820AAAAA	6200B0015	620GF0004	620GF0009	682GF0002	682GF0007	630GRE000505	M 5 0,8
6200AAJAA	6820AABAA	6200B0016	620GF0005	620GF0010	682GF0003	682GF0008	630GRE000605	M 6 1
6200A1384		6200K00115	620GF0006	620GF0011	682GF0004	682GF0009		M 7 1
6200AAKAA	6820AACAA	6200B0017	620GF0007	620GF0012	682GF0005	682GF0010	630GRE000805	M 8 1,25
								M 9 1,25
6200AALAA	6820AADAA	6200B0018	620GF0008	620GF0013	682GF0006	682GF0011	630GRE001005	M 10 1,5
7200AAHAA	7820AAAAA	7200B0458	720GF0001	720GF0007	782GF0002	782GF0008	730GRE001125	M 12 1,75
7200AAIAA	7820AABAA	7200B0459						M 14 2
7200AAJAA	7820AACAA	7200B0460	720GF0002	720GF0001	782GF0003	782GF0001	730GRE001165	M 16 2
7200AAKAA		7200B0461						M 18 2,5
7200AALAA	7820AADAA	7200B0462		720GK00336	782GK00338	782GK00340		M 20 2,5
7200AAMAA		7200B0463						M 22 2,5
7200AANAA		7200B0464						M 24 3
7200AAPAA								M 27 3
7200AAQAA								M 30 3,5
								M 33 3,5
								M 36 4
								M 39 4
								M 42 4,5
								M 45 4,5
								M 48 5
								M 52 5

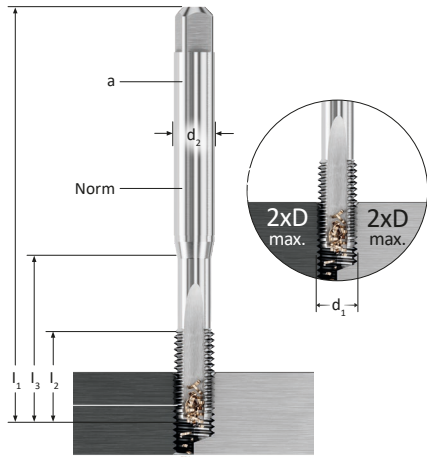

OBERFLÄCHE / SURFACE SURFACE / SUPERFICIE										-	-	OSM	TICN	ALTIN
SCHNEIDSTOFF / MATERIAL MATIÈRE / MATERIALE										HSSE	HSSE-PM	HSSE	HSSE-PM	HM
ANSCHNITTFORM / CHAMFER FORM FORME D'ENTRÉE / FORMA D'IMBOCCO										C / 2-3	C / 2-3	C / 2-3	C / 2-3	D / 4-5
d ₁	P		NORM	l ₁	l ₂	l ₃	d ₂	a	ISO2X	ISO2X	ISO2X	ISO2X	ISO2X	
M 2	0,4	1,6	DIN 371	45	7	12	2,8	2,1	6250A1461					
M 2,5	0,45	2,05	DIN 371	50	9	14	2,8	2,1	6250A1463					
			DIN 352	40	10	18	3,5	2,7	5250AAFAA					
M 3	0,5	2,5	DIN 371	56	11	18	3,5	2,7	6250A1464	6106AAAAA	610AB0001			
			DIN 371	63	6	18	4,5	3,4					6260AAAAA	
M 3,5	0,6	2,9	DIN 371	56	12	20	4	3	6250A1465					
			DIN 352	45	12	22	4,5	3,4	5250AAHAA					
M 4	0,7	3,3	DIN 371	63	13	21	4,5	3,4	6250A1466	6106AABAA	610AB0002		6260AABAA	
			DIN 352	50	14	25	6	4,9	5250AAIAA					
M 5	0,8	4,2	DIN 371	70	15	25	6	4,9	6250A1467	6106AACAA	610AB0003		6260AACAA	
			DIN 352	56	16	28	6	4,9	5250AAJAA					
M 6	1	5	DIN 371	80	17	30	6	4,9	6250A1468	6106AADAA	610AB0004	610HF0003	6260AADAA	
			DIN 352	63	20	-	6	4,9	5250AAKAA					
M 8	1,25	6,8	DIN 371	90	20	35	8	6,2	6250A1469	6106AAEAA	610AB0005	610HF0001	6260AAEAA	
			DIN 352	70	22	-	7	5,5	5250AALAA					
M 10	1,5	8,5	DIN 371	100	22	39	10	8	6250A1470	6106AAFAA	610AB0006	610HF0002	6260AAFAA	
			DIN 371	110	24	44	12	9					6260F0005	
M 12	1,75	10,2	DIN 376	110	24	-	9	7		7106AABAA		710HF0001		
			DIN 371	110	24	44	16	12					6260F0004	
M 14	2	12	DIN 376	110	27	-	12	9				710HF0003	6260F0003	
			DIN 371	110	24	44	16	12						
M 16	2	14	DIN 376	125	30	-	14	11						
			DIN 371	110	24	44	16	12						
M 18	2,5	17,5	DIN 376	140	32	-	16	12		7106AAEAA				
			DIN 371	110	24	44	16	12						
M 20	2,5	17,5	DIN 376	140	32	-	18	14,5						
			DIN 371	110	24	44	16	12						
M 22	2,5	19,5	DIN 376	160	34	-	18	14,5						
			DIN 371	110	24	44	16	12						
M 24	3	21	DIN 376	160	34	-	18	14,5		7106AAFAA				



SOLUTIONS@NORIS-REIME.DE

Das REIME Team steht Ihnen bei der Lösung Ihrer Zerspanungsaufgabe gerne zur Seite

The REIME team will be happy to solve your threading tasks

L'équipe de REIME se tient à votre disposition pour résoudre vos problèmes de filetage

Il team REIME sarà lieto di risolvere i vostri problemi di filettatura

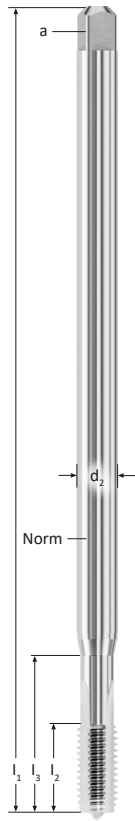

EL

EL

EL

EL

EL

EL

OBERFLÄCHE / SURFACE SURFACE / SUPERFICIE										NITVAP		-		NIT		-		VAP		-	
SCHNEIDSTOFF / MATERIAL MATIÈRE / MATERIALE										HSSE		HSSE		HSSE		HSSE		HSSE		HSSE	
ANSCHNITTFORM / CHAMFER FORM FORME D'ENTRÉE / FORMA D'IMBOCCO										B / 4-5		B / 4-5		C / 2-3		E / 1,5-2		C / 2-3		C / 2-3	
d ₁	P		NORM	l ₁	l ₂	l ₃	d ₂	a	ISO2	ISO2	ISO2X	ISO2	ISO2	ISO2	ISO2	ISO2					
M 3	0,5	2,5	-	100	11	18	3,5	2,7	6580AAAAA	6190B0325	6183A5187	6710AAAAA	6672AAAAA	6670B0330							
M 4	0,7	3,3	-	125	13	21	4,5	3,4	6580AABAA	6190B0326	6183A5188	6710AABAA	6672AABAA	6670B0331							
M 5	0,8	4,2	-	140	15	25	6	4,9	6580AACAA	6190B0327	6183A5189	6710AACAA	6672AACAA	6670B0332							
M 6	1	5	-	160	17	30	6	4,9	6580AADAA	6190B0328	6183A5190	6710AADAA	6672AADAA	6670B0333							
			-	160	17	-	4,5	3,4	7580A5217	7190B0744	7183A5191	7710AAAAA	7672A5257	7670B0752							
M 8	1,25	6,8	-	180	20	35	8	6,2	6580AAEAA	6190B0329	6183A5192	6710AAEAA	6672AAEAA	6670B0334							
			-	180	20	-	6	4,9	7580A5219	7190B0745	7183A5193	7710AABAA	7672A5259	7670B0753							
M 10	1,5	8,5	-	200	22	-	7	5,5	7580A5220	7190B0746	7183A5194	7710AACAA	7672AAAAA	7670B0754							
M 12	1,75	10,2	-	224	24	-	9	7	7580ADAAA	7190B0747	7183A5195	7710AADAA	7672AABAA	7670B0755							
M 14	2	12	-	224	26	-	11	9	7580A5223	7190B0748	7183A5196	7710AAEAA	7672E3114	7670B0756							
M 16	2	14	-	224	27	-	12	9	7580AAFAA	7190B0749	7183A5197	7710AAFAA	7672AACAA	7670B0757							
M 18	2,5	15,5	-	250	30	-	14	11	7580A5225	7190B0750	7183A5198	7710A5238	7672A5264	7670B0758							
M 20	2,5	17,5	-	280	32	-	16	12	7580A5226	7190B0751	7183A5199	7710AAGAA	7672E0255	7670B0759							

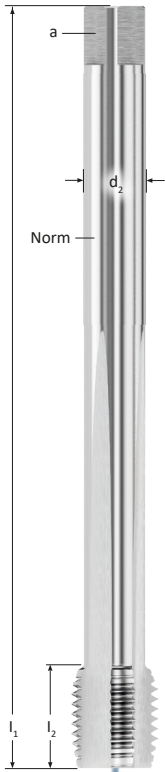

CNC ELF



CNC ELF

OBERFLÄCHE / SURFACE SURFACE / SUPERFICIE											TICN	TIN
SCHNEIDSTOFF / MATERIAL MATIÈRE / MATERIALE											HSSE	HSSE
ANSCHNITTFORM / CHAMFER FORM FORME D'ENTRÉE / FORMA D'IMBOCCO											C / 2-3	C / 2-3
S	d ₁	P		NORM	l ₁	l ₂	l ₃	d ₂	a	ISO2X	ISO2X	
M 20	2,5	17,5		DIN 376 LF	190	25	-	16	12	981CK00363	984CK00375	
M 22	2,5	19,5		DIN 376 LF	230	27	-	18	14,5	981CK00364	984CK00376	
M 24	3	21		DIN 376 LF	240	30	-	18	14,5	981CS0561623	984CK00377	
M 27	3	24		DIN 376 LF	250	30	-	20	16	981CK00367	984CK00379	
M 30	3,5	26,5		DIN 376 LF	270	35	-	22	18	981CS0561664	984CK00380	
M 33	3,5	29,5		DIN 376 LF	290	35	-	25	20	981CK00370	984CK00382	
M 36	4	32		DIN 376 LF	310	40	-	28	22	981CK00371	984CK00383	
M 42	4,5	37,5		DIN 376 LF	340	45	-	32	24	981CK00373	984CK00385	
M 45	4,5	40,5		DIN 376 LF	360	45	-	36	29	981CK00374	984CK00386	

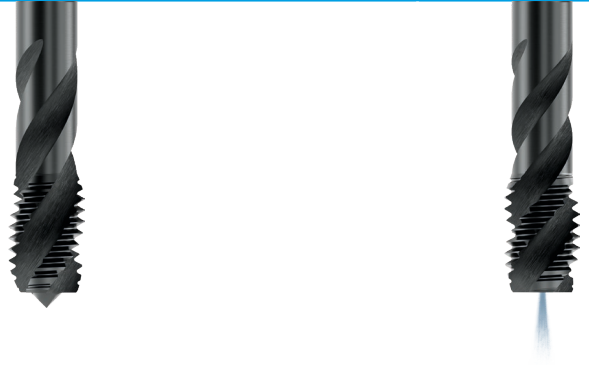
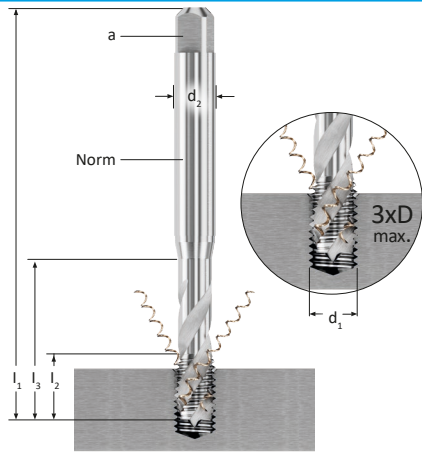

OBERFLÄCHE / SURFACE SURFACE / SUPERFICIE										VAP			
SCHNEIDSTOFF / MATERIAL MATIÈRE / MATERIALE										HSSE			
ANSCHNITTFORM / CHAMFER FORM FORME D'ENTRÉE / FORMA D'IMBOCCO										C / 2-3		E / 1,5-2	
d ₁	x	P		NORM	l ₁	l ₂	l ₃	d ₂	a	ISO2	ISO2	ISO3	ISO2
MF 4	x	0,5	3,5	DIN 371	63	5	21	4,5	3,4	6642A5618		6642A4440	
MF 5	x	0,5	4,5	DIN 371	70	5	25	6	4,9	6642F0043		6642A4441	
MF 6	x	0,5	5,5	DIN 371	80	5	30	6	4,9	6642A5620			
MF 6	x	0,75	5,2	DIN 371	80	8	30	6	4,9	6642A5621		6642A4443	
				DIN 374	80	8	-	4,5	3,4	7642ABNAA			
MF 8	x	0,75	7,2	DIN 374	80	8	-	6	4,9	7642ABPAA			
MF 8	x	1	7	DIN 374	90	10	-	6	4,9	7642ABQAA	7642ABQAP	7642A4445	
MF 10	x	0,75	9,2	DIN 374	90	10	-	7	5,5	7642A5625			
MF 10	x	1	9	DIN 371	90	10	35	10	8				
				DIN 374	90	10	-	7	5,5	7642ABRAA	7642ABRAR	7642A4446	
MF 10	x	1,25	8,8	DIN 371	100	16	39	10	8				
				DIN 374	100	16	-	7	5,5	7642ADUAA			
MF 12	x	1	11	DIN 374	100	11	-	9	7	7642ABSAA		7642A4447	
MF 12	x	1,25	10,8	DIN 374	100	15	-	9	7	7642ADVAA			
MF 12	x	1,5	10,5	DIN 374	100	15	-	9	7	7642ABTAA	7642AY9AB	7642A4448	7852A5065
MF 14	x	1,5	12,5	DIN 374	100	15	-	11	9	7642ABUAA	7642ABUAW	7642A4449	7852A5066
MF 16	x	1,5	14,5	DIN 374	100	15	-	12	9	7642ABVAA	7642ABVAS	7642A4450	7852A5067
MF 18	x	1,5	16,5	DIN 374	110	17	-	14	11	7642ABWAA		7642A4451	
MF 20	x	1,5	18,5	DIN 374	125	17	-	16	12	7642ABXAA		7642A4452	7852A5068
MF 22	x	1,5	20,5	DIN 374	125	17	-	18	14,5	7642ABYAA			
MF 24	x	1,5	22,5	DIN 374	140	20	-	18	14,5	7642ABZAA			
MF 26	x	1,5	24,5	DIN 374	140	20	-	18	14,5	7642AB0AA			
MF 28	x	1,5	26,5	DIN 374	140	20	-	20	16	7642AB2AA			
MF 30	x	1,5	28,5	DIN 374	150	22	-	22	18	7642AB3AA			



TIN		ALTiNHD			
HSSE		HSSE			
C / 2-3	E / 1,5-2	E / 1,5-2			
ISO2	ISO2	ISO2	ISO3	7G	d ₁ x P
6642B0181					MF 4 x 0,5
6642B0182		6470F0019			MF 5 x 0,5
6642B0183		6470F0020			MF 6 x 0,5
6642B0184		6470F0021			MF 6 x 0,75
					MF 6 x 0,75
		7470F0035	7470F0034		MF 8 x 0,75
7642ABQAB	7642ABQAQ	7470F0038	7470F0036	7470F0037	MF 8 x 1
					MF 10 x 0,75
6642B0186					MF 10 x 1
7642ABRAB	7642ABRAT	7470F0041	7470F0040	7470F0039	MF 10 x 1
6642B0187					MF 10 x 1,25
					MF 10 x 1,25
7642A3832	7642A4483	7470F0042	7470F0043		MF 12 x 1
					MF 12 x 1,25
7642ABTAB	7642AY9AC	7470F0045	7470F0046	7470F0044	MF 12 x 1,5
7642ABUAB	7642ABUAX	7470F0048	7470F0047	7470F0049	MF 14 x 1,5
7642ABVAB	7642ABVAT	7470F0051	7470F0052	7470F0050	MF 16 x 1,5
7642A3836	7642A4487	7470F0053			MF 18 x 1,5
7642A3837	7642A4488	7470F0054		7470F0055	MF 20 x 1,5
					MF 22 x 1,5
					MF 24 x 1,5
					MF 26 x 1,5
					MF 28 x 1,5
					MF 30 x 1,5

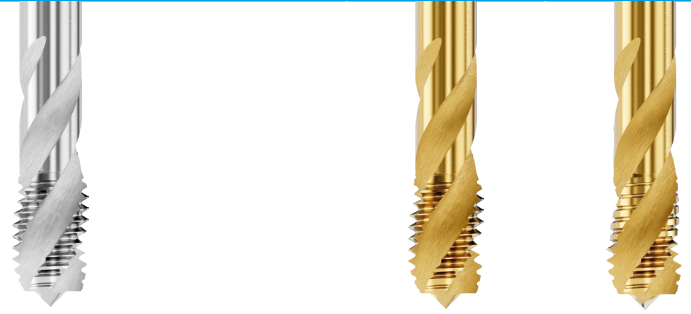
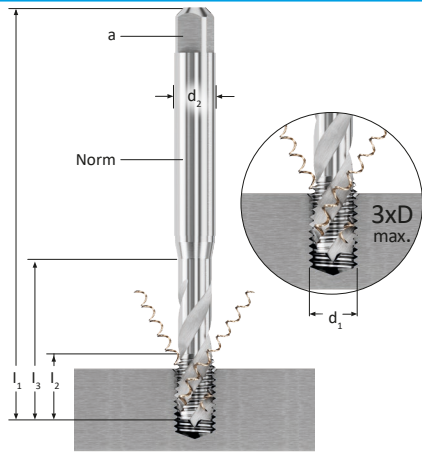

TS

OBERFLÄCHE / SURFACE SURFACE / SUPERFICIE										-			TIN		
SCHNEIDSTOFF / MATERIAL MATIÈRE / MATERIALE										HSSE			HSSE		HSSE-PM
ANSCHNITTFORM / CHAMFER FORM FORME D'ENTRÉE / FORMA D'IMBOCCO										C / 2-3			C / 2-3		C / 2-3
d_1	x	P	NORM	l_1	l_2	l_3	d_2	a	ISO1	ISO2 - LH	ISO2	ISO2	ISO2		
MF 2,5	x	0,35	2,15	DIN 371	50	5	12	2,8	2,1			6640A3507			
MF 2,6	x	0,35	2,25	DIN 371	50	5	12	2,8	2,1			6640B0179			
MF 3	x	0,35	2,65	DIN 371	56	5	18	3,5	2,7			6640A3508			
MF 3,5	x	0,35	3,15	DIN 371	56	5	20	4	3			6640A3509			
MF 4	x	0,5	3,5	DIN 371	63	5	21	4,5	3,4	6640A3709		6640A3510			
MF 5	x	0,5	4,5	DIN 371	70	5	25	6	4,9	6640A3710		6640A3511			
MF 6	x	0,5	5,5	DIN 371	80	5	30	6	4,9			6640A3512			
MF 6	x	0,75	5,2	DIN 371	80	8	30	6	4,9	6640A3712		6640A3513			
MF 7	x	0,75	6,2	DIN 371	80	8	30	7	5,5			7640AAZAA	7640D00179		
MF 8	x	0,75	7,2	DIN 371	80	8	30	8	6,2			6640A3515			
MF 8	x	1	7	DIN 371	90	10	35	8	6,2			6640A3517			
MF 8	x	1	7	DIN 374	80	8	-	6	4,9			7640AA1AA	7640D00180		
MF 9	x	1	8	DIN 371	90	10	35	9	7	7640A3714	7640A3806	6640A3518			
MF 9	x	1	8	DIN 374	90	10	-	7	5,5			6640A3521			
MF 10	x	0,75	9,2	DIN 371	90	8	35	10	8			7640A3522			
MF 10	x	0,75	9,2	DIN 374	90	8	-	7	5,5			6640A3523			
MF 10	x	1	9	DIN 371	90	10	35	10	8			7640A3528	7640D00182		
MF 10	x	1	9	DIN 374	90	10	-	7	5,5	7640A3715	7640A3807	6640A3524			
MF 10	x	1,25	8,8	DIN 371	100	16	39	10	8			7640AA3AA	7640D00183	7880A4536	
MF 10	x	1,25	8,8	DIN 374	100	16	-	7	5,5			6640A3525			
MF 11	x	1	10	DIN 371	90	11	-	8	6,2			7640A3527	7640D00184	7880F0010	
MF 11	x	1	10	DIN 374	90	11	-	9	7	7640A3716	7640A3808	7640A3529			
MF 12	x	1	11	DIN 371	100	11	-	9	7			7640AA4AA	7640D00185		
MF 12	x	1,25	10,8	DIN 374	100	15	-	9	7			7640A3531	7640D00186	7880F0008	
MF 12	x	1,5	10,5	DIN 371	100	15	-	9	7	7640A3717	7640A3809	7640AA5AA	7640D00187	7880A4537	
MF 14	x	1	13	DIN 371	100	11	-	11	9			7640A3535	7640D00188		
MF 14	x	1,25	12,8	DIN 374	100	15	-	11	9			7640A3536	7640D00189		
MF 14	x	1,5	12,5	DIN 371	100	15	-	11	9	7640A3718	7640A3810	7640AA6AA	7640D00190	7880A4538	
MF 16	x	1	15	DIN 371	100	12	-	12	9			7640A3540	7640D00191		
MF 16	x	1,5	14,5	DIN 374	100	15	-	12	9	7640A3719	7640A3811	7640AA7AA	7640D00192	7880A4539	
MF 18	x	1	17	DIN 371	110	13	-	14	11			7640A3541			
MF 18	x	1,5	16,5	DIN 374	110	17	-	14	11	7640A3720	7640A3812	7640AA8AA		7880B0800	
MF 18	x	2	16	DIN 371	125	20	-	14	11			7640A3543			
MF 20	x	1	19	DIN 371	125	14	-	16	12			7640A3544	7640D00193		
MF 20	x	1,5	18,5	DIN 374	125	17	-	16	12	7640A3721	7640A3813	7640AA9AA	7640D00194	7880B0801	
MF 20	x	2	18	DIN 371	140	20	-	16	12			7640A3546	7640D00195		
MF 22	x	1	21	DIN 371	125	14	-	18	14,5			7640A3548			
MF 22	x	1,5	20,5	DIN 374	125	17	-	18	14,5			7640ABAAA	7640D00196		
MF 22	x	2	20	DIN 371	140	20	-	18	14,5			7640A3549	7640D00197		
MF 24	x	1	23	DIN 371	140	15	-	18	14,5			7640A3552			
MF 24	x	1,5	22,5	DIN 374	140	20	-	18	14,5			7640ABBAA	7640D00198		
MF 24	x	2	22	DIN 371	140	20	-	18	14,5			7640A3551	7640D00199		
MF 25	x	1,5	23,5	DIN 374	140	20	-	18	14,5			7640A3553			
MF 26	x	1,5	24,5	DIN 371	140	20	-	18	14,5			7640ABCAA	7640D00200		
MF 27	x	1,5	25,5	DIN 374	140	20	-	20	16			7640A3555			
MF 27	x	2	25	DIN 371	140	20	-	20	16			7640A3556	7640D00201		
MF 28	x	1,5	26,5	DIN 374	140	20	-	20	16			7640ABDAA			
MF 28	x	2	26	DIN 371	140	20	-	20	16			7640A3558			
MF 30	x	1,5	28,5	DIN 374	150	22	-	22	18			7640ABEAA	7640D00202		
MF 30	x	2	28	DIN 371	150	22	-	22	18			7640A3559	7640D00203		

* weitere Abmessungen siehe Seite 40 | further dimensions see page 40 | pour plus de dimensions, voir page 40 | per le altre dimensioni andare a pagina 40

NORIS SALOREX
VR

HR

VA

NW

S

-	ALTiNHd		TiBLU		VAP	ALTiNHd	DLC	
HSSE-PM	HSSE-PM		HSSE-PM		HSSE	HSSE	HSSE	
C / 2-3	C / 2-3		C / 2-3	E / 1,5-2	E / 1,5-2	E / 1,5-2	C / 2-3	
ISO2	ISO2	ISO2	ISO2X	ISO2X	ISO2	ISO2	ISO2	d ₁ x P
								MF 2,5 x 0,35
								MF 2,6 x 0,35
								MF 3 x 0,35
								MF 3,5 x 0,35
						6645A4220		MF 4 x 0,5
						6645F0014		MF 5 x 0,5
						6645F0015		MF 6 x 0,5
			7655K00192	7655K00232		6645F0016		MF 6 x 0,75
								MF 7 x 0,75
						7645F0016		MF 8 x 0,75
7643F0201	7643F0177	7853F0012	7655K00193	7655K00233	7645AAVAA	7645F0017	7641F0093	MF 8 x 1
								MF 9 x 1
								MF 10 x 0,75
7643F0202	7643F0178	7853F0013	7655K00194	7655K00234	7645ABMAA	7645F0018	7641F0094	MF 10 x 1
7643F0203	7643F0179	7853F0014	7655K00195	7655K00235			7641F0105	MF 10 x 1,25
			7655K00198	7655K00238	7645AAMAA	7645F0019	7641F0095	MF 11 x 1
7643F0204	7643F0180	7853F0015	7655K00199	7655K00239	7645AASAA	7645F0020	7641F0106	MF 12 x 1
7643F0205	7643F0181	7853F0016	7655K00200	7655K00240			7641F0107	MF 12 x 1,25
							7641F0108	MF 12 x 1,5
7643F0206	7643F0182	7853F0017	7655K00202	7655K00242	7645AACAA	7645F0021	7641F0109	MF 14 x 1
							7641F0109	MF 14 x 1,25
7643F0207	7643F0183	7853F0018	7655K00205	7655K00245	7645AAKAA	7645F0022	7641F0098	MF 14 x 1,5
			7655K00206	7655K00246				MF 16 x 1
								MF 18 x 1
								MF 18 x 1,5
								MF 18 x 2
			7655K00209	7655K00249	7645AAHAA	7645F0024		MF 20 x 1
								MF 20 x 1,5
								MF 20 x 2
			7655K00210	7655K00250			7645B0614	MF 22 x 1
								MF 22 x 1,5
								MF 22 x 2
			7655K00213	7655K00253			7645B0615	MF 24 x 1
								MF 24 x 1,5
								MF 24 x 2
					7645AAQAA			MF 24 x 1,5
								MF 25 x 1,5
								MF 26 x 1,5
								MF 27 x 1,5
					7645AA1AA			MF 27 x 2
								MF 28 x 1,5
								MF 28 x 2
					7645AAQAA			MF 30 x 1,5
								MF 30 x 2

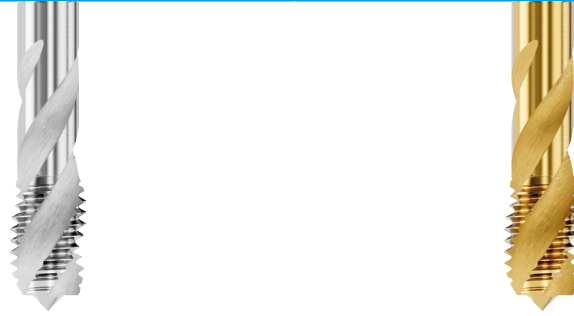
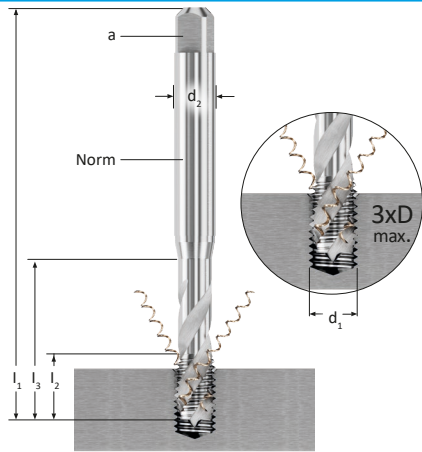

OBERFLÄCHE / SURFACE SURFACE / SUPERFICIE										-			TIN		
SCHNEIDSTOFF / MATERIAL MATIÈRE / MATERIALE										HSSE			HSSE		
ANSCHNITTFORM / CHAMFER FORM FORME D'ENTRÉE / FORMA D'IMBOCCO										C / 2-3			C / 2-3		
d_1	x	P		NORM	l_1	l_2	l_3	d_2	a	ISO2			ISO2		
MF 32	x	1,5	30,5	DIN 374	150	22	-	22	18	7640A3561					
MF 33	x	1,5	31,5	DIN 374	160	24	-	25	20	7640A3563					
MF 33	x	2	31	DIN 374	160	24	-	25	20	7640A3562			7640D00204		
MF 34	x	1,5	32,5	DIN 374	170	24	-	28	22	7640A3564					
MF 35	x	1,5	33,5	DIN 374	170	24	-	28	22	7640A3565					
MF 36	x	1,5	34,5	DIN 374	170	24	-	28	22	7640A3566			7640D00205		
MF 36	x	2	34	DIN 374	170	24	-	28	22	7640A3567			7640D00206		
MF 36	x	3	33	DIN 374	200	30	-	28	22	7640A3568			7640D00207		
MF 38	x	1,5	36,5	DIN 374	170	24	-	28	22	7640A3569					
MF 40	x	1,5	38,5	DIN 374	170	25	-	32	24	7640A3570			7640D00208		
MF 42	x	1,5	40,5	DIN 374	170	25	-	32	24	7640A3572			7640D00209		
MF 42	x	2	40	DIN 374	170	25	-	32	24	7640A3573			7640D00210		
MF 42	x	3	39	DIN 374	200	30	-	32	24	7640A3571			7640D00211		
MF 45	x	1,5	43,5	DIN 374	180	27	-	36	29	7640A3574			7640D00212		
MF 48	x	1,5	46,5	DIN 374	190	27	-	36	29	7640A3575			7640D00213		
MF 48	x	2	46	DIN 374	190	27	-	36	29	7640A3576			7640D00214		
MF 48	x	3	45	DIN 374	225	33	-	36	29	7640A3577			7640D00215		
MF 50	x	1,5	48,5	DIN 374	190	27	-	36	29	7640A3578					
MF 52	x	1,5	50,5	DIN 374	190	27	-	40	32	7640A3579					
MF 52	x	2	50	DIN 374	190	27	-	40	32	7640A3580					



SOLUTIONS@NORIS-REIME.DE

Das REIME Team steht Ihnen bei der Lösung Ihrer Zerspanungsaufgabe gerne zur Seite

The REIME team will be happy to solve your threading tasks

L'équipe de REIME se tient à votre disposition pour résoudre vos problèmes de filetage

Il team REIME sarà lieto di risolvere i vostri problemi di filettatura

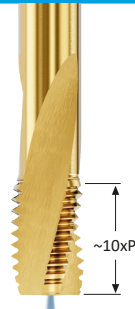
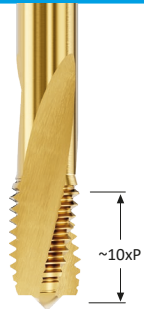
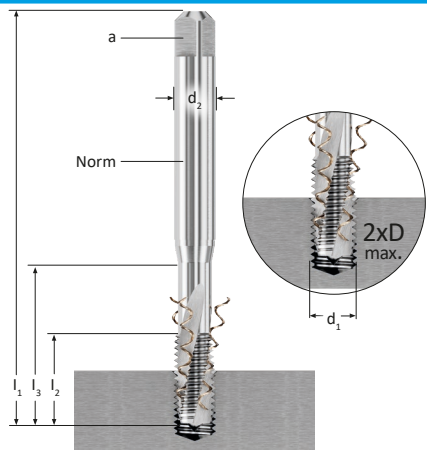

OBERFLÄCHE / SURFACE SURFACE / SUPERFICIE									-			TIN		ALTiNHD	
SCHNEIDSTOFF / MATERIAL MATIÈRE / MATERIALE									HSSE			HSSE		HSSE-PM	
ANSCHNITTFORM / CHAMFER FORM FORME D'ENTRÉE / FORMA D'IMBOCCO									C / 2-3			C / 2-3		C / 2-3	
d ₁	P		NORM	l ₁	l ₂	l ₃	d ₂	a	ISO2	ISO2X	ISO2X	ISO2	ISO2		
MF 6	x 0,75	5,2	DIN 374	80	13	-	4,5	3,4	7600AC4AA						
MF 8	x 0,75	7,2	DIN 374	80	14	-	6	4,9	7600AC7AA						
MF 8	x 1	7	DIN 374	90	17	-	6	4,9	7600AC8AA	760CB0547	784CB0696	7603D00381	7843K00259		
MF 9	x 1	8	DIN 374	90	17	-	7	5,5	7600AC9AA						
MF 10	x 0,75	9,2	DIN 374	90	18	-	7	5,5	7600ADAAA						
MF 10	x 1	9	DIN 374	90	18	-	7	5,5	7600ADBAA	760CB0548	784CB0697	7603D00382	7843K00260		
MF 10	x 1,25	8,8	DIN 374	100	22	-	7	5,5	7600ADCAA	760CB0549	784CB0698	7603D00383	7843K00261		
MF 11	x 1	10	DIN 374	90	18	-	8	6,2	7600ADDAA						
MF 12	x 1	11	DIN 374	100	18	-	9	7	7600ADEAA						
MF 12	x 1,25	10,8	DIN 374	100	22	-	9	7	7600ADFAA			7603D00384	7843K00263		
MF 12	x 1,5	10,5	DIN 374	100	22	-	9	7	7600ADGAA	760CB0550	784CB0699	7603D00385	7843K00264		
MF 14	x 1	13	DIN 374	100	18	-	11	9	7600ADIAA						
MF 14	x 1,5	12,5	DIN 374	100	22	-	11	9	7600ADKAA			7603D00386	7843K00266		
MF 15	x 1	14	DIN 374	100	18	-	12	9	7600ADLAA						
MF 16	x 1	15	DIN 374	100	18	-	12	9	7600ADNAA						
MF 16	x 1,5	14,5	DIN 374	100	22	-	12	9	7600ADPAA			7603D00387	7843K00268		
MF 18	x 1	17	DIN 374	110	20	-	14	11	7600ADQAA						
MF 18	x 1,5	16,5	DIN 374	110	25	-	14	11	7600ADRAA						
MF 18	x 2	16	DIN 374	125	26	-	14	11	7600ADSAA						
MF 20	x 1	19	DIN 374	125	20	-	16	12	7600ADTAA						
MF 20	x 1,5	18,5	DIN 374	125	25	-	16	12	7600ADUAA						
MF 20	x 2	18	DIN 374	140	27	-	16	12	7600ADVAA						
MF 22	x 1	21	DIN 374	125	20	-	18	14,5	7600ADWAA						
MF 22	x 1,5	20,5	DIN 374	125	25	-	18	14,5	7600ADXAA						
MF 22	x 2	20	DIN 374	140	27	-	18	14,5	7600ADYAA						
MF 24	x 1	23	DIN 374	140	20	-	18	14,5	7600ADZAA						
MF 24	x 1,5	22,5	DIN 374	140	27	-	18	14,5	7600AD0AA						
MF 24	x 2	22	DIN 374	140	27	-	18	14,5	7600AD1AA						
MF 25	x 1,5	23,5	DIN 374	140	28	-	18	14,5	7600AD3AA						
MF 26	x 1,5	24,5	DIN 374	140	28	-	18	14,5	7600AD4AA						
MF 27	x 1,5	25,5	DIN 374	140	28	-	20	16	7600AD5AA						
MF 27	x 2	25	DIN 374	140	28	-	20	16	7600AD6AA						

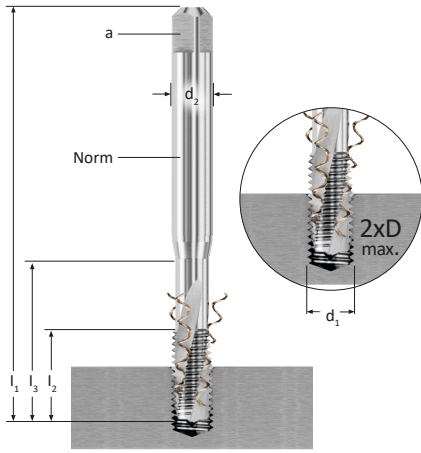

OBERFLÄCHE / SURFACE
SURFACE / SUPERFICIE

SCHNEIDSTOFF / MATERIAL
MATIÈRE / MATERIALE

ANSCHNITTFORM / CHAMFER FORM
FORME D'ENTRÉE / FORMA D'IMBOCCO

-

HSSE

C / 2-3

d_1	P		NORM	l_1	l_2	l_3	d_2	a	ISO2
MF 28 x 1,5	26,5		DIN 374	140	28	-	20	16	7600AD7AA
MF 28 x 2	26		DIN 374	140	28	-	20	16	7600AD8AA
MF 30 x 1,5	28,5		DIN 374	150	28	-	22	18	7600AEAAA
MF 30 x 2	28		DIN 374	150	28	-	22	18	7600AEBAA
MF 32 x 1,5	30,5		DIN 374	150	28	-	22	18	7600AECAA
MF 33 x 1,5	31,5		DIN 374	160	30	-	25	20	7600AEDAA
MF 33 x 2	31		DIN 374	160	30	-	25	20	7600AEEAA
MF 34 x 1,5	32,5		DIN 374	170	30	-	28	22	7600AEFAA
MF 35 x 1,5	33,5		DIN 374	170	30	-	28	22	7600AEGAA
MF 36 x 1,5	34,5		DIN 374	170	30	-	28	22	7600AEHAA
MF 36 x 2	34		DIN 374	170	30	-	28	22	7600AEIAA
MF 36 x 3	33		DIN 374	200	42	-	28	22	7600AEJAA
MF 38 x 1,5	36,5		DIN 374	170	30	-	28	22	7600AEKAA
MF 39 x 2	37		DIN 374	170	30	-	32	24	7600AELAA
MF 40 x 1,5	38,5		DIN 374	170	30	-	32	24	7600AENAA
MF 40 x 2	38		DIN 374	170	30	-	32	24	7600AEPAA
MF 42 x 1,5	40,5		DIN 374	170	30	-	32	24	7600AERAA
MF 42 x 2	40		DIN 374	170	30	-	32	24	7600AESAA
MF 42 x 3	39		DIN 374	200	45	-	32	24	7600AETAA
MF 45 x 1,5	43,5		DIN 374	180	32	-	36	29	7600AEVAA
MF 45 x 2	43		DIN 374	180	32	-	36	29	7600AEWAA
MF 45 x 3	42		DIN 374	200	45	-	36	29	7600AEXAA
MF 48 x 1,5	46,5		DIN 374	190	32	-	36	29	7600AEYAA
MF 48 x 2	46		DIN 374	190	32	-	36	29	7600AEZAA
MF 48 x 3	45		DIN 374	225	50	-	36	29	7600AE0AA
MF 50 x 1,5	48,5		DIN 374	190	32	-	36	29	7600AE1AA
MF 50 x 2	48		DIN 374	190	32	-	36	29	7600AE2AA
MF 52 x 1,5	50,5		DIN 374	190	32	-	40	32	7600AE4AA
MF 52 x 2	50		DIN 374	190	32	-	40	32	7600AE5AA
MF 52 x 3	49		DIN 374	225	50	-	40	32	7600AE6AA

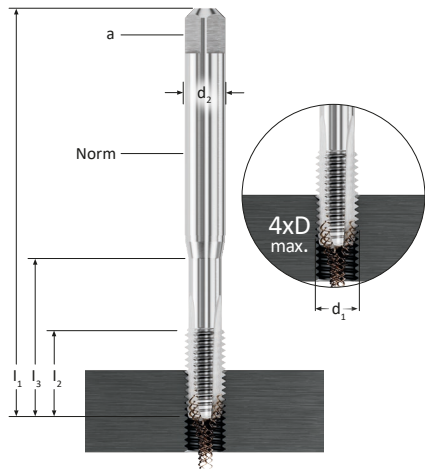

OBERFLÄCHE / SURFACE SURFACE / SUPERFICIE										NITVAP		TIN		ALTIMHD
SCHNEIDSTOFF / MATERIAL MATIÈRE / MATERIALE										HSSE		HSSE		HSSE-PM
ANSCHNITTFORM / CHAMFER FORM FORME D'ENTRÉE / FORMA D'IMBOCCO										B / 4-5		B / 4-5		B / 4-5
d ₁	x	P	NORM	l ₁	l ₂	l ₃	d ₂	a		ISO2	ISO3	ISO2	ISO3	ISO2X
MF 3,5	x	0,35	3,15	DIN 371	56	9	20	4	3					
MF 4	x	0,35	3,65	DIN 374	63	10	-	2,8	2,1					
MF 4	x	0,5	3,5	DIN 371	63	10	21	4,5	3,4	6560A5568		6560A2236		6410K00416
MF 4	x	0,5	3,5	DIN 374	63	10	-	2,8	2,1					
MF 5	x	0,5	4,5	DIN 371	70	11	25	6	4,9	6560A5570		6560A2237		6410K00417
MF 5	x	0,5	4,5	DIN 374	70	11	-	3,5	2,7					
MF 6	x	0,5	5,5	DIN 371	80	13	30	6	4,9	6560A5572		6560A2238		
MF 6	x	0,5	5,5	DIN 374	80	13	-	4,5	3,4	7560AFLAA				
MF 6	x	0,75	5,2	DIN 371	80	13	30	6	4,9	6560A5571		6560A2239		
MF 6	x	0,75	5,2	DIN 374	80	13	-	4,5	3,4	7560AFMAA		7560B0499		
MF 7	x	0,75	6,2	DIN 371	80	13	30	7	5,5					
MF 8	x	0,75	7,2	DIN 371	80	14	30	8	6,2					
MF 8	x	0,75	7,2	DIN 374	80	14	-	6	4,9	7560AFNAA		7560B0500		
MF 8	x	1	7	DIN 371	90	17	35	8	6,2	6560A5574		6560A2240		
MF 8	x	1	7	DIN 374	90	17	-	6	4,9	7560ABMAB	7560A2494	7560ABMAC	7560B0509	7410K00418
MF 9	x	1	8	DIN 371	90	17	35	9	7					
MF 9	x	1	8	DIN 374	90	17	-	7	5,5					
MF 10	x	0,75	9,2	DIN 371	90	15	35	10	8	7560AFPAA		7560B0501		
MF 10	x	0,75	9,2	DIN 374	90	18	-	7	5,5	6560A5577		6560A2241		
MF 10	x	1	9	DIN 371	90	18	35	10	8	7560ABNAC	7560A2496	7560ABNAD	7560B0510	7410K00419
MF 10	x	1	9	DIN 374	90	18	-	7	5,5					
MF 10	x	1,25	8,8	DIN 371	100	18	39	10	8	7560AFQAA		7560B0502		7410K00420
MF 10	x	1,25	8,8	DIN 374	100	22	-	7	5,5					
MF 12	x	1	11	DIN 371	100	18	-	9	7	7560ABDAB	7560A2497	7560A2242	7560B0511	7410K00421
MF 12	x	1,25	10,8	DIN 374	100	22	-	9	7	7560ACLAB		7560B0503		7410K00422
MF 12	x	1,5	10,5	DIN 371	100	22	-	9	7	7560ACNAB	7560A2498	7560ACNAC	7560B0512	7410K00423
MF 12	x	1,5	10,5	DIN 374	100	22	-	9	7					
MF 14	x	1	13	DIN 371	100	18	-	11	9	7560AARAB				
MF 14	x	1,25	12,8	DIN 374	100	22	-	11	9					
MF 14	x	1,5	12,5	DIN 371	100	22	-	11	9	7560ABHAC	7560A2499	7560ABHAD	7560B0513	7410K00424
MF 14	x	1,5	12,5	DIN 374	100	22	-	11	9					
MF 15	x	1	14	DIN 371	100	18	-	12	9					
MF 16	x	1	15	DIN 371	100	18	-	12	9					
MF 16	x	1,5	14,5	DIN 371	100	22	-	12	9	7560AFUAA	7560A2500	7560AFUAB	7560B0514	7410K00425
MF 16	x	1,5	14,5	DIN 374	110	20	-	14	11	7560AFVAA				
MF 18	x	1	17	DIN 371	110	20	-	14	11	7560AA9AA	7560A2501	7560B0504	7560B0515	7410K00426
MF 18	x	2	16	DIN 371	125	26	-	14	11	7560AC0AB				
MF 20	x	1	19	DIN 371	125	20	-	16	12	7560AFWAA				
MF 20	x	1,5	18,5	DIN 371	125	25	-	16	12	7560ABAAA	7560A2502	7560ABAAB	7560B0516	7410K00427
MF 20	x	2	18	DIN 371	140	27	-	16	12					
MF 22	x	1	21	DIN 371	125	20	-	18	14,5					
MF 22	x	1,5	20,5	DIN 371	125	25	-	18	14,5	7560ABBAA		7560A2247		
MF 22	x	2	20	DIN 371	140	27	-	18	14,5					
MF 24	x	1	23	DIN 371	140	20	-	18	14,5					
MF 24	x	1,5	22,5	DIN 371	140	27	-	18	14,5	7560ABCAA		7560B0505		
MF 24	x	2	22	DIN 371	140	27	-	18	14,5	7560ADZAA				
MF 25	x	1,5	23,5	DIN 371	140	28	-	18	14,5	7560AF1AA				
MF 26	x	1,5	24,5	DIN 371	140	28	-	18	14,5	7560AF2AA				
MF 27	x	1,5	25,5	DIN 371	140	28	-	20	16					
MF 27	x	2	25	DIN 371	140	28	-	20	16	7560AF4AA				
MF 28	x	1,5	26,5	DIN 371	140	28	-	20	16	7560AF5AA				
MF 28	x	2	26	DIN 371	140	28	-	20	16					
MF 30	x	1,5	28,5	DIN 371	150	28	-	22	18	7560ACPAA				

NORIS STABIL

ST

HR

VA

NW



-				TIN	TIN	ALTiNHd	NIT	DLC	
HSSE				HSSE	HSSE-PM	HSSE-PM	HSSE	HSSE	
B / 4-5				B / 4-5		B / 4-5	B / 4-5	B / 4-5	
ISO1	ISO2	ISO2 - LH	ISO3	ISO2	ISO2X	ISO2X	ISO2	ISO2	d ₁ x P
	6080A1824								MF 3,5 x 0,35
	7080B0489			7080D00055					MF 4 x 0,35
	6080A1827								MF 4 x 0,5
	7080B0490			7080D00056					MF 4 x 0,5
	6080A1828								MF 5 x 0,5
	7080ABVAA			7080D00057					MF 5 x 0,5
	6080A1832								MF 6 x 0,5
	7080ABWAA			7080D00058					MF 6 x 0,5
	6080A1833								MF 6 x 0,75
	7080ABXAA			7080D00059			7535AAPAA		MF 6 x 0,75
	6080B0040								MF 7 x 0,75
	6080A1837								MF 8 x 0,75
	7080AB0AA			7080D00060			7535AAQAA		MF 8 x 0,75
	6080A1838								MF 8 x 1
7080A2071	7080AB1AA	7080A2180	7080A2129	7080D00061	7160A5312	7533D00363	7535B0520	7571F0042	MF 8 x 1
	6080B0041								MF 9 x 1
	6080A1844								MF 10 x 0,75
	7080AB3AA			7080D00062			7535B0521		MF 10 x 0,75
	6080A1847								MF 10 x 1
7080A2073	7080AB4AA	7080A2182	7080A2131	7080D00063	7160A5316	7533D00364	7535AARAA	7571F0043	MF 10 x 1
	6080A1845								MF 10 x 1,25
	7080AB5AA			7080D00064	7160A5315	7533D00365		7571F0044	MF 10 x 1,25
7080A2074	7080AB7AA	7080A2183	7080A2132	7080D00065			7535B0522	7571F0045	MF 12 x 1
	7080AB8AA			7080D00066		7533D00366		7571F0046	MF 12 x 1,25
7080A2075	7080AB9AA	7080A2184	7080A2133	7080D00067	7160AAAAA	7533D00367	7535AATAA	7571F0047	MF 12 x 1,5
	7080ACAAA			7080D00068				7571F0048	MF 14 x 1
	7080ACBAA			7080D00069				7571F0049	MF 14 x 1,25
7080A2076	7080ACCAA	7080A2186	7080A2134	7080D00070	7160AABAA	7533D00368	7535AAUAA	7571F0050	MF 14 x 1,5
	7080ACDAA								MF 15 x 1
	7080ACFAA			7080D00071				7571F0051	MF 16 x 1
7080A2077	7080ACGAA	7080A2187	7080A2135	7080D00072	7160A5319	7533D00369	7535AAVAA	7571F0052	MF 16 x 1,5
	7080ACHAA								MF 18 x 1
7080A2078	7080ACIAA	7080A2188	7080A2136		7160A5320		7535AAWAA		MF 18 x 1,5
	7080ACJAA								MF 18 x 2
	7080ACKAA			7080D00073					MF 20 x 1
7080A2079	7080ACLAA	7080A2189	7080A2137	7080D00074	7160A5321		7535AAXAA		MF 20 x 1,5
	7080ACMAA			7080D00075					MF 20 x 2
	7080ACNAA								MF 22 x 1
	7080ACPAA			7080D00076			7535AAYAA		MF 22 x 1,5
	7080ACQAA			7080D00077					MF 22 x 2
	7080ACRAA								MF 24 x 1
	7080ACSAA			7080D00078			7535AAZAA		MF 24 x 1,5
	7080ACTAA			7080D00079					MF 24 x 2
	7080ACUAA								MF 25 x 1,5
	7080ACVAA			7080D00080			7535AA0AA		MF 26 x 1,5
	7080ACWAA								MF 27 x 1,5
	7080ACXAA			7080D00081					MF 27 x 2
	7080ACYAA						7535AA1AA		MF 28 x 1,5
	7080A1876								MF 28 x 2
	7080AC0AA			7080D00082			7535AA2AA		MF 30 x 1,5

* weitere Abmessungen siehe Seite 46 | further dimensions see page 46 | pour plus de dimensions, voir page 46 | per le altre dimensioni andare a pagina 46

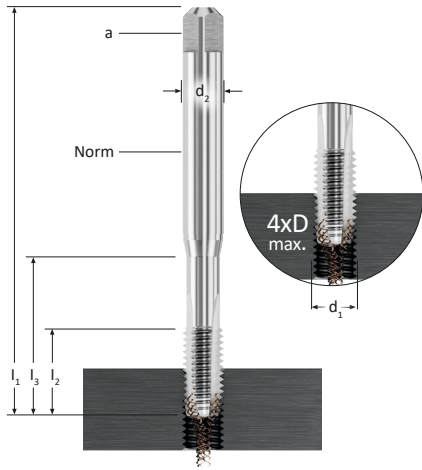

OBERFLÄCHE / SURFACE SURFACE / SUPERFICIE										-	TIN
SCHNEIDSTOFF / MATERIAL MATIÈRE / MATERIALE										HSSE	HSSE
ANSCHNITTFORM / CHAMFER FORM FORME D'ENTRÉE / FORMA D'IMBOCCO										B / 4-5	B / 4-5
d_1	x	P	NORM	l_1	l_2	l_3	d_2	a		ISO2	ISO2
MF 30	x	2	28	DIN 374	150	28	-	22	18	7080AC1AA	7080D00083
MF 32	x	1,5	30,5	DIN 374	150	28	-	22	18	7080AC2AA	
MF 32	x	2	30	DIN 374	150	28	-	22	18	7080A1879	
MF 33	x	1,5	31,5	DIN 374	160	30	-	25	20	7080AC3AA	
MF 33	x	2	31	DIN 374	160	30	-	25	20	7080AC4AA	7080D00084
MF 34	x	1,5	32,5	DIN 374	170	30	-	28	22	7080AC5AA	
MF 35	x	1,5	33,5	DIN 374	170	30	-	28	22	7080AC6AA	
MF 36	x	1,5	34,5	DIN 374	170	30	-	28	22	7080AC7AA	7080D00085
MF 36	x	2	34	DIN 374	170	30	-	28	22	7080AC8AA	7080D00086
MF 36	x	3	33	DIN 374	200	42	-	28	22	7080AC9AA	7080D00087
MF 38	x	1,5	36,5	DIN 374	170	30	-	28	22	7080ADAAA	
MF 39	x	1,5	37,5	DIN 374	170	30	-	32	24	7080A1889	
MF 39	x	2	37	DIN 374	170	30	-	32	24	7080ADBAA	
MF 40	x	1,5	38,5	DIN 374	170	30	-	32	24	7080ADDAA	7080D00088
MF 40	x	2	38	DIN 374	170	30	-	32	24	7080ADEAA	7080D00089
MF 42	x	1,5	40,5	DIN 374	170	30	-	32	24	7080ADGAA	7080D00090
MF 42	x	2	40	DIN 374	170	30	-	32	24	7080ADHAA	7080D00091
MF 42	x	3	39	DIN 374	200	45	-	32	24	7080ADIAA	7080D00092
MF 45	x	1,5	43,5	DIN 374	180	32	-	36	29	7080ADJAA	7080D00093
MF 45	x	2	43	DIN 374	180	32	-	36	29	7080ADKAA	7080D00094
MF 45	x	3	42	DIN 374	200	45	-	36	29	7080ADLAA	7080D00095
MF 48	x	1,5	46,5	DIN 374	190	32	-	36	29	7080ADMAA	7080D00096
MF 48	x	2	46	DIN 374	190	32	-	36	29	7080ADNAA	7080D00097
MF 48	x	3	45	DIN 374	225	50	-	36	29	7080ADPAA	7080D00098
MF 50	x	1,5	48,5	DIN 374	190	32	-	36	29	7080ADQAA	
MF 50	x	2	48	DIN 374	190	32	-	36	29	7080ADRAA	
MF 52	x	1,5	50,5	DIN 374	190	32	-	40	32	7080ADTAA	
MF 52	x	2	50	DIN 374	190	32	-	40	32	7080A1904	
MF 52	x	3	49	DIN 374	225	50	-	40	32	7080A1905	



SOLUTIONS@NORIS-REIME.DE

Das REIME Team steht Ihnen bei der Lösung Ihrer Zerspanungsaufgabe gerne zur Seite

The REIME team will be happy to solve your threading tasks

L'équipe de REIME se tient à votre disposition pour résoudre vos problèmes de filetage

Il team REIME sarà lieto di risolvere i vostri problemi di filettatura

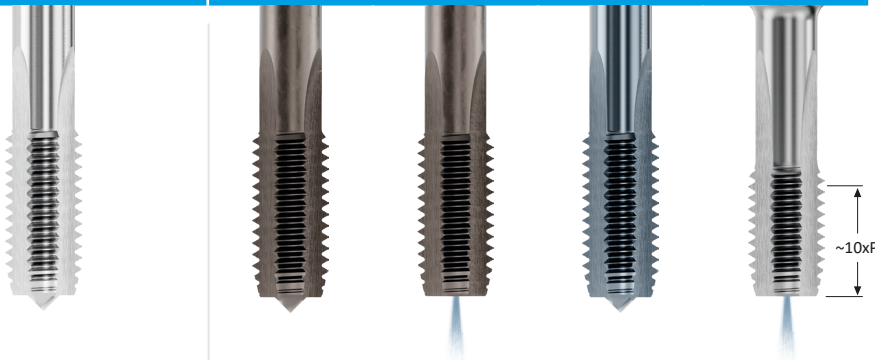
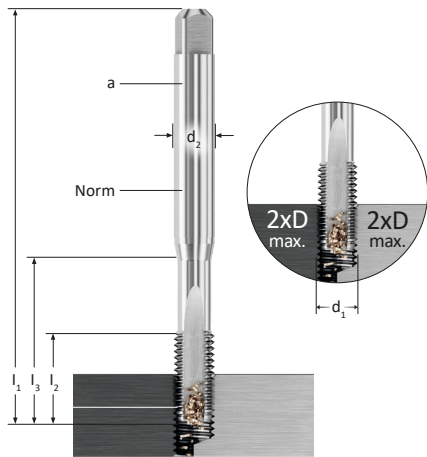

OBERFLÄCHE / SURFACE SURFACE / SUPERFICIE										-		NIT		TICN		-	
SCHNEIDSTOFF / MATERIAL MATIÈRE / MATERIALE										HSSE		HSSE		HSSE		HM	
ANSCHNITTFORM / CHAMFER FORM FORME D'ENTRÉE / FORMA D'IMBOCCO										C / 2-3		C / 2-3		C / 2-3		C / 2-3	
d ₁	x	P	NORM	l ₁	l ₂	l ₃	d ₂	a	ISO2X - LH	ISO2X	ISO2X	ISO2X	ISO2X	ISO2X	ISO2X		
MF 3	x	0,35	2,65	DIN 2181	40	8	18	3,5	2,7	5100A1313		6103A1017					
				DIN 371	56	8	18	3,5	2,7			6103A1018					
MF 3,5	x	0,35	3,15	DIN 2181	45	9	22	4,5	3,4								
				DIN 374	63	10	-	2,8	2,1								
MF 4	x	0,35	3,65	DIN 2181	45	9	22	4,5	3,4								
				DIN 371	63	10	21	4,5	3,4	6100A1342		6100A1173		6103A1019			
				DIN 374	63	10	-	2,8	2,1			7100AA7AA					
MF 4,5	x	0,5	4	DIN 2181	50	10	24	6	4,9			5100A1317					
				DIN 2181	50	11	25	6	4,9			5100A1318					
MF 5	x	0,5	4,5	DIN 371	70	11	25	6	4,9	6100A1343		6100A1177		6103A1020			
				DIN 374	70	11	-	3,5	2,7			7100AA8AA					
MF 6	x	0,5	5,5	DIN 2181	56	12	27	6	4,9	6100A1344		5100A1319		6103A1022			
				DIN 371	80	13	30	6	4,9			6100A1179					
				DIN 374	80	13	-	4,5	3,4			7100AA9AA					
MF 6	x	0,75	5,2	DIN 2181	56	12	27	6	4,9	5100A1492		5100A1320					
				DIN 371	80	13	30	6	4,9	6100A1345		6100A1180		6103A1021			
				DIN 374	80	13	-	4,5	3,4			7100ABAAA					
MF 7	x	0,75	6,2	DIN 2181	56	14	-	6	4,9			5100A1321					
MF 8	x	0,5	7,5	DIN 2181	56	14	-	6	4,9			5100A1322					
				DIN 2181	56	14	-	6	4,9			5100A1323					
				DIN 371	80	14	30	8	6,2			6100A1188					
				DIN 374	80	14	-	6	4,9			7100ABDAA					
MF 8	x	1	7	DIN 2181	63	17	-	6	4,9	5100A1494		5100A1324					
				DIN 371	90	17	35	8	6,2	6100A1347		6100A1187				6300B0318	
				DIN 374	90	17	-	6	4,9			7100ABEAA		7103A1023		7103B0440	
MF 9	x	1	8	DIN 2181	63	17	-	7	5,5			5100A1325					
MF 10	x	0,75	9,2	DIN 2181	63	18	-	7	5,5			5100A1326					
				DIN 374	90	18	-	7	5,5			7100ABIAA					
MF 10	x	1	9	DIN 2181	63	18	-	7	5,5	5100A1495		5100A1327					
				DIN 371	90	18	35	10	8	6100A1348		6100A1195				6300B0319	
				DIN 374	90	18	-	7	5,5			7100ABJAA		7103A1025		7103B0441	
MF 10	x	1,25	8,8	DIN 2181	70	22	-	7	5,5			5100A1328					
				DIN 371	100	18	39	10	8							6300B0320	
				DIN 374	100	22	-	7	5,5			7100ABKAA				7103B0442	
MF 11	x	1	10	DIN 2181	63	18	-	8	6,2			5100A1329					
				DIN 374	90	18	-	8	6,2			7100ABLAA					
MF 12	x	1	11	DIN 2181	70	18	-	9	7	5100A1496		5100A1330					
				DIN 374	100	18	-	9	7			7100ABNAA		7103A1027		7103B0443	
MF 12	x	1,25	10,8	DIN 2181	70	20	-	9	7			5100A1331					
				DIN 374	100	22	-	9	7			7100ABPAA					
MF 12	x	1,5	10,5	DIN 2181	70	20	-	9	7	5100A1497		5100A1332					
				DIN 371	110	21	41	12	9			7100ABQAA		7103A1026		7813A5131	
				DIN 374	100	22	-	9	7							7103B0444	
MF 14	x	1	13	DIN 2181	70	18	-	10	8			5100A1334					
				DIN 374	100	18	-	11	9			7100ABSAA					
MF 14	x	1,25	12,8	DIN 2181	70	20	-	11	9			5100A1335					
				DIN 374	100	22	-	11	9			7100ABTAA					
				DIN 2181	70	20	-	10	8	5100A1499		5100A1336					
MF 14	x	1,5	12,5	DIN 371	110	24	44	14	11								
				DIN 374	100	22	-	11	9			7100ABUAA		7103A1028		7813A5132	
MF 15	x	1	14	DIN 2181	70	18	-	12	9			5100A1337				7103B0445	
				DIN 2181	70	18	-	12	9			5100A1339				7300B0727	
MF 16	x	1	15	DIN 374	100	18	-	12	9			7100ABXAA					
				DIN 2181	70	20	-	12	9	5100A1500		5100A1340					
MF 16	x	1,5	14,5	DIN 371	110	24	44	16	12								
				DIN 374	100	22	-	12	9			7100ABYAA		7103A1029		7813A5133	
																7103B0446	
																7300B0728	

* weitere Abmessungen siehe Seite 50 | further dimensions see page 50 | pour plus de dimensions, voir page 50 | per le altre dimensioni andare a pagina 50

NORIS TWIN

GG

GGV

MS

HT

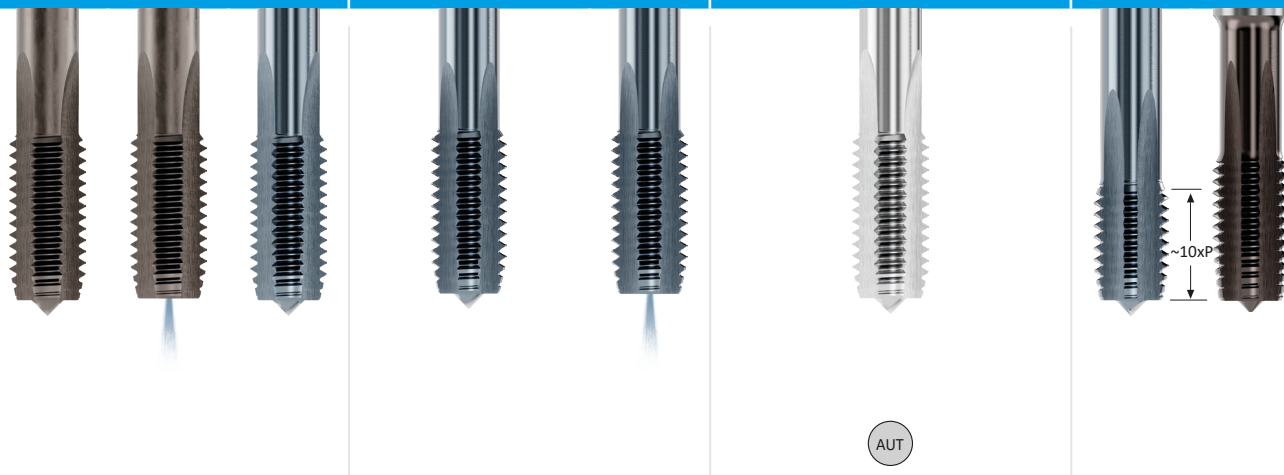

NIT		TICN	TICN			-			TICN	ALTiN	
HSSE		HSSE	HSSE-PM			HSSE			HSSE-PM	HM	
C / 2-3		C / 2-3	C / 2-3	E / 1,5-2	C / 2-3	ekA / 1 max.			C / 2-3	D / 4-5	
ISO2X	ISO2X	ISO2X	ISO2X	ISO2X	ISO2X	ISO2X	ISO3X	ISO2X +0,1 ¹⁾	ISO2X	ISO2X	d ₁ x P
											MF 3 x 0,35
											MF 3,5 x 0,35
											MF 4 x 0,35
											MF 4 x 0,5
											MF 4,5 x 0,5
7200AASAA											MF 5 x 0,5
											MF 6 x 0,5
7200AATAA											MF 6 x 0,75
7200AAUAA											MF 7 x 0,75
											MF 8 x 0,5
											MF 8 x 0,75
7200AAWAA											MF 8 x 1
7200AAXAA		7200B0465				5250F0043	5250F0048		610HF0004	6260E5691	MF 8 x 1
											MF 9 x 1
											MF 10 x 0,75
						5250F0044	5250F0049				MF 10 x 1
7200AAYAA		7200B0466							610HF0005	6260E1723	MF 10 x 1
											MF 10 x 1,25
											MF 11 x 1
7200AAZAA		7200B0467				5250F0067	5250F0120	5250F0122			MF 12 x 1
											MF 12 x 1,25
7200AA0AA	7820AAHAA	7200B0468	720GF0003	720GF0008	782GF0004	5250F0045	5250F0050		710HF0004	6260F0007	MF 12 x 1,5
							5250F0181	5250F0180			MF 14 x 1
7200AA1AA											MF 14 x 1,25
						5250F0046	5250F0051				MF 14 x 1,5
7200AA2AA	7820AAIAA	7200B0469	720GF0004	720GF0009	782GF0005				710HF0005	6260F0008	MF 14 x 1,5
							5250F0126				MF 15 x 1
											MF 16 x 1
7200AA3AA	7820AAJAA	7200B0470	720GF0005	720GF0010	782GF0006	5250F0047	5250F0052	5250F0123	710HF0006	6260F0009	MF 16 x 1,5

1) - $\varnothing +0,1$ mm

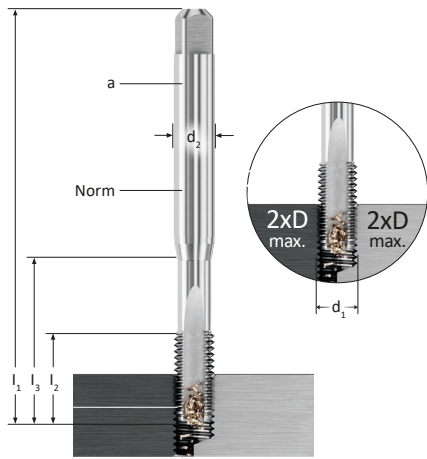

OBERFLÄCHE / SURFACE SURFACE / SUPERFICIE											-		NIT		TICN	-
SCHNEIDSTOFF / MATERIAL MATIÈRE / MATERIALE											HSSE		HSSE		HSSE	HM
ANSCHNITTFORM / CHAMFER FORM FORME D'ENTRÉE / FORMA D'IMBOCCO											C / 2-3		C / 2-3		C / 2-3	C / 2-3
d ₁	x	P	NORM	l ₁	l ₂	l ₃	d ₂	a	ISO2X - LH	ISO2X	ISO2X	ISO2X	ISO2X	ISO2X		
MF 18	x	1	17	DIN 2181	80	18	-	14	11		5100A1341					
				DIN 374	110	20	-	14	11		7100ABZAA					
MF 18	x	1,5	16,5	DIN 2181	80	22	-	12	9	5100A1501						
				DIN 374	110	25	-	14	11		7100AB0AA	7103A1030		7103B0447		
MF 18	x	2	16	DIN 2181	80	22	-	14	11		5100A1343					
				DIN 374	125	26	-	14	11		7100AB1AA					
MF 20	x	1	19	DIN 374	125	20	-	16	12		7100AB2AA					
MF 20	x	1,5	18,5	DIN 2181	80	22	-	15	12	5100A1502						
				DIN 374	125	25	-	16	12		5100A1345					
				DIN 2181	80	22	-	16	12		7100AB3AA	7103A1031	7813A5134	7103B0448	7300B0729	
				DIN 374	140	27	-	16	12		5100A1346					
MF 22	x	1	21	DIN 374	125	20	-	18	14,5		7100AB4AA					
				DIN 2181	80	22	-	15	12		7100AB5AA					
MF 22	x	1,5	20,5	DIN 374	125	25	-	18	14,5		5100A1348					
				DIN 2181	80	22	-	18	14,5		7100AB6AA	7103B0419		7103B0449		
				DIN 374	140	27	-	18	14,5		5100A1349					
MF 24	x	1	23	DIN 374	140	20	-	18	14,5		7100AB7AA					
				DIN 2181	90	22	-	18	14,5		7100AB8AA					
MF 24	x	1,5	22,5	DIN 374	140	27	-	18	14,5		5100A1351					
				DIN 2181	90	22	-	18	14,5		7100AB9AA	7103B0420		7103B0450		
				DIN 374	140	27	-	18	14,5		5100A1352					
MF 25	x	1,5	23,5	DIN 374	140	28	-	18	14,5		7100ACAAA					
MF 26	x	1,5	24,5	DIN 374	140	28	-	18	14,5		7100ACBAA					
MF 27	x	1,5	25,5	DIN 374	140	28	-	20	16		7100ACCAA					
MF 27	x	2	25	DIN 374	140	28	-	20	16		7100ACEAA					
MF 28	x	1,5	26,5	DIN 374	140	28	-	20	16		7100ACFAA					
MF 28	x	2	26	DIN 374	140	28	-	20	16		7100ACGAA					
MF 30	x	1,5	28,5	DIN 374	150	28	-	22	18		7100ACHAA					
MF 30	x	2	28	DIN 374	150	28	-	22	18		7100ACJAA					
MF 32	x	1,5	30,5	DIN 374	150	28	-	22	18		7100ACKAA					
MF 32	x	2	30	DIN 374	150	28	-	22	18		7100ACLAA					
MF 33	x	1,5	31,5	DIN 374	160	30	-	25	20		7100ACMAA					
MF 33	x	2	31	DIN 374	160	30	-	25	20		7100ACNAA					
MF 34	x	1,5	32,5	DIN 374	170	30	-	28	22		7100ACPAA					
MF 35	x	1,5	33,5	DIN 374	170	30	-	28	22		7100ACQAA					
MF 36	x	1,5	34,5	DIN 374	170	30	-	28	22		7100ACRAA					
MF 36	x	2	34	DIN 374	170	30	-	28	22		7100ACSA A					
MF 36	x	3	33	DIN 374	200	42	-	28	22		7100ACTAA					
MF 38	x	1,5	36,5	DIN 374	170	30	-	28	22		7100A1237					
MF 39	x	1,5	37,5	DIN 374	170	30	-	32	24		7100ACVAA					
MF 39	x	2	37	DIN 374	170	30	-	32	24		7100A1239					
MF 40	x	1,5	38,5	DIN 374	170	30	-	32	24		7100A1240					
MF 40	x	2	38	DIN 374	170	30	-	32	24		7100AEC A A					
MF 42	x	1,5	40,5	DIN 374	170	30	-	32	24		7100ACZAA					
MF 42	x	2	40	DIN 374	170	30	-	32	24		7100AC1AA					
MF 42	x	3	39	DIN 374	200	45	-	32	24		7100AC2AA					
MF 45	x	1,5	43,5	DIN 374	180	32	-	36	29		7100AC3AA					
MF 45	x	2	43	DIN 374	180	32	-	36	29		7100A1249					
MF 45	x	3	42	DIN 374	200	45	-	36	29		7100A1248					
MF 48	x	1,5	46,5	DIN 374	190	32	-	36	29		7100A1247					
MF 48	x	2	46	DIN 374	190	32	-	36	29		7100AC8AA					
MF 48	x	3	45	DIN 374	225	50	-	36	29		7100AC9AA					
MF 50	x	1,5	48,5	DIN 374	190	32	-	36	29		7100ADAAA					
MF 50	x	2	48	DIN 374	190	32	-	36	29		7100ADBAA					
MF 52	x	1,5	50,5	DIN 374	190	32	-	40	32		7100A1253					
MF 52	x	2	50	DIN 374	190	32	-	40	32		7100ADEAA					
MF 52	x	3	49	DIN 374	225	50	-	40	32		7100A1256					
											7100A1257					

NORIS TWIN
GGV

GG

MS



NIT		TICN			-		
HSSE		HSSE-PM			HSSE		
C / 2-3		C / 2-3	E / 1,5-2	C / 2-3	eka / 1 max.		
ISO2X	ISO2X	ISO2X	ISO2X	ISO2X	ISO2X	ISO3X	d ₁ x P
							MF 18 x 1
							MF 18 x 1
7200AA4AA		720GF0006	720GF0011	782GF0007	5250F0187	5250F0182	MF 18 x 1,5
							MF 18 x 1,5
							MF 18 x 2
							MF 18 x 2
							MF 20 x 1
7200AA5AA	7820AALAA	720GK00335	720GK00337		5250F0075	5250F0183	MF 20 x 1,5
							MF 20 x 1,5
							MF 20 x 2
							MF 20 x 2
							MF 22 x 1
7200AA6AA					5250F0107	5250F0184	MF 22 x 1,5
							MF 22 x 1,5
							MF 22 x 2
							MF 22 x 2
							MF 24 x 1
7200AA7AA					5250F0179	5250F0185	MF 24 x 1,5
							MF 24 x 1,5
							MF 24 x 2
							MF 24 x 2
7200AA8AA							MF 25 x 1,5
							MF 26 x 1,5
							MF 27 x 1,5
							MF 27 x 2
7200AA9AA							MF 28 x 1,5
							MF 28 x 2
7200ABAAA							MF 30 x 1,5
							MF 30 x 2
							MF 32 x 1,5
							MF 32 x 2
							MF 33 x 1,5
							MF 33 x 2
							MF 34 x 1,5
							MF 35 x 1,5
							MF 36 x 1,5
							MF 36 x 2
							MF 36 x 3
							MF 38 x 1,5
							MF 39 x 1,5
							MF 39 x 2
							MF 40 x 1,5
							MF 40 x 2
							MF 42 x 1,5
							MF 42 x 2
							MF 42 x 3
							MF 45 x 1,5
							MF 45 x 2
							MF 45 x 3
							MF 48 x 1,5
							MF 48 x 2
							MF 48 x 3
							MF 50 x 1,5
							MF 50 x 2
							MF 52 x 1,5
							MF 52 x 2
							MF 52 x 3

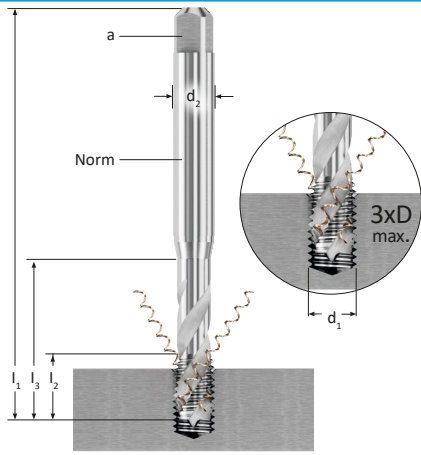

OBERFLÄCHE / SURFACE SURFACE / SUPERFICIE										VAP		ALTiNHD	
SCHNEIDSTOFF / MATERIAL MATIÈRE / MATERIALE										HSSE		HSSE	
ANSCHNITTFORM / CHAMFER FORM FORME D'ENTRÉE / FORMA D'IMBOCCO										C / 2-3		C / 2-3	
d ₁	- P/1"		NORM	l ₁	l ₂	l ₃	d ₂	a	2B	2B +0,05 ¹⁾	2B	2B +0,05 ¹⁾	
UNC NR 2	- 56	1,85	≈ 371	45	4,5	-	2,8	2,1	6642AINAA		6470D00327		
UNC NR 4	- 40	2,35	≈ 371	56	6	18	3,5	2,7	6642ADZAA		6470D00328		
UNC NR 6	- 32	2,85	≈ 371	56	7	20	4	3	6642ACMAA	6642A4094	6470D00329	6470D00335	
UNC NR 8	- 32	3,5	≈ 371	63	8	21	4,5	3,4	6642ACNAA	6642A4095	6470D00330	6470D00336	
UNC NR 10	- 24	3,9	≈ 371	70	10	25	6	4,9	6642ACPAA	6642A4096	6470D00331	6470D00337	
UNC 1/4	- 20	5,1	≈ 371	80	13	30	7	5,5	6642ACRAA	6642A4097	6470D00332	6470D00338	
UNC 5/16	- 18	6,6	≈ 371	90	14	35	8	6,2	6642ACSAA	6642A4098	6470D00333	6470D00339	
UNC 3/8	- 16	8	≈ 371	100	16	39	10	8	6642ACTAA	6642A4099	6470D00334	6470D00340	
			≈ 376	100	16	-	7	5,5			7470D00341		
UNC 7/16	- 14	9,4	≈ 376	100	18	-	8	6,2	7642F0059	7642A4100	7470D00342	7470D00347	
UNC 1/2	- 13	10,8	≈ 376	110	20	-	9	7	7642ADIAA	7642A4101	7470D00343	7470D00348	
UNC 9/16	- 12	12,2	≈ 376	110	20	-	11	9	7642ADYAA				
UNC 5/8	- 11	13,5	≈ 376	110	22	-	12	9	7642ADJAA	7642A4103	7470D00344	7470D00349	
UNC 3/4	- 10	16,5	≈ 376	125	25	-	14	11	7642ADKAA	7642A4104	7470D00345	7470D00350	
UNC 7/8	- 9	19,5	≈ 376	140	27	-	18	14,5	7642ADLAA				
UNC 1	- 8	22,25	≈ 376	160	30	-	18	14,5	7642ADMAA	7642A4105	7470D00346	7470D00351	
UNC 1 1/4	- 7	28	≈ 376	180	35	-	22	18					
UNC 1 1/2	- 6	34	≈ 376	200	40	-	28	22					
UNC 1 3/4	- 5	39,5	≈ 376	220	45	-	36	29					
UNC 2	- 4,5	45	≈ 376	250	50	-	40	32					

1) - $\varnothing + 0,05$ mm

NORIS SALOREX
VA

ST



VR



-		VAP	ALTINH D	TIBLU		
HSSE		HSSE	HSSE	HSSE-PM		
C / 2-3		C / 2-3	E / 1,5-2	C / 2-3	E / 1,5-2	
2B	3B	2B	2B	2BX	2BX	d ₁ - P/1"
6640A3618			6645B0249			UNC NR 2 - 56
6640A3620	6640A3724		6645B0250	6655K00145	6655K00168	UNC NR 4 - 40
6640A3622	6640AC3AA	6645AARAA	6645B0251	6655K00146	6655K00169	UNC NR 6 - 32
6640ACRAA	6640AC4AA	6645AAWAA	6645B0252	6655K00147	6655K00170	UNC NR 8 - 32
6640ACSA A	6640AC5AA	6645AA6AA	6645B0253	6655K00143	6655K00166	UNC NR 10 - 24
6640ACUAA	6640AC7AA	6645AA2AA	6645B0254	6655K00125	6655K00148	UNC 1/4 - 20
6640ACVAA	6640AC8AA	6645AAJAA	6645B0255	6655K00129	6655K00152	UNC 5/16 - 18
6640ACWAA	6640AC9AA	6645ABDAA	6645B0256	6655K00127	6655K00150	UNC 3/8 - 16
7640A3631			7645B0622			
7640A3632	7640A3734	7645A4049	7645B0623	7655K00184	7655K00224	UNC 7/16 - 14
7640ADEAA	7640A3735	7645ABTAA	7645B0624	7655K00178	7655K00218	UNC 1/2 - 13
						UNC 9/16 - 12
7640ADGAA	7640A3737	7645AAPAA	7645B0625	7655K00182	7655K00222	UNC 5/8 - 11
7640ADHAA	7640A3738	7645AAUAA	7645B0626	7655K00180	7655K00220	UNC 3/4 - 10
7640ADIAA						UNC 7/8 - 9
7640ADJAA		7645ABCAA	7645B0627	7655K00177	7655K00217	UNC 1 - 8
7640ADLAA						UNC 1 1/4 - 7
7640ADNAA						UNC 1 1/2 - 6
7640A3650						UNC 1 3/4 - 5
7640A3651						UNC 2 - 4,5

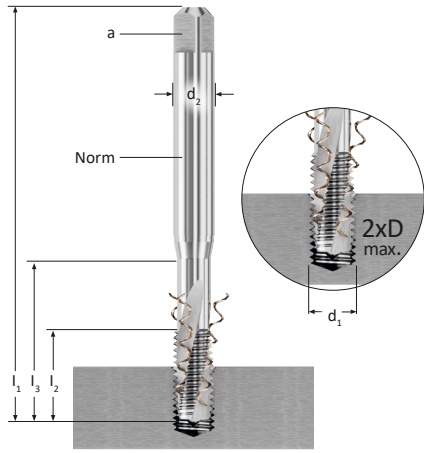

OBERFLÄCHE / SURFACE SURFACE / SUPERFICIE		VAP	
SCHNEIDSTOFF / MATERIAL MATIÈRE / MATERIALE		HSSE-PM	
ANSCHNITTFORM / CHAMFER FORM FORME D'ENTRÉE / FORMA D'IMBOCCO		C / 2-3	
d_1	- P/1"	NORM	2BX
UNC NR 4	- 40	2,35 ≈ 371	6614ABKAA
UNC NR 6	- 32	2,85 ≈ 371	6614ABMAA
UNC NR 8	- 32	3,5 ≈ 371	6614ABNAA
UNC NR 10	- 24	3,9 ≈ 371	6614ABPAA
UNC 1/4	- 20	5,1 ≈ 371	6614ABRAA
UNC 5/16	- 18	6,6 ≈ 371	6614AA5AA

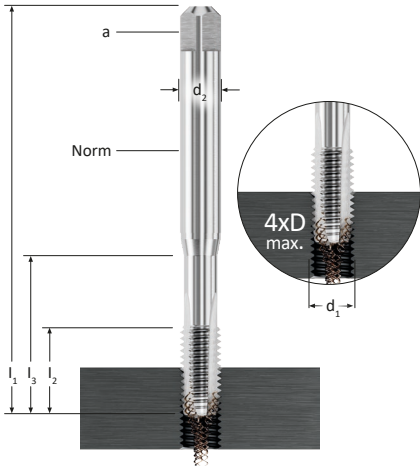

OBERFLÄCHE / SURFACE SURFACE / SUPERFICIE										NITVAP		-		NIT		VAP		TIN		
SCHNEIDSTOFF / MATERIAL MATIÈRE / MATERIALE										HSSE		HSSE		HSSE		HSSE-PM		HSSE-PM		
ANSCHNITTFORM / CHAMFER FORM FORME D'ENTRÉE / FORMA D'IMBOCCO										B / 4-5		B / 4-5		B / 4-5		B / 4-5		B / 4-5		
d ₁	- P/1"		NORM	l ₁	l ₂	l ₃	d ₂	a			2B	3B	2B	3B	2B	2BX	2BX			
UNC NR 2	- 56	1,85	≈ 371	45	7	-	2,8	2,1			6560AB1AA				6080ACYAA					
UNC NR 4	- 40	2,35	≈ 371	56	11	18	3,5	2,7			6560AB3AA				6080AC0AA			6084A2045	6084A2053	
UNC NR 6	- 32	2,85	≈ 371	56	12	20	4	3			6560AB5AA	6560ACCAA			6080AC2AA		6535AAPAA	6084A2046	6084A2054	
UNC NR 8	- 32	3,5	≈ 371	63	13	21	4,5	3,4			6560AB6AA	6560ACDAA			6080AC3AA		6535AAQAA	6084A2047	6084A2055	
UNC NR 10	- 24	3,9	≈ 371	70	15	25	6	4,9			6560AB7AA				6080AC4AA		6535AARAA	6084A2048	6084A2056	
UNC 1/4	- 20	5,1	≈ 371	80	17	30	7	5,5			6560AB9AA	6560ACFAA			6080AC6AA		6535AATAA	6084A2049	6084A2057	
UNC 5/16	- 18	6,6	≈ 371	90	20	35	8	6,2			6560ABNAA				6080AC7AA		6535AAUAA	6084A2050	6084A2058	
UNC 3/8	- 16	8	≈ 376	100	22	39	10	8			6560ABPAA				6080AC8AA		6535AAVAA	6084A2051	6084A2059	
UNC 7/16	- 14	9,4	≈ 376	100	22	-	8	6,2			7560A2395			7080B0491	7080A2092	7535A2012				
UNC 1/2	- 13	10,8	≈ 376	110	25	-	9	7			7560AC7AA			7080AGKAA	7080A2093	7535AA3AA	7084A2052	7084A2060		
UNC 5/8	- 11	13,5	≈ 376	110	27	-	12	9			7560AC8AA			7080AGMAA	7080A2095	7535AA5AA				
UNC 3/4	- 10	16,5	≈ 376	125	30	-	14	11			7560AC9AA			7080AGNAA	7080A2096	7535AA6AA				
UNC 7/8	- 9	19,5	≈ 376	140	32	-	18	14,5			7560ADAAA			7080AGPAA		7535AA7AA				
UNC 1	- 8	22,25	≈ 376	160	36	-	18	14,5			7560AB9AB			7080AGQAA		7535AA8AA				
UNC 1 1/4	- 7	28	≈ 376	180	40	-	22	18						7080AGSAA						
UNC 1 1/2	- 6	34	≈ 376	200	50	-	28	22						7080AGUAA						
UNC 1 3/4	- 5	39,5	≈ 376	220	58	-	36	29						7080AGVAA						
UNC 2	- 4,5	45	≈ 376	250	65	-	40	32						7080AGWAA						

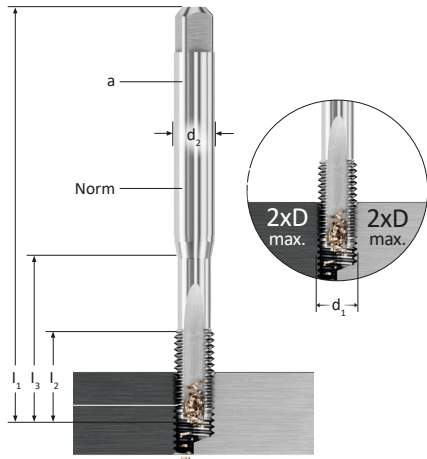

OBERFLÄCHE / SURFACE SURFACE / SUPERFICIE										NIT	
SCHNEIDSTOFF / MATERIAL MATIÈRE / MATERIALE										HSSE	
ANSCHNITTFORM / CHAMFER FORM FORME D'ENTRÉE / FORMA D'IMBOCCO										C / 2-3	
d_1	- P/1"	NORM	l_1	l_2	l_3	d_2	a	2BX		2BX	
UNC NR 4	- 40	2,35	≈ 371	56	11	18	3,5	2,7	6103A1054	6200A1087	
UNC NR 6	- 32	2,85	≈ 371	56	12	20	4	3	6103A1056	6200A1089	
UNC NR 8	- 32	3,5	≈ 371	63	13	21	4,5	3,4	6103A1057	6200A1090	
UNC NR 10	- 24	3,9	≈ 371	70	15	25	6	4,9	6103A1058	6200AA9AA	
UNC 1/4	- 20	5,1	≈ 371	80	17	30	7	5,5	6103A1060	6200ABBAA	
UNC 5/16	- 18	6,6	≈ 371	90	20	35	8	6,2	6103A1061	6200ABCAA	
UNC 3/8	- 16	8	≈ 371	100	22	39	10	8	6103A1062	6200ABDAA	
UNC 7/16	- 14	9,4	≈ 376	100	22	-	8	6,2	7103A1063		
UNC 1/2	- 13	10,8	≈ 376	110	25	-	9	7	7103A1065	7200ACPAA	
UNC 9/16	- 12	12,2	≈ 376	110	26	-	11	9	7103A1066	7200A1099	
UNC 5/8	- 11	13,5	≈ 376	110	27	-	12	9	7103A1067	7200ACQAA	
UNC 3/4	- 10	16,5	≈ 376	125	30	-	14	11	7103A1068	7200ACRAA	
UNC 7/8	- 9	19,5	≈ 376	140	32	-	18	14,5	7103A1069	7200ACSA A	
UNC 1	- 8	22,25	≈ 376	160	36	-	18	14,5	7103A1070	7200ACTAA	

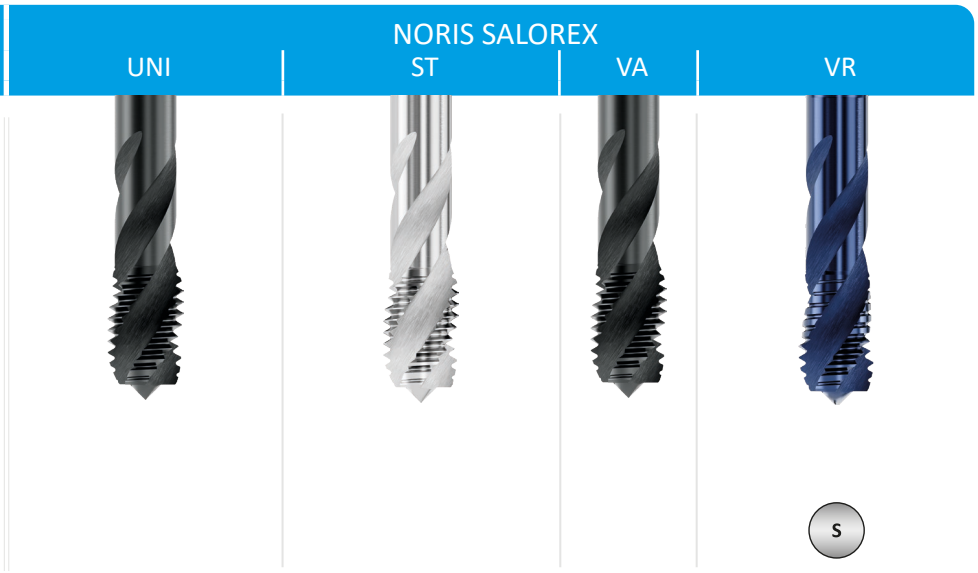
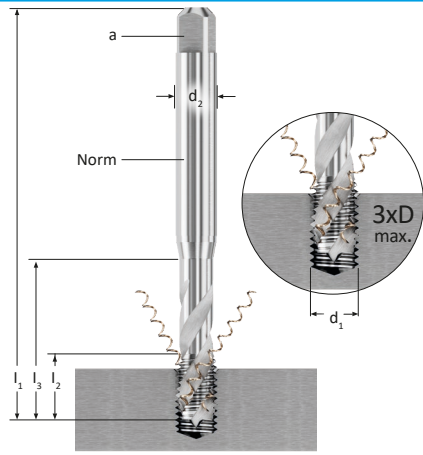

OBERFLÄCHE / SURFACE SURFACE / SUPERFICIE									VAP		-		VAP		TIBLU	
SCHNEIDSTOFF / MATERIAL MATIÈRE / MATERIALE									HSSE		HSSE		HSSE		HSSE-PM	
ANSCHNITTFORM / CHAMFER FORM FORME D'ENTRÉE / FORMA D'IMBOCCO									C / 2-3		C / 2-3		E / 1,5-2		C / 2-3	E / 1,5-2
d ₁	- P/1"		NORM	l ₁	l ₂	l ₃	d ₂	a	2B	2B +0,05 ¹⁾	2B	3B	2B	2BX	2BX	
UNF NR 2	- 64	1,85	≈ 371	45	4,5	12	2,8	2,1			6640A3652			6645A1873		
UNF NR 4	- 48	2,4	≈ 371	56	6	18	3,5	2,7	6642A3939		6640A3654			6645A1875		
UNF NR 6	- 40	2,95	≈ 371	56	7	20	4	3	6642ACHAA	6642A4461	6640ACGAA	6640ADGAA		6645A1877		
UNF NR 8	- 36	3,5	≈ 371	63	8	21	4,5	3,4	6642ACIAA	6642A4462	6640ACHAA	6640ADHAA	6645AAUAA			
UNF NR 10	- 32	4,1	≈ 371	70	10	25	6	4,9	6642ACJAA	6642A4463	6640ACIAA	6640A3741	6645A1871	6655K00144	6655K00167	
UNF 1/4	- 28	5,5	≈ 371	80	10	30	7	5,5	6642ACLAA	6642A4464	6640ACKAA	6640A3743	6645A1872	6655K00126	6655K00149	
			≈ 376	80	10	-	4,5	3,4			7640A3661					
UNF 5/16	- 24	6,9	≈ 371	90	10	35	8	6,2	6642A3948	6642A4465	6640A3662	6640A3744	6645A1878	6655K00130	6655K00153	
			≈ 376	90	10	-	6	4,9			7640AC1AA					
UNF 3/8	- 24	8,5	≈ 371	90	10	35	10	8	6642A3949	6642A4466	6640A3665	6640A3745	6645A1879	6655K00128	6655K00151	
			≈ 376	90	10	-	7	5,5			7640AC2AA	7640ADQAA				
UNF 7/16	- 20	9,9	≈ 376	100	13	-	8	6,2	7642ADCAA	7642A4467	7640AC3AA	7640ADRAA		7655K00185	7655K00225	
UNF 1/2	- 20	11,5	≈ 376	100	13	-	9	7	7642ADDAA	7642A4468	7640AC4AA	7640ADSAA		7655K00179	7655K00219	
UNF 9/16	- 18	12,9	≈ 376	100	15	-	11	9	7642AFNAB	7642A4469	7640AC5AA	7640A3749				
UNF 5/8	- 18	14,5	≈ 376	100	15	-	12	9	7642ADEAA	7642A4470	7640AC6AA	7640A3750		7655K00183	7655K00223	
UNF 3/4	- 16	17,5	≈ 376	110	17	-	14	11	7642ADFAA	7642A4471	7640AC7AA	7640A3751		7655K00181	7655K00221	
UNF 7/8	- 14	20,4	≈ 376	125	17	-	18	14,5	7642ADGAA		7640AC8AA					
UNF 1	- 12	23,25	≈ 376	140	20	-	18	14,5	7642ADHAA	7642A4472	7640AC9AA			7655K00176	7655K00216	
UNF 1 1/8	- 12	26,5	≈ 376	150	22	-	22	18	7642AT0AB		7640ADAAA					
UNF 1 1/4	- 12	29,5	≈ 376	150	22	-	22	18	7642ALFAA		7640ADBAA					
UNF 1 3/8	- 12	32,75	≈ 376	170	24	-	28	22	7642AT1AB		7640ADCAA					
UNF 1 1/2	- 12	36	≈ 376	170	24	-	28	22	7642AKIAA		7640A3678					

1) - Ø + 0,05 mm

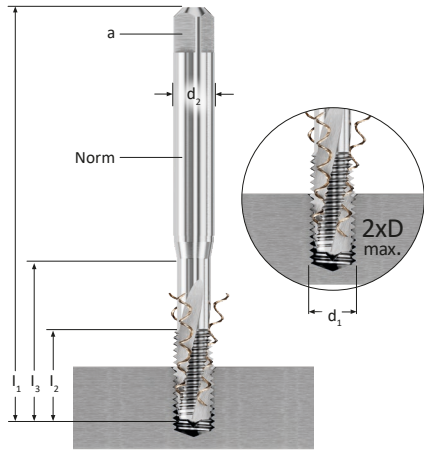

OBERFLÄCHE / SURFACE SURFACE / SUPERFICIE										VAP		
SCHNEIDSTOFF / MATERIAL MATIÈRE / MATERIALE										HSSE-PM		
ANSCHNITTFORM / CHAMFER FORM FORME D'ENTRÉE / FORMA D'IMBOCCO										C / 2-3		
d_1	- P/1"		NORM	l_1	l_2	l_3	d_2	a	2BX		3BX	
UNF NR 10	- 32	4,1	≈ 371	70	15	25	6	4,9	6614ABHAA		6614AB3AA	
UNF 1/4	- 28	5,5	≈ 371	80	17	30	7	5,5	6614ABJAA		6614AB5AA	
UNF 5/16	- 24	6,9	≈ 371	90	17	35	8	6,2	6614AA9AA		6614ACAAA	
UNF 3/8	- 24	8,5	≈ 371	90	18	35	10	8	6614ABAAA		6614ACBAA	

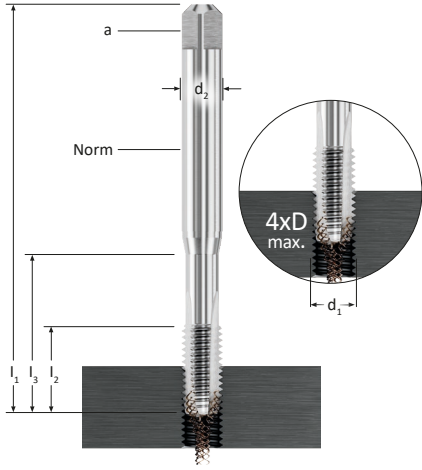

OBERFLÄCHE / SURFACE SURFACE / SUPERFICIE	NITVAP	-	-	VAP	TIN							
SCHNEIDSTOFF / MATERIAL MATIÈRE / MATERIALE	HSSE	HSSE	HSSE	HSSE-PM	HSSE-PM							
ANSCHNITTFORM / CHAMFER FORM FORME D'ENTRÉE / FORMA D'IMBOCCO	B / 4-5	B / 4-5	B / 4-5	B / 4-5	B / 4-5							
d_1 - P/1"	NORM	l_1	l_2	l_3	d_2	a	2B	2B	3B	2BX	2BX	
UNF NR 2 - 64	1,85	≈ 371	45	7	12	2,8	2,1					
UNF NR 4 - 48	2,4	≈ 371	56	11	18	3,5	2,7	6560ACLAA	6080ACRAA		6084A2067	6084A2076
UNF NR 5 - 44	2,7	≈ 371	56	11	18	3,5	2,7				6084A2068	6084A2077
UNF NR 6 - 40	2,95	≈ 371	56	12	20	4	3	6560ACNAA	6080ACTAA		6084A2069	6084A2078
UNF NR 8 - 36	3,5	≈ 371	63	13	21	4,5	3,4	6560ACPAA	6080ACUAA		6084A2070	6084A2079
UNF NR 10 - 32	4,1	≈ 371	70	15	25	6	4,9	6560ABCAA	6080ACVAA		6084A2071	6084A2080
UNF 1/4 - 28	5,5	≈ 371	80	17	30	7	5,5	6560ABBAA	6080ACXAA		6084A2072	6084A2081
		≈ 376	80	17	-	4,5	3,4		7080A2017			
UNF 5/16 - 24	6,9	≈ 371	90	17	35	8	6,2	6560A2429	6080A2018		6084A2073	6084A2082
		≈ 376	90	17	-	6	4,9		7080AF7AA			
UNF 3/8 - 24	8,5	≈ 371	90	18	35	10	8	6560F0052	6080A2020		6084A2074	6084A2083
		≈ 376	90	18	-	7	5,5		7080AF8AA			
UNF 7/16 - 20	9,9	≈ 376	100	22	-	8	6,2	7560AEZAA	7080AF9AA	7080A2105	7084A2089	7084A2094
UNF 1/2 - 20	11,5	≈ 376	100	22	-	9	7	7560AE0AA	7080AGAAA	7080A2106	7084A2075	7084A2084
UNF 9/16 - 18	12,9	≈ 376	100	22	-	11	9	7560AE1AA				
UNF 5/8 - 18	14,5	≈ 376	100	22	-	12	9	7560AE2AA	7080AGCAA	7080A2108		
UNF 3/4 - 16	17,5	≈ 376	110	25	-	14	11	7560AE3AA	7080AGDAA	7080A2109		
UNF 7/8 - 14	20,4	≈ 376	125	25	-	18	14,5	7560AE4AA	7080AGEAA			
UNF 1 - 12	23,25	≈ 376	140	28	-	18	14,5	7560AAMAA	7080AGFAA			
UNF 1 1/8 - 12	26,5	≈ 376	150	28	-	22	18	7560AE5AA	7080AGGAA			
UNF 1 1/4 - 12	29,5	≈ 376	150	28	-	22	18	7560AE6AA	7080AGHAA			
UNF 1 3/8 - 12	32,75	≈ 376	170	30	-	28	22	7560AE7AA	7080AGIAA			
UNF 1 1/2 - 12	36	≈ 376	170	30	-	28	22		7080AGJAA			

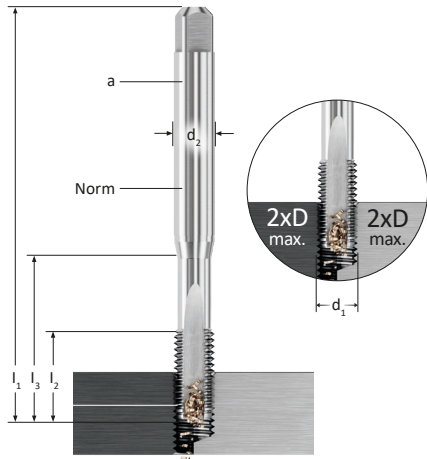

OBERFLÄCHE / SURFACE SURFACE / SUPERFICIE										NIT	
SCHNEIDSTOFF / MATERIAL MATIÈRE / MATERIALE										HSSE	
ANSCHNITTFORM / CHAMFER FORM FORME D'ENTRÉE / FORMA D'IMBOCCO										C / 2-3	
d_1	- P/1"	NORM	l_1	l_2	l_3	d_2	a			2BX	2BX
UNF NR 4	- 48	2,4	≈ 371	56	11	18	3,5	2,7		6103A1071	6200A1104
UNF NR 6	- 40	2,95	≈ 371	56	12	20	4	3		6103A1073	6200A1106
UNF NR 8	- 36	3,5	≈ 371	63	13	21	4,5	3,4		6103A1074	6200A1107
UNF NR 10	- 32	4,1	≈ 371	70	15	25	6	4,9		6103A1075	6200AA6AA
UNF 1/4	- 28	5,5	≈ 371	80	17	30	7	5,5		6103A1077	6200AA8AA
UNF 5/16	- 24	6,9	≈ 371	90	17	35	8	6,2		6103A1078	6200A1111
UNF 3/8	- 24	8,5	≈ 371	90	18	35	10	8		6103A1079	6200A1112
UNF 7/16	- 20	9,9	≈ 376	100	22	-	8	6,2		7103A1080	7200ACHAA
UNF 1/2	- 20	11,5	≈ 376	100	22	-	9	7		7103A1081	7200ACIAA
UNF 9/16	- 18	12,9	≈ 376	100	22	-	11	9		7103A1082	7200A1115
UNF 5/8	- 18	14,5	≈ 376	100	22	-	12	9		7103A1083	7200ACKAA
UNF 3/4	- 16	17,5	≈ 376	110	25	-	14	11		7103A1084	7200ACLAA
UNF 7/8	- 14	20,4	≈ 376	125	25	-	18	14,5		7103A1085	7200ACMAA
UNF 1	- 12	23,25	≈ 376	140	28	-	18	14,5		7103A1086	7200ACNAA

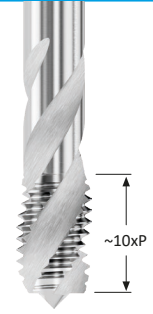

OBERFLÄCHE / SURFACE SURFACE / SUPERFICIE										-			
SCHNEIDSTOFF / MATERIAL MATIÈRE / MATERIALE										HSSE		HSSE	
ANSCHNITTFORM / CHAMFER FORM FORME D'ENTRÉE / FORMA D'IMBOCCO										B / 4-5		C / 2-3	
d_1	- P/1"		NORM	l_1	l_2	l_3	d_2	a	2B		2B		
UNEF	1/4	- 32	5,55	≈ 374	80	14	-	4,5	3,4	7080AHNAA		7640A3679	
UNEF	5/16	- 32	7,15	≈ 374	80	14	-	6	4,9	7080AHPAA		7640A3680	
UNEF	3/8	- 32	8,7	≈ 374	90	18	-	7	5,5	7080AHQAA		7640A3681	
UNEF	7/16	- 28	10,2	≈ 374	90	18	-	8	6,2	7080AHRAA		7640A3682	
UNEF	1/2	- 28	11,8	≈ 374	100	18	-	9	7	7080AHSAA		7640A3683	
UNEF	9/16	- 24	13,2	≈ 374	100	18	-	11	9	7080AHTAA		7640A3684	
UNEF	5/8	- 24	14,8	≈ 374	100	18	-	12	9	7080AHUAA		7640A3685	
UNEF	3/4	- 20	17,8	≈ 374	110	25	-	14	11	7080AHVAA		7640A3686	
UNEF	7/8	- 20	20,95	≈ 374	125	25	-	18	14,5	7080AHWAA		7640A3687	
UNEF	1	- 20	24,15	≈ 374	140	28	-	18	14,5	7080AHXAA		7640A3688	

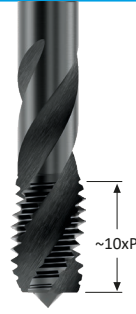
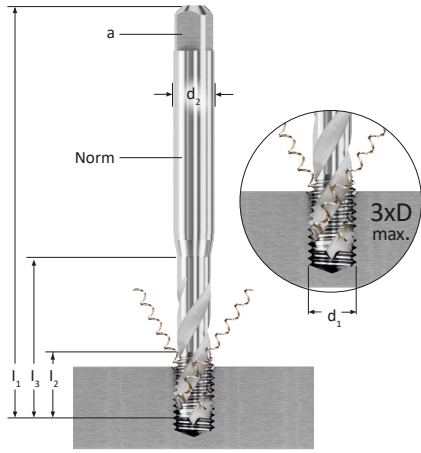

OBERFLÄCHE / SURFACE SURFACE / SUPERFICIE		VAP							
SCHNEIDSTOFF / MATERIAL MATIÈRE / MATERIALE		HSSE							
ANSCHNITTFORM / CHAMFER FORM FORME D'ENTRÉE / FORMA D'IMBOCCO		C / 2-3							
d_1	- P/1"		NORM						
l_1	l_2	l_3	d_2 a						
UN 1 1/8	- 8	25,4	≈ 374	180	30	-	22	18	7642AXQAA
UN 1 1/4	- 8	28,6	≈ 374	180	30	-	22	18	7642AXRAA
UN 1 1/2	- 8	35	≈ 374	200	30	-	28	22	7642AHSAA
UN 1 3/4	- 8	41,3	≈ 374	200	30	-	36	29	7642AXUAA
UN 2	- 8	47,7	≈ 374	225	33	-	40	32	7642AXWAA



SOLUTIONS@NORIS-REIME.DE

Das REIME Team steht Ihnen bei der Lösung Ihrer Zerspanungsaufgabe gerne zur Seite

The REIME team will be happy to solve your threading tasks

L'équipe de REIME se tient à votre disposition pour résoudre vos problèmes de filetage

Il team REIME sarà lieto di risolvere i vostri problemi di filettatura

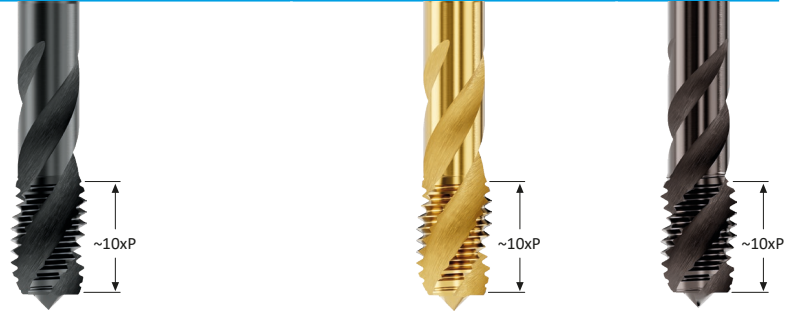
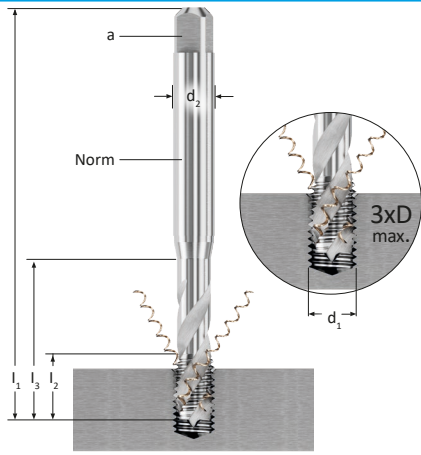

OBERFLÄCHE / SURFACE SURFACE / SUPERFICIE		VAP			TIN		ALTINHD							
SCHNEIDSTOFF / MATERIAL MATIÈRE / MATERIALE		HSSE			HSSE		HSSE							
ANSCHNITTFORM / CHAMFER FORM FORME D'ENTRÉE / FORMA D'IMBOCCO		C / 2-3	E / 1,5-2		C / 2-3	E / 1,5-2	E / 1,5-2							
d ₁	- P/1"		NORM	l ₁	l ₂	l ₃	d ₂	a	ISO 228 X	ISO 228 X	ISO 228 X +0,05 ¹⁾	ISO 228 X	ISO 228 X	ISO 228 X
G 1/16	- 28	6,8	DIN 5156	90	17	-	6	4,9	7642A3885					
G 1/8	- 28	8,8	DIN 5156	90	18	-	7	5,5	7642ACMAA	7642ACMAR	7642A4454	7642ACMAB	7642ACMAS	7470F0056
G 1/4	- 19	11,8	DIN 5156	100	22	-	11	9	7642ACNAA	7642ACNAM	7642A4455	7642ACNAB	7642ACNAN	7470F0057
G 3/8	- 19	15,25	DIN 5156	100	22	-	12	9	7642ACPAA	7642ACPAM	7642A4456	7642ACPAC	7642ACPAN	7470F0058
G 1/2	- 14	19	DIN 5156	125	25	-	16	12	7642ACQAA	7642ACQAS	7642A4457	7642ACQAB	7642ACQAI	7470F0059
G 5/8	- 14	21	DIN 5156	125	25	-	18	14,5	7642ACRAA					
G 3/4	- 14	24,5	DIN 5156	140	28	-	20	16	7642ACSAA		7642A4459			
G 7/8	- 14	28,25	DIN 5156	150	28	-	22	18	7642ACTAA					
G 1	- 11	30,75	DIN 5156	160	30	-	25	20	7642ACUAA		7642A4460			
G 1 1/8	- 11	35,5	DIN 5156	170	30	-	28	22	7642ACVAA					
G 1 1/4	- 11	39,5	DIN 5156	170	30	-	32	24	7642ACWAA					
G 1 3/8	- 11	41,75	DIN 5156	180	32	-	36	29	7642ACXAA					
G 1 1/2	- 11	45,25	DIN 5156	190	32	-	36	29	7642ACYAA					
G 1 5/8	- 11	49,5	DIN 5156	190	32	-	40	32						
G 1 3/4	- 11	51	DIN 5156	190	32	-	40	32						

1) - Ø + 0,05 mm

NORIS SALOREX

ST

VA

VR

NW

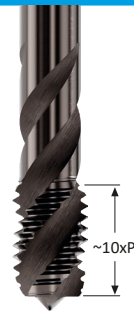

-	VAP	ALTiNHd	TiBLU		DLC	
HSSE	HSSE	HSSE	HSSE-PM		HSSE	
C / 2-3	E / 1,5-2	E / 1,5-2	C / 2-3	E / 1,5-2	C / 2-3	
ISO 228 X	ISO 228 X	ISO 228 X	ISO 228 X	ISO 228 X	ISO 228 X	d ₁ - P/1"
7640AB8AA	7645AA6AA	7645F0025	7655K00189	7655K00229	7641F0099	G 1/16 - 28
7640AB9AA	7645ABDAA	7645F0026	7655K00188	7655K00228	7641F0100	G 1/4 - 19
7640ACAAA	7645ABVAA	7645F0027	7655K00191	7655K00231	7641F0101	G 3/8 - 19
7640ACBAA	7645ABSAA	7645F0028	7655K00187	7655K00227	7641F0102	G 1/2 - 14
	7645AA3AA					G 5/8 - 14
7640ACDAA	7645ABPAA		7655K00190	7655K00230	7641F0103	G 3/4 - 14
						G 7/8 - 14
7640ACFAA	7645ABGAA		7655K00186	7655K00226	7641F0104	G 1 - 11
7640ACGAA						G 1 1/8 - 11
7640ACHAA						G 1 1/4 - 11
7640ACIAA						G 1 3/8 - 11
7640ACJAA						G 1 1/2 - 11
7640A3595						G 1 5/8 - 11
7640ACKAA						G 1 3/4 - 11

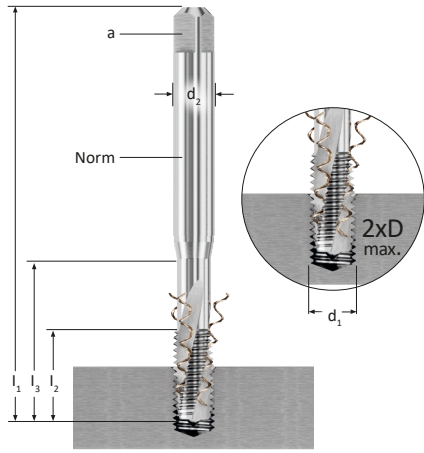

OBERFLÄCHE / SURFACE SURFACE / SUPERFICIE										-
SCHNEIDSTOFF / MATERIAL MATIÈRE / MATERIALE										HSSE
ANSCHNITTFORM / CHAMFER FORM FORME D'ENTRÉE / FORMA D'IMBOCCO										C / 2-3
d_1	- P/1"		NORM	l_1	l_2	l_3	d_2	a		ISO 228 X
G 1/8	- 28	8,8	DIN 5156	90	18	-	7	5,5		7600AF9AA
G 1/4	- 19	11,8	DIN 5156	100	22	-	11	9		7600AGAAA
G 3/8	- 19	15,25	DIN 5156	100	22	-	12	9		7600AGBAA
G 1/2	- 14	19	DIN 5156	125	25	-	16	12		7600AGCAA
G 3/4	- 14	24,5	DIN 5156	140	28	-	20	16		7600AGEAA
G 1	- 11	30,75	DIN 5156	160	30	-	25	20		7600AGGAA
G 1 1/8	- 11	35,5	DIN 5156	170	30	-	28	22		7600A3282
G 1 1/4	- 11	39,5	DIN 5156	170	30	-	32	24		7600AGIAA
G 1 3/8	- 11	41,75	DIN 5156	180	32	-	36	29		7600AGJAA
G 1 1/2	- 11	45,25	DIN 5156	190	32	-	36	29		7600AGKAA

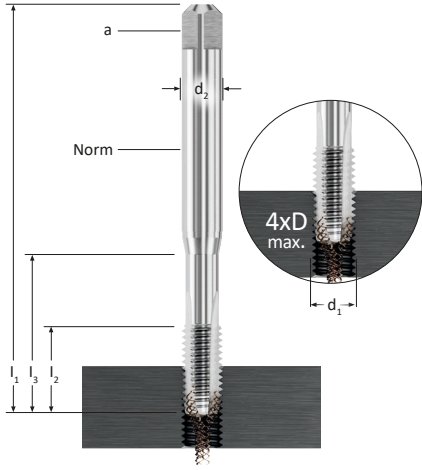

OBERFLÄCHE / SURFACE SURFACE / SUPERFICIE	NITVAP	TIN	-	NIT	DLC
SCHNEIDSTOFF / MATERIAL MATIÈRE / MATERIALE	HSSE	HSSE	HSSE	HSSE	HSSE
ANSCHNITTFORM / CHAMFER FORM FORME D'ENTRÉE / FORMA D'IMBOCCO	B / 4-5	B / 4-5	B / 4-5	B / 4-5	B / 4-5
d_1 - P/1" NORM l_1 l_2 l_3 d_2 a	ISO 228 X	ISO 228 X	ISO 228 X	ISO 228 X	ISO 228 X
G 1/8 - 28 8,8 DIN 5156 90 18 - 7 5,5	7560AD0AA	7560A2248	7080AEYAA	7535ABNAA	7571F0053
G 1/4 - 19 11,8 DIN 5156 100 22 - 11 9	7560AAEAB	7560A2249	7080AEZAA	7535ABPAA	7571F0054
G 3/8 - 19 15,25 DIN 5156 100 22 - 12 9	7560AD1AA	7560A2250	7080AE0AA	7535ABQAA	7571F0055
G 1/2 - 14 19 DIN 5156 125 25 - 16 12	7560AAFAB	7560A2251	7080AE1AA	7535ABRAA	7571F0056
G 3/4 - 14 24,5 DIN 5156 140 28 - 20 16	7560AD3AA		7080AE3AA	7535ABTAA	7571F0057
G 1 - 11 30,75 DIN 5156 160 30 - 25 20	7560AD5AA		7080AE5AA	7535ABVAA	7571F0058
G 1 1/8 - 11 35,5 DIN 5156 170 30 - 28 22			7080AE6AA		
G 1 1/4 - 11 39,5 DIN 5156 170 30 - 32 24			7080AE7AA		
G 1 3/8 - 11 41,75 DIN 5156 180 32 - 36 29			7080AE8AA		
G 1 1/2 - 11 45,25 DIN 5156 190 32 - 36 29			7080AE9AA		
G 1 5/8 - 11 49,5 DIN 5156 190 32 - 40 32			7080A1921		
G 1 3/4 - 11 51 DIN 5156 190 32 - 40 32			7080AFAAA		

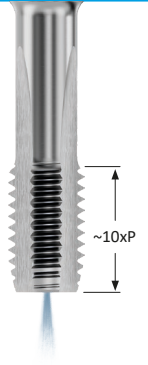
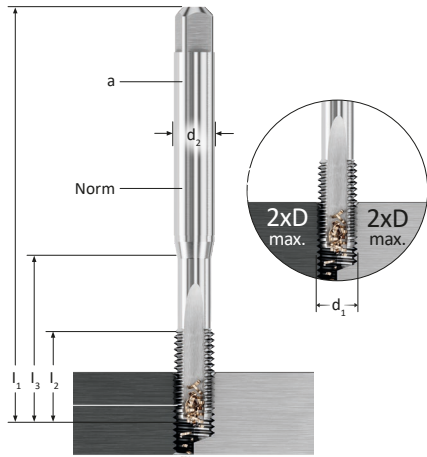

OBERFLÄCHE / SURFACE SURFACE / SUPERFICIE										-	NIT	TICN	-
SCHNEIDSTOFF / MATERIAL MATIÈRE / MATERIALE										HSSE	HSSE	HSSE	HM
ANSCHNITTFORM / CHAMFER FORM FORME D'ENTRÉE / FORMA D'IMBOCCO										C / 2-3	C / 2-3	C / 2-3	E / 1,5-2
d ₁	- P/1"	NORM	l ₁	l ₂	l ₃	d ₂	a	ISO 228 X	ISO 228 X	ISO 228 X	ISO 228 X		
G 1/16	- 28	6,8	DIN 5156	90	17	-	6	4,9	7100AGRAA				
			DIN 5157	63	18	-	7	5,5					
			≈ DIN 371	90	18	35	10	8					
			DIN 5156	90	18	-	7	5,5	7100AFFAA	7103A1034	7103B0451	7300B0740	
			DIN 5157	70	20	-	11	9					
			≈ DIN 371	110	24	44	14	11					
			DIN 5156	100	22	-	11	9	7100AFGAA	7103A1035	7103B0452	7300B0741	
G 1/8	- 28	8,8	DIN 5157	70	20	-	12	9					
			DIN 5156	100	22	-	12	9	7100AFHAA	7103A1036	7103B0453	7300B0742	
			DIN 5157	80	22	-	16	12					
			DIN 5156	125	25	-	16	12	7100AFIAA	7103A1037	7103B0454	7300B0743	
G 1/4	- 19	11,8	DIN 5157	90	22	-	20	16					
			DIN 5156	140	28	-	20	16	7100AFKAA	7103A1039	7103D00276		
			DIN 5157	100	25	-	25	20					
			DIN 5156	160	30	-	25	20	7100AFMAA	7103A1041	7103D00277		
G 1 1/8	- 11	35,5	DIN 5156	170	30	-	28	22	7100AFNAA	7103A1042			
			DIN 5157	125	30	-	32	24					
G 1 1/4	- 11	39,5	DIN 5156	170	30	-	32	24	7100AFPAA	7103A1043			
			DIN 5156	180	32	-	36	29	7100AFQAA	7103A1044			
			DIN 5157	140	30	-	36	29					
G 1 1/2	- 11	45,25	DIN 5156	190	32	-	36	29	7100AFRAA	7103A1045			
			DIN 5156	190	32	-	40	32	7100A1272				
G 1 5/8	- 11	49,5	DIN 5156	190	32	-	40	32					
G 1 3/4	- 11	51	DIN 5156	190	32	-	40	32		7103A1046			
G 2	- 11	57	DIN 5156	220	40	-	45	35		7103D00285			

GG



NORIS TWIN
MS

HT



AUT

NIT	TICN	-	-	-	TICN	ALTIN	
HSSE	HSSE	HSSE	HSSE	HSSE	HSSE-PM	HM	
C / 2-3	C / 2-3	ekA / 1 max.	ekA / 1 max.	ekA / 1 max.	C / 2-3	D / 4-5	
ISO 228 X	ISO 228 X	ISO 228 X	ISO 228 X +0,05 ¹⁾	ISO 228 X +0,1 ²⁾	ISO 228 X	ISO 228 X	d ₁ x P/1"
		5250F0074	5250F0053	5250F0059			G 1/16 - 28
7200ABVAA	7200B0471				710HF0008	6260AAGAA	G 1/8 - 28
		5250F0073	5250F0054	5250F0060			
7200ABWAA	7200B0472				710HF0007	6260E2188	G 1/4 - 19
		5250F0080	5250F0055	5250F0061			
7200ABXAA	7200B0473				710HF0009		G 3/8 - 19
		5250F0081	5250F0056	5250F0062			
7200ABYAA	7200B0474				710HF0010		G 1/2 - 14
		5250F0082	5250F0057	5250F0063			
7200AB0AA							G 3/4 - 14
		5250F0083	5250F0058	5250F0064			
7200AB2AA							G 1 - 11
7200A1429							G 1 1/8 - 11
		5250F0099					G 1 1/4 - 11
7200AB3AA							G 1 1/4 - 11
7200A1431							G 1 3/8 - 11
		5250F0098					G 1 1/2 - 11
7200AB4AA							G 1 1/2 - 11
							G 1 5/8 - 11
							G 1 3/4 - 11
							G 2 - 11

1)  - $\varnothing + 0,05$ mm2)  - $\varnothing + 0,10$ mm

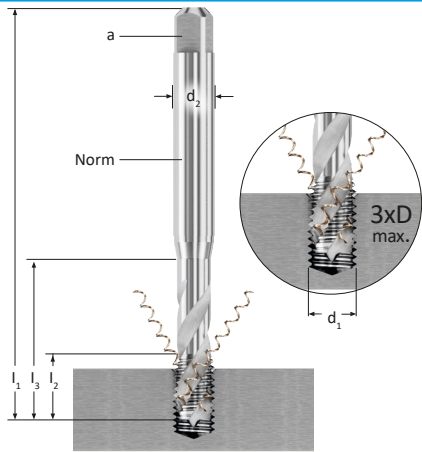

OBERFLÄCHE / SURFACE SURFACE / SUPERFICIE										VAP	
SCHNEIDSTOFF / MATERIAL MATIÈRE / MATERIALE										HSSE	
ANSCHNITTFORM / CHAMFER FORM FORME D'ENTRÉE / FORMA D'IMBOCCO										E / 1,5-2	
d_1	- P/1"		NORM	l_1	l_2	l_3	d_2	a			
RP 1/8	- 28	8,6	DIN 5156	90	18	-	7	5,5	7642A1911		
RP 1/4	- 19	11,5	DIN 5156	100	22	-	11	9	7642A1910		
RP 3/8	- 19	15	DIN 5156	100	22	-	12	9	7642A1909		
RP 1/2	- 14	18,5	DIN 5156	125	25	-	16	12	7642A1908		
RP 3/4	- 14	24	DIN 5156	140	28	-	20	16	7642A1907		
RP 1	- 11	30,25	DIN 5156	160	30	-	25	20	7642A1906		

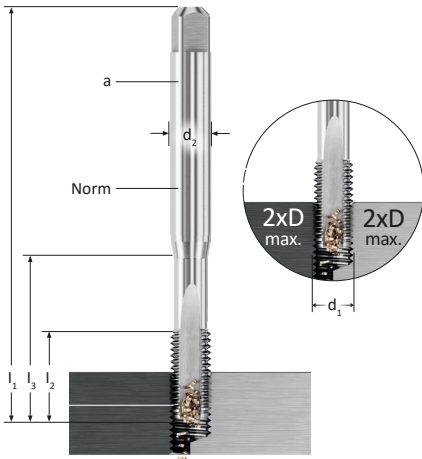

OBERFLÄCHE / SURFACE SURFACE / SUPERFICIE										-	-	TICN	-	-
SCHNEIDSTOFF / MATERIAL MATIÈRE / MATERIALE										HSSE	HSSE	HSSE	HSSE	HSSE
ANSCHNITTFORM / CHAMFER FORM FORME D'ENTRÉE / FORMA D'IMBOCCO										C / 2-3	C / 2-3	C / 2-3	ekA / 1 max.	ekA / 1 max.
d ₁	P/1"		NORM	l ₁	l ₂	l ₃	d ₂	a		X	X	X	X	X +0,05 ¹⁾
RP	1/8	- 28	8,6	DIN 5156	90	18	-	7	5,5	7100AFYAA				
RP	1/4	- 19	11,5	≈ DIN 352 DIN 5156	70 100	20 22	-	10 11	8 9	7100AFZAA			5250F0205	5250F0210
RP	3/8	- 19	15	≈ DIN 352 DIN 5156	70 100	20 22	-	12 12	9 9	7100AF0AA			5250F0206	5250F0211
RP	1/2	- 14	18,5	≈ DIN 352 DIN 5156	80 125	22 25	-	15 16	12 12	7100AF1AA			5250F0207	5250F0212
RP	3/4	- 14	24	≈ DIN 352 DIN 5156	90 140	22 28	-	18 20	14,5 16	7100AF2AA			5250F0208	5250F0213
RP	1	- 11	30,25	≈ DIN 352 DIN 5156	100 160	25 30	-	18 25	14,5 20	7100AF3AA			5250F0209	5250F0214
RC	1/8	- 28	- ²⁾	≈ DIN 2181 ≈ DIN 371	63 90	12 12		7 26	5,5 8	5100A1925		6102F0007	6103D00286	
RC	1/4	- 19	- ²⁾	≈ DIN 2181 ≈ DIN 374	63 100	18 18		11 34,5	9 14	5100A1924		6102F0008 7102F0020	6103D00287 7103D00288	
RC	3/8	- 19	- ²⁾	≈ DIN 2181 ≈ DIN 374	70 110	18 18		12 14	9 11	5100A1923		7102F0021	7103D00289	
RC	1/2	- 14	- ²⁾	≈ DIN 2181 ≈ DIN 374	80 140	23 23		16 16	12 12	5100A1922		7102F0022	7103D00290	
RC	3/4	- 14	- ²⁾	≈ DIN 2181 ≈ DIN 374	100 150	24 24		20 20	16 16	5100A1921			7103D00291	
RC	1	- 11	- ²⁾	≈ DIN 2181 ≈ DIN 374	110 170	30 30		25 25	20 20	5100A1920			7103D00292	

1) - Ø + 0,05 mm

2) Gewinde-Kernlochdurchmesser-Tabelle => Seite 238
Threaded Core Hole Diameter Table => Page 238
Tableau des diamètres des trous de filetage => Page 238
Tabella dei diametri dei fori filettati => Pagina 238

BSW BS 84

NORIS STABIL UNI

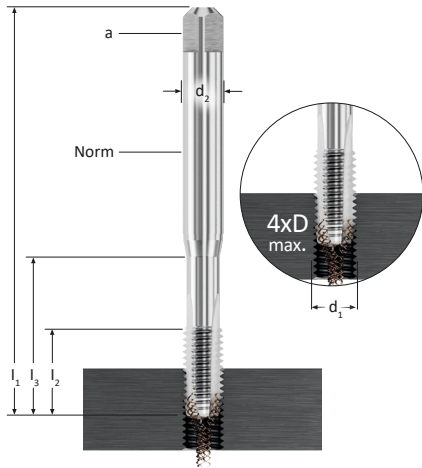

BSW BS 84

NORIS SALOREX UNI

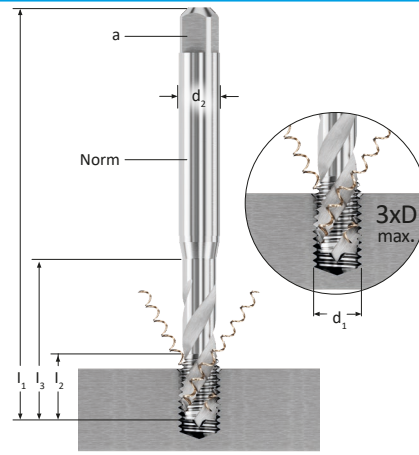

OBERFLÄCHE / SURFACE SURFACE / SUPERFICIE										NITVAP	
SCHNEIDSTOFF / MATERIAL MATIÈRE / MATERIALE										HSSE	
ANSCHNITTFORM / CHAMFER FORM FORME D'ENTRÉE / FORMA D'IMBOCCO										B / 4-5	
d_1	- P/1"		NORM	l_1	l_2	l_3	d_2	a	MED		
BSW 1/8	- 40	2,55	≈ DIN 371	56	11	18	3,5	2,7	6560ABUAA		
BSW 3/16	- 24	3,7	≈ DIN 371	70	15	25	6	4,9	6560ABWAA		
BSW 1/4	- 20	5,1	≈ DIN 371	80	17	30	7	5,5	6560ABXAA		
BSW 5/16	- 18	6,5	≈ DIN 371	90	20	35	8	6,2	6560ABYAA		
BSW 3/8	- 16	7,9	≈ DIN 371	100	22	39	10	8	6560ABZAA		
BSW 7/16	- 14	9,25	≈ DIN 376	100	22	-	8	6,2	7560F0037		
BSW 1/2	- 12	10,5	≈ DIN 376	110	25	-	9	7	7560AEMAA		
BSW 5/8	- 11	13,5	≈ DIN 376	110	27	-	12	9	7560AENAA		
BSW 3/4	- 10	16,4	≈ DIN 376	125	30	-	14	11	7560AEPAA		
BSW 1	- 8	22	≈ DIN 376	160	36	-	18	14,5	7560AERAA		

OBERFLÄCHE / SURFACE SURFACE / SUPERFICIE										VAP	
SCHNEIDSTOFF / MATERIAL MATIÈRE / MATERIALE										HSSE	
ANSCHNITTFORM / CHAMFER FORM FORME D'ENTRÉE / FORMA D'IMBOCCO										C / 2-3	
d_1	- P/1"		NORM	l_1	l_2	l_3	d_2	a	MED		
BSW 1/8	- 40	2,55	≈ DIN 371	56	11	18	3,5	2,7	6642AB6AA		
BSW 3/16	- 24	3,7	≈ DIN 371	70	15	25	6	4,9	6642AB7AA		
BSW 1/4	- 20	5,1	≈ DIN 371	80	17	30	7	5,5	6642AB8AA		
BSW 5/16	- 18	6,5	≈ DIN 371	90	20	35	8	6,2	6642AB9AA		
BSW 3/8	- 16	7,9	≈ DIN 371	100	22	39	10	8	6642ACAAA		
BSW 7/16	- 14	9,25	≈ DIN 376	100	22	-	8	6,2	7642A3906		
BSW 1/2	- 12	10,5	≈ DIN 376	110	25	-	9	7	7642ACHAA		
BSW 5/8	- 11	13,5	≈ DIN 376	110	27	-	12	9	7642ACIAA		
BSW 3/4	- 10	16,4	≈ DIN 376	125	30	-	14	11	7642ACJAA		
BSW 1	- 8	22	≈ DIN 376	160	36	-	18	14,5	7642ACLAA		

BSF BS 84

NORIS TWIN ST

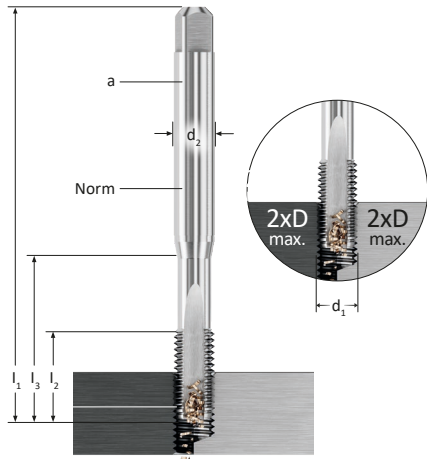

OBERFLÄCHE / SURFACE SURFACE / SUPERFICIE										-	
SCHNEIDSTOFF / MATERIAL MATIÈRE / MATERIALE										HSSE	
ANSCHNITTFORM / CHAMFER FORM FORME D'ENTRÉE / FORMA D'IMBOCCO										C / 2-3	
d_1	- P/1"		NORM	l_1	l_2	l_3	d_2	a	MED-X		
BSF 1/4	- 26	5,3	≈ DIN 371	80	17	30	7	5,5	6100A1322		
BSF 5/16	- 22	6,8	≈ DIN 371	90	17	35	8	6,2	6100A1323		
BSF 3/8	- 20	8,3	≈ DIN 371	100	18	39	10	8	6100A1324		
BSF 7/16	- 18	9,7	≈ DIN 376	100	22	-	8	6,2	7100A1325		
BSF 1/2	- 16	11,1	≈ DIN 376	110	22	-	9	7	7100A1326		
BSF 5/8	- 14	14,0	≈ DIN 376	110	27	-	12	9	7100A1327		
BSF 3/4	- 12	16,75	≈ DIN 376	125	27	-	14	11	7100A1328		
BSF 1	- 10	22,75	≈ DIN 376	160	36	-	18	14,5	7100A1330		



SOLUTIONS@NORIS-REIME.DE

Das REIME Team steht Ihnen bei der Lösung Ihrer Zerspanungsaufgabe gerne zur Seite

The REIME team will be happy to solve your threading tasks

L'équipe de REIME se tient à votre disposition pour résoudre vos problèmes de filetage

Il team REIME sarà lieto di risolvere i vostri problemi di filettatura

NPT | NPTF

ST

NORIS TWIN

VG

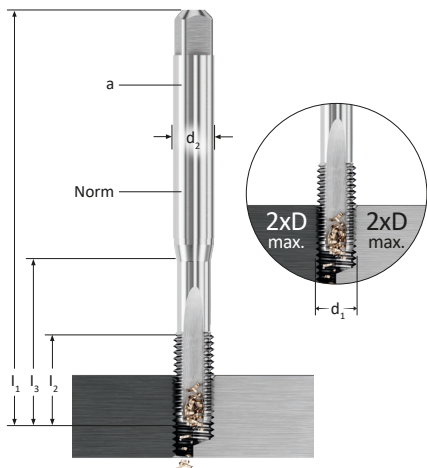

OBERFLÄCHE / SURFACE SURFACE / SUPERFICIE		-	-	-	-							
SCHNEIDSTOFF / MATERIAL MATIÈRE / MATERIALE		HSSE	HSSE	HSSE	HSSE							
ANSCHNITTFORM / CHAMFER FORM FORME D'ENTRÉE / FORMA D'IMBOCCO		C / 2-3	C / 2-3	C / 2-3	C / 2-3							
d_1	- P/1"	NORM	l_1	l_2	l_3	d_2	a					
NPT	1/16 - 27	≈ DIN 2181 ≈ DIN 371	63 90	12 12	- 26	6 8	4,9 6,2	5100AAAA 6100A1732			6102A1884	6112A1888
NPT	1/8 - 27	≈ DIN 2181 ≈ DIN 371	63 90	12 12	- 26	7 10	5,5 8	5100AABAA 6100A1733	5110AABAA		6102A1885	6112A1887
NPT	1/4 - 18	≈ DIN 2181 ≈ DIN 371	63 100	18 18	- 34,5	11 14	9 11	5100AACAA 6100F0007	5110AACAA		6102A1886	6112A1898
NPT	3/8 - 18	≈ DIN 2181 ≈ DIN 374	70 110	18 18	- 14	12 11	9 11	5100AADAA 7100AIGAB	5110AADAA		7102A1890	7112A1896
NPT	1/2 - 14	≈ DIN 2181 ≈ DIN 374	80 140	23 23	- 16	12 12	12 12	5100AAEAA 7100AIEAH	5110AAEAA		7102A1891	7112A1893
NPT	3/4 - 14	≈ DIN 2181 ≈ DIN 374	100 150	24 24	- 20	16 16	16 16	5100AAFAA 7100AIFAE	5110AAFAA		7102A1892	7112A1894
NPT	1 - 11,5	≈ DIN 2181 ≈ DIN 374	110 170	30 30	- 25	20 20	20 20	5100AAGAA 7100AIHAD	5110AAGAA		7102A1889	7112A1895
NPTF	1/16 - 27	≈ DIN 2181 ≈ DIN 371	63 90	12 12	- 26	6 8	4,9 6,2	5100AAKAA 6100A1740			6102A1899	
NPTF	1/8 - 27	≈ DIN 2181 ≈ DIN 371	63 90	12 12	- 26	7 10	5,5 8	5100AALAA 6100A1741			6102A1900	
NPTF	1/4 - 18	≈ DIN 2181 ≈ DIN 371	63 100	18 18	- 34,5	11 14	9 11	5100AAMAA 6100A1742			6102A1901	
NPTF	3/8 - 18	≈ DIN 2181 ≈ DIN 374	70 110	18 18	- 14	12 11	9 11	5100AANAA 7100A1743			7102A1905	
NPTF	1/2 - 14	≈ DIN 2181 ≈ DIN 374	80 140	23 23	- 16	12 12	12 12	5100AAPAA 7100A1744			7102A1904	
NPTF	3/4 - 14	≈ DIN 2181 ≈ DIN 374	100 150	24 24	- 20	16 16	16 16	5100AAQAA 7100A1745			7102A1903	
NPTF	1 - 11,5	≈ DIN 374	170	30	-	25	20	7100A1746			7102A1902	

1) Gewinde-Kernlochdurchmesser-Tabelle => NPT Seite 240 | NPTF Seite 242
 Threaded Core Hole Diameter Table => NPT Page 240 | NPTF Page 242
 Tableau des diamètres des trous de filetage => NPT Page 240 | NPTF Page 242
 Tabella dei diametri dei fori filettati => NPT Pagina 240 | NPTF Pagina 242

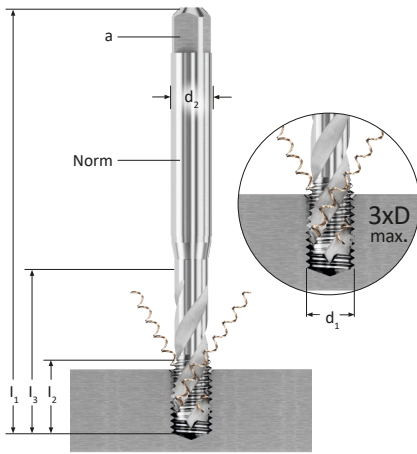

OBERFLÄCHE / SURFACE SURFACE / SUPERFICIE		VAP		TIN					
SCHNEIDSTOFF / MATERIAL MATIÈRE / MATERIALE		HSSE		HSSE					
ANSCHNITTFORM / CHAMFER FORM FORME D'ENTRÉE / FORMA D'IMBOCCO		C / 2-3		E / 1,5-2					
d_1	- P/1"	NORM	l_1	l_2	l_3	d_2	a		
NPT	1/16 - 27	≈ DIN 371	90	12	26	8	6,2	6605AAHAA	
NPT	1/8 - 27	≈ DIN 371	90	12	26	10	8	6605AAIAA	6645AFGAA
NPT	1/4 - 18	≈ DIN 371	100	18	34,5	14	11	6605AAJAA	6645AFHAA
NPT	3/8 - 18	≈ DIN 374	110	18	-	14	11	7605F0001	7645A1950
NPT	1/2 - 14	≈ DIN 374	140	23	-	16	12	7605F0003	7645A1951
NPT	3/4 - 14	≈ DIN 374	150	24	-	20	16	7605A5086	
NPT	1 - 11,5	≈ DIN 374	170	30	-	25	20	7605A5088	
NPTF	1/16 - 27	≈ DIN 371	90	12	26	8	6,2	6605AANAA	
NPTF	1/8 - 27	≈ DIN 371	90	12	26	10	8	6605AAPAA	
NPTF	1/4 - 18	≈ DIN 371	100	18	34,5	14	11	6605AAQAA	
NPTF	3/8 - 18	≈ DIN 374	110	18	-	14	11	7605A5096	
NPTF	1/2 - 14	≈ DIN 374	140	23	-	16	12	7605A5098	
NPTF	3/4 - 14	≈ DIN 374	150	24	-	20	16	7605A5099	

1) Gewinde-Kernlochdurchmesser-Tabelle => NPT Seite 240 | NPTF Seite 242
 Threaded Core Hole Diameter Table => NPT Page 240 | NPTF Page 242
 Tableau des diamètres des trous de filetage => NPT Page 240 | NPTF Page 242
 Tabella dei diametri dei fori filettati => NPT Pagina 240 | NPTF Pagina 242

NPSM | NPSF

NORIS
TWIN ST

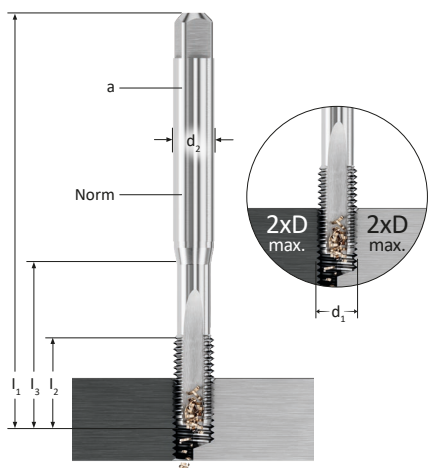

NPSM | NPSF

NORIS
SALOREX UNI

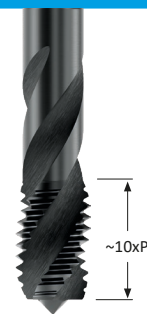
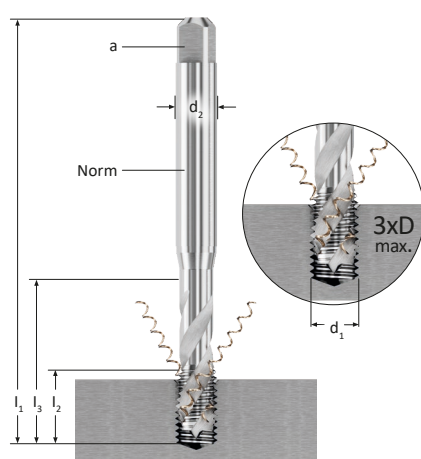

OBERFLÄCHE / SURFACE SURFACE / SUPERFICIE			
SCHNEIDSTOFF / MATERIAL MATIÈRE / MATERIALE		HSSE	
ANSCHNITTFORM / CHAMFER FORM FORME D'ENTRÉE / FORMA D'IMBOCCO		C / 2-3	
d ₁	- P/1"	NORM	X
NPSM 1/8	- 27	9,1 ≈ DIN 5156	7100AF7AA
NPSM 1/4	- 18	12 ≈ DIN 5156	7100AF8AA
NPSM 3/8	- 18	15,5 ≈ DIN 5156	7100AGEAA
NPSM 1/2	- 14	19 ≈ DIN 5156	7100AGFAA
NPSM 3/4	- 14	24,5 ≈ DIN 5156	7100AGDAA
NPSM 1	- 11,5	30,5 ≈ DIN 5156	7100AF9AA
X			
NPSF 1/16	- 27	6,35 ≈ DIN 5156	7100A1308
NPSF 1/8	- 27	8,7 ≈ DIN 5156	7100A1309
NPSF 1/4	- 18	11,3 ≈ DIN 5156	7100A1310
NPSF 3/8	- 18	14,75 ≈ DIN 5156	7100A1311
NPSF 1/2	- 14	18,2 ≈ DIN 5156	7100A1312
NPSF 3/4	- 14	23,5 ≈ DIN 5156	7100A1313
NPSF 1	- 11,5	29,5 ≈ DIN 5156	7100A1314

OBERFLÄCHE / SURFACE SURFACE / SUPERFICIE		VAP	
SCHNEIDSTOFF / MATERIAL MATIÈRE / MATERIALE		HSSE	
ANSCHNITTFORM / CHAMFER FORM FORME D'ENTRÉE / FORMA D'IMBOCCO		E / 1,5-2	
d ₁	- P/1"	NORM	-
NPSM 1/8	- 27	9,1 ≈ DIN 5156	7642A1937
NPSM 1/4	- 18	12 ≈ DIN 5156	7642A1938
NPSM 3/8	- 18	15,5 ≈ DIN 5156	7642A1939
NPSM 1/2	- 14	19 ≈ DIN 5156	7642A1940
NPSM 3/4	- 14	24,5 ≈ DIN 5156	7642A1941
NPSM 1	- 11,5	30,5 ≈ DIN 5156	
-			
NPSF 1/16	- 27	6,35 ≈ DIN 5156	7642A1931
NPSF 1/8	- 27	8,7 ≈ DIN 5156	7642A1932
NPSF 1/4	- 18	11,3 ≈ DIN 5156	7642A1933
NPSF 3/8	- 18	14,75 ≈ DIN 5156	7642A1934
NPSF 1/2	- 14	18,2 ≈ DIN 5156	7642A1935
NPSF 3/4	- 14	23,5 ≈ DIN 5156	
NPSF 1	- 11,5	29,5 ≈ DIN 5156	

NPSM auch für NPSC und NPS verwendbar | NPSM also suitable for NPSC and NPS | NPSM convient également pour NPSC et NPS | NPSM adatto anche per NPSC e NPS

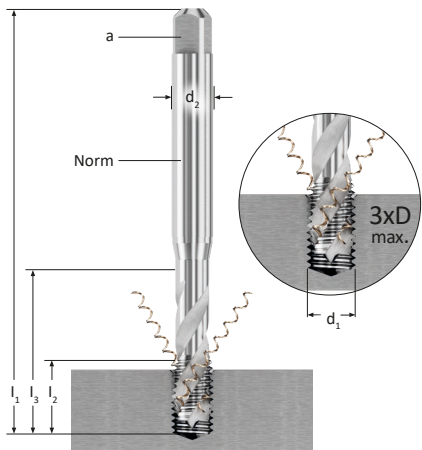

OBERFLÄCHE / SURFACE SURFACE / SUPERFICIE										DLC	
SCHNEIDSTOFF / MATERIAL MATIÈRE / MATERIALE										HSSE	
ANSCHNITTFORM / CHAMFER FORM FORME D'ENTRÉE / FORMA D'IMBOCCO										C / 2-3	
d_1	x	P		NORM	l_1	l_2	l_3	d_2	a	ISO1	
MJ	3	x	0,5	2,6	DIN 371	56	5	18	3,5	2,7	664SS0523511
MJ	4	x	0,7	3,4	DIN 371	63	7	21	4,5	3,4	664SS0523512
MJ	5	x	0,8	4,3	DIN 371	70	8	25	6	4,9	664SS0523513
MJ	6	x	1	5,1	DIN 371	80	10	30	6	4,9	664SS0523515
MJ	8	x	1	7,1	DIN 371	90	10	35	8	6,2	664SS0523516
MJ	8	x	1,25	6,9	DIN 371	90	14	35	8	6,2	664SS0523518
MJ	10	x	1,25	8,9	DIN 371	100	14	39	10	8	664SS0523520
d_1	- P/1"			NORM	l_1	l_2	l_3	d_2	a	3B	
UNJC	NR 4	-	40	2,3	≈ DIN 371	56	6	18	3,5	2,7	664SF0004
UNJC	NR 6	-	32	2,85	≈ DIN 371	56	7	20	4	3	664SF0005
UNJC	NR 8	-	32	3,5	≈ DIN 371	63	8	21	4,5	3,4	664SF0006
UNJC	NR 10	-	24	3,9	≈ DIN 371	70	10	25	6	4,9	664SF0007
UNJC	1/4	-	20	5,25	≈ DIN 371	80	13	30	7	5,5	664SF0008
UNJC	5/16	-	18	6,7	≈ DIN 371	90	14	35	8	6,2	664SF0009
d_1	- P/1"			NORM	l_1	l_2	l_3	d_2	a	3B	
UNJF	NR 4	-	48	2,4	≈ DIN 371	56	6	18	3,5	2,7	664SF0010
UNJF	NR 6	-	40	3	≈ DIN 371	56	7	20	4	3	664SF0011
UNJF	NR 8	-	36	3,55	≈ DIN 371	63	8	21	4,5	3,4	664SF0012
UNJF	NR 10	-	32	4,15	≈ DIN 371	70	10	25	6	4,9	664SF0013
UNJF	1/4	-	28	5,55	≈ DIN 371	80	13	30	7	5,5	664SF0014
UNJF	5/16	-	24	7	≈ DIN 371	90	14	35	8	6,2	664SF0015

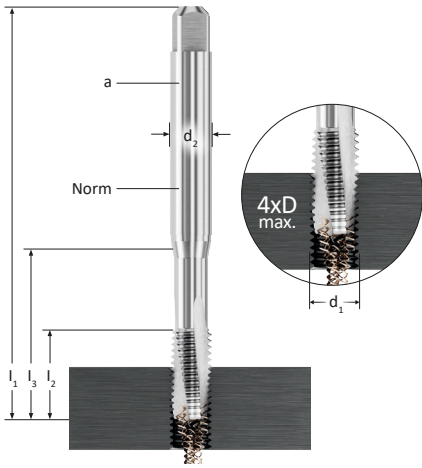

OBERFLÄCHE / SURFACE SURFACE / SUPERFICIE										TICN		TICN		
SCHNEIDSTOFF / MATERIAL MATIÈRE / MATERIALE										HSSE		HSSE-PM		
ANSCHNITTFORM / CHAMFER FORM FORME D'ENTRÉE / FORMA D'IMBOCCO										D / 4-5		D / 4-5		
										ISO1X		ISO1X		
MJ	3	x	0,5	2,6	DIN 371	56	11	18	3,5	2,7	6504A1848		6507B0082	
MJ	4	x	0,7	3,4	DIN 371	63	13	21	4,5	3,4	6504A1849		6507B0083	
MJ	5	x	0,8	4,3	DIN 371	70	15	25	6	4,9	6504A1850		6507B0084	
MJ	6	x	1	5,1	DIN 371	80	17	30	6	4,9	6504A1851		6507B0085	
MJ	8	x	1	7,1	DIN 371	90	17	35	8	6,2	6504A1852		6507B0086	
MJ	8	x	1,25	6,9	DIN 371	90	20	35	8	6,2	6504A1854		6507B0088	
MJ	10	x	1,25	8,9	DIN 371	100	18	39	10	8	6504A1853		6507B0087	
MJ	10	x	1,25	8,9	DIN 371	100	22	39	10	8	6504A1855		6507B0089	
										3BX		3BX		
UNJC	NR 4	-	40	2,3	≈ DIN 371	56	11	18	3,5	2,7	6504B0102		6507S0521849	
UNJC	NR 6	-	32	2,85	≈ DIN 371	56	12	20	4	3	6504B0103		6507S0521854	
UNJC	NR 8	-	32	3,5	≈ DIN 371	63	13	21	4,5	3,4	6504B0104		6507S0521857	
UNJC	NR 10	-	24	3,9	≈ DIN 371	70	15	25	6	4,9	6504B0105		6507S0521859	
UNJC	1/4	-	20	5,25	≈ DIN 371	80	17	30	7	5,5	6504B0106		6507S0521860	
UNJC	5/16	-	18	6,7	≈ DIN 371	90	20	35	8	6,2	6504B0107		6507S0087909	
UNJC	3/8	-	16	8,1	≈ DIN 371	100	22	39	10	8	6504B0108			
										3BX		3BX		
UNJF	NR 4	-	48	2,4	≈ DIN 371	56	11	18	3,5	2,7	6504B0109		6507S0521861	
UNJF	NR 6	-	40	3	≈ DIN 371	56	12	20	4	3	6504B0110		6507S0521862	
UNJF	NR 8	-	36	3,55	≈ DIN 371	63	13	21	4,5	3,4	6504B0111		6507S0521864	
UNJF	NR 10	-	32	4,15	≈ DIN 371	70	15	25	6	4,9	6504B0112		6507F0004	
UNJF	1/4	-	28	5,55	≈ DIN 371	80	17	30	7	5,5	6504B0113		6507S0254322	
UNJF	5/16	-	24	7	≈ DIN 371	90	17	35	8	6,2	6504B0114		6507F0003	
UNJF	3/8	-	24	8,6	≈ DIN 371	90	18	35	10	8	6504B0115			

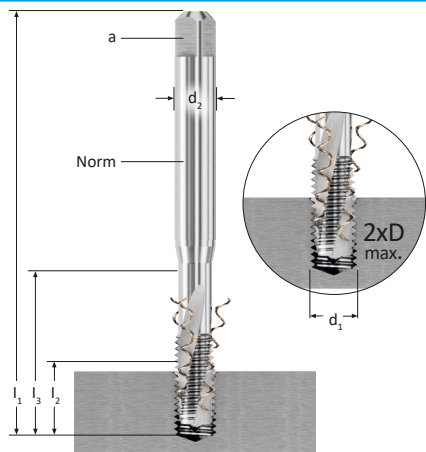

OBERFLÄCHE / SURFACE SURFACE / SUPERFICIE										TICN		TICN		
SCHNEIDSTOFF / MATERIAL MATIÈRE / MATERIALE										HSSE		HSSE-PM		
ANSCHNITTFORM / CHAMFER FORM FORME D'ENTRÉE / FORMA D'IMBOCCO										C / 2-3		C / 2-3		
d_1	x	P		NORM	l_1	l_2	l_3	d_2	a	ISO1X		ISO1X		
MJ	3	x	0,5	2,6	DIN 371	56	11	18	3,5	2,7	6604A1856		66A7B0381	
MJ	4	x	0,7	3,4	DIN 371	63	13	21	4,5	3,4	6604A1857		66A7B0382	
MJ	5	x	0,8	4,3	DIN 371	70	15	25	6	4,9	6604A1858		66A7B0383	
MJ	6	x	1	5,1	DIN 371	80	17	30	6	4,9	6604A1859		66A7B0384	
MJ	8	x	1	7,1	DIN 371	90	17	35	8	6,2	6604A1860		66A7B0385	
MJ	8	x	1,25	6,9	DIN 371	90	20	35	8	6,2	6604A1862		66A7B0387	
MJ	10	x	1,25	8,9	DIN 371	100	18	39	10	8	6604A1861		66A7B0386	
MJ	10	x	1,5	8,9	DIN 371	100	22	39	10	8	6604A1863		66A7B0386	
d_1	- P/1"				NORM	l_1	l_2	l_3	d_2	a	3BX		3BX	
UNJC	NR 4	-	40	2,3	≈ DIN 371	56	11	18	3,5	2,7	6604B0144		66A7S0522262	
UNJC	NR 6	-	32	2,85	≈ DIN 371	56	12	20	4	3	6604B0145		66A7S0522263	
UNJC	NR 8	-	32	3,5	≈ DIN 371	63	13	21	4,5	3,4	6604B0146		66A7S0522264	
UNJC	NR 10	-	24	3,9	≈ DIN 371	70	15	25	6	4,9	6604B0147		66A7S0522265	
UNJC	1/4	-	20	5,25	≈ DIN 371	80	17	30	7	5,5	6604B0148		66A7S0522266	
UNJC	5/16	-	18	6,7	≈ DIN 371	90	20	35	8	6,2	6604B0149		66A7S0522267	
UNJC	3/8	-	16	8,1	≈ DIN 371	100	22	39	10	8	6604B0150			
d_1	- P/1"				NORM	l_1	l_2	l_3	d_2	a	3BX		3BX	
UNJF	NR 4	-	48	2,4	≈ DIN 371	56	11	18	3,5	2,7	6604B0151		66A7S0522268	
UNJF	NR 6	-	40	3	≈ DIN 371	56	12	20	4	3	6604B0152		66A7S0522269	
UNJF	NR 8	-	36	3,55	≈ DIN 371	63	13	21	4,5	3,4	6604B0153		66A7S0522270	
UNJF	NR 10	-	32	4,15	≈ DIN 371	70	15	25	6	4,9	6604B0154		66A7S0522271	
UNJF	1/4	-	28	5,55	≈ DIN 371	80	17	30	7	5,5	6604B0155		66A7S0522272	
UNJF	5/16	-	24	7	≈ DIN 371	90	17	35	8	6,2	6604B0156		66A7S0522273	
UNJF	3/8	-	24	8,6	≈ DIN 371	90	18	35	10	8	6604B0157			

EG (STI)

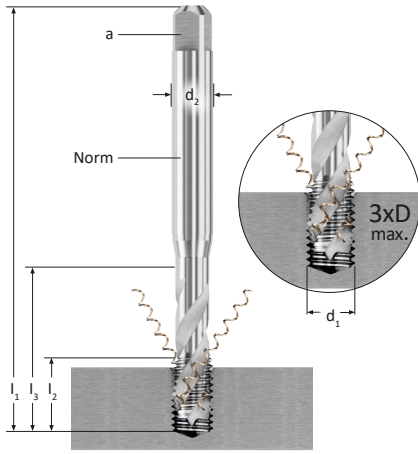

UNI



NORIS SALOREX
VA

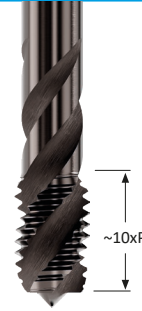

SOFT

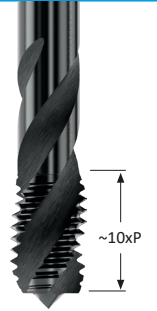

OBERFLÄCHE / SURFACE SURFACE / SUPERFICIE										VAP	ALTiNHd	DLC	
SCHNEIDSTOFF / MATERIAL MATIÈRE / MATERIALE										HSSE	HSSE	HSSE	
ANSCHNITTFORM / CHAMFER FORM FORME D'ENTRÉE / FORMA D'IMBOCCO										E / 1,5-2	E / 1,5-2	C / 2-3	
d ₁	x	P		NORM	l ₁	l ₂	l ₃	d ₂	a	6H mod	6H mod	6H mod	
EG-M	2,5	x	0,45	2,65	DIN 40435	56	11	18	3,5	2,7	6642AEKAC		664SB0172
EG-M	3	x	0,5	3,15	DIN 40435	63	10	21	4,5	3,4	6642AHQAA	6645B0243	664SB0173
EG-M	4	x	0,7	4,2	DIN 40435	70	12	25	6	4,9	6642AHYAB	6645B0245	664SB0174
EG-M	5	x	0,8	5,25	DIN 40435	80	13	30	6	4,9	6642AHZAC	6645B0246	664SB0175
EG-M	6	x	1	6,3	DIN 40435	90	17	35	8	6,2	6642AH0AB	6645B0247	664SB0176
EG-M	8	x	1,25	8,4	DIN 40435	100	18	39	10	8	6642A9AB	6645B0248	664SB0177
EG-M	10	x	1,5	10,5	DIN 40435	110	21	44	12	9	7642AMHAB	7645B0616	764SB0567
EG-M	12	x	1,75	12,5	DIN 40435	110	26	-	11	9	7642APIAB		764SB0568
EG-M	16	x	2	16,5	DIN 40435	125	27	-	14	11	7642AWZAA		
EG-M	20	x	2,5	20,75	DIN 40435	160	34	-	18	14,5	7642AW0AA		
d ₁	-	P/1"		NORM	l ₁	l ₂	l ₃	d ₂	a	2B			
EG-UNC	NR 4	-	40	3,1	≈ DIN 371	63	6	21	4,5	3,4	6642AMYAB		
EG-UNC	NR 6	-	32	3,8	≈ DIN 371	70	7	25	6	4,9	6642ANDAA		
EG-UNC	NR 8	-	32	4,4	≈ DIN 371	80	8	30	6	4,9	6642AJZAA		
EG-UNC	NR 10	-	24	5,2	≈ DIN 371	80	10	30	7	5,5	6642ANAAA		
EG-UNC	1/4	-	20	6,7	≈ DIN 371	90	13	35	8	6,2	6642ANFAA		
EG-UNC	5/16	-	18	8,4	≈ DIN 371	100	14	39	10	8	6642ANGAA		
EG-UNC	3/8	-	16	10	≈ DIN 376	100	16	-	9	7	7642A1964		
EG-UNC	7/16	-	14	11,6	≈ DIN 376	110	18	-	11	9	7642A1965		
EG-UNC	1/2	-	13	13,3	≈ DIN 376	110	20	-	12	9	7642A1966		
EG-UNC	9/16	-	12	14,9	≈ DIN 376	110	20	-	12	9	7642A1967		
EG-UNC	5/8	-	11	16,5	≈ DIN 376	125	22	-	14	11	7642A1968		
EG-UNC	3/4	-	10	19,75	≈ DIN 376	140	25	-	18	14,5	7642A1969		
d ₁	-	P/1"		NORM	l ₁	l ₂	l ₃	d ₂	a	2B			
EG-UNF	NR 4	-	48	3	≈ DIN 371	56	6	20	4	3	6642ANHAA		
EG-UNF	NR 6	-	40	3,7	≈ DIN 371	70	7	25	6	4,9	6642ANIAA		
EG-UNF	NR 8	-	36	4,4	≈ DIN 371	80	8	30	6	4,9	6642ANJAA		
EG-UNF	NR 10	-	32	5,1	≈ DIN 371	80	10	30	6	4,9	6642AEEAB		
EG-UNF	1/4	-	28	6,6	≈ DIN 371	90	13	35	8	6,2	6642AEFAB		
EG-UNF	5/16	-	24	8,25	≈ DIN 371	90	14	35	10	8	6642F0036		
EG-UNF	3/8	-	24	9,8	≈ DIN 376	90	16	-	8	6,2	7642A1972		
EG-UNF	7/16	-	20	11,5	≈ DIN 376	100	18	-	9	7	7642A1973		
EG-UNF	1/2	-	20	13,1	≈ DIN 376	100	20	-	11	9	7642A1974		
EG-UNF	9/16	-	18	14,9	≈ DIN 376	110	20	-	12	9	7642A1975		
EG-UNF	5/8	-	18	16,5	≈ DIN 376	125	22	-	14	11	7642A1976		
EG-UNF	3/4	-	16	19,75	≈ DIN 376	140	25	-	18	14,5	7642A1977		

EG (STI)

NORIS STABIL

UNI

VA

SOFT

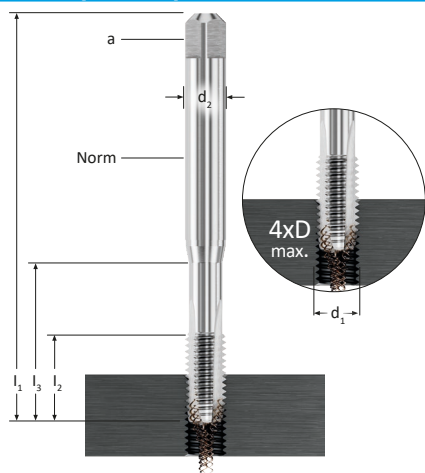

OBERFLÄCHE / SURFACE SURFACE / SUPERFICIE										NITVAP			ALTiNHd			DLC			
SCHNEIDSTOFF / MATERIAL MATIÈRE / MATERIALE										HSSE			HSSE			HSSE			
ANSCHNITTFORM / CHAMFER FORM FORME D'ENTRÉE / FORMA D'IMBOCCO										B / 4-5			B / 4-5			B / 4-5			
d_1	x	P		NORM	l_1	l_2	l_3	d_2	a	6H mod			6H mod			6H mod			
EG-M	2,5	x	0,45	2,65	DIN 40435	56	11	18	3,5	2,7	6560ADSAa						657SB0033		
EG-M	3	x	0,5	3,15	DIN 40435	63	10	21	4,5	3,4	6560ADTAa			6535S0521873			657SB0034		
EG-M	4	x	0,7	4,2	DIN 40435	70	12	25	6	4,9	6560ADUAA			6535S0521875			657SB0035		
EG-M	5	x	0,8	5,25	DIN 40435	80	13	30	6	4,9	6560ADVAA			6535S0521877			657SB0036		
EG-M	6	x	1	6,3	DIN 40435	90	17	35	8	6,2	6560ADWAA			6535S0521879			657SB0037		
EG-M	8	x	1	7,3	DIN 40435	90	17	35	8	6,2									
EG-M	8	x	1,25	8,4	DIN 40435	100	18	39	10	8	6560ADXAA			6535S0521880			657SB0038		
EG-M	10	x	1,5	10,5	DIN 40435	100	22	-	9	7	7560AHNAA								
EG-M	12	x	1,75	12,5	DIN 40435	110	26	-	11	9	7560AHPAA								
EG-M	16	x	2	16,5	DIN 40435	125	27	-	14	11	7560AHQAA								
EG-M	20	x	2,5	20,75	DIN 40435	160	34	-	18	14,5	7560AHRAA								
d_1	-	P/1"		NORM	l_1	l_2	l_3	d_2	a	2B									
EG-UNC	NR 4	-	40	3,1	≈ DIN 371	63	13	21	4,5	3,4	6560ADYAA								
EG-UNC	NR 6	-	32	3,8	≈ DIN 371	70	14	25	6	4,9	6560AD0AA								
EG-UNC	NR 8	-	32	4,4	≈ DIN 371	80	16	30	6	4,9	6560AD1AA								
EG-UNC	NR 10	-	24	5,2	≈ DIN 371	80	17	30	7	5,5	6560AD2AA								
EG-UNC	1/4	-	20	6,7	≈ DIN 371	90	20	35	8	6,2	6560AD3AA								
EG-UNC	5/16	-	18	8,4	≈ DIN 371	100	22	39	10	8	6560AD4AA								
EG-UNC	3/8	-	16	10	≈ DIN 376	100	22	-	9	7	7560AHTAA								
EG-UNC	7/16	-	14	11,6	≈ DIN 376	110	26	-	11	9	7560AHUAA								
EG-UNC	1/2	-	13	13,3	≈ DIN 376	110	27	-	12	9	7560AHVAA								
EG-UNC	9/16	-	12	14,9	≈ DIN 376	110	27	-	12	9	7560A1971								
EG-UNC	5/8	-	11	16,5	≈ DIN 376	125	30	-	14	11	7560AHWAA								
EG-UNC	3/4	-	10	19,75	≈ DIN 376	140	32	-	18	14,5	7560AHXAA								
d_1	-	P/1"		NORM	l_1	l_2	l_3	d_2	a	2B									
EG-UNF	NR 4	-	48	3	≈ DIN 371	56	9	20	4	3	6560AD5AA								
EG-UNF	NR 6	-	40	3,7	≈ DIN 371	70	11	25	6	4,9	6560AD6AA								
EG-UNF	NR 8	-	36	4,4	≈ DIN 371	80	13	30	6	4,9	6560AD7AA								
EG-UNF	NR 10	-	32	5,1	≈ DIN 371	80	13	30	6	4,9	6560AD8AA								
EG-UNF	1/4	-	28	6,6	≈ DIN 371	90	17	35	8	6,2	6560AD9AA								
EG-UNF	5/16	-	24	8,25	≈ DIN 371	90	18	35	10	8	6560A1978								
EG-UNF	3/8	-	24	9,8	≈ DIN 376	90	18	-	8	6,2	7560AHZAA								
EG-UNF	7/16	-	20	11,5	≈ DIN 376	100	22	-	9	7	7560AH0AA								
EG-UNF	1/2	-	20	13,1	≈ DIN 376	100	22	-	11	9	7560AH1AA								
EG-UNF	9/16	-	18	14,9	≈ DIN 376	110	27	-	12	9	7560A1981								
EG-UNF	5/8	-	18	16,5	≈ DIN 376	125	30	-	14	11	7560AH2AA								
EG-UNF	3/4	-	16	19,75	≈ DIN 376	140	32	-	18	14,5	7560AH3AA								

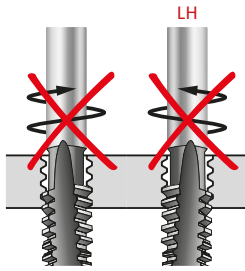
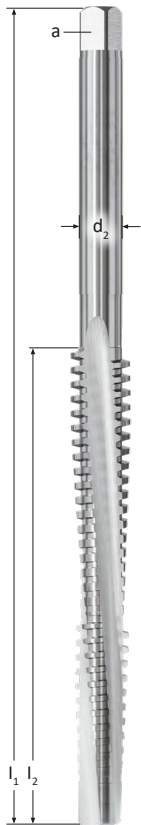

Nicht reversieren!
No reversal!
Ne pas renverser la marche!
Non invertire la marcia!



2xD
max



2xD
max

OBERFLÄCHE / SURFACE SURFACE / SUPERFICIE								-	-
SCHNEIDSTOFF / MATERIAL MATIÈRE / MATERIALE								HSSE	HSSE
ANSCHNITTFORM / CHAMFER FORM FORME D'ENTRÉE / FORMA D'IMBOCCO								-	-
d_1	x	P		l_1	l_2	d_2	a	7H	7H - LH
TR 8	x	1,5	6,6	105	55	6	4,9	9720AAAAA	9720AABAA
TR 9	x	2	7,2	130	70	7	5,5	9720AAEAA	9720AAFAA
TR 10	x	2	8,2	130	70	7	5,5	9720AAIAA	9720AAKAA
TR 10	x	3	7,25	155	95	7	5,5	9720AAMAA	9720AANAA
TR 11	x	3	8,25	155	95	8	6,2	9720AARAA	9720AASAA
TR 12	x	3	9,25	160	95	9	7	9720AAWAA	9720AAXAA
TR 14	x	3	11,25	170	100	10	8	9720AA2AA	9720AA3AA
TR 14	x	4	10,25	195	125	10	8	9720AA4AA	9720AA5AA
TR 16	x	4	12,25	225	130	12	9	9720AA9AA	9720ABAAA
TR 18	x	4	14,25	225	130	14	11	9720ABFAA	9720ABGAA
TR 20	x	4	16,25	225	130	16	12	9720ABKAA	9720ABLAA
TR 22	x	5	17,25	260	160	16	12	9720ABRAA	9720ABSAA
TR 24	x	5	19,25	285	165	18	14,5	9720ABWAA	9720ABXAA
TR 26	x	5	21,25	285	165	20	16	9720AB2AA	9720AB4AA
TR 28	x	5	23,25	300	170	22	18	9720AB9AA	9720ACAAA
TR 30	x	6	24,25	335	200	22	18	9720ACDAA	9720ACEAA
TR 32	x	6	26,25	335	200	25	20	9720ACGAA	9720ACIAA
TR 34	x	6	28,25	350	205	28	22	9720ACKAA	9720ACMAA

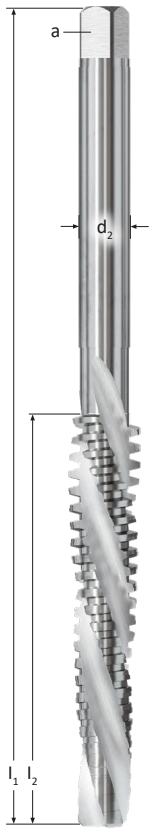

Muss mit zwangsläufiger Steigung geschnitten werden!
Positive feed control is necessary!
L'usinage doit être réalisé avec une avance forcée!
Si deve tagliare con passo controllato!



1,5xD
max



1,5xD
max

OBERFLÄCHE / SURFACE SURFACE / SUPERFICIE							NIT	NIT
SCHNEIDSTOFF / MATERIAL MATIÈRE / MATERIALE							HSSE	HSSE
ANSCHNITTFORM / CHAMFER FORM FORME D'ENTRÉE / FORMA D'IMBOCCO							-	-
d_1	x	P		l_1	d_2	a	7H	7H - LH
TR 8	x	1,5	6,6	90	6	4,9	9745F0002	9745F0017
TR 9	x	2	7,2	110	7	5,5	9745F0003	9745F0018
TR 10	x	2	8,2	110	7	5,5	9745F0004	9745F0019
TR 10	x	3	7,25	130	7	5,5	9745F0005	9745F0020
TR 11	x	3	8,25	130	8	6,2	9745F0006	9745F0021
TR 12	x	3	9,25	140	9	7	9745F0001	9745F0022
TR 14	x	3	11,25	145	10	8	9745F0007	9745F0023
TR 14	x	4	10,25	165	10	8	9745F0008	9745F0024
TR 16	x	4	12,25	190	12	9	9745F0009	9745F0025
TR 18	x	4	14,25	195	14	11	9745F0010	9745F0026
TR 20	x	4	16,25	195	16	12	9745F0011	9745F0027
TR 22	x	5	17,25	220	16	12	9745F0012	9745F0028
TR 24	x	5	19,25	245	18	14,5	9745F0013	9745F0029

TR DIN 103

NORIS TWIN MS AUT

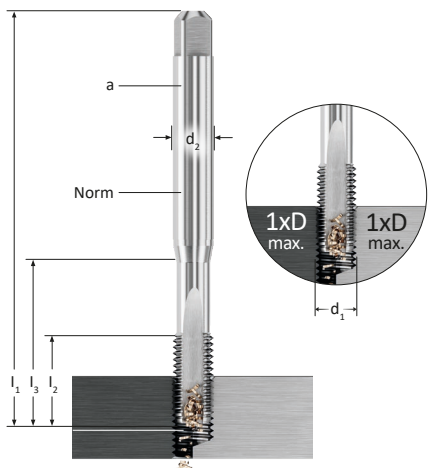

AUT

OBERFLÄCHE / SURFACE SURFACE / SUPERFICIE	-
SCHNEIDSTOFF / MATERIAL MATIÈRE / MATERIALE	HSSE
ANSCHNITTFORM / CHAMFER FORM FORME D'ENTRÉE / FORMA D'IMBOCCO	E / 1,5-2

d ₁	x	P	NORM	l ₁	l ₂	l ₃	d ₂	a	7H	
TR 8	x	1,5	6,6	≈ DIN 352	70	22	-	8	6,2	5250F0141
TR 8	x	2	6,2	≈ DIN 352	70	22	-	8	6,2	5250F0142
TR 9	x	1,5	7,6	≈ DIN 352	70	22	-	8	6,2	5250F0149
TR 9	x	2	7,2	≈ DIN 352	70	22	-	8	6,2	5250F0143
TR 10	x	1,5	8,6	≈ DIN 352	70	22	-	8	6,2	5250F0150
TR 10	x	2	8,2	≈ DIN 352	70	22	-	8	6,2	5250F0144
TR 10	x	3	7,25	≈ DIN 352	70	22	-	8	6,2	5250F0070
TR 11	x	2	9,2	≈ DIN 352	75	24	-	9	7	5250F0151
TR 11	x	3	8,25	≈ DIN 352	75	24	-	9	7	5250F0145
TR 12	x	2	10,2	≈ DIN 352	75	25	-	9	7	5250F0085
TR 12	x	3	9,25	≈ DIN 352	75	25	-	9	7	5250F0020
TR 14	x	2	12,2	≈ DIN 352	80	26	-	10	8	5250F0152
TR 14	x	3	11,25	≈ DIN 352	80	26	-	10	8	5250F0146
TR 14	x	4	10,25	≈ DIN 352	80	26	-	10	8	5250F0021
TR 16	x	2	14,2	≈ DIN 352	80	27	-	12	9	5250F0153
TR 16	x	4	12,25	≈ DIN 352	80	27	-	12	9	5250F0147
TR 18	x	2	16,2	≈ DIN 352	80	22	-	12	9	5250F0154
TR 18	x	4	14,25	≈ DIN 352	95	32	-	12	9	5250F0015
TR 20	x	2	18,2	≈ DIN 352	80	22	-	15	12	5250F0155
TR 20	x	4	16,25	≈ DIN 352	95	32	-	15	12	5250F0148
TR 22	x	3	19,25	≈ DIN 352	100	32	-	15	12	5250F0156
TR 24	x	3	21,25	≈ DIN 352	110	36	-	18	14,5	5250F0157
TR 26	x	3	23,25	≈ DIN 352	110	36	-	18	14,5	5250F0158
TR 28	x	3	25,25	≈ DIN 352	125	36	-	18	14,5	5250F0159
TR 30	x	3	27,25	≈ DIN 352	125	34	-	18	14,5	5250F0160

TR DIN 103

NORIS DL15 ST

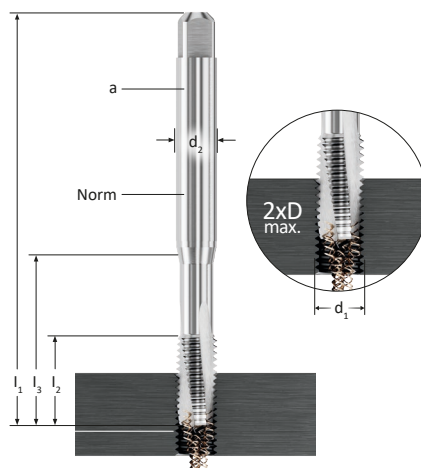

OBERFLÄCHE / SURFACE SURFACE / SUPERFICIE	-
SCHNEIDSTOFF / MATERIAL MATIÈRE / MATERIALE	HSSE
ANSCHNITTFORM / CHAMFER FORM FORME D'ENTRÉE / FORMA D'IMBOCCO	D / 4-5

d ₁	x	P	NORM	l ₁	l ₂	l ₃	d ₂	a	7H	7H - LH	
TR 9	x	1,5	7,6	≈ DIN 374	100	22	-	7	5,5	7500F0003	7500F0014
TR 10	x	1,5	8,6	≈ DIN 374	100	22	-	7	5,5	7500F0004	7500F0015
TR 11	x	2	9,2	≈ DIN 374	100	22	-	8	6,2	7500F0005	7500F0016
TR 12	x	2	10,2	≈ DIN 374	110	25	-	9	7	7500F0002	7500F0017
TR 14	x	2	12,2	≈ DIN 374	110	26	-	11	9	7500F0006	7500F0018
TR 16	x	2	14,2	≈ DIN 374	110	27	-	12	9	7500F0007	7500F0019
TR 18	x	2	16,2	≈ DIN 374	125	27	-	14	11	7500F0008	7500F0020
TR 20	x	2	18,2	≈ DIN 374	140	27	-	16	12	7500F0001	7500F0021
TR 22	x	3	19,25	≈ DIN 374	160	34	-	18	14,5	7500F0009	7500F0022
TR 24	x	3	21,25	≈ DIN 374	160	36	-	18	14,5	7500F0010	7500F0023
TR 26	x	3	23,25	≈ DIN 374	160	36	-	20	16	7500F0011	7500F0024
TR 28	x	3	25,25	≈ DIN 374	180	40	-	22	18	7500F0012	7500F0025
TR 30	x	3	27,25	≈ DIN 374	180	40	-	22	18	7500F0013	7500F0026

RD DIN 405

NORIS
TWIN ST

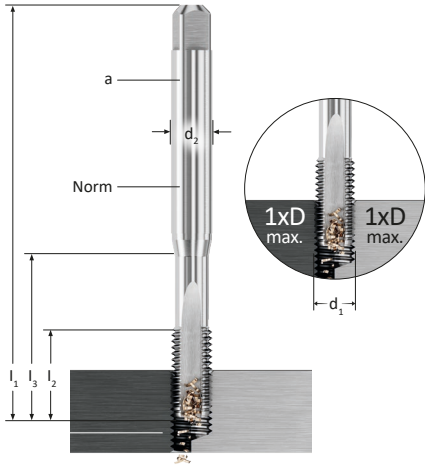

OBERFLÄCHE / SURFACE SURFACE / SUPERFICIE	-
SCHNEIDSTOFF / MATERIAL MATIÈRE / MATERIALE	HSSE
ANSCHNITTFORM / CHAMFER FORM FORME D'ENTRÉE / FORMA D'IMBOCCO	C / 2-3

d ₁	x P/1"		NORM	l ₁	l ₂	l ₃	d ₂	a	7H
RD 8	x 10	6	≈ DIN 352	70	22	-	8	6,2	7100F0031
RD 9	x 10	7	≈ DIN 352	70	22	-	8	6,2	7100F0032
RD 10	x 10	8	≈ DIN 352	70	22	-	8	6,2	7100F0033
RD 11	x 10	9	≈ DIN 352	70	22	-	8	6,2	7100AGTAA
RD 12	x 10	10	≈ DIN 352	75	25	-	9	7	7100AGUAA
RD 14	x 8	11,5	≈ DIN 352	80	26	-	11	9	7100AGVAA
RD 16	x 8	13,5	≈ DIN 352	80	27	-	12	9	7100AGWAA
RD 18	x 8	15,5	≈ DIN 352	95	32	-	14	11	7100AGXAA
RD 20	x 8	17,5	≈ DIN 352	95	32	-	16	12	7100AGYAA
RD 22	x 8	19,5	≈ DIN 352	100	32	-	18	14,5	7100AGZAA
RD 24	x 8	21,5	≈ DIN 352	110	36	-	18	14,5	7100AGOAA
RD 26	x 8	23,5	≈ DIN 352	110	36	-	20	16	7100AG1AA
RD 28	x 8	25,5	≈ DIN 352	125	34	-	22	18	7100AG2AA
RD 30	x 8	27,5	≈ DIN 352	125	34	-	22	18	7100AG3AA

PG DIN 40430

NORIS
TWIN ST

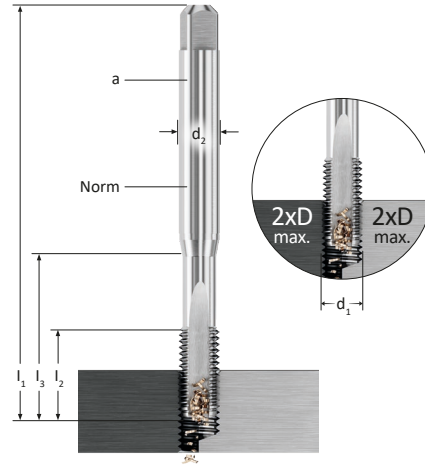

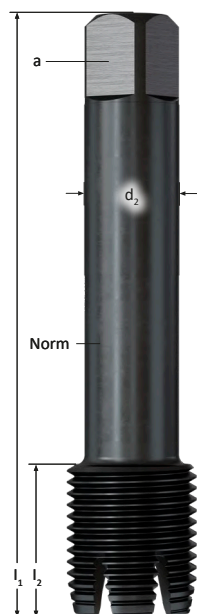

OBERFLÄCHE / SURFACE SURFACE / SUPERFICIE	-
SCHNEIDSTOFF / MATERIAL MATIÈRE / MATERIALE	HSSE
ANSCHNITTFORM / CHAMFER FORM FORME D'ENTRÉE / FORMA D'IMBOCCO	C / 2-3

d ₁	x P/1"		NORM	l ₁	l ₂	l ₃	d ₂	a	X
PG 7	x 20	11,35	DIN 40433	100	22	-	9	7	7100B0427
PG 9	x 18	13,95	DIN 40433	100	22	-	12	9	7100B0428
PG 11	x 18	17,35	DIN 40433	110	25	-	14	11	7100B0429
PG 13,5	x 18	19,15	DIN 40433	125	25	-	16	12	7100B0430
PG 16	x 18	21,25	DIN 40433	125	25	-	18	14,5	7100B0431
PG 21	x 16	26,95	DIN 40433	150	28	-	22	18	7100B0432
PG 29	x 16	35,6	DIN 40433	170	30	-	28	22	7100B0433
PG 36	x 16	45,6	DIN 40433	190	32	-	36	29	7100B0434
PG 42	x 16	52,6	DIN 40433	190	32	-	40	32	7100B0435
PG 48	x 16	57,9	DIN 40433	220	36	-	45	35	7100B0436

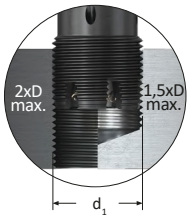
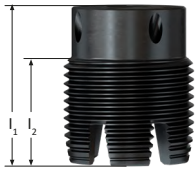

OBERFLÄCHE / SURFACE SURFACE / SUPERFICIE											VAP
SCHNEIDSTOFF / MATERIAL MATIÈRE / MATERIALE											HSSE
ANSCHNITTFORM / CHAMFER FORM FORME D'ENTRÉE / FORMA D'IMBOCCO											C / 2-3
d_1	P		NORM	l_1	l_2	l_3	d_2	a			ISO2X
M 30	3,5	26,5	DIN 376	180	45	-	22	18			7682ABQAA
M 33	3,5	29,5	DIN 376	180	45	-	25	20			7682ABRAA
M 36	4	32	DIN 376	200	52	-	28	22			7682AAJAB
M 42	4,5	37,5	DIN 376	200	59	-	32	24			7682AAHAB
M 45	4,5	40,5	DIN 376	220	59	-	36	29			7682AAAAB
M 48	5	43	DIN 376	250	65	-	36	29			7682AAGAB
M 52	5	47	DIN 376	250	65	-	40	32			7682AAFAB
M 56	5,5	50,5	DIN 376	280	72	-	45	35			7682AAMAA
M 60	5,5	54,5	DIN 376	280	72	-	45	35			7682AAPAA
M 64	6	58	DIN 376	315	78	-	50	39			7682AAQAA
											ISO2X
MF 30	x 2	28	≈ DIN 374	150	28	-	22	18			7682ABAAA
MF 33	x 2	31	≈ DIN 374	160	30	-	25	20			7682AB3AA
MF 36	x 3	33	≈ DIN 374	200	45	-	28	22			7682AB5AA
MF 39	x 3	36	≈ DIN 374	200	45	-	32	24			7682AB8AA
MF 42	x 3	39	≈ DIN 374	200	50	-	32	24			7682ACDAA
MF 45	x 3	42	≈ DIN 374	200	50	-	36	29			7682ACFAA
MF 48	x 3	45	≈ DIN 374	225	50	-	36	29			7682ACIAA
MF 72	x 6	66	≈ DIN 374	340	78	-	56	44			7682AAZAB
											2BX
UNC 3/4	- 10	16,5	≈ DIN 376	125	32	-	14	11			7682ACXAC
UNC 1	- 8	22,25	≈ DIN 376	160	36	-	20	16			7682AC8AA



OBERFLÄCHE / SURFACE SURFACE / SUPERFICIE						VAP					
SCHNEIDSTOFF / MATERIAL MATIÈRE / MATERIALE						HSSE					
ANSCHNITTFORM / CHAMFER FORM FORME D'ENTRÉE / FORMA D'IMBOCCO						C / 2-3					
d_1	x P		l_1	l_2	ISO2X	d_1	l_1	d_2	a		
M 64	x 6	58	92	68	7692ADNAC	III L	> 63 - 74 mm	225	32	24	9940AAKAA
ISO2X											
MF 52	x 3	49	54	36	7692AAGAB	I L	> 45 - 54 mm	169	25	20	9940AAIAA
MF 56	x 4	52	73	50	7692AALAA	II L	> 54 - 63 mm	183	28	22	9940AAJAA
MF 64	x 3	61	67	40	7692AAPAA						
MF 64	x 4	60	81	56	7692AAQAB						
MF 68	x 4	64	81	56	7692AAVAB	III L	> 63 - 74 mm	225	32	24	9940AAKAA
MF 72	x 3	69	67	40	7692AAZAA						
MF 72	x 4	68	81	56	7692AA0AB						
MF 72	x 6	66	94	70	7692AA1AA						
MF 76	x 3	73	74	45	7692AA4AA						
MF 76	x 6	70	97	70	7692AA6AA	IV L	> 74 - 84 mm	247	40	32	9940AALAA
MF 80	x 4	76	86	56	7692AA8AA						
MF 80	x 6	74	97	70	7692AA9AC						
MF 85	x 4	81	86	56	7692ABBAA						
MF 85	x 6	79	97	70	7692ABCAA						
MF 90	x 4	86	86	56	7692ABEAA	V L	> 84 - 99 mm	279	45	35	9940AAMAA
MF 90	x 6	84	97	70	7692ABFAB						
MF 95	x 6	89	107	70	7692AEUAE						
MF 100	x 6	94	107	70	7692ABKAA	VI L	> 99 - 120 mm	317	50	39	9940AANAA

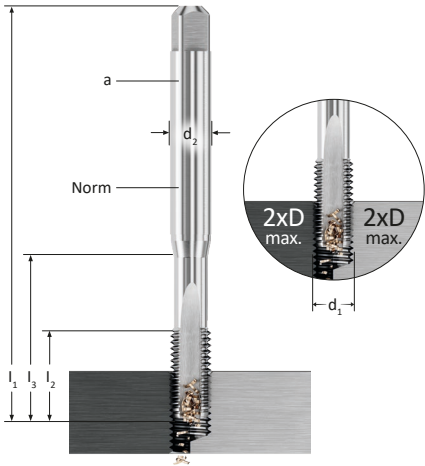

V1

M2

F3

SET

OBERFLÄCHE / SURFACE SURFACE / SUPERFICIE										-				
SCHNEIDSTOFF / MATERIAL MATIÈRE / MATERIALE										HSSE				
ANSCHNITTFORM / CHAMFER FORM FORME D'ENTRÉE / FORMA D'IMBOCCO										A / 5-6	D / 3-4	C / 2-3		
d ₁	P		NORM	l ₁	l ₂	l ₃	d ₂	a			ISO 1X		ISO 1X	
M 1	0,25	0,75	DIN 352	32	5	-	2,5	2,1	5000AHMAA	5000AHNAA	5000AHPAA		5000AHLAA	
M 1,4	0,3	1,1	DIN 352	32	7	-	2,5	2,1	5000AAFAA	5000AAGAA	5000AAHAA		5000AAEAA	
M 1,6	0,35	1,25	DIN 352	32	8	-	2,5	2,1	5000ANAA	5000AAPAA	5000AAQAA		5000AAMAA	
M 2	0,4	1,6	DIN 352	36	8	-	2,8	2,1	5000ABCAA	5000ABDAA	5000ABEAA		5000ABBAA	
M 2,5	0,45	2,05	DIN 352	40	9	-	2,8	2,1	5000AB1AA	5000AB2AA	5000AB3AA		5000AB0AA	
M 3	0,5	2,5	DIN 352	40	10	18	3,5	2,7	5000ACHAA	5000ACIAA	5000ACJAA		5000ACGAA	
M 3,5	0,6	2,9	DIN 352	45	11	20	4	3	5000ACQAA	5000ACRAA	5000ACSA		5000ACPA	
M 4	0,7	3,3	DIN 352	45	12	22	4,5	3,4	5000ACYAA	5000ACZAA	5000AC0AA		5000ACXAA	
M 5	0,8	4,2	DIN 352	50	14	25	6	4,9	5000AAJAA	5000AAKAA	5000AALAA		5000AAIAA	
M 6	1	5	DIN 352	56	16	28	6	4,9	5000AASAA	5000AATAA	5000AAUAA		5000AARAA	
M 7	1	6	DIN 352	56	18	-	6	4,9	5000AA0AA	5000AA1AA	5000AA2AA		5000AAZAA	
M 8	1,25	6,8	DIN 352	63	20	-	6	4,9	5000AA8AA	5000AA9AA	5000ABAAA		5000AA7AA	
M 10	1,5	8,5	DIN 352	70	22	-	7	5,5	5000ABPAA	5000ABQAA	5000ABRAA		5000ABNAA	
M 11	1,5	9,5	DIN 352	70	22	-	8	6,2	5000ABXAA	5000ABYAA	5000ABZAA		5000ABWAA	
M 12	1,75	10,2	DIN 352	75	24	-	9	7	5000AB5AA	5000AB6AA	5000AB7AA		5000AB4AA	
M 14	2	12	DIN 352	80	26	-	11	9	5000ACDAA	5000ACEAA	5000ACFAA		5000ACCAA	
M 16	2	14	DIN 352	80	27	-	12	9	5000ACLAA	5000ACMAA	5000ACNAA		5000ACKAA	
M 20	2,5	17,5	DIN 352	95	32	-	16	12	5000AC2AA	5000AC3AA	5000AC4AA		5000AC1AA	
M 24	3	21	DIN 352	110	34	-	18	14,5	5000ADIAA	5000ADJAA	5000ADKAA		5000ADHAA	
M 27	3	24	DIN 352	110	36	-	20	16	5000ADRAA	5000ADSAA	5000ADTAA		5000ADQAA	
M 30	3,5	26,5	DIN 352	125	40	-	22	18	5000ADZAA	5000AD0AA	5000AD1AA		5000ADYAA	
M 33	3,5	29,5	DIN 352	125	40	-	25	20	5000AD7AA	5000AD8AA	5000AD9AA		5000AD6AA	
M 36	4	32	DIN 352	150	50	-	28	22	5000AEFAA	5000AEGAA	5000AEHAA		5000AEEAA	
MF 4	0,35	3,65	DIN 2181	45	9	22	4,5	3,4	5000AJ6AA		5000AJ7AA		5000AJ5AA	
MF 4	0,5	3,5	DIN 2181	45	9	22	4,5	3,4	5000AJ9AA		5000AKAAA		5000AJ8AA	
MF 5	0,5	4,5	DIN 2181	50	11	25	6	4,9	5000AKPAA		5000AKQAA		5000AKNAA	
MF 6	0,5	5,5	DIN 2181	56	12	27	6	4,9	5000AKVAA		5000AKWAA		5000AKUAA	
MF 6	0,75	5,2	DIN 2181	56	12	27	6	4,9	5000AK1AA		5000AK2AA		5000AK0AA	
MF 8	0,5	7,5	DIN 2181	56	14	-	6	4,9	5000ALAAA		5000ALBAA		5000AL9AA	
MF 8	0,75	7,2	DIN 2181	56	14	-	6	4,9	5000ALDAA		5000ALEAA		5000ALCAA	
MF 8	1	7	DIN 2181	63	17	-	6	4,9	5000ALJAA		5000ALKAA		5000ALIAA	
MF 10	0,75	9,2	DIN 2181	63	18	-	7	5,5	5000ALZAA		5000AL0AA		5000ALYAA	
MF 10	1	9	DIN 2181	63	18	-	7	5,5	5000AL2AA		5000AL3AA		5000AL1AA	
MF 10	1,25	8,8	DIN 2181	70	22	-	7	5,5	5000AL8AA		5000AL9AA		5000AL7AA	
MF 12	1	11	DIN 2181	70	18	-	9	7	5000AMHAA		5000AMIAA		5000AMGAA	
MF 12	1,25	10,8	DIN 2181	70	20	-	9	7	5000AMNAA		5000AMPAA		5000AMMAA	
MF 12	1,5	10,5	DIN 2181	70	20	-	9	7	5000AMRAA		5000AMSAA		5000AMQAA	
MF 14	1	13	DIN 2181	70	18	-	11	9	5000AM0AA		5000AM1AA		5000AMZAA	
MF 14	1,25	12,8	DIN 2181	70	20	-	11	9	5000AM6AA		5000AM7AA		5000AM5AA	
MF 14	1,5	12,5	DIN 2181	70	20	-	11	9	5000AM9AA		5000ANAAA		5000AM8AA	
MF 16	1	15	DIN 2181	70	18	-	12	9	5000ANLAA		5000ANMAA		5000ANKAA	
MF 16	1,5	14,5	DIN 2181	70	20	-	12	9	5000ANPAA		5000ANQAA		5000ANNAA	
MF 18	1	17	DIN 2181	80	18	-	14	11	5000ANVAA		5000ANWAA		5000ANUAA	
MF 18	1,5	16,5	DIN 2181	80	22	-	14	11	5000ANYAA		5000ANZAA		5000ANXAA	
MF 18	2	16	DIN 2181	80	22	-	14	11	5000AN4AA		5000AN5AA		5000AN3AA	
MF 20	1	19	DIN 2181	80	18	-	16	12	5000AN7AA		5000AN8AA		5000AN6AA	
MF 20	1,5	18,5	DIN 2181	80	22	-	16	12	5000APAAA		5000APBAA		5000AN9AA	
MF 20	2	18	DIN 2181	80	22	-	16	12	5000APGAA		5000APHAA		5000APFAA	
MF 22	1	21	DIN 2181	80	18	-	18	14,5	5000APJAA		5000APKAA		5000APIAA	
MF 22	1,5	20,5	DIN 2181	80	22	-	18	14,5	5000APMAA		5000APNAA		5000APLAA	
MF 22	2	20	DIN 2181	80	22	-	18	14,5	5000APTAA		5000APUAA		5000APSA	
MF 24	1	23	DIN 2181	90	18	-	18	14,5	5000APWAA		5000APXAA		5000APVAA	



Vz1

M2

F3

SET

Vz1

M2

F3

SET

				NIT				
HSSE				HSSE				
C / 2-3				C / 2-3				

								d ₁	P
								M 1	0,25
								M 2	0,4
								M 2,5	0,45
								M 3	0,5
								M 3,5	0,6
								M 4	0,7
								M 5	0,8
								M 6	1
								M 7	1
								M 8	1,25
								M 10	1,5
								M 11	1,5
								M 12	1,75
								M 14	2
								M 16	2
								M 20	2,5
								M 24	3
								M 27	3
								M 30	3,5
								M 33	3,5
								M 36	4
								MF 4	0,35
								MF 4	0,5
								MF 5	0,5
								MF 6	0,5
								MF 6	0,75
								MF 8	0,5
								MF 8	0,75
								MF 10	0,75
								MF 10	1
								MF 10	1,25
								MF 12	1
								MF 12	1,25
								MF 12	1,5
								MF 14	1
								MF 14	1,25
								MF 14	1,5
								MF 16	1
								MF 16	1,5
								MF 18	1
								MF 18	1,5
								MF 18	2
								MF 20	1
								MF 20	1,5
								MF 20	2
								MF 22	1
								MF 22	1,5
								MF 22	2
								MF 24	1

Der Führungszapfen des Vz1 gewährleistet ein fluchtendes Anschneiden.

The guide journal of Vz1 ensures a flush lead.

La partie pilote de l'ébaucher assure un parfait centrage.

Il primo maschio della serie è munito di guida che assicura la centricità della filettatura con il preforo.

UNC | UNF ASME B1.1

NORIS SATZ ST

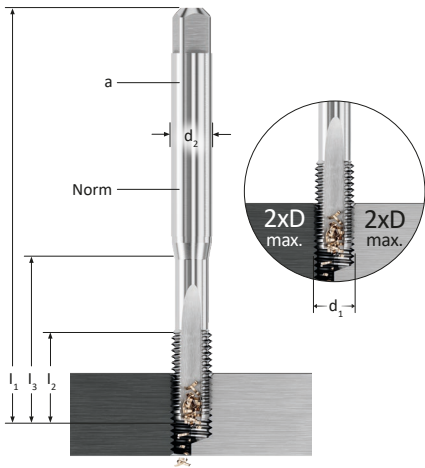

V1



M2



F3



SET

OBERFLÄCHE / SURFACE SURFACE / SUPERFICIE										-			
SCHNEIDSTOFF / MATERIAL MATIÈRE / MATERIALE										HSSE			
ANSCHNITTFORM / CHAMFER FORM FORME D'ENTRÉE / FORMA D'IMBOCCO										A / 5-6	D / 3-4	C / 2-3	
d ₁	-	P		NORM	l ₁	l ₂	l ₃	d ₂	a		2BX		2BX
UNC NR 4	-	40	2,35	DIN 352	40	10	18	3,5	2,7	5000ATHAA	5000A1259	5000BAZAA	5000A1234
UNC NR 6	-	32	2,85	DIN 352	45	11	20	4	3	5000ATNAA	5000A1261	5000BA5AA	5000A1236
UNC NR 8	-	32	3,5	DIN 352	45	12	22	4,5	3,4	5000ATRAA	5000A1262	5000BA8AA	5000A1237
UNC NR 10	-	24	3,9	DIN 352	50	14	25	6	4,9	5000ATXAA	5000A1263	5000BBEAA	5000A1238
UNC 1/4	-	20	5,1	DIN 352	56	16	28	6	4,9	5000ARYAA	5000A1265	5000A9FAA	5000A1240
UNC 5/16	-	18	6,6	DIN 352	63	20	-	6	4,9				
UNC 3/8	-	16	8	DIN 352	70	22	-	7	5,5	5000AR4AA	5000A1267	5000A9LAA	5000A1242
UNC 1/2	-	13	10,8	DIN 352	75	25	-	9	7	5000ASAAA	5000A1269	5000A9SAA	5000A1244
UNF 1/4	-	28	5,5	DIN 352	56	16	28	6	4,9				
UNF 5/16	-	24	6,9	DIN 352	63	17	-	6	4,9				
UNF 3/8	-	24	8,5	DIN 352	63	18	-	7	5,5				
UNF 7/16	-	20	9,9	DIN 352	70	22	-	8	6,2				
UNF 1/2	-	20	11,5	DIN 352	70	20	-	9	7				

G DIN-EN-ISO 228

NORIS SATZ ST

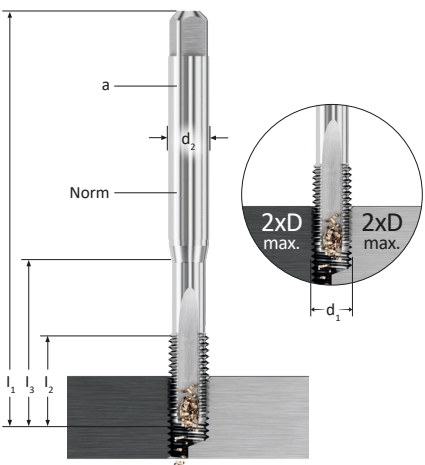

V1



F3



SET

OBERFLÄCHE / SURFACE SURFACE / SUPERFICIE										-			
SCHNEIDSTOFF / MATERIAL MATIÈRE / MATERIALE										HSSE			
ANSCHNITTFORM / CHAMFER FORM FORME D'ENTRÉE / FORMA D'IMBOCCO										D / 3-4	C / 2-3		
d ₁	-	P		NORM	l ₁	l ₂	l ₃	d ₂	a		2BX		2BX
G 1/8	-	28	8,8	DIN 352	63	18	-	7	5,5	5000AYWAA	5000AYXAA		5000AYVAA
G 1/4	-	19	11,8	DIN 352	70	20	-	11	9	5000AYZAA	5000AY0AA		5000AYYAA
G 3/8	-	19	15,25	DIN 352	70	20	-	12	9	5000AY2AA	5000AY3AA		5000AY1AA
G 1/2	-	14	19	DIN 352	80	22	-	16	12	5000AY5AA	5000AY6AA		5000AY4AA
G 3/4	-	14	24,5	DIN 352	90	22	-	20	16	5000AZBAA	5000AZCAA		5000AZAAA

NORIS SATZ ERGO



Vz1



M2



F3



SET

				d ₁	- P
-					
HSSE					
C / 2-3					
		2BX	2BX		
				UNC NR 4	- 40
				UNC NR 6	- 32
				UNC NR 8	- 32
				UNC NR 10	- 24
5020AQYAA	5020AQZAA	5020AQ0AA	5020AQXAA	UNC 1/4	- 20
5020AQ2AA	5020AQ3AA	5020AQ4AA	5020AQ1AA	UNC 5/16	- 18
5020AQ6AA	5020AQ7AA	5020AQ8AA	5020AQ5AA	UNC 3/8	- 16
5020AREAA	5020ARFAA	5020ARGAA	5020ARDAA	UNC 1/2	- 13
5020AN0AA	5020AN1AA	5020AN2AA	5020ANZAA	UNF 1/4	- 28
5020AN4AA	5020AN5AA	5020AN6AA	5020AN3AA	UNF 5/16	- 24
5020AN8AA	5020AN9AA	5020APAAA	5020AN7AA	UNF 3/8	- 24
5020APCAA	5020APDAA	5020APEAA	5020APBAA	UNF 7/16	- 20
5020APGAA	5020APHAA	5020APIAA	5020APFAA	UNF 1/2	- 20

NORIS SATZ ERGO



Vz1



M2



F3



SET

				d ₁	- P
-					
HSSE					
C / 2-3					
		2BX	2BX		
5020AJ9AA	5020AKAAA	5020AKBAA	5020AJ8AA	G 1/8	- 28
5020AKDAA	5020AKEAA	5020AKFAA	5020AKCAA	G 1/4	- 19
5020AKHAA	5020AKIAA	5020AKJAA	5020AKGAA	G 3/8	- 19
5020AKLAA	5020AKMAA	5020AKNAA	5020AKKAA	G 1/2	- 14
5020AKUAA	5020AKVAA	5020AKWAA	5020AKTAA	G 3/4	- 14

Der Führungszapfen des Vz1 gewährleistet ein fluchtendes Anschneiden.

The guide journal of Vz1 ensures a flush lead.

La partie pilote de l'ébaucher assure un parfait centrage.

Il primo maschio della serie è munito di guida che assicura la centricità della filettatura con il preforo.

Schaftverlängerungen, kurze Ausführung

Shank extensions, short design | Allonges porte-tarauts, version courte | Prolunghe speciali, esecuzione corta

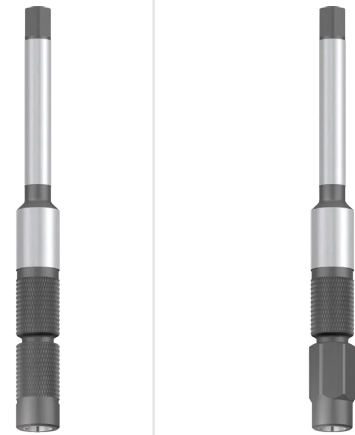
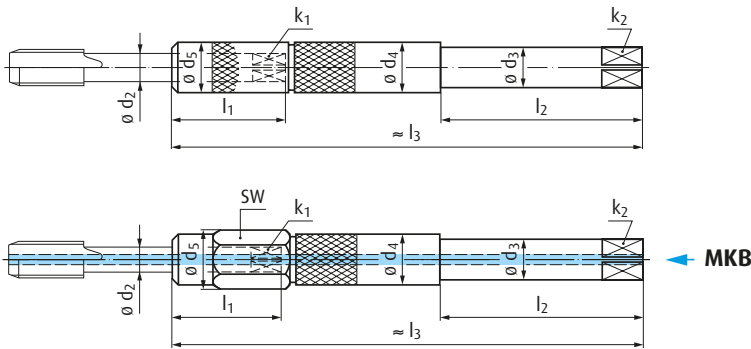

Für den Einsatz auf herkömmlichen Gewindeschneideinrichtungen
 For use on CNC machines and conventional thread cutting machinery
 Pour utilisation sur machines CNC et tous dispositifs de taraudage conventionnels
 Per l'impiego su macchina CNC ed apparecchiature a filettare tradizionali

Größe Size Taille Grand.	Baumaße Gewindebohrer Dimensions of tap Dimensions taraud Dimensioni maschio				Baumaße Schaftverlängerung Dimensions of extensions Dimensions allonge porte-taraud Dimensioni prolunga							MKB			
	d ₂	k ₁	DIN 371	DIN 374/376	l ₁	l ₂	l ₃	d ₃	k ₂	d ₄ /d ₅		d ₄	d ₅	SW	
1	2,8	2,1	M 2 - M2,6	M4	21	60	130	6	4,9	6,1	9951V01	6,1	6,5	6	9953VK01
2	3,5	2,7	M 3	M 4,5 - M 5	22	60	130	6	4,9	7,5	9951V02	7,5	9	8	9953VK02
3	4	3	M 3,5	M 5,5	22	60	130	6	4,9	8,4	9951V03	8,4	10	9	9953VK03
4	4,5	3,4	M 4	M 6	22	60	130	6	4,9	8,4	9951V04	8,4	10	9	9953VK04
5	6	4,9	M 4,5 - M 6	M 8	25	60	130	7	5,5	12,1	9951V05	12,1	13,5	12	9953VK05
6	7	5,5	M 7	M 9 - M10	25	60	130	7	5,5	12,1	9951V06	12,1	13,5	12	9953VK06
7	8	6,2	M 8	M11	29	60	130	8	6,2	13	9951V07	13	14,5	13	9953VK07
8	9	7	M 9	M12	30	60	130	9	7	15	9951V08	15	16,5	15	9953VK08
9	10	8	M10	-	32	60	130	10	8	15	9951V09	15	16,5	15	9953VK09
10	11	9	-	M14	35	90	180	11	9	18	9951V10	18	20	18	9953VK10
11	12	9	(M12)	M16	35	90	180	12	9	18	9951V11	18	20	18	9953VK11
12	14	11	-	M18	39	90	180	14	11	22	9951V12	22	25	22	9953VK12
13	16	12	-	M20	40	90	180	16	12	22	9951V13	22	25	22	9953VK13
14	18	14,5	-	M22 - M24	42	100	200	18	14,5	26	9951V14	26	29	26	9953VK14
15	20	16	-	M27	44	100	200	20	16	28	9951V15	28	32	28	9953VK15
16	22	18	-	M30	46	100	200	22	18	30	9951V16	30	34	30	9953VK16
17	25	20	-	M33	49	100	200	25	20	35	9951V17	35	41	36	9953VK17

Schaftverlängerungen, lange Ausführung

Shank extensions, long design | Allonges porte-tarauts, version longue | Prolunghe speciali, esecuzione lunga

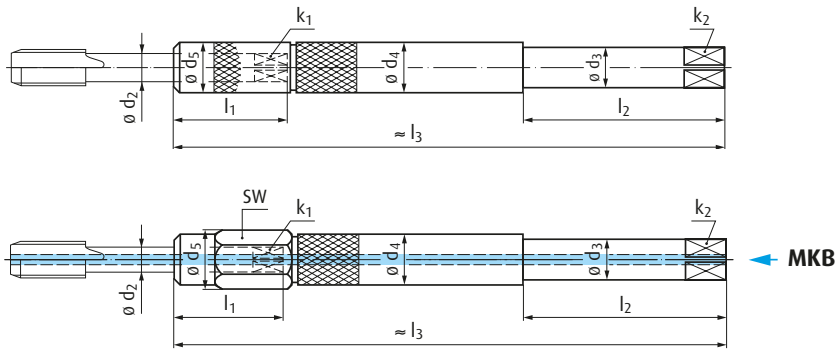

Für den Einsatz auf herkömmlichen Gewindeschneideinrichtungen
 For use on CNC machines and conventional thread cutting machinery
 Pour utilisation sur machines CNC et tous dispositifs de taraudage conventionnels
 Per l'impiego su macchina CNC ed apparecchiature a filettare tradizionali

Größe Size Taille Grand.	Baumaße Gewindebohrer Dimensions of tap Dimensions taraud Dimensioni maschio				Baumaße Schaftverlängerung Dimensions of extensions Dimensions allonge porte-taraut Dimensioni prolunga						MKB				
	d ₂	k ₁	DIN 371	DIN 374/376	l ₁	l ₂	l ₃	d ₃	k ₂	d ₄ /d ₅		d ₄	d ₅	SW	
1	2,8	2,1	M 2 - M2,6	M4	21	70	230	6	4,9	6,1	9952V01	6,1	6,5	6	9954VK01
2	3,5	2,7	M 3	M 4,5 - M 5	22	70	230	6	4,9	7,5	9952V02	7,5	9	8	9954VK02
3	4	3	M 3,5	M 5,5	22	70	230	6	4,9	8,4	9952V03	8,4	10	9	9954VK03
4	4,5	3,4	M 4	M 6	22	70	230	6	4,9	8,4	9952V04	8,4	10	9	9954VK04
5	6	4,9	M 4,5 - M 6	M 8	25	70	230	7	5,5	12,1	9952V05	12,1	13,5	12	9954VK05
6	7	5,5	M 7	M 9 - M10	25	70	230	7	5,5	12,1	9952V06	12,1	13,5	12	9954VK06
7	8	6,2	M 8	M11	29	80	230	8	6,2	13	9952V07	13	14,5	13	9954VK07
8	9	7	M 9	M12	30	80	230	9	7	15	9952V08	15	16,5	15	9954VK08
9	10	8	M10	-	32	80	230	10	8	15	9952V09	15	16,5	15	9954VK09
10	11	9	-	M14	35	90	330	11	9	18	9952V10	18	20	18	9954VK10
11	12	9	(M12)	M16	35	90	330	12	9	18	9952V11	18	20	18	9954VK11
12	14	11	-	M18	39	90	330	14	11	22	9952V12	22	25	22	9954VK12
13	16	12	-	M20	40	90	330	16	12	22	9952V13	22	25	22	9954VK13
14	18	14,5	-	M22 - M24	42	100	330	18	14,5	26	9952V14	26	29	26	9954VK14
15	20	16	-	M27	44	100	330	20	16	28	9952V15	28	32	28	9954VK15
16	22	18	-	M30	46	100	330	22	18	30	9952V16	30	34	30	9954VK16
17	25	20	-	M33	49	100	330	25	20	35	9952V17	35	41	36	9954VK17

UNSERE PRÄZISION IST IHR ERFOLG
OUR PRECISION IS YOUR SUCCESS

GEWINDEFORMER

Cold forming taps

Tarauds à refouler

Maschi a rullare

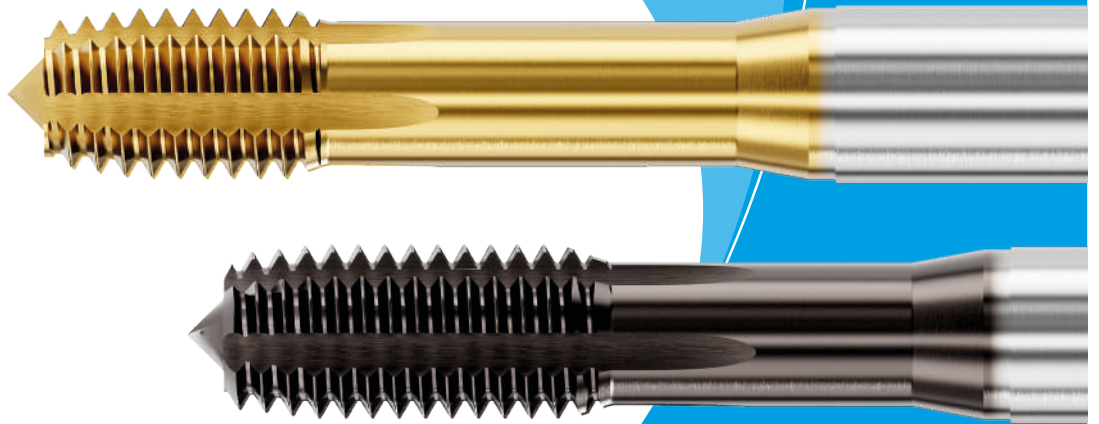



AUSWAHLÜBERSICHT

DIE ANGEGEBENEN SCHNITTGESCHWINDIGKEITEN (VC IN M/MIN) SIND RICHTWERTE UND MÜSSEN DEN INDIVIDUELLEN ARBEITSBEDINGUNGEN ANGEPASST WERDEN.



GUIDE DE SELECTION

LES VALEURS DE VITESSE DE COUPE (VC EN M/MIN) INDIQUÉES DANS LES COLONNES RESPECTIVES NE SONT QU'INDICATIVES ET DOIVENT ÊTRE ADAPTÉES INDIVIDUELLEMENT AUX CONDITIONS D'USINAGE.



SUMMARY OF ASSORTMENT

THE LISTED CUTTING SPEEDS (VC IN M/MIN) ARE STANDARD VALUES. THIS VALUES HAVE TO BE ADJUSTED TO INDIVIDUAL WORK CONDITIONS.



SCelta DEGLI UTENSILI

I VALORI DI VELOCITÀ DI TAGLIO (VC IN M/MIN) QUI ELENCATI SONO PURAMENTE INDICATIVI E DEVONO ESSERE ADATTATI ALLE CONDIZIONI D'IMPIEGO.



	STAHLWERKSTOFFE	STEEL MATERIALS	ACIERS	ACCIAI
P	Un- und niedriglegierte Stähle	Unalloyed and low-alloy steels	Aciers non et faiblement alliés	Acciai non legati e basso legati
	Hochlegierte Stähle	High alloy steels	Aciers hautement alliés	Acciai alto legati
M	ROSTFREI STÄHLE	CORROSION AND ACID PROOF STEELS	ACIERS INOX/RESIST. ACIDES	ACCIAI INOX E RESISTENTI AGLI ACIDI
	Rostfreie austenitische Stähle + DUPLEX Stähle	Corrosion and acid proof steels + DUPLEX	Aciers inoxydables austénitiques + Aciers DUPLEX	Acciai inossidabili austenitici + Acciai DUPLEX
K	GUSSWERKSTOFFE	CAST MATERIALS	FONTES	GHISE
	Grauguss, Kugelgraphitguss, Vermiculargraphitguss, Temperguss	Cast iron, nodular cast iron, Vermicular graphite cast iron, malleable cast iron	Fonte grise, fonte à graphite sphéroïdal, fonte à graphite vermiculaire, fonte malléable	Ghisa grigia, ghisa nodulare, Ghisa a grafite vermiculata, ghisa malleabile
	Gusseisen ausferritisch (ADI) + Hartguss	Ausferritic cast iron (ADI) + Hard casting	fonte austéritaire (ADI) + Fontes trempées	Ghisa ausferritica (ADI) + Ghise in conchiglia
N	NICHTEISEN-WERKSTOFFE	NON FERROUS MATERIALS	MATÉRIAUX NON FERREUX	MATERIALI NON FERROSI
	Aluminium-Knetlegierungen	Aluminium wrought alloys	Alliages d'aluminium corroyés	Leghe malleabili di alluminio
	Aluminium-Gusslegierungen	Aluminium cast alloys	Fontes d'alu	Leghe fuse di alluminio
	Kupfer + Kupferlegierungen (langsp.)	Copper + Copper alloys (long-chip.)	Cuivre + Alliages cuivre (cop. longs)	Rame + Leghe rame (truciolo lungo)
	Kupferlegierungen (kurzsp.)	Copper alloys (short-chip.)	Alliages cuivre (cop. courts)	Leghe rame (truciolo corto)
	Kupferlegierungen hochfest	High-strength copper alloys	Alliages cuivre haute résistance	Leghe rame ad alta resistenza
	Zink-Legierungen	Zinc alloys	Alliages de zinc	Leghe zinco
Magnesium-Legierungen	Magnesium wrought alloys	Alliages de magnésium corroyés	Leghe malleabili di magnesio	
Thermoplaste	Thermoplastics	Thermoplastiques	Resine termoplastiche	
Faserverstärkte Kunststoffe + Duroplaste	Fibre-reinforced synthetics + Duroplastics	Plastiques chargées en fibres + Thermodurcissables	Resine eposidiche + Plastiche termoindurenti	
S	SPEZIALWERKSTOFFE	SPECIAL MATERIALS	MATÉRIAUX SPÉCIAUX	MATERIALI SPECIALI
	Ni-, Fe- oder Co-Basis-Superlegierungen	Ni-, Fe- or Co-base-Superalloys	Base Ni, Fe ou Co-Superalliages	A base Ni-, Fe- o Co-Superleghe
	Titan + Titanlegierungen	Titanium + Titanium alloys	Titane + Alliages de titane	Titanio + Leghe di titanio
H	GEHÄRTETE WERKSTOFFE	HARDENED STEELS	ACIERS TRAITÉS	ACCIAI TEMPRATI
	Gehärtete Stähle	Hardened steels	Aciers traités	Acciai temprati

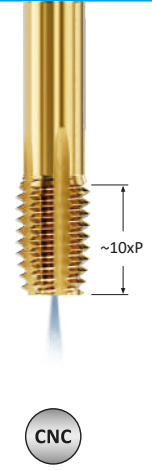
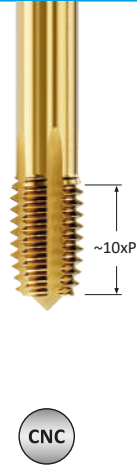
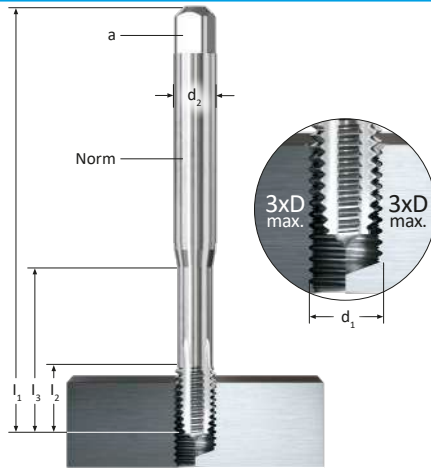

OBERFLÄCHE / SURFACE SURFACE / SUPERFICIE										TIN					
SCHNEIDSTOFF / MATERIAL MATIÈRE / MATERIALE										HSSE-PM					
ANSCHNITTFORM / CHAMFER FORM FORME D'ENTRÉE / FORMA D'IMBOCCO										C / 2-3		E / 1,5-2	C / 2-3		E / 1,5-2
d ₁	P		NORM	l ₁	l ₂	l ₃	d ₂	a		ISO2X	ISO3X	ISO2X	ISO2X	ISO2X	
M 3	0,5	2,8	2174	56	6	18	3,5	2,7		69BCB0882	69BCK00287	69BCK00292			
M 4	0,7	3,7	2174	63	7	21	4,5	3,4		69BCB0883	69BCK00288	69BCS0534930	69CCK00320	69CCS0543903	
M 5	0,8	4,65	2174	70	8	25	6	4,9		69BCB0884	69BCK00289	69BCK00293	69CCB0888	69CCK00324	
M 6	1	5,6	2174	80	10	30	6	4,9		69BCB0885	69BCK00290	69BCK00294	69CCB0889	69CCS0543907	
M 8	1,25	7,45	2174	90	14	35	8	6,2		69BCB0886	69BCF0048	69BCK00295	69CCB0890	69CCS0543910	
M 10	1,5	9,35	2174	100	16	39	10	8		69BCB0887	69BCK00291	69BCK00296	69CCB0891	69CCK00327	
M 12	1,75	11,25	2174	110	18	-	9	7		79BCB0910		79BCK00344	79CCB0912	79CCK00360	
M 14	2	13,1	2174	110	20	-	11	9				79BCK00345	79CCK00358	79CCK00361	
M 16	2	15,1	2174	110	22	-	12	9		79BCB0911		79BCK00346	79CCB0913	79CCK00362	
M 20	2,5	18,85	2174	140	25	-	16	12					79CCF0009		
M 24	3	22,65	2174	160	30	-	18	14,5							
M 30	3,5	28,4	2174	180	35	-	22	18							
										ISO2X		ISO2X			
MF 8 x	1	7,6	2174	90	10	35	8	6,2		69BCF0016			69CCB0892		
MF 10 x	1	9,6	2174	90	10	35	10	8		69BCF0017			69CCB0893		
MF 10 x	1,25	9,45	2174	100	14	39	10	8		69BCF0018					
MF 12 x	1,5	11,35	2174	100	16	-	9	7		79BCF0005			79CCB0914		
MF 14 x	1,5	13,35	2174	100	16	-	11	9		79BCF0006			79CCB0915		
MF 16 x	1,5	15,35	2174	100	16	-	12	9		79BCF0007			79CCB0916		

NORIS SPANLOS NEO

BL

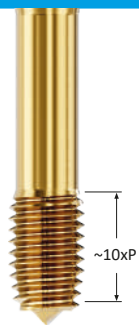

HR SN

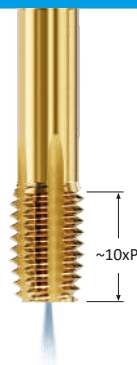

TIN	TIN			
HSSE-PM	HSSE-PM			
D / 4-5	C / 2-3			
ISO2X	ISO2X	ISO2X	d ₁	P
69ABF0004			M 3	0,5
69ABF0005			M 4	0,7
69ABF0002	69B3D00297	69C3D00301	M 5	0,8
69ABF0006	69B3D00298	69C3D00302	M 6	1
69ABF0003	69B3D00299	69C3D00303	M 8	1,25
69ABF0001	69B3D00300	69C3D00304	M 10	1,5
	79B3D00309	79C3D00314	M 12	1,75
			M 14	2
	79B3D00310	79C3D00315	M 16	2
	79B3F0001	79C3S0525444	M 20	2,5
	79B3F0003	79C3S0598467	M 24	3
		79C3F0003	M 30	3,5
	ISO2X	ISO2X		
			MF 8	x 1
			MF 10	x 1
			MF 10	x 1,25
	79B3D00311	79C3D00316	MF 12	x 1,5
	79B3D00312	79C3D00317	MF 14	x 1,5
	79B3D00313	79C3D00318	MF 16	x 1,5

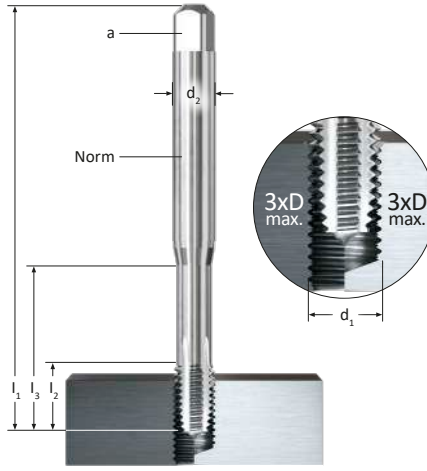

OBERFLÄCHE / SURFACE SURFACE / SUPERFICIE										DLC				TICN			
SCHNEIDSTOFF / MATERIAL MATIÈRE / MATERIALE										HSSE-PM				HSSE-PM			
ANSCHNITTFORM / CHAMFER FORM FORME D'ENTRÉE / FORMA D'IMBOCCO										C / 2-3	E / 1,5-2	C / 2-3	E / 1,5-2	C / 2-3	E / 1,5-2	C / 2-3	E / 1,5-2
d ₁	P		NORM	l ₁	l ₂	l ₃	d ₂	a		ISO2X	ISO2X	ISO2X	ISO2X	ISO2X	ISO2X	ISO2X	ISO2X
M 2	0,4	1,85	2174	45	4	12	2,8	2,1		69B1K00274	69B1K00280						
M 3	0,5	2,8	2174	56	6	18	3,5	2,7		69B1K00275	69B1K00281						
M 4	0,7	3,7	2174	63	7	21	4,5	3,4		69B1K00276	69B1K00282	69C1K00306	69C1K00310				
M 5	0,8	4,65	2174	70	8	25	6	4,9		69B1K00277	69B1K00283	69C1K00307	69C1K00311	69BGK00297	69BGK00301	69CGK00305	69CGK00331
M 6	1	5,6	2174	80	10	30	6	4,9		69B1F0005	69B1K00284	69C1F0001	69C1S0089015	69BGK00298	69BGK00302	69CGK00328	69CGF0003
M 8	1,25	7,45	2174	90	14	35	8	6,2		69B1K00278	69B1K00285	69C1K00308	69C1K00312	69BGK00299	69BGK00303	69CGK00329	69CGF0004
M 10	1,5	9,35	2174	100	16	39	10	8		69B1K00279	69B1K00286	69C1K00309	69C1K00313	69BGK00300	69BGK00304	69CGK00330	69CGK00334

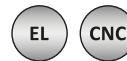
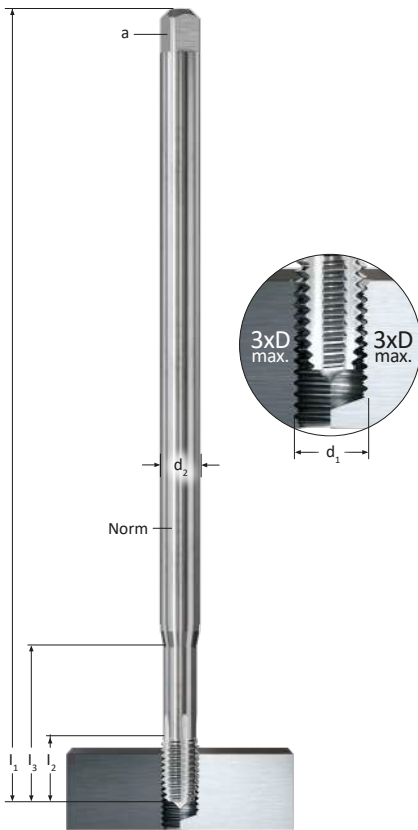

OBERFLÄCHE / SURFACE SURFACE / SUPERFICIE										TIN	
SCHNEIDSTOFF / MATERIAL MATIÈRE / MATERIALE										HSSE-PM	
ANSCHNITTFORM / CHAMFER FORM FORME D'ENTRÉE / FORMA D'IMBOCCO										C / 2-3	
d_1	P		NORM	l_1	l_2	l_3	d_2	a	ISO2X		
M 3	0,5	2,8	-	100	6	18	3,5	2,7	69BCD00319		
M 4	0,7	3,7	-	125	7	21	4,5	3,4	69BCD00320		
M 5	0,8	4,65	-	140	8	25	6	4,9	69BCD00321		
M 6	1	5,6	-	160	10	30	6	4,9	69BCD00322		
M 8	1,25	7,45	-	180	14	35	8	6,2	69BCD00323		
M 10	1,5	9,35	-	200	16	39	10	8	69BCD00324		
M 12	1,75	11,25	-	224	18	-	9	7	79BCD00325		
M 16	2	15,1	-	224	22	-	12	9	79BCD00326		

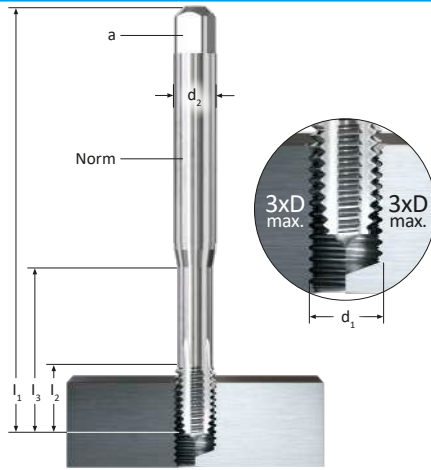

OBERFLÄCHE / SURFACE
SURFACE / SUPERFICIE

TIN

ALTiNHD

SCHNEIDSTOFF / MATERIAL
MATIÈRE / MATERIALE

HSSE

HSSE

ANSCHNITTFORM / CHAMFER FORM
FORME D'ENTRÉE / FORMA D'IMBOCCO

C / 2-3

C / 2-3

d ₁	P	NORM	l ₁	l ₂	l ₃	d ₂	a	ISO2X	ISO3X	ISO2X	
M 1	0,25	0,9	2174	40	5	-	2,5	2,1	6960ABAAA ¹⁾		
M 1,2	0,25	1,1	2174	40	5	-	2,5	2,1	6960ABBAA ¹⁾		
M 1,4	0,3	1,28	2174	40	5	-	2,5	2,1	6960ABCAA ¹⁾		
M 1,6	0,35	1,47	2174	40	6	11	2,5	2,1	6960ABDAA		
M 1,7	0,35	1,57	2174	40	6	11	2,5	2,1	6960ABEAA		
M 2	0,4	1,85	2174	45	7	12	2,8	2,1	6970AAKAA		
M 2,5	0,45	2,33	2174	50	9	14	2,8	2,1	6970AAMAA		
M 3	0,5	2,8	2174	56	11	18	3,5	2,7	6970AAAAA	6970AASAA	6970B0931
M 3,5	0,6	3,25	2174	56	12	20	4	3	6970AAPAA		
M 4	0,7	3,7	2174	63	13	21	4,5	3,4	6970AABAA	6970AATAA	6970B0932
M 5	0,8	4,65	2174	70	15	25	6	4,9	6970AACAA	6970AAHAA	6970B0933
M 6	1	5,6	2174	80	17	30	6	4,9	6970AADAA	6970AAUAA	6970B0934
M 8	1,25	7,45	2174	90	20	35	8	6,2	6970AAEAA	6970AAGAA	6970B0935
M 10	1,5	9,35	2174	100	22	39	10	8	6970AAFVA	6970AAVAA	6970B0936
M 12	1,75	11,25	2174	110	24	-	9	7	7970AADAA		7970F0044
M 14	2	13,1	2174	110	26	-	11	9	7970ACQAA		
M 16	2	15,1	2174	110	27	-	12	9	7970AAEAB		7970F0086
									ISO2X		
MF 4	x 0,5	3,8	2174	63	10	21	4,5	3,4	6970A4961		
MF 5	x 0,5	4,8	2174	70	11	25	6	4,9	6970A4962		
MF 6	x 0,5	5,8	2174	80	13	30	6	4,9	6970A4965		
MF 6	x 0,75	5,7	2174	80	13	30	6	4,9	6970F0043		
MF 8	x 1	7,6	2174	90	17	35	8	6,2	6970A4969		
MF 8	x 0,75	7,7	2174	80	14	30	8	6,2	6970F0037		
MF 10	x 1	9,6	2174	90	18	35	10	8	6970F0042		
MF 12	x 1	11,6	2174	100	18	-	9	7	7970AANAA		
MF 12	x 1,5	11,35	2174	100	22	-	9	7	7970AAQAA		
MF 14	x 1,5	13,35	2174	100	22	-	11	9	7970ABYAA		
MF 16	x 1	15,6	2174	100	18	-	12	9	7970A4976		
MF 16	x 1,5	15,35	2174	100	22	-	12	9	7970AARAA		
MF 20	x 1,5	19,35	2174	125	25	-	16	12	7970AATAA		

¹⁾ ≤ M1,4 Tol. ISO 1 / ISO 1X

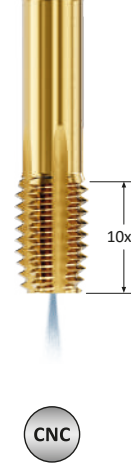
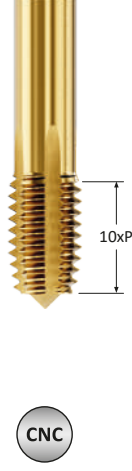
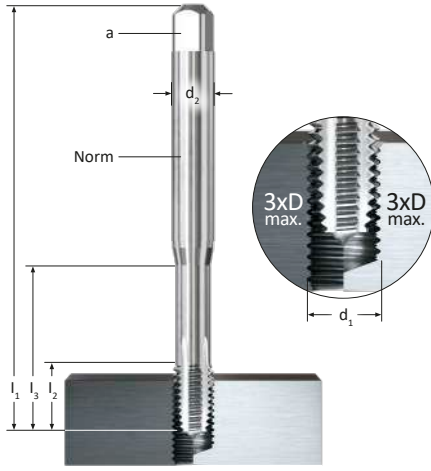

OBERFLÄCHE / SURFACE SURFACE / SUPERFICIE										TIN					
SCHNEIDSTOFF / MATERIAL MATIÈRE / MATERIALE										HSSE-PM					
ANSCHNITTFORM / CHAMFER FORM FORME D'ENTRÉE / FORMA D'IMBOCCO										C / 2-3		C / 2-3		C / 2-3	
d_1	- P/1"		NORM	l_1	l_2	l_3	d_2	a	2BX	2BX	2BX				
UNC NR 4	- 40	2,55	≈ 2174	56	11	18	3,5	2,7	69BCF0012		6970AAZAA				
UNC NR 6	- 32	3,15	≈ 2174	56	12	20	4	3	69BCF0034		6970AA1AA				
UNC NR 8	- 32	3,8	≈ 2174	63	13	21	4,5	3,4	69BCF0035		6970AA2AA				
UNC NR 10	- 24	4,35	≈ 2174	70	15	25	6	4,9	69BCF0036	69CCK00321	6970AA3AA				
UNC 1/4	- 20	5,75	≈ 2174	80	17	30	7	5,5	69BCF0037	69CCK00314	6970AA5AA				
UNC 5/16	- 18	7,3	≈ 2174	90	20	35	8	6,2	69BCF0038	69CCK00318	6970AA6AA				
UNC 3/8	- 16	8,8	≈ 2174	100	22	39	10	8	69BCF0039	69CCK00316	6970AA7AA				
UNC 7/16	- 14	10,25	≈ 2174	100	22	-	8	6,2	79BCF0019	79CCK00352	7970A4993				
UNC 1/2	- 13	11,8	≈ 2174	110	25	-	9	7	79BCF0020	79CCK00348	7970A4994				
UNC 5/8	- 11	14,8	≈ 2174	110	27	-	12	9	79BCK00343	79CCK00351	7970A4997				
UNC 3/4	- 10	17,85	≈ 2174	125	30	-	14	11	79BCK00342	79CCK00350	7970A4998				
									2BX	2BX	2BX				
UNF NR 2	- 64	2,02	≈ 2174	45	7	12	2,8	2,1			6970A5000				
UNF NR 4	- 48	2,62	≈ 2174	56	11	18	3,5	2,7			6970ABAAA				
UNF NR 6	- 40	3,22	≈ 2174	56	12	20	4	3	69BCF0040		6970ABCAA				
UNF NR 8	- 36	3,85	≈ 2174	63	13	21	4,5	3,4	69BCF0041		6970ABDAA				
UNF NR 10	- 32	4,45	≈ 2174	70	15	25	6	4,9	69BCF0042	69CCK00322	6970ABEAA				
UNF 1/4	- 28	5,95	≈ 2174	80	17	30	7	5,5	69BCF0043	69CCK00315	6970ABGAA				
UNF 5/16	- 24	7,45	≈ 2174	90	17	35	8	6,2	69BCF0032	69CCK00319	6970A5009				
UNF 3/8	- 24	9,05	≈ 2174	90	18	35	10	8	69BCF0002	69CCK00317	6970F0038				
UNF 7/16	- 20	10,55	≈ 2174	100	22	-	8	6,2	79BCF0002	79CCK00353	7970AAHAA				
UNF 1/2	- 20	12,15	≈ 2174	100	22	-	9	7	79BCF0021	79CCK00349	7970AAIAA				
UNF 5/8	- 18	15,25	≈ 2174	100	22	-	12	9			7970A5017				
UNF 3/4	- 16	18,35	≈ 2174	110	25	-	14	11			7970A5018				

G DIN EN ISO 228

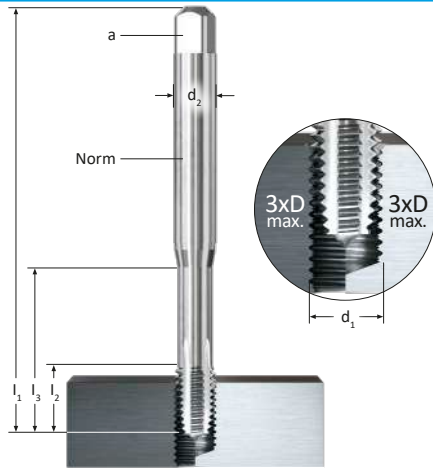

NORIS SPANLOS NEO CNC SN

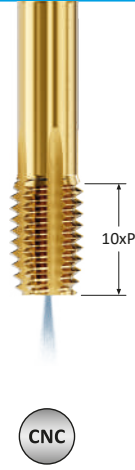
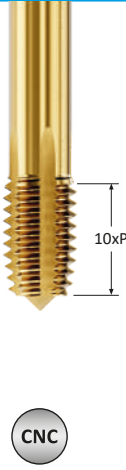

EC SN



OBERFLÄCHE / SURFACE SURFACE / SUPERFICIE										TIN					
SCHNEIDSTOFF / MATERIAL MATIÈRE / MATERIALE										HSSE-PM					
ANSCHNITTFORM / CHAMFER FORM FORME D'ENTRÉE / FORMA D'IMBOCCO										C / 2-3		C / 2-3		C / 2-3	
d ₁	- P/1"		NORM	l ₁	l ₂	l ₃	d ₂	a		ISO 228 X	ISO 228 X	ISO 228 X			
G	1/8	- 28	9,25	2189	90	18	-	7	5,5	79BCF0015	79CCK00356	7970AAUAA			
G	1/4	- 19	12,55	2189	100	22	-	11	9	79BCF0016	79CCK00355	7970AAVAA			
G	3/8	- 19	16,05	2189	100	22	-	12	9	79BCF0017	79CCK00357	7970AAWAA			
G	1/2	- 14	20,10	2189	125	25	-	16	12	79BCF0018	79CCK00354	7970AAXAA			



SOLUTIONS@NORIS-REIME.DE

Das REIME Team steht Ihnen bei der Lösung Ihrer Zerspanungsaufgabe gerne zur Seite

The REIME team will be happy to solve your threading tasks

L'équipe de REIME se tient à votre disposition pour résoudre vos problèmes de filetage

Il team REIME sarà lieto di risolvere i vostri problemi di filettatura







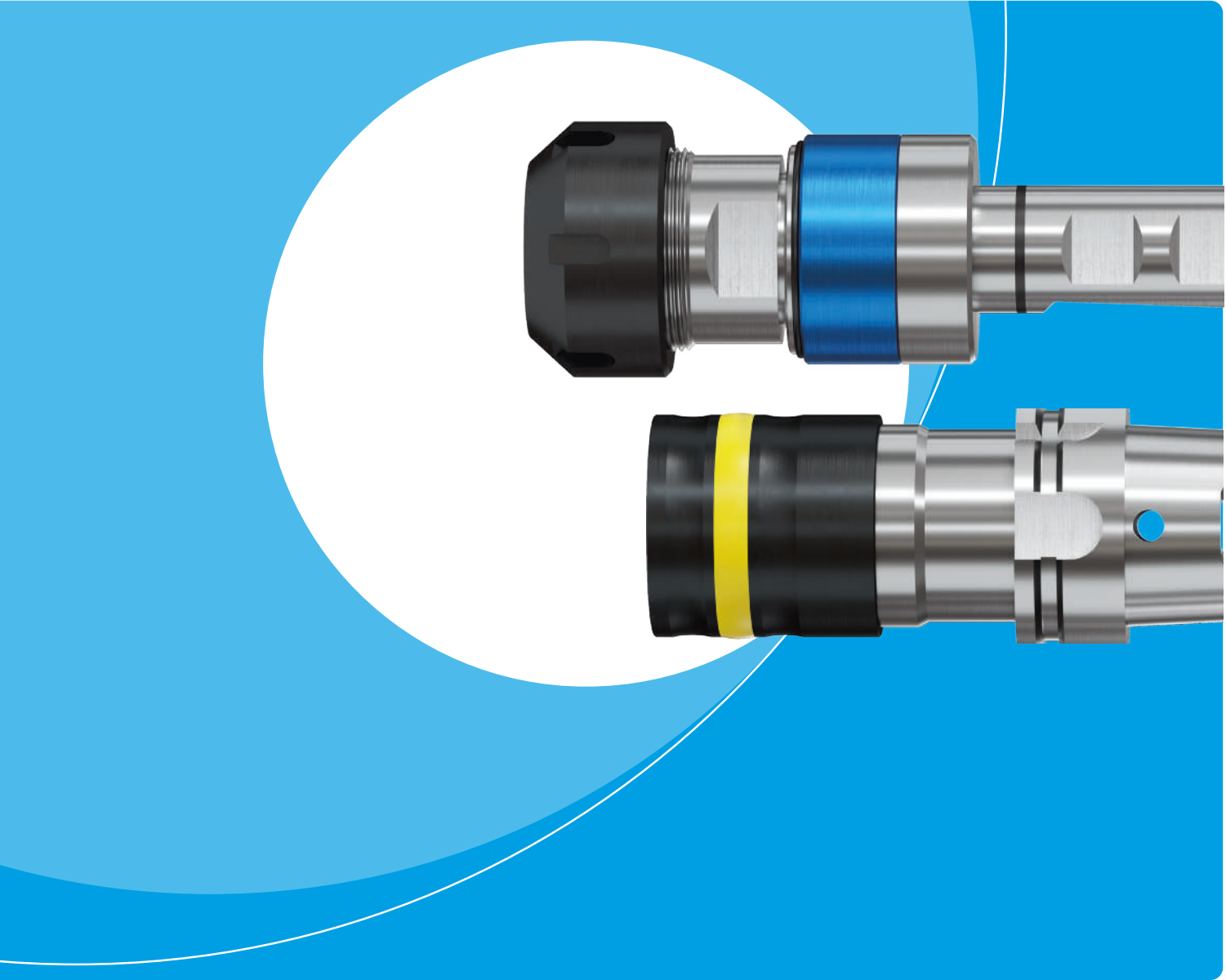















UNSERE PRÄZISION IST IHR ERFOLG
OUR PRECISION IS YOUR SUCCESS

GEWINDESCHNEIDFUTTER



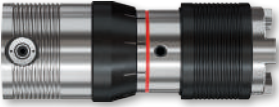



Tap holders
Mandrins de taraudage
Mandrini



AUFNAHMEN | TAP HOLDERS















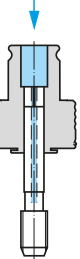

			In nere Kühlmierstoff-Zufuhr Internal coolant-lubricant supply Lubrification par le centre Lubrificazione interna	Kühlmierstoff-Druck am Futtereintritt Coolant-lubricant pressure at the entry to the holder Pression de lubrification à l'entrée du mandrin Pressione del lubrificante all'entrata del mandrino	Längenausgleich in Druck- und Zugrichtung Length compensation on compression and tension Compensation de longueur en compression et traction Compensazione longitudinale a pressione e trazione	Minimallängenausgleich Minimal length compensation Mandrino à pince à compensation de longueur minimum Mandrino portapinzze per compensazione maschiatura rigida CNC	Druckpunktmechanismus Pressure-point mechanism Mécanisme à point de poussée Meccanismo "Punto di pressione"
UNI			DIN 1835 B+E				
			DIN 69893 A				
			DIN 228 B				
UNI/HP			DIN 1835 B+E	•	•	•	•
			DIN 69893 A	•	•	•	•
UNI/HP/ER			DIN 1835 B+E	•	•	•	•
			DIN 69893 A	•	•	•	•
HelixPro			DIN 1835 B+E	•	•	•	•
			DIN 69893 A	•	•	•	•
ISP			DIN 69871 A, AD, B			•	
			DIN 2080			•	
			DIN 228 B			•	

MANDRINS DE TARAUDAGE | MANDRINI

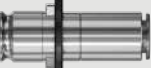

 <p>Zugausrastung Front release Declenchement à l'arrachement Rilascio a trazione</p>	 <p>Überlastkupplung Overload clutch Accouplement débrayable Frizione</p>	 <p>Bohren und Senken Drilling and countersinking Pour forage et chanfreinage Per forare e allargare</p>	 <p>Werkzeugadaptierung über Schnellwechsel-Einsätze, Type WE Tool adaptation by means of quick-change adapters type WE Montage de l'outil avec adaptateurs à changement rapide type WE Serraggio dell'utensile tramite bussole a cambio rapido tipo WE</p>	 <p>Werkzeugadaptierung über Schnellwechsel-Einsätze Typ IE Tool adaptation by means of quick-change adapters type IE Montage de l'outil avec adaptateurs à changement rapide type IE Serraggio dell'utensile tramite bussole a cambio rapido tipo IE</p>	 <p>Werkzeugadaptierung über Schnellwechsel-Einsätze Typ ER Tool adaptation by means of collets type ER Serrage d'outils par pinces type ER Serraggio dell'utensile tramite pinze tipo ER</p>	<p>Einsatz auf Maschinen mit Synchronspindel For use on machines with synchronous spindle Utilisation sur machines avec broche synchronisée Impiego su macchine con mandrino sincronizzato</p>	<p>Einsatz auf CNC-Bearbeitungszentren und sonstigen Werkzeugmaschinen For use on CNC machining centres and other machine tools Pour utilisés sur centres d'usinage CNC, tours CNC et machines classiques Per centri di lavoro CNC, torni CNC ed altre macchine utensili classiche</p>	<p>Einsatz auf Säulenbohrmaschinen For use on pillar drilling machines Utilisation sur perceuses à colonne Impiego su trapani a colonna</p>
•			•				•	•
•			•				•	•
•			•				•	•
•			•				•	•
•			•				•	•
					•		•	
					•		•	
					•	•		
					•	•		
	•	•		•			•	•
	•	•		•			•	•
	•	•		•			•	•

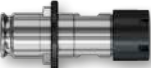





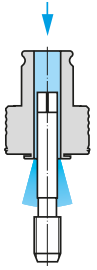



SCHNELLWECHSEL-EINSÄTZE | QUICK-CHANGE ADAPTERS

		DIN	ISO	 <p>Schnellwechsel-Kugelspannsystem oder Klemmung am Vierkant Quick-change ball clamping system or clamping on the square Système de serrage à billes à changement rapide ou serrage sur le carré Sistema di serraggio a sfere a cambio rapido o serraggio sul quadro</p>	 <p>Spannzangen, Typ ER Collets type ER Pincas type ER Pinze tipo ER</p>	 <p>Überlastkupplung Overload clutch Accouplement débrayable Frizione</p>	 <p>Längennachstellung Length adjustment Réglage de longueur Regolazione della lunghezza</p>	 <p>durch das Zentrum des Werkzeugs through the tool axis avec canal interne attraverso l'utensile</p>
WE		122	123	•				•
WE-E		122	123	•				•
WE/MKBA		124	–	•				
WE-U		126	127	•		•		•
WE-U-E		128	128	•		•		•
WE-U/MKBA		129	–	•		•		
WE-L		130	131	•			•	•
WE-L-E		132	132	•			•	•
WE-UL		133	134	•		•	•	•
WE-UL-E		135	135	•		•	•	•
WE-L/ER/ MKB		136	–		•		•	•
WE-R		137	–	•				
ER / ER-GB		120	–		•			

ADAPTATEURS À CHANGEMENT RAPIDE | BUSSOLE A CAMBIO RAPIDO

<p>entlang des Werkzeugschafts along the tool shank le long de la queue d'outil lungo il gambo dell'utensile</p> 	<p>Grundlochgewinde Blind hole threads Taraudage de trous borgnes Filettatura di fori ciechi</p> 	<p>Durchgangslöschgewinde Through hole threads Taraudage de trous débouchant Filettatura di fori passanti</p> 	<p>Regelgewinde Coarse thread Filetage à pas gros Filettatura grossa</p>	<p>Feingewinde Fine thread Filetage à pas fin Filettatura fini</p>	<p>Spannen von Vollhartmetall-Werkzeugen Clamping of solid carbide tools Serrage d'outils en carbure monobloc Serraggio di utensili in metallo duro integrale</p>	<p>Hochgeschwindigkeitsbearbeitung High-speed machining Usinage à grande vitesse Lavorazione ad alta velocità</p>	<p>hoher Kühlschmierstoff-Druck high coolant-lubricant pressure Pression de lubrifiant élevée Alta pressione del lubrificante</p>	<p>Einsatz auf Mehrspindelmaschinen und Transferstraßen for use on multi-spindle machines and transfer lines Utilisation sur machines multi-broches et lignes transfert Impiego su macchine multi-mandrino e linee transfer</p>
		•	•					
		•	•	•				
•		•	•					
	•		•					
	•			•				
•	•		•					
		•	•					•
		•		•				•
	•		•					•
	•			•				•
•		•	•		•		•	•
	•	•	•					



		
	<p>Innere Kühlschmierstoff-Zufuhr</p> <p>Das Herstellen von Gewinden auf Werkzeugmaschinen, deren Spindeln mit innerer Kühlschmierstoff-Zufuhr ausgestattet sind, gestaltet sich besonders wirtschaftlich, wenn der Kühlschmierstoff durch eine axiale Bohrung im Werkzeug bzw. entlang des Werkzeugschafts austritt.</p> <p>Die Vorteile sind:</p> <ul style="list-style-type: none"> • optimale Schmierung an der Werkzeugschneide • Verbesserung der Gewindegüte • Herausschwemmen der Späne aus der Kernlochbohrung 	<p>Internal coolant-lubricant supply</p> <p>Thread production on machine tools whose spindles are provided with internal coolant-lubricant supply can be done on the highest level of economic efficiency if the coolant-lubricant is transported through an axial bore inside the tool or along the tool shank.</p> <p>The advantages of this arrangement are:</p> <ul style="list-style-type: none"> • perfect lubrication at the cutting edge of the tool • improved thread quality • chips are washed out of the thread hole
	<p>Kühlschmierstoff-Druck am Futtereintritt</p> <p>Zur Sicherstellung der störungsfreien Funktion der Werkzeug-Aufnahme darf der angegebene Kühlschmierstoff-Druck nicht überschritten werden.</p>	<p>Coolant-lubricant pressure at the entry to the holder</p> <p>For the sake of trouble-free operation of the tool holders, it is vital not to exceed the specified maximum coolant-lubricant pressures.</p>
	<p>Längenausgleich in Druck- und Zugrichtung</p> <p>Durch diesen Längenausgleich werden Differenzen zwischen Spindelvorschub und Steigung des herzustellenden Gewindes kompensiert.</p>	<p>Length compensation on compression and tension</p> <p>The length compensation compensates differences between spindle feed and the pitch of the thread to be produced.</p>
	<p>Minimallängenausgleich</p> <p>Durch den Einbau eines Minimallängenausgleiches in Druck- und Zugrichtung werden auftretende Minimalsteigungsdifferenzen zwischen Synchronspindel und dem Werkzeug, die zu hohen Gewindeflankenreibräften führen würden, ausgeglichen. Eine eventuelle Axialkrafthöhung während des Gewindeherstellzykluses wird auf ein Minimum reduziert.</p> <p>Die Vorteile sind:</p> <ul style="list-style-type: none"> • kein Verschneiden der Gewinde • optimierte Standzeit des Werkzeugs • geeignet für innere Kühlschmierstoff-Zufuhr 	<p>Minimal length compensation</p> <p>An integrated minimal length compensation on compression and tension compensates minimal pitch differences between synchronous spindle and tool which would lead to excessive friction forces on the thread flanks. A possible increase of axial force during the thread production cycle is reduced to a minimum.</p> <p>The advantages of this arrangement are:</p> <ul style="list-style-type: none"> • no miscut threads • optimised tool life • suitable for internal coolant-lubricant supply
	<p>Druckpunktmechanismus</p> <p>Der Druckpunktmechanismus stellt sicher, dass beim Einwirken der zulässigen Axialkraft das Gewindeverkzeug sofort das Gewinde anschneidet. Erst wenn die effektiv auftretende Axialkraft die normal zulässige Ansnchnitt-/ Anformkraft übersteigt, gibt der Druckpunktmechanismus die Längenausgleichsbewegung frei.</p>	<p>Pressure-point mechanism</p> <p>The pressure-point mechanism guarantees that as soon as the permissible axial force becomes effective the threading tool starts producing a thread immediately. It is only when the effective axial force exceeds the normal permissible cutting or forming force that the pressure-point mechanism allows the length compensation movement.</p>
	<p>Zugausrastung</p> <p>Die Zugausrastung schützt die Schnellwechsel-Aufnahme, den verwendeten Schnellwechsel-Einsatz und das Werkzeug, sowie das Werkstück vor Beschädigungen infolge übergroßer axialer Zugbelastungen. Diese Belastungen können auftreten, wenn der Längenausgleichsweg überschritten wird, weil z.B. die Maschinenspindel im Umkehrpunkt des Gewindeherstellzykluses nachläuft oder der Eilvorschub bei der Rückzugbewegung des Werkzeugs einsetzt, bevor das Werkzeug vollkommen aus dem Werkstück ausgetreten ist. In diesen Situationen rastet der Schnellwechsel-Einsatz automatisch aus der Schnellwechsel- Aufnahme aus und vermeidet kostspielige Schäden.</p>	<p>Front release</p> <p>The front release protects the quick-change holder, the quick-change adapter and the tool, as well as the workpiece, against damage caused by excessive axial tension. Such tension may occur if the length compensation path is exceeded due to afterrunning of the spindle at the point of reversal, or when the fast-feed function is activated before the tool has come free from the workpiece.</p> <p>In these situations, the quick-change adapter is detached from the holder automatically, avoiding expensive damage.</p>











<p>Lubrification par le centre</p> <p>Sur les machines équipées de broches avec lubrification par le centre, la production de filets est particulièrement efficace si le lubrifiant passe par le centre de l'outil ou le long de la queue d'outil.</p> <p>Les avantages sont:</p> <ul style="list-style-type: none"> • lubrification optimale sur l'arête de coupe • amélioration de la qualité de taraudage • nettoyage du trou et évacuation des copeaux 	<p>Lubrorefrigerazione interna</p> <p>Il ciclo di filettatura su macchine utensili equipaggiate con lubrorefrigerazione all'interno del mandrino, è particolarmente efficiente quando il lubrorefrigerante viene immesso attraverso un foro assiale nell'utensile oppure lungo il gambo dello stesso.</p> <p>I vantaggi sono:</p> <ul style="list-style-type: none"> • lubrorefrigerazione ottimale sul tagliente dell'utensile • miglioramento della qualità della filettatura • espulsione dei trucioli dal preforo
<p>Pression de lubrification à l'entrée du mandrin</p> <p>Pour assurer un fonctionnement normal du mandrin, la pression de lubrification ne doit pas excéder les limites préconisées.</p>	<p>Pressione del lubrorefrigerante all'entrata del mandrino</p> <p>Per assicurare la funzione del mandrino, la pressione del lubrorefrigerante non deve superare il limite indicato.</p>
<p>Compensation de longueur en compression et traction</p> <p>Les différences entre l'avance de la broche et le pas du filetage à réaliser sont absorbées par la compensation de longueur.</p>	<p>Compensazione longitudinale a pressione e trazione</p> <p>Grazie a questa compensazione longitudinale si possono compensare le differenze tra l'avanzamento del mandrino ed il passo della filettatura da realizzare.</p>
<p>Compensation de longueur minimale</p> <p>La compensation de longueur minimale en compression et traction permet d'absorber des différences de pas minimales entre la broche synchronisée et l'outil. Les forces de friction élevées sur les flancs de filet qui résultent de la force axiale liée à ces décalages sont alors réduites au minimum.</p> <p>Les avantages sont:</p> <ul style="list-style-type: none"> • pas de recoupe des filets • durée de vie optimale de l'outil • approprié pour la lubrification par le centre 	<p>Compensazione longitudinale minima</p> <p>La compensazione longitudinale minima a compressione e trazione permette di assorbire le differenze di passo minime che si creano tra il mandrino sincronizzato e l'utensile. Le forze di frizione elevate sui fianchi del filetto che risultano dalla forza assiale legata a questi spostamenti vengono così ridotte al minimo.</p> <p>I vantaggi sono:</p> <ul style="list-style-type: none"> • nessun errore di taglio assiale dei filetti • durata dell'utensile ottimale • utilizzabile per lubrorefrigerazione interna
<p>Mécanisme à point de poussée</p> <p>Le mécanisme à point de poussée assure que l'outil de taraudage coupe immédiatement sous l'action de l'avance. Dès que la force axiale effective dépasse la force d'attaque normale, le mécanisme à point de poussée active la compensation de longueur.</p>	<p>Meccanismo "Punto di pressione"</p> <p>Il meccanismo "Punto di pressione" assicura il taglio immediato della filettatura all'esercitarsi della forza assiale sull'utensile. Solo quando la forza assiale è superiore alla normale forza di taglio, il meccanismo "Punto di pressione" attiva il movimento di compensazione longitudinale.</p>
<p>Déclenchement à l'arrachement</p> <p>Le déclenchement à l'arrachement protège le mandrin de taraudage, l'adaptateur à changement rapide, l'outil ainsi que la pièce contre les dommages liés à une force en traction excessive. Cette surcharge peut intervenir lorsque la longueur nécessaire de la compensation en traction est supérieure à celle du mandrin, p.ex. lors de l'inversion du sens de la broche ou lors d'un mouvement arrière en rapide lorsque l'outil est encore engagé dans la pièce. Dans ce cas, l'adaptateur à changement rapide se dégage automatiquement du mandrin et évite toute casse onéreuse.</p>	<p>Rilascio a trazione</p> <p>Il rilascio a trazione protegge il mandrino, la bussola a cambio rapido, l'utensile ed il pezzo da danni che si possono verificare in seguito ad un eccessivo carico a trazione. Ciò può accadere quando la compensazione longitudinale viene superata in seguito, ad esempio, ad un'inversione ritardata sul ciclo di maschiatura, o ad un ritorno rapido inserito prima che l'utensile sia fuoriuscito dal pezzo. In questa situazione la bussola a cambio rapido esce automaticamente dal mandrino ed evita dei danni costosi.</p>



SYMBOLBESCHREIBUNG

DESCRIPTION OF THE SYMBOLS

		
	<p>Überlastkupplung</p> <p>Beim Überschreiten des eingestellten Drehmomentes unterbricht die Überlastkupplung die Drehmomentübertragung zwischen Maschinenspindel und Gewindebohrer während des Gewindegewindeschneidvorganges. Dadurch wird der Gewindebohrer vor Bruch geschützt, z.B. beim Auffahren auf Grund bei Grundlochgewinden.</p>	<p>Overload clutch</p> <p>When the set torque is exceeded during a threading process, the overload clutch immediately interrupts the torque transfer between machine spindle and tap. This protects the tap against damage, e.g. by running against the bottom of a blind hole.</p>
	<p>Längennachstellung</p> <p>Durch die Längennachstellung kann die Auskraglänge des Schnellwechsel-Einsatzes bei Bedarf nachgestellt/vergrößert werden.</p>	<p>Length adjustment</p> <p>With the length adjustment, the projection length of the quick-change adapter can be re-adjusted or increased in case of need.</p>
	<p>Bohren und Senken</p> <p>Durch Blockieren des Längenausgleichs über eine Arretierschraube kann die Bohr- oder Senkoperation ohne Auswechseln der Schnellwechsel-Aufnahme durchgeführt werden.</p> <p>Die Vorteile sind:</p> <ul style="list-style-type: none"> • geringe Abweichung der Koaxialität zwischen Bohrung und Gewinde • kein zeitintensives Umrüsten mit entsprechender Kostenreduzierung 	<p>Drilling and countersinking</p> <p>Drilling and countersinking operations can be done without exchanging the quick-change holder, simply by blocking the length compensation with a locking screw.</p> <p>The advantages of this arrangement are:</p> <ul style="list-style-type: none"> • alignment offset between drilled hole and thread reduced to a minimum • no time-consuming re-tooling, with according cost reduction
	<p>Werkzeugadaptierung über Schnellwechsel-Einsätze, Typenreihe WE</p> <p>Die Adaptierung der Werkzeuge erfolgt über Schnellwechsel-Einsätze der Typenreihe WE.</p>	<p>Tool adaptation by means of quick-change adapters, WE series</p> <p>The tool adaptation is effected by means of quick-change adapters of our WE series.</p>
	<p>Werkzeugadaptierung über Schnellwechsel-Einsätze, Typenreihe IE</p> <p>Die Adaptierung der Werkzeuge erfolgt über Schnellwechsel-Einsätze der Typenreihe IE. Die Klemmung des Werkzeugs erfolgt durch Gewindestifte. Für die Einsätze IE 2/MKB wird ein Anzugsmoment von 15 Nm empfohlen.</p>	<p>Tool adaptation by means of quick-change adapters, IE series</p> <p>The tool adaptation is effected by means of quick-change adapters of our IE series. The clamping of the tool is provided by threaded pins. For our adapters type IE 2/MKB, we recommend a fastening torque of 15 Nm.</p>
	<p>Werkzeugadaptierung über Spannzangen</p> <p>Die Adaptierung der Werkzeuge erfolgt über Spannzangen der Typenreihe ER bzw. ER-GB (mit integriertem Vierkant).</p>	<p>Tool adaptation by means of collets</p> <p>The tool adaptation is effected by means of collets of our ER, or our ER-GB series (with integrated square).</p>

DESCRIPTION DES SYMBOLES

DESCRIZIONE DEI SIMBOLI



<p>Accouplement débrayable</p> <p>Dès que le couple réglé est dépassé, l'accouplement débraye interrompant immédiatement la transmission du couple entre la broche machine et le taraud lors du cycle de taraudage. Cela permet de protéger le taraud contre la rupture, p.ex. en cas de contact du taraud avec le fond de trous borgnes.</p>	<p>Frizione</p> <p>Appena il momento torcente regolato è superato, la frizione ne interrompe immediatamente la trasmissione fra il mandrino macchina ed il maschio durante il ciclo di maschiatura. Ciò permette di proteggere il maschio contro la rottura, p.es. in caso di contatto del maschio con il fondo di fori ciechi.</p>
<p>Réglage de longueur</p> <p>Le réglage de longueur permet de régler/augmenter, en cas de besoin, la longueur de sortie de l'adaptateur à changement rapide.</p>	<p>Regolazione della lunghezza</p> <p>La regolazione della lunghezza permette di regolare/aumentare, in caso di bisogno, la lunghezza di sporgenza della bussola a cambio rapido.</p>
<p>Perçage et lamage</p> <p>Le blocage de la compensation de longueur au moyen de la vis d'arrêt permet de réaliser des opérations de perçage ou de lamage sans changer le mandrin.</p> <p>Les avantages sont:</p> <ul style="list-style-type: none"> • faible déviation coaxiale entre alésage et taraudage • temps d'installation réduit et diminution des coûts 	<p>Foratura e svasatura</p> <p>Il bloccaggio della compensazione longitudinale per mezzo di una vite di arresto permette di realizzare delle operazioni di foratura o svasatura senza cambio del mandrino.</p> <p>I vantaggi sono:</p> <ul style="list-style-type: none"> • deviazione assiale tra foro e filettatura ridotta al minimo • tempo d'installazione ridotto e diminuzione dei costi
<p>Montage de l'outil avec adaptateurs à changement rapide type WE</p> <p>Les outils sont montés dans des adaptateurs à changement rapide de type WE.</p>	<p>Serraggio dell'utensile tramite bussole a cambio rapido tipo WE</p> <p>L'adattamento dell'utensile avviene tramite bussole a cambio rapido WE.</p>
<p>Montage de l'outil avec adaptateurs à changement rapide, série IE</p> <p>Les outils sont montés dans des adaptateurs à changement rapide de la série IE. Le serrage d'outil s'effectue par vis sans tête. Pour les adaptateurs IE 2/MKB le couple de serrage préconisé est de 15 Nm.</p>	<p>Serraggio dell'utensile tramite bussole a cambio rapido, tipo IE</p> <p>L'adattamento dell'utensile avviene tramite bussole a cambio rapido della serie IE. Il serraggio dell'utensile è effettuato da spine filettate. Per le bussole IE 2/MKB il momento torcente di serraggio raccomandato è 15 Nm.</p>
<p>Serrage d'outils par pinces</p> <p>Les outils sont montés dans des pinces de type ER ou ER-GB (avec carré intégré).</p>	<p>Serraggio dell'utensile tramite pinze</p> <p>Il serraggio dell'utensile avviene tramite pinze tipo ER o ER-GB (con quadro interno).</p>



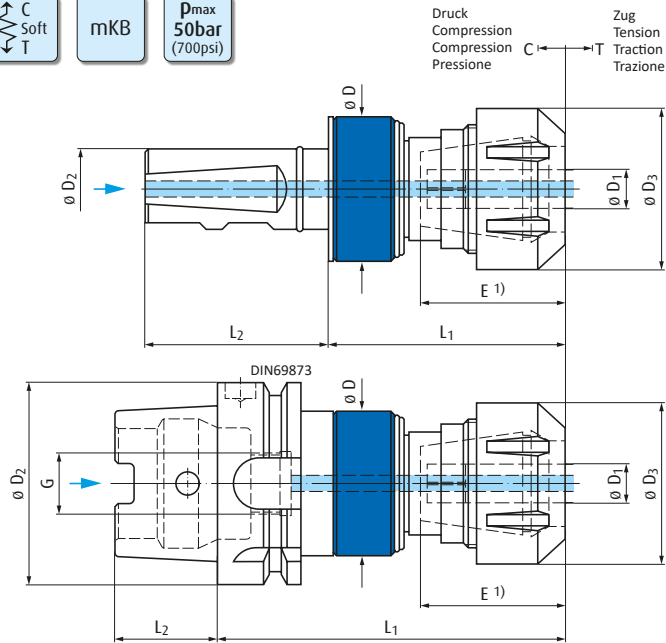

DIN 1835 B+E



DIN 69893 A

Typ Type Tipo				C	T	ø D	ø D ₃	ø D ₂	L ₁ ER	L ₁ ER-GB	L ₂		
HelixPro μ	M0,5 - M4 (Nr.0 - Nr.8)	ER 8	-	0,2	0,2	20	12	ø 10 HSK-A32	43,5 60	-	40 16	A770Z0820	A790Z0832
HelixPro 0	M2 - M8 (Nr.2 - 5/16)	ER 11 GB	-	0,5	0,5	34	16	ø 16	72,7	71	49	A770Z1116	A790Z1140 A790Z1163
								ø 20	72,7	71	51	A770Z1120	
								ø 25	72,7	71	57	A770Z1125	
								HSK-A40	89,2	87,5	20		
								HSK-A63	95,2	93,5	32		
HelixPro 1	M4 - M12 (Nr.8 - 7/16)	ER 20 GB	DS ER 20	0,5	0,5	34	34	ø 25	-	73	57	A770Z2025	A790Z2040
								HSK-A40	-	89,5	20	A790Z2050	
								HSK-A50	-	93,5	25	A790Z2063	
								HSK-A63	-	95,5	32	A790Z2080	
								HSK-A80	-	100	40	A790Z2000	
HelixPro 3	M4 - M20 (Nr.8 - 3/4)	ER 32 GB	DS ER 32	0,5	0,5	45	50	ø 25	-	87,3	57	A770Z3225	A790Z3250
								HSK-A50	-	116,3	25	A790Z3263	
								HSK-A63	-	108,8	32	A790Z3280	
								HSK-A80	-	113,3	40	A790Z3200	
								HSK-A100	-	115,3	50		
HelixPro 4	M12 - M30 (7/16 - 1 1/8)	ER 40 GB	DS ER 40	0,7	0,7	63	63	ø 32	-	113,5	61	A770Z4032	A790Z4063
								HSK-A63	-	146,5	32	A790Z4080	
								HSK-A80	-	136	40	A790Z4000	
HelixPro 5	M30 - M48 (1 3/8 - 1 3/4)	ER 50 GB	DS ER 50	2	2	103	78	HSK-A100	269	265,6	50		A790Z5000
HelixPro 6	M45 - M76 (1 3/8 - 2 3/8)	IE 2		2	2	110	75	HSK-A100	110	281	50		A790ZH200



Spannzangen und Dichtscheiben siehe Seite 120-121
Collets and sealing disks, see page 120-121
Pinces et disques d'étanchéité, voir page 120-121
Pinze di serraggio e guarnizioni, vedi pagina 120-121

UNI | UNI-HP

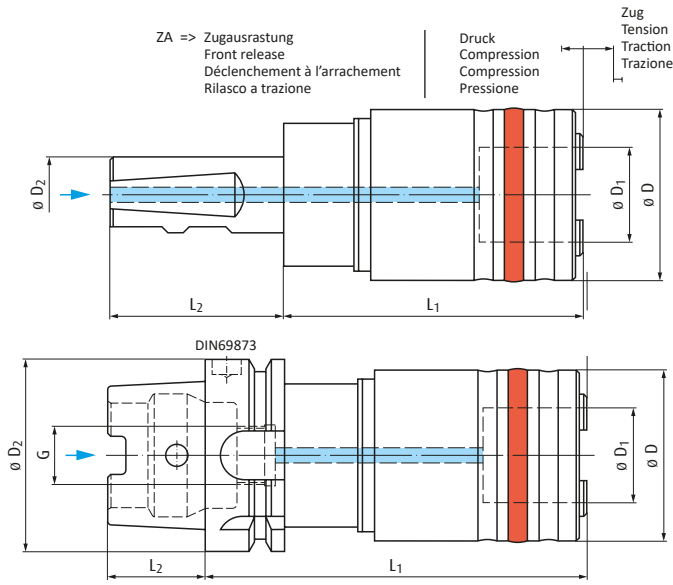
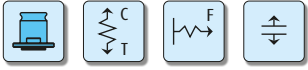

NORIS

UNI

UNI HP

mKB D_{max} 50bar (700psi)



DIN 1835 B+E

DIN 69893 A

DIN 1835 B+E

DIN 69893 A

Typ Type Tipo			$\varnothing D_2$	$\varnothing D$	L_1	L_2	C	T	Z_A				
UNI 0	M1 - M10 (Nr.0 - 3/8)	WE 00	$\varnothing 16$	26	38	49	5	7,5	1,7	A170.E0016			
UNI 1	M3 - M14 (Nr.4 - 9/16)	WE 01	$\varnothing 16$	36	39	49	5	8	2,1	A170E0116	A190E0132 A190E0140 A190E0150	A460E0125	A490E0150
			$\varnothing 20$	36	39	51	5	8	2,1	A170E0120			
			$\varnothing 25$	36	39	57	5	8	2,1	A170E0125			
			HSK-A32	40	62	57	5	7,5	2,5				
			HSK-A40	36	71	16	5	8	2,1				
			HSK-A40	36	73	20	5	8	2,1				
			HSK-A50	36	77	25	5	8	2,1				
			HSK-A50	40	91	25	5	7,5	2,5				
			HSK-A63	36	79	32	5	8	2,1				
			HSK-A63	40	93	32	5	7,5	2,5				
UNI 3	M4,5 - M24 (Nr.10 - 1")	WE 03	HSK-A80	36	83,5	40	5	8	2,1	A190E0180	A190E0340 A190E0350	A460E0325	A490E0350
			HSK-A100	36	85,5	50	5	8	2,1	A190E0100			
			HSK-A100	40	98	50	5	7,5	2,5	A490E0100			
			$\varnothing 25$	53	63	57	8,5	15	2,8	A170E0325			
			$\varnothing 25$	56	98	57	7	10	3				
			$\varnothing 32$	53	63	61	8,5	15	2,8	A170E0332			
			HSK-A40	53	107	20	8,5	15	2,8				
			HSK-A50	53	111	25	8,5	15	2,8				
			HSK-A50	56	140	25	7	10	3				
			HSK-A63	53	113	32	8,5	15	2,8	A190E0363			
UNI 4	M14 - M36 (9/16 - 1 3/8)	WE 04	HSK-A63	56	130	32	7	10	3	A190E0380	A190E0300	A460E0432	A490E0380
			HSK-A80	53	117,5	40	8,5	15	2,8				
			HSK-A80	56	133	40	7	10	3				
			HSK-A100	53	119,5	50	8,5	15	2,8				
			HSK-A100	56	135	50	7	10	3				
			HSK-A100	78	124	61	15	23,5	4,1	A170E0432			
UNI 5	M22 - M48 (7/8 - 1 3/4)	WE 05	$\varnothing 32$	80	147	61	15	20	5	A190E0463	A190E0500	A490E0300	A490E0300
			HSK-A63	164	32	15	23,5	4,1	A190E0400				
			HSK-A100	78	170,5	50							
			40	96	135,5	71	16,5	25	5,7	A170E0540			



Schnellwechsel-Einsätze siehe Seite 122- 137
 Quick-change adapters, see page 122- 137
 Adaptateurs à changement rapide, voir page 122- 137
 Bussole a cambio rapido, vedi pagina 122- 137

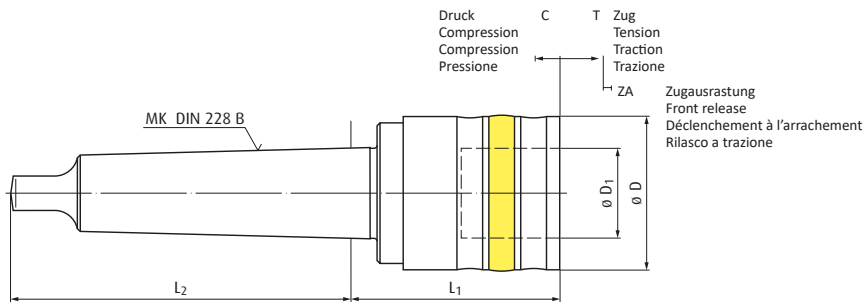
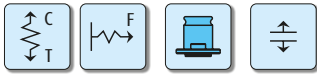

DIN 228 B

Typ Type Tipo		$\varnothing D_1$		C	T	$\varnothing D$	MK	L_1	L_2	ZA	
UNI 0	M1 - M10 (Nr.0 - 3/4)	13	WE 00	5	7,5	26	MK 1	43,5	62	1,7	A110.E0001
		13		5	7,5	26	MK 2	45	75	1,7	A110.E0002
UNI 1	M3 - M14 (Nr.4 - 9/16)	19	WE 01	5	8	36	MK 2	47	75	2,1	A110.E0102
		19		5	8	36	MK 3	47	94	2,1	A110.E0103
UNI 3	M4,5 - M24 (Nr.10 - 1")	31	WE 03	8,5	15	53	MK 3	71	4	2,8	A110.E0303
		31		8,5	15	53	MK 4	72	117,5	2,8	A110.E0304
		31		8,5	15	53	MK 5	72,5	149,5	2,8	A110.E0305
UNI 4	M14 - M36 (9/16 - 1 3/8)	48	WE 04	15	23,5	78	MK 4	105	117,5	4,1	A110.E0404
		48		15	23,5	78	MK 5	105,5	149,5	4,1	A110.E0405
UNI 5	M22 - M48 (7/8 - 1 3/4)	60	WE 05	16,5	25	96	MK 5	116,5	149,5	5,7	A110.E0505
		60		16,5	25	96	MK 6	118,5	210	5,7	A110.E0506



Schnellwechsel-Einsätze siehe Seite 122- 137
 Quick-change adapters, see page 122- 137
 Adaptateurs à changement rapide, voir page 122- 137
 Bussole a cambio rapido, vedi pagina 122- 137

UNI-HP-ER

NORIS
UNI-HP-ER

mKB

p_{max}
50bar
(700psi)



Druck
Compression
Compression
Pressione

C T Zug
Tension
Traction
Trazione

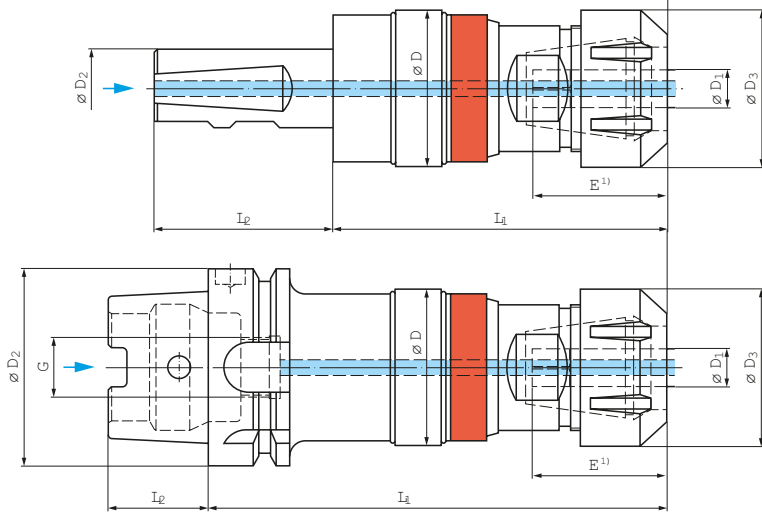

DIN 1835 B+E



DIN 69893 A

Typ Type Tipo		$\varnothing D_1$			C	T	$\varnothing D$	$\varnothing D_3$	$\varnothing D_2$	G	L_1	L_2		
UNI 1-HP-ER	M4 - M12 (Nr.8 - 7/16)	4,5 - 10	ER 20 GB	HI-Q/ ERMC 20	5	7,5	38	28	$\varnothing 25$	-	85	57	AK70.Z2025	
UNI 3-HP-ER	M4 - M20 (Nr.8 - 3/4)	4,5 - 16	ER 32 GB	HI-Q/ERC 32	7	10	52	50	$\varnothing 25$	-	115	57	AK70.Z3225	
UNI 1-HP-ER	M4 - M12 (Nr.8 - 7/16)	4,5 - 10	ER 20 GB	HI-Q/ ERMC 20	5	7,5	38	28	HSK-A50	M16 x 1	114	25		AK90.Z2050
					5	7,5	38	28	HSK-A63	M18 x 1	116	32		AK90.Z2063
					5	7,5	38	28	HSK-A100	M24 x 1,5	121	50		AK90.Z2000
UNI 3-HP-ER	M4 - M20 (Nr.8 - 3/4)	4,5 - 16	ER 32 GB	HI-Q/ERC 32	7	10	52	50	HSK-A63	M18 x 1	147	32		AK90.Z3263
					7	10	52	50	HSK-A100	M24 x 1,5	152	50		AK90.Z3200



Spannzangen und Dichtscheiben siehe Seite 120-121
Collets and sealing disks, see page 120-121
Pinces et disques d'étanchéité, voir page 120-121
Pinze di serraggio e guarnizioni, vedi pagina 120-121

ER | ER-GB

mKB
 p_{max}
100bar
 (1400psi)

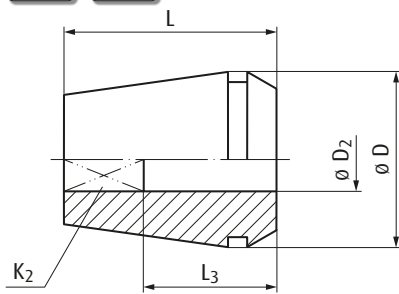

ER...
 ohne Vierkantmitnahme
 without square drive
 sans carré d'entraînement
 senza presa per il quadro

ER... GB
 mit Vierkantmitnahme
 with square drive
 avec carré d'entraînement
 con presa per il quadro



Typ · Type · Type · Tipo

	ER 8	ER 11 GB	ER 16 GB	ER 20 GB
			DS/ER 16	DS/ER 20
ø D	8	11	16	20
L	13,6	18	27,5	31,5

DIN											Artikel-Nr. Article no. Code article Articolo nr.		Artikel-Nr. Article no. Code article Articolo nr.		Artikel-Nr. Article no. Code article Articolo nr.		Artikel-Nr. Article no. Code article Articolo nr.	
ø D ₂	K ₂	M/MF	G	UN	M/MF	G	UN	L ₃	L ₃	L ₃	L ₃	L ₃	L ₃	L ₃	L ₃	L ₃	L ₃	L ₃
2,5	2,1	M1 -M1,8		Nr. 0	M3,5			ER/ER-GB DS/ER	-	AC408.Z0825								
2,8	2,1	M2 -M2,6		Nr. 1 Nr. 2	M4			ER/ER-GB DS/ER	-	AC408.Z0830	12	AD411.Z1120						
3,5	2,7	M3		Nr. 4 Nr. 5	M4,5 M5			ER/ER-GB DS/ER	-	AC408.Z0835	14	AD411.Z1130						
4	3	M3,5		Nr. 6	M5,5			ER/ER-GB DS/ER	-	AC408.Z0840	14	AD411.Z1140						
4,5	3,4	M4		Nr. 8	M6		1/4	ER/ER-GB DS/ER	-	AC408.Z0845	14	AD411.Z1145	15	AD416.Z1640 AK720.Z1645	15	AD420.Z2045 AK720.Z2045		
6	4,9	M4,5 -M6		Nr. 10	M8	1/16	5/16	ER/ER-GB DS/ER			14	AD411.Z1160	18	AD416Z1660 AK720.Z1660	18	AD420.Z2060 AK720.Z2060		
7	5,5	M7		1/4	M9 M10	1/8	3/8	ER/ER-GB DS/ER					18	AD416Z1670 AK720.Z1670	18	AD420.Z2070 AK720.Z2070		
8	6,2	M8		5/16	M11		7/16	ER/ER-GB DS/ER					22	AD416Z1680 AK720.Z1680	22	AD420.Z2080 AK720.Z2080		
9	7	M9			M12		1/2	ER/ER-GB DS/ER					22	AD416Z1690 AK720.Z1690	22	AD420.Z2090 AK720.Z2090		
10	8	M10	1/8	1/8				ER/ER-GB DS/ER									25	AD420.Z2010 AK720.Z20A0
11	9				M14	1/4	9/16	ER/ER-GB DS/ER										
12	9				M16	3/8	5/8	ER/ER-GB DS/ER										
14	11		1/4		M18		3/4	ER/ER-GB DS/ER										
16	12				M20	1/2		ER/ER-GB DS/ER										
18	14,5				M22 M24	5/8	7/8 1"	ER/ER-GB DS/ER										
20	16				M27	3/4		ER/ER-GB DS/ER										
22	18				M30	7/8	1 1/8 1 1/4	ER/ER-GB DS/ER										
25	20				M33	1"		ER/ER-GB DS/ER										
28	22				M36	1 1/8	1 3/8 1 1/2	ER/ER-GB DS/ER										
32	24				M39- M42	1 1/4		ER/ER-GB DS/ER										

DICHTSCHEIBEN DS | SEALING DISKS DISQUES D'ÉTANCHÉITÉ | GUARNIZIONI

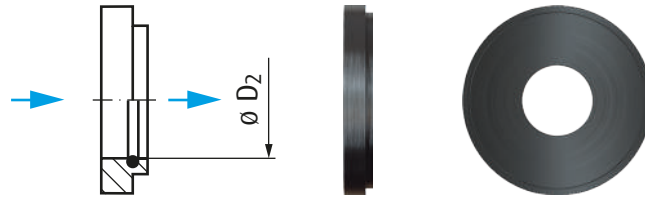

ER 25 GB		ER 32 GB		ER 40 GB		ER 50 GB				Typ · Type · Type · Tipo							
DS/ER 25		DS/ER 32		DS/ER 40		DS/ER 50											
25		32		40		51		ø D									
34		40		46		60		L									
L ₃	Artikel-Nr. Article no. Code article Articolo nr.	L ₃	Artikel-Nr. Article no. Code article Articolo nr.	L ₃	Artikel-Nr. Article no. Code article Articolo nr.	L ₃	Artikel-Nr. Article no. Code article Articolo nr.		UN	G	M/MF	UN	G	M/MF	ø D ₂	K ₂	DIN
								ER/ER-GB			M3,5	Nr. 0		M1-M1,8	2,5	2,1	
								DS/ER									
								ER/ER-GB			M4	Nr. 1 Nr. 2		M2-M2,6	2,8	2,1	
								DS/ER									
								ER/ER-GB			M4,5 M5	Nr. 4 Nr. 5		M3	3,5	2,7	
								DS/ER									
								ER/ER-GB			M5,5	Nr. 6		M3,5	4	3	
								DS/ER									
15	AD425Z2545 AK7Z0.Z2545	15	AD432.Z3245					ER/ER-GB	1/4		M6	Nr. 8		M4	4,5	3,4	
								DS/ER									
18	AD425Z2560 AK7Z0.Z2560	18	AD432.Z3260 AK7Z0.Z3260		AK7Z0Z4060			ER/ER-GB	5/16	1/16	M8	Nr. 10		M4,5-M6	6	4,9	
								DS/ER									
18	AD425Z2570 AK7Z0.Z2570	18	AD432.Z3270 AK7Z0.Z3270	18	AD440.Z4070 AK7Z0.Z4070			ER/ER-GB	3/8	1/8	M9 M10	1/4		M7	7	5,5	
								DS/ER									
22	AD425Z2580 AK7Z0.Z2580	22	AD432.Z3280 AK7Z0.Z3280	22	AD440.Z4080 AK7Z0.Z4080			ER/ER-GB	7/16		M11	5/16		M8	8	6,2	
								DS/ER									
22	AD425Z2590 AK7Z0.Z2590	22	AD432.Z3290 AK7Z0.Z3290	22	AD440.Z4090 AK7Z0.Z4090			ER/ER-GB	1/2		M12			M9	9	7	
								DS/ER									
25	AD425Z25A0 AK7Z0.Z25A0	25	AD432.Z32A0 AK7Z0.Z32A0	25	AD440.Z40A0 AK7Z0.Z40A0			ER/ER-GB				1/8	1/8	M10	10	8	
								DS/ER									
25	AD425Z25B0 AK7Z0.Z25B0	25	AD432.Z32B0 AK7Z0.Z32B0	25	AD440.Z40B1 AK7Z0.Z40B0			ER/ER-GB	9/16	1/4	M14				11	9	
								DS/ER									
25	AD425Z25C0 AK7Z0.Z25C0	25	AD432.Z32C0 AK7Z0.Z32C0	25	AD440.Z40C2 AK7Z0.Z40C0			ER/ER-GB	5/8	3/8	M16				12	9	
								DS/ER									
25	AD425Z25D0 AK7Z0.Z25E0	25	AD432.Z32E0 AK7Z0.Z32E0	25	AD440.Z40E4 AK7Z0.Z40E0			ER/ER-GB	3/4		M18		1/4		14	11	
								DS/ER									
25	AD425Z25E0 AK7Z0.Z25G0	25	AD432.Z32G0 AK7Z0.Z32G0	25	AD440.Z40G6 AK7Z0.Z40G0			ER/ER-GB		1/2	M20				16	12	
								DS/ER									
								ER/ER-GB	7/8 1"	5/8	M22 M24				18	14,5	
								DS/ER									
								ER/ER-GB		3/4	M27				20	16	
								DS/ER									
								ER/ER-GB	1 1/8 1 1/4	7/8	M30				22	18	
								DS/ER									
								ER/ER-GB		1"	M33				25	20	
								DS/ER									
								ER/ER-GB	1 3/8 1 1/2	1 1/8	M36				28	22	
								DS/ER									
								ER/ER-GB		1 1/4	M39- M42				32	24	
								DS/ER									



mKB¹⁾

p_{max}
50bar
(700psi)

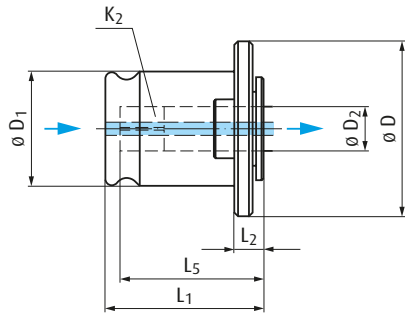

SCHNELLWECHSEL-EINSÄTZE
QUICK-CHANGE ADAPTERS
ADAPTATEURS À CHANGEMENT RAPIDE
BUSSOLE A CAMBIO RAPIDO

	M1 - M10		M3 - M14		M4,5 - M24		M14 - M36		M22 - M48		
Ø D	23		30		48		70		92		
Ø D ₁	13		19		31		48		60		
L ₁	27		29		45		67		111		
L ₂	7		7		10		11		48		
DIN	WE 00 - DIN		WE 01 - DIN		WE 03 - DIN		WE 04 - DIN		WE 05 - DIN		
Ø D ₂ K ₂	L ₅		L ₅		L ₅		L ₅		L ₅		
2,5 2,1	M1 - M1,8	M3,5	20	A1100.E0000							
2,8 2,1	M2 - M2,6	M4	20	A1100.E0001							
3,5 2,7	M3	M4,5 - M5	21	A1100.E0002	23	A1101.E0102					
4 3	M3,5	M5,5	21	A1100.E0003	23	A1101.E0103					
4,5 3,4	M4	M6	21	A1100.E0004	23	A1101.E0104					
6 4,9	M4,5 - M6	M8	23	A1100.E0006	25	A1101.E0106	37	A1103.E0306			
7 5,5	M7	M9 - M10	23	A1100.E0007	25	A1101.E0107	37	A1103.E0307			
8 6,2	M8	M11	21	A1100.E0008 2)	26	A1101.E0108	38	A1103.E0308			
9 7	M9	M12			27	A1101.E0109	39	A1103.E0309			
10 8	M10				27	A1101.E0110	40	A1103.E0310			
11 9		M14			27	A1101.E0111	41	A1103.E0311	53	A1104.E0411	
12 9		M16			25	A1101.E0112 2)	41	A1103.E0312	53	A1104.E0412	
14 11		M18					43	A1103.E0313	55	A1104.E0413	
16 12		M20					44	A1103.E0314	56	A1104.E0414	
18 14,5		M22 - M24					44	A1103.E0315	58	A1104.E0415	
20 16		M27					39	A1103.E0316 2)	60	A1104.E0416	
22 18		M30					39	A1103.E0317 2)	62	A1104.E0417	
25 20		M33							64	A1104.E0418	
28 22		M36							66	A1104.E0419	
32 24		M39 - M42							61	A1104.E0420 2)	
36 29		M45 - M48							60	A1104.E0421 2)	
40 32		M52 - M56								83	A1105.E0522 2)
45 35		M68								83	A1105.E0523 2)

¹⁾ Bei Verwendung von Gewindebohrern / Gewindeformern mit innerer Kühlschmierstoff-Zufuhr
If used with taps / cold-forming taps with internal coolant-lubricant supply
Pour l'utilisation des tarauds coupants ou à refouler avec lubrification par le centre
Per l'utilizzazione di maschi / maschi a rullare con lubrorefrigerazione interna

²⁾ Schnellwechsel-Einsätze mit erweitertem Spannbereich Typ WE-E
Quick-change adapters with extended clamping range type WE-E
Adaptateurs à changement rapide avec gamme de serrage étendue type WE-E
Bussole a cambio rapido con campo di serraggio aumentato tipo WE-E

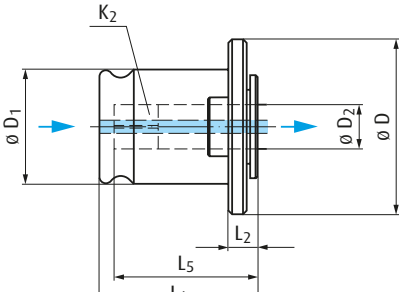

SCHNELLWECHSEL-EINSÄTZE
QUICK-CHANGE ADAPTERS
ADAPTATEURS À CHANGEMENT RAPIDE
BUSSOLE A CAMBIO RAPIDO

		M1 - M10	M3 - M14	M4,5 - M24	M14 - M36	M22 - M48
	∅ D	23	30	48	70	92
	∅ D ₁	13	19	31	48	60
	L ₁	27	29	45	67	111
	L ₂	7	7	10	11	48
ISO		WE 00 - DIN	WE 01 - DIN	WE 03 - DIN	WE 04 - DIN	WE 05 - DIN
∅ D ₂	K ₂	L ₅	L ₅	L ₅	L ₅	L ₅
2,24	1,8	M3	19	A1200.E0000		
2,5	2	M1 - M2	19	A1200.E0001		
2,8	2,24	M2,2 - M2,5	20	A1200.E0002		
3,15	2,5	M3	20	A1200.E0003		
3,55	2,8	M3,5	20	A1200.E0004	22	A1201.E0104
4	3,15	M4	21	A1200.E0005	23	A1201.E0105
4,5	3,55	M4,5	21	A1200.E0006	23	A1201.E0106
5	4	M5	22	A1200.E0007	24	A1201.E0107
5,6	4,5	M7	22	A1200.E0008	24	A1201.E0108
6,3	5	M6	23	A1200.E0009	25	A1201.E0109
7,1	5,6	M7	23	A1200.E0010	25	A1201.E0110
8	6,3	M8	21	A1200.E0011 2)	26	A1201.E0111
9	7,1	M9	27	A1201.E0112	38	A1203.E0311
10	8	M10	27	A1101.E0110	39	A1203.E0312
11,2	9	M14	27	A1201.E0114	40	A1103.E0310
12,5	10	M16	25	A1201.E0115 2)	41	A1203.E0314
14	11,2	M18 - M20	42	A1203.E0315	53	A1204.E0414
16	12,5	M22	43	A1203.E0316	54	A1204.E0415
18	14	M24	43	A1203.E0317	55	A1204.E0416
20	16	M27 - M30	43	A1203.E0318	57	A1204.E0417
22,4	18	M33	40	A1103.E0316 2)	59	A1204.E0418
25	20	M36	39	A1203.E0320 2)	61	A1104.E0416
28	22,4	M39 - M42			61	A1104.E0418
31,5	25	M45 - M48			63	A1204.E0420
35,5	28	M52 - M56			65	A1104.E0418
40	31,5	M60 - M64			66	A1204.E0422
45	35,5	M68			61	A1204.E0424 2)
					81	A1205.E0524 2)
					82	A1205.E0525 2)
					83	A1205.E0526 2)

¹⁾ Bei Verwendung von Gewindebohrern / Gewindefornern mit innerer Kühlschmierstoff-Zufuhr
If used with taps / cold-forming taps with internal coolant-lubricant supply
Pour l'utilisation des tarauds coupants ou à refouler avec lubrification par le centre
Per l'utilizzazione di maschi / maschi a rullare con lubrorefrigerazione interna

²⁾ Schnellwechsel-Einsätze mit erweitertem Spannbereich Typ WE-E
Quick-change adapters with extended clamping range type WE-E
Adaptateurs à changement rapide avec gamme de serrage étendue type WE-E
Bussole a cambio rapido con campo di serraggio aumentato tipo WE-E



mKB¹⁾

p_{max}
50bar
(700psi)

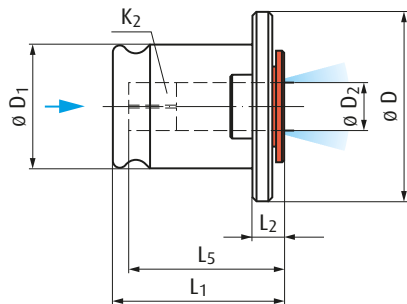

FÜR GEWINDEBOHRER / GEWINDEFORMER OHNE INNERE KÜHLSCHMIERSTOFF-ZUFUHR
FOR TAPS / COLD-FORMING TAPS WITHOUT INTERNAL COOLANT-LUBRICANT SUPPLY
POUR TARAUDS COUPANTS OU À REFOULER SANS LUBRIFICATION PAR LE CENTRE
PER MASCHI / MASCHI A RULLARE SENZA LUBROREFRIGERAZIONE INTERNA

	M3 - M14	M4,5 - M24	M14 - M36	M22 - M48
ø D	30	48	70	92
ø D ₁	19	31	48	60
L ₁	29	45	67	111
L ₂	7	10	11	48

DIN		WE 01 - DIN		WE 03 - DIN		WE 04 - DIN		WE 05 - DIN	
ø D ₂	K ₂	L ₅		L ₅		L ₅		L ₅	
2,5	2,1	M1 - M1,8	M3,5						
2,8	2,1	M2 - M2,6	M4						
3,5	2,7	M3	M4,5 - M5	21	A2101.E0102				
4	3	M3,5	M5,5	23	A2101.E0103				
4,5	3,4	M4	M6	23	A2101.E0104				
6	4,9	M4,5 - M6	M8	25	A2101.E0106	37	A2103.E0306		
7	5,5	M7	M9 - M10	25	A2101.E0107	37	A2103.E0307		
8	6,2	M8	M11	26	A2101.E0108	38	A2103.E0308		
9	7	M9	M12	27	A2101.E0109	39	A2103.E0309		
10	8	M10		27	A2101.E0110	40	A2103.E0310		
11	9		M14	27	A2101.E0111	41	A2103.E0311	53	A2104.E0411
12	9		M16			41	A2103.E0312	53	A2104.E0412
14	11		M18			43	A2103.E0313	55	A2104.E0413
16	12		M20			44	A2103.E0314	56	A2104.E0414
18	14,5		M22 - M24			44	A2103.E0315	58	A2104.E0415
20	16		M27					60	A2104.E0416
22	18		M30					62	A2104.E0417
25	20		M33					64	A2104.E0418
28	22		M36					66	A2104.E0419
32	24		M39 - M42						
36	29		M45 - M48						

¹⁾ Entlang des Werkzeugschafts
Along the tool shank
Le long de la queue d'outil
Lungo il gambo dell'utensile



o\ Oy u@ Vo V \ k@ k - @J -) -

Das REIME Team steht Ihnen bei der Lösung Ihrer Zerspanungsaufgabe gerne zur Seite

The REIME team will be happy to solve your threading tasks

0 k-@-

@ k-@-

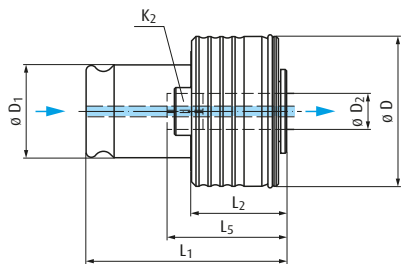
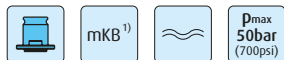

MIT ÜBERLASTKUPPLUNG
WITH OVERLOAD CLUTCH
AVEC ACCOUPLEMENT DÉBRAYABLE
CON FRIZIONE

	M1 - M10		M3 - M14		M4,5 - M24		M14 - M36		M22 - M48		
ϕD	24		33		50		72		95		
ϕD_1	13		19		31		48		60		
L_1	41,5		47		69		101		138		
L_2	22		25		34		45		75		
DIN		WE 00 - DIN		WE 01 - DIN		WE 03 - DIN		WE 04 - DIN		WE 05 - DIN	
ϕD_2	K_2		L_5		L_5		L_5		L_5		
2,5	2,1	M1 - M1,8	21	A4100.E0001							
2,5	2,1	M3,5	21	A4100.E0002							
2,8	2,1	M2	21	A4100.E0011							
2,8	2,1	M2,5	21	A4100.E0012							
2,8	2,1	M4	21	A4100.E0013							
3,5	2,7	M3	22	A4100.E0021	23	A4101.E0121					
3,5	2,7	M4,5 - M5	22	A4100.E0022	23	A4101.E0122					
4	3	M3,5	22	A4100.E0030	23	A4101.E0130					
4,5	3,4	M4	22	A4100.E0041	23	A4101.E0141					
4,5	3,4	M6	22	A4100.E0042	23	A4101.E0142					
6	4,9	M4,5 - M5	24	A4100.E0061	25	A4101.E0161	38	A4103.E0361			
6	4,9	M6	24	A4100.E0062	25	A4101.E0162	38	A4103.E0362			
6	4,9	M8	24	A4100.E0063	25	A4101.E0163	38	A4103.E0363			
7	5,5	M10	24	A4100.E0070	25	A4101.E0170	38	A4103.E0370			
8	6,2	M8		2)	26	A4101.E0180	39	A4103.E0380			
9	7	M12			27	A4101.E0190	40	A4103.E0390			
10	8	M10			28	A4101.E01A0	41	A4103.E03A0			
11	9	M14			29	A4101.E01A1	42	A4103.E03A1	56	A4104.E04A1	
12	9	M16				2)	42	A4103.E03A2	56	A4104.E04A2	
14	11	M18					44	A4103.E03A3	58	A4104.E04A3	
16	12	M20					45	A4103.E03A4	59	A4104.E04A4	
18	14,5	M22 - M24					47	A4103.E03A5	61	A4104.E04A5	94
20	16	M27						2)	63	A4104.E04A6	96
22	18	M30						2)	65	A4104.E04A7	98
25	20	M33							67	A4104.E04A8	100
28	22	M36							69	A4104.E04A9	102
32	24	M39 - M42								2)	104
36	29	M45 - M48								2)	109
40	32	M52 - M56									2)
45	35	M60									2)

1) " † 8 8 M -
If used with taps / cold-forming taps with internal coolant-lubricant supply
h
h

2) Schnellwechsel-Einsätze mit erweitertem Spannbereich Typ WE-U-E siehe Seite 128
Quick-change adapters with extended clamping range type WE-U-E, see page 128
Adaptateurs à changement rapide avec gamme de serrage étendue type WE-U-E, voir page 128
† - y -

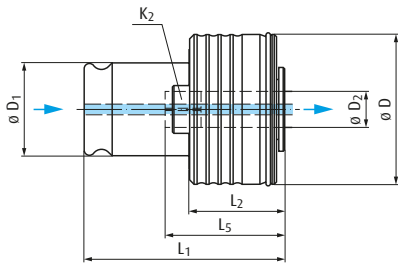
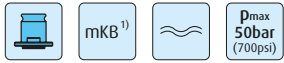

MIT ÜBERLASTKUPPLUNG
WITH OVERLOAD CLUTCH
AVEC ACCOUPLEMENT DÉBRAYABLE
CON FRIZIONE

		M1 - M10	M3 - M14	M4,5 - M24	M14 - M36	M22 - M48
$\varnothing D$		24	33	50	72	95
$\varnothing D_1$		13	19	31	48	60
L_1		41,5	47	69	101	138
L_2		22	25	34	45	75
ISO		WE 00 - ISO	WE 01 - ISO	WE 03 - ISO	WE 04 - ISO	WE 05 - ISO
$\varnothing D_2$	K_2	L_5	L_5	L_5	L_5	L_5
2,8	2,24	M2,2 - M2,5	21	A4200.E0020		
3,15	2,5	M3	21	A4200.E0031		
3,15	2,5	M4	21	A4200.E0032		
3,55	2,8	M3,5	21	A4200.E0041	22	A4201.E0141
3,55	2,8	M4,5	21	A4200.E0042	22	A4201.E0142
4	3,15	M4	22	A4200.E0051	23	A4201.E0151
4	3,15	M5	22	A4200.E0052	23	A4201.E0152
4,5	3,55	M4,5	22	A4200.E0061	23	A4201.E0161
4,5	3,55	M6	22	A4200.E0062	23	A4201.E0162
5	4	M5	23	A4200.E0070	24	A4201.E0170
5,6	4,5	M7	23	A4200.E0080	24	A4201.E0180
6,3	5	M6	24	A4200.E0091	25	A4201.E0191
6,3	5	M8	24	A4200.E0092	25	A4201.E0192
7,1	5,6	M7	24	A4200.E00A0	25	A4201.E01A0
8	6,3	M8	29	A4201.E01A1	39	A4203.E03A1
9	7,1	M9	27	A4201.E01A2	40	A4203.E03A2
10	8	M10	28	A4101.E01A0	41	A4103.E03A0
11,2	9	M14	29	A4201.E01A4	42	A4203.E03A4
12,5	10	M16		2)	43	A4203.E03A5
14	11,2	M18 - M20			44	A4203.E03A6
16	12,5	M22			46	A4203.E03A7
18	14	M24			48	A4203.E03A8
20	16	M27 - M30			62	A4204.E04A8
22,4	18	M33			64	A4104.E04A6
25	20	M36			66	A4204.E04B0
28	22,4	M39 - M42			68	A4104.E04A8
31,5	25	M45 - M48			70	A4204.E04B2
35,5	28	M52 - M56				2)
40	31,5	M60 - M64				2)
45	35,5	M68				2)

1) " † 8 8 M -
If used with taps / cold-forming taps with internal coolant-lubricant supply
h
h

2) Schnellwechsel-Einsätze mit erweitertem Spannbereich Typ WE-U-E siehe Seite 128
Quick-change adapters with extended clamping range type WE-U-E, see page 128
Adaptateurs à changement rapide avec gamme de serrage étendue type WE-U-E, voir page 128
† - y -

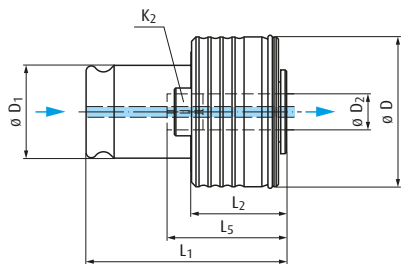
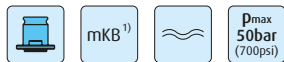

MIT ÜBERLASTKUPPLUNG UND ERWEITERTEM SPANNBEREICH
WITH OVERLOAD CLUTCH AND EXTENDED CLAMPING RANGE
AVEC ACCOUPLEMENT DÉBRAYABLE ET GAMME DE SERRAGE ÉTENDUE
CON FRIZIONE DI SOVRACCARICO E CAMPO DI SERRAGGIO ESTESO

	M8 - M11		M16		M27 - M30		M39 - M48		M52 - M60				
$\varnothing D$	24		33		50		72		95				
$\varnothing D_1$	3		19		31		48		60				
L_1	8,5		44		64,5		96		125				
L_2	19		22,5		29,5		40,5		62				
DIN			WE 00-U-E/DIN		WE 01-U-E/DIN		WE 03-U-E/DIN		WE 04-U-E/DIN		WE 05-U-E/DIN		
$\varnothing D_2$	K_2		L_5		L_5		L_5		L_5		L_5		
8	6,2	M8	M11	28	A4100.E0080								
12	9		M16			37	A4101.E01A2						
20	16		M27					50	A4103.E03A6				
22	18		M30					52	A4103.E03A7				
32	24		M39 - M42							66	A4104.E04B0		
36	29		M45 - M48							71	A4104.E04B1	91	A4105.E05B2
40	32		M52 - M56									94	A4105.E05B3
45	35		M60										
ISO			WE 00-U-E/ISO		WE 01-U-E/ISO		WE 03-U-E/ISO		WE 04-U-E/ISO		WE 05-U-E/ISO		
$\varnothing D_2$	K_2		L_5		L_5		L_5		L_5		L_5		
8	6,3	M8	M10 -M11	28	A4200.E00A1								
12,5	10		M16			38	A4201.E01A5						
20	16		M27 - M30					51	A4103.E03A6				
22,4	18		M33					53	A4203.E03B0				
31,5	25		M45 - M48							69	A4204.E04B3		
35,5	28		M52 - M56							72	A4204.E04B4		
40	31,5		M60 - M64									96	A4205.E05B4
45	35,5		M68									103	A4205.E05B5

¹⁾ Bei Verwendung von Gewindebohrern / Gewindeformern mit innerer Kühlschmierstoff-Zufuhr
If used with taps / cold-forming taps with internal coolant-lubricant supply
Pour l'utilisation des tarauds coupants ou à refouler avec lubrification par le centre
Per l'utilizzazione di maschi / maschi a rullare con lubrorefrigerazione interna

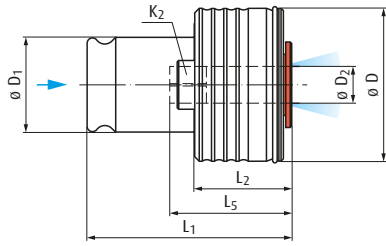
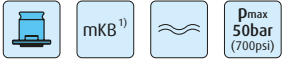

FÜR GEWINDEBOHRER / GEWINDEFORMER OHNE INNERE KÜHLSCHMIERSTOFF-ZUFUHR
FOR TAPS / COLD-FORMING TAPS WITHOUT INTERNAL COOLANT-LUBRICANT SUPPLY
POUR TARAUDS COUPANTS OU À REFOULER SANS LUBRIFICATION PAR LE CENTRE
PER MASCHI / MASCHI A RULLARE SENZA LUBROREFRIGERAZIONE INTERNA

		M3 - M14		M4,5 - M24		M14 - M36		M22 - M48	
$\varnothing D$		33		50		72		95	
$\varnothing D_1$		19		31		48		60	
L_1		47		69		101		138	
L_2		25		34		45		75	
DIN		WE 01 - DIN		WE 03 - DIN		WE 04 - DIN		WE 05 - DIN	
$\varnothing D_2$	K_2	L_5		L_5		L_5		L_5	
3,5	2,7	M3	22	A5101.E0121					
3,5	2,7	M4,5 - M5	22	A5101.E0122					
4	3	M3,5	22	A5101.E0135					
4,5	3,4	M4	23	A5101.E0141					
4,5	3,4	M6	23	A5101.E0142					
6	4,9	M4,5 - M5	25	A5101.E0161	38	A5103.E0361			
6	4,9	M6	25	A5101.E0162	38	A5103.E0362			
6	4,9	M8	25	A5101.E0163	38	A5103.E0363			
7	5,5	M10	25	A5101.E0175	38	A5103.E0375			
8	6,2	M8	26	A5101.E0185	39	A5103.E0385			
9	7	M12	27	A5101.E0195	40	A5103.E0395			
10	8	M10	28	A5101.E01A5	41	A5103.E03A5			
11	9	M14	29	A5101.E01B5	42	A5103.E03B5	56	A5104.E04B5	
12	9	M16			42	A5103.E03C5	56	A5104.E04C5	
14	11	M18			44	A5103.E03D5	58	A5104.E04D5	
16	12	M20			45	A5103.E03E5	59	A5104.E04E5	
18	14,5	M22 - M24			47	A5103.E03F5	61	A5104.E04F5	94
20	16	M27					63	A5104.E04G5	96
22	18	M30					65	A5104.E04H5	98
25	20	M33					67	A5104.E04J5	100
28	22	M36					69	A5104.E04K5	102
32	24	M39 - M42							104
36	29	M45 - M48							109
									A5105.E05F5
									A5105.E05G5
									A5105.E05H5
									A5105.E05J5
									A5105.E05K5
									A5105.E05L5
									A5105.E05M5

¹⁾ Entlang des Werkzeugschafts
Along the tool shank
Le long de la queue d'outil
Lungo il gambo dell'utensile

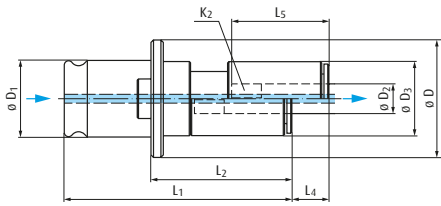

MIT LÄNGENNACHSTELLUNG, OHNE ÜBERLASTKUPPLUNG
WITH LENGTH ADJUSTMENT, WITHOUT OVERLOAD CLUTCH
AVEC RÉGLAGE DE LONGUEUR, SANS ACCOUPLEMENT DÉBRAYABLE
CON REGOLAZIONE DELLA LUNGHEZZA, SENZA FRIZIONE

		M1 - M10	M3 - M14	M4,5 - M24	M14 - M36	M22 - M48
$\varnothing D$		23	30	48	70	92
$\varnothing D_1$		13	19	31	48	60
$\varnothing D_3$		13	18	30	47	58
L_1		48	55	94	137	205
L_2		29	33	59	81	142
L_4		8	10	15	25	40

DIN		WE 00-L/DIN		WE 01-L/DIN		WE 03-L/DIN		WE 04-L/DIN		WE 05-L/DIN			
$\varnothing D_2$	K_2	L_5		L_5		L_5		L_5		L_5			
2,5	2,1	M1 - M1,8	M3,5	21	A6100.E0000								
2,8	2,1	M2 - M2,6	M4	21	A6100.E0001								
3,5	2,7	M3	M4,5 - M5	22	A6100.E0002	23	A6101.E0102						
4	3	M3,5	M5,5	22	A6100.E0003	22	A6101.E0103						
4,5	3,4	M4	M6	22	A6100.E0004	23	A6101.E0104						
6	4,9	M4,5 - M6	M8	24	A6100.E0006	25	A6101.E0106	38	A6103.E0306				
7	5,5	M7	M9 - M10	24	A6100.E0007	25	A6101.E0107	38	A6103.E0307				
8	6,2	M8	M11		2)	26	A6101.E0108	39	A6103.E0308				
9	7	M9	M12			27	A6101.E0109	40	A6103.E0309				
10	8	M10				28	A6101.E0110	41	A6103.E0310				
11	9		M14			29	A6101.E0111	42	A6103.E0311	55	A6104.E0411		
12	9		M16				2)	42	A6103.E0312	55	A6104.E0412		
14	11		M18					44	A6103.E0313	57	A6104.E0413		
16	12		M20					45	A6103.E0314	58	A6104.E0414		
18	14,5		M22 - M24					47	A6103.E0315	60	A6104.E0415	94	A6105.E0515
20	16		M27						2)	62	A6104.E0416	96	A6105.E0516
22	18		M30						2)	64	A6104.E0417	98	A6105.E0517
25	20		M33							66	A6104.E0418	100	A6105.E0518
28	22		M36							68	A6104.E0419	102	A6105.E0519
32	24		M39 - M42								2)	104	A6105.E0520
36	29		M45 - M48								2)	109	A6105.E0521
40	32		M52 - M56										2)
45	35		M60										2)

¹⁾ " † " 8 " 8 " M " -

If used with taps / cold-forming taps with internal coolant-lubricant supply

h

h

²⁾ Schnellwechsel-Einsätze mit erweitertem Spannbereich Typ WE-U-E siehe Seite 128

Quick-change adapters with extended clamping range type WE-U-E, see page 128

Adaptateurs à changement rapide avec gamme de serrage étendue type WE-U-E, voir page 128

† - y -

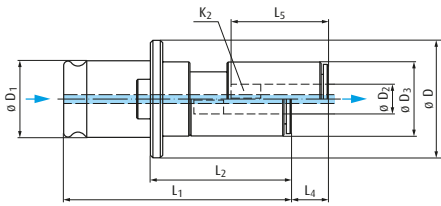
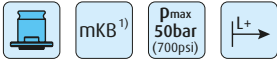

MIT LÄNGENNACHSTELLUNG, OHNE ÜBERLASTKUPPLUNG
WITH LENGTH ADJUSTMENT, WITHOUT OVERLOAD CLUTCH
AVEC RÉGLAGE DE LONGUEUR, SANS ACCOUPLEMENT DÉBRAYABLE
CON REGOLAZIONE DELLA LUNGHEZZA, SENZA FRIZIONE

		M1 - M9	M3,5 - M14	M6 - M24	M14 - M36	M24 - M48
$\varnothing D$		23	30	48	70	92
$\varnothing D_1$		13	19	31	48	60
$\varnothing D_3$		13	18	30	47	58
L_1		48	55	94	137	205
L_2		29	33	59	81	142
L_4		8	10	15	25	40

ISO		WE 00-L/ISO	WE 01-L/ISO	WE 03-L/ISO	WE 04-L/ISO	WE 05-L/ISO							
$\varnothing D_2$	K_2	L_5	L_5	L_5	L_5	L_5							
2,24	1,8	M3	20	A6200.E0000									
2,5	2	M1 - M2	M3,5	20	A6200.E0001								
2,8	2,24	M2,2 - M2,6		21	A6200.E0002								
3,15	2,5	M3	M4	21	A6200.E0003								
3,55	2,8	M3,5	M4,5	21	A6200.E0004	22	A6201.E0104						
4	3,15	M4	M5	22	A6200.E0005	23	A6201.E0105						
4,5	3,55	M4,5	M6	22	A6200.E0006	23	A6201.E0106						
5	4	M5		23	A6200.E0007	24	A6201.E0107						
5,6	4,5		M7	23	A6200.E0008	24	A6201.E0108						
6,3	5	M6	M8	24	A6200.E0009	25	A6201.E0109	38	A6203.E0309				
7,1	5,6	M7	M9	24	A6200.E0010	25	A6201.E0110	38	A6203.E0310				
8	6,3	M8	M10 - M11		2)	26	A6201.E0111	39	A6203.E0311				
9	7,1	M9	M12			27	A6201.E0112	40	A6203.E0312				
10	8	M10				28	A6101.E0110	41	A6103.E0310				
11,2	9		M14			29	A6201.E0114	42	A6203.E0314	55	A6204.E0414		
12,5	10		M16				2)	43	A6203.E0315	56	A6204.E0415		
14	11,2		M18 - M20					44	A6203.E0316	57	A6204.E0416		
16	12,5		M22					46	A6203.E0317	59	A6204.E0417		
18	14		M24					48	A6203.E0318	61	A6204.E0418	95	A6205.E0518
20	16		M27 - M30						2)	63	A6104.E0416	97	A6105.E0516
22,4	18		M33						2)	65	A6204.E0420	99	A6205.E0520
25	20		M36							67	A6104.E0418	101	A6105.E0518
28	22,4		M39 - M42							69	A6204.E0422	103	A6205.E0522
31,5	25		M45 - M48								2)	105	A6205.E0523
35,5	28		M52 - M56								2)		2)
40	31,5		M60 - M64										2)
45	35,5		M68										2)

¹⁾ " † 8 " 8 " M
If used with taps / cold-forming taps with internal coolant-lubricant supply
h
h

²⁾ Schnellwechsel-Einsätze mit erweitertem Spannbereich Typ WE-U-E siehe Seite 128
Quick-change adapters with extended clamping range type WE-U-E, see page 128
Adaptateurs à changement rapide avec gamme de serrage étendue type WE-U-E, voir page 128
" † - y "

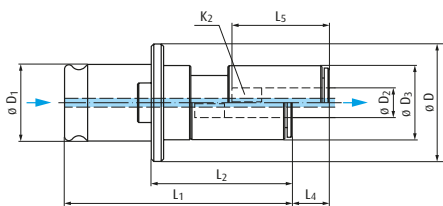
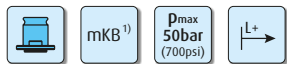

MIT LÄNGENNACHSTELLUNG, OHNE ÜBERLASTKUPPLUNG
WITH LENGTH ADJUSTMENT, WITHOUT OVERLOAD CLUTCH
AVEC RÉGLAGE DE LONGUEUR, SANS ACCOUPLEMENT DÉBRAYABLE
CON REGOLAZIONE DELLA LUNGHEZZA, SENZA FRIZIONE

	M8 - M11	M16	M27 - M30	M39 - M48	M52 - M60
$\varnothing D$	23	30	48	70	92
$\varnothing D_1$	13	19	31	48	60
$\varnothing D_3$	18	30	50	60	58
L_1	73	89	147	191	190
L_2	54	67	112	135	127
L_4	8	10	15	25	40

DIN		WE 00-L-E/DIN		WE 01-L-E/DIN		WE 03-L-E/DIN		WE 04-L-E/DIN		WE 05-L-E/DIN	
$\varnothing D_2$	K_2	L_5		L_5		L_5		L_5		L_5	
8	6,2	M8	M11	26	A6100.E0008						
12	9		M16			41	A6101.E0112				
20	16		M27								
22	18		M30			64	A6103.E0316				
						66	A6103.E0317				
32	24		M39 - M42					102	A6104.E0420		
36	29		M45 - M48					107	A6104.E0421	83	A6105.E0522
40	32		M52 - M56							83	A6105.E0523
45	35		M60								

	M8 - M11	M16	M27 - M33	M45 - M56	M52 - M68
$\varnothing D$	23	30	48	70	92
$\varnothing D_1$	13	19	31	48	60
$\varnothing D_3$	18	30	50	60	58
L_1	73	89	147	191	190
L_2	54	67	112	135	127
L_4	8	10	15	25	40

ISO		WE 00-L-E/ISO		WE 01-L-E/ISO		WE 03-L-E/ISO		WE 04-L-E/ISO		WE 05-L-E/ISO	
$\varnothing D_2$	K_2	L_5		L_5		L_5		L_5		L_5	
8	6,3	M8	M10 - M11	26	A6200.E0011						
12,5	10		M16			42	A6201.E0115				
20	16		M27 - M30								
22,4	18		M33			65	A6103.E0316				
						67	A6203.E0320				
31,5	25		M45 - M48					103	A6204.E0423		
35,5	28		M52 - M56					106	A6204.E0424	76	A6205.E0524
40	31,5		M60 - M64							79	A6205.E0525
45	35,5		M68							83	A6205.E0526

¹⁾ Bei Verwendung von Gewindebohrern / Gewindeformern mit innerer Kühlschmierstoff-Zufuhr
If used with taps / cold-forming taps with internal coolant-lubricant supply
Pour l'utilisation des tarauds coupants ou à refouler avec lubrification par le centre
Per l'utilizzazione di maschi / maschi a rullare con lubrorefrigerazione interna

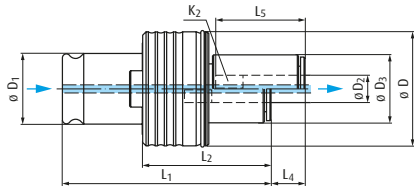

MIT LÄNGENNACHSTELLUNG, MIT ÜBERLASTKUPPLUNG
WITH LENGTH ADJUSTMENT, WITH OVERLOAD CLUTCH
AVEC RÉGLAGE DE LONGUEUR, AVEC ACCOUPLEMENT DÉBRAYABLE
CON REGOLAZIONE DELLA LUNGHEZZA, CON FRIZIONE

		M1 - M10	M3 - M14	M4,5 - M24	M14 - M36	M22 - M48
$\varnothing D$		24	33	50	72	95
$\varnothing D_1$		13	19	31	48	60
$\varnothing D_3$		13	18	30	47	58
L_1		49	55	94	137	205
L_2		29	33	59	81	142
L_4		8	10	15	25	40

DIN		WE 00-UL/DIN	WE 01-UL/DIN	WE 03-UL/DIN	WE 04-UL/DIN	WE 05-UL/DIN		
$\varnothing D_2$	K_2	L_3	L_3	L_3	L_3	L_3		
2,5	2,1	M1 - M1,8	21	A7100.E0001				
2,5	2,1	M3,5	21	A7100.E0002				
2,8	2,1	M2	21	A7100.E0011				
2,8	2,1	M2,5	21	A7100.E0012				
2,8	2,1	M4	21	A7100.E0013				
3,5	2,7	M3	22	A7100.E0021	23	A7101.E0121		
3,5	2,7	M4,5 - M5	22	A7100.E0022	23	A7101.E0122		
4	3	M3,5	22	A7100.E0036	22	A7101.E0136		
4,5	3,4	M4	22	A7100.E0041	23	A7101.E0141		
4,5	3,4	M6	22	A7100.E0042	23	A7101.E0142		
6	4,9	M4,5 - M5	24	A7100.E0061	25	A7101.E0161	38	A7103.E0361
6	4,9	M6	24	A7100.E0062	25	A7101.E0162	38	A7103.E0362
6	4,9	M8	24	A7100.E0063	25	A7101.E0163	38	A7103.E0363
7	5,5	M10	24	A7100.E0076	25	A7101.E0176	38	A7103.E0376
8	6,2	M8	26	A7101.E0186	39	A7103.E0386		
9	7	M12	27	A7101.E0196	40	A7103.E0396		
10	8	M10	28	A7101.E01A6	41	A7103.E03A6		
11	9	M14	29	A7101.E01B6	42	A7103.E03B6	55	A7104.E04B6
12	9	M16	42	A7103.E03C6	55	A7104.E04C6		
14	11	M18	44	A7103.E03D6	57	A7104.E04D6		
16	12	M20	45	A7103.E03E6	58	A7104.E04E6		
18	14,5	M22 - M24	47	A7103.E03F6	60	A7104.E04F6	94	A7105.E05F6
20	16	M27	62	A7104.E04G6	96	A7105.E05G6		
22	18	M30	64	A7104.E04H6	98	A7105.E05H6		
25	20	M33	66	A7104.E04J6	100	A7105.E05J6		
28	22	M36	68	A7104.E04K6	102	A7105.E05K6		
32	24	M39 - M42	104	A7105.E05L6				
36	29	M45 - M48	109	A7105.E05M6				
40	32	M60 - M64						2)
45	35	M68						2)

¹⁾ Bei Verwendung von Gewindebohrern / Gewindeformern mit innerer Kühlschmierstoff-Zufuhr
If used with taps / cold-forming taps with internal coolant-lubricant supply
Pour l'utilisation des tarauds coupants ou à refouler avec lubrification par le centre
Per l'utilizzazione di maschi / maschi a rullare con lubrorefrigerazione interna

²⁾ Schnellwechsel-Einsätze mit erweitertem Spannbereich Typ WE-UL-E siehe Seite 135
Quick-change adapters with extended clamping range type WE-UL-E, see page 135
Adaptateurs à changement rapide avec gamme de serrage étendue type WE-UL-E, voir page 135
Bussola a cambio rapido con campo di serraggio aumentato tipo WE-UL-E, vedi pagina 135

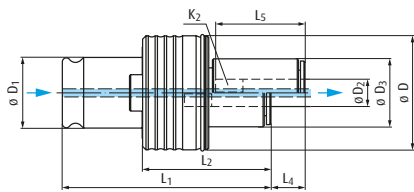

MIT LÄNGENNACHSTELLUNG, MIT ÜBERLASTKUPPLUNG
WITH LENGTH ADJUSTMENT, WITH OVERLOAD CLUTCH
AVEC RÉGLAGE DE LONGUEUR, AVEC ACCOUPLEMENT DÉBRAYABLE
CON REGOLAZIONE DELLA LUNGHEZZA, CON FRIZIONE

		M1 - M9	M3,5 - M14	M6 - M24	M14 - M36	M24 - M56
$\varnothing D$		24	33	50	72	95
$\varnothing D_1$		13	19	31	48	60
$\varnothing D_3$		13	18	30	47	58
L_1		49	55	94	137	205
L_2		29	33	59	81	142
L_4		8	10	15	25	40

ISO		WE 00-UL/ISO	WE 01-UL/ISO	WE 03-UL/ISO	WE 04-UL/ISO	WE 05-UL/ISO			
$\varnothing D_2$	K_2	L_5	L_5	L_5	L_5	L_5			
2,24	1,8	M3	20	A7200.E0006					
2,5	2	M1 - M2	20	A7200.E0011					
2,5	2	M3,5	20	A7200.E0012					
2,8	2,24	M2,2 - M2,6	21	A7200.E0026					
3,15	2,5	M3	21	A7200.E0031					
3,15	2,5	M4	21	A7200.E0032					
3,55	2,8	M3,5	21	A7200.E0041	22	A7201.E0141			
3,55	2,8	M4,5	21	A7200.E0042	22	A7201.E0142			
4	3,15	M4	22	A7200.E0051	23	A7201.E0151			
4	3,15	M5	22	A7200.E0052	23	A7201.E0152			
4,5	3,55	M4,5	22	A7200.E0061	23	A7201.E0161			
4,5	3,55	M6	22	A7200.E0062	23	A7201.E0162			
5	4	M5	23	A7200.E0076	24	A7201.E0176			
5,6	4,5	M7	23	A7200.E0086	24	A7201.E0186			
6,3	5	M6	24	A7200.E0091	25	A7201.E0191	38	A7203.E0391	
6,3	5	M8	24	A7200.E0092	25	A7201.E0192	38	A7203.E0392	
7,1	5,6	M7	M9	24	A7200.E00A6	25	A7201.E01A6	38	A7203.E03A6
8	6,3	M8	M10 - M11	26	A7201.E01B6	39	A7203.E03B6		
9	7,1	M9	M12	27	A7201.E01C6	40	A7203.E03C6		
10	8	M10		28	A7101.E01A6	41	A7103.E03A6		
11,2	9	M14		29	A7201.E01E6	42	A7203.E03E6	55	A7204.E04E6
12,5	10	M16		43	A7203.E03F6	56	A7204.E04F6		
14	11,2	M18 - M20		44	A7203.E03G6	57	A7204.E04G6		
16	12,5	M22		46	A7203.E03H6	59	A7204.E04H6		
18	14	M24		48	A7203.E03J6	61	A7204.E04J6	95	A7205.E05J6
20	16	M27 - M30		63	2)	63	A7104.E04G6	97	A7105.E05G6
22,4	18	M33		65	2)	65	A7204.E04L6	99	A7205.E05L6
25	20	M36		67		67	A7104.E04J6	101	A7105.E05J6
28	22,4	M39 - M42		69		69	A7204.E04N6	103	A7205.E05N6
31,5	25	M45 - M48		105		105	2)	105	A7205.E05P6
35,5	28	M52 - M56					2)		2)
40	31,5	M60 - M64							2)
45	35,5	M68							2)

¹⁾ Bei Verwendung von Gewindebohrern / Gewindeformern mit innerer Kühlschmierstoff-Zufuhr
If used with taps / cold-forming taps with internal coolant-lubricant supply
Pour l'utilisation des tarauds coupants ou à refouler avec lubrification par le centre
Per l'utilizzazione di maschi / maschi a rullare con lubrorefrigerazione interna

²⁾ Schnellwechsel-Einsätze mit erweitertem Spannbereich Typ WE-UL-E siehe Seite 135
Quick-change adapters with extended clamping range type WE-UL-E, see page 135
Adaptateurs à changement rapide avec gamme de serrage étendue type WE-UL-E, voir page 135
Busssole a cambio rapido con campo di serraggio aumentato tipo WE-UL-E, vedi pagina 135

WE-UL-E

NORIS
WE-UL-E-DIN | WE-UL-E-ISO

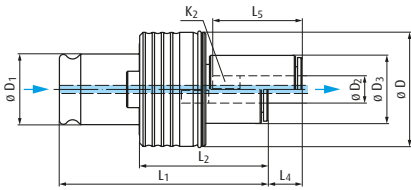

MIT LÄNGENNACHSTELLUNG, MIT ÜBERLASTKUPPLUNG
WITH LENGTH ADJUSTMENT, WITH OVERLOAD CLUTCH
AVEC RÉGLAGE DE LONGUEUR, AVEC ACCOUPLEMENT DÉBRAYABLE
CON REGOLAZIONE DELLA LUNGHEZZA, CON FRIZIONE

		M8 - M11		M16		M27 - M30		M39 - M48		M52 - M60	
$\varnothing D$		24		33		50		72		95	
$\varnothing D_1$		13		19		31		48		60	
$\varnothing D_3$		18		30		50		60		58	
L_1		73		89		147		191		190	
L_2		53,5		67		112		135		127	
L_4		8		10		15		25		40	
DIN		WE 00-UL-E/DIN		WE 01-UL-E/DIN		WE 03-UL-E/DIN		WE 04-UL-E/DIN		WE 05-UL-E/DIN	
$\varnothing D_2$	K_2	L_3		L_3		L_3		L_3		L_3	
8	6,2	M8	M11	26	A7100.E0086						
12	9		M16			41	A7101.E01C6				
20	16		M27					63	A7103.E03G6		
22	18		M30					65	A7103.E03H6		
32	24		M39 - M42							102	A7104.E04L6
36	29		M45 - M48							107	A7104.E04M6
40	32		M52 - M56								83
45	35		M60								83
											A7105.E05N6
											A7105.E05P6

		M8 - M11		M16		M27 - M33		M45 - M56		M52 - M68	
$\varnothing D$		24		33		50		72		95	
$\varnothing D_1$		13		19		31		48		60	
$\varnothing D_3$		18		30		50		60		58	
L_1		73		89		147		191		190	
L_2		53,5		67		112		135		127	
L_4		8		10		15		25		40	
ISO		WE 00-UL-E/ISO		WE 01-UL-E/ISO		WE 03-UL-E/ISO		WE 04-UL-E/ISO		WE 05-UL-E/ISO	
$\varnothing D_2$	K_2	L_3		L_3		L_3		L_3		L_3	
8	6,3	M8	M10 - M11	26	A7200.E00B6						
12,5	10		M16			42	A7201.E01F6				
20	16		M27 - M30					64	A7103.E03G6		
22,4	18		M33					66	A7203.E03L6		
31,5	25		M45 - M48							103	A7204.E04P6
35,5	28		M52 - M56							106	A7204.E04Q6
40	31,5		M60 - M64								79
45	35,5		M68								83
											A7205.E05R6
											A7205.E05S6

¹⁾ Bei Verwendung von Gewindebohrern / Gewindefornern mit innerer Kühlschmierstoff-Zufuhr
If used with taps / cold-forming taps with internal coolant-lubricant supply
Pour l'utilisation des tarauds coupants ou à refouler avec lubrification par le centre
Per l'utilizzazione di maschi / maschi a rullare con lubrorefrigerazione interna

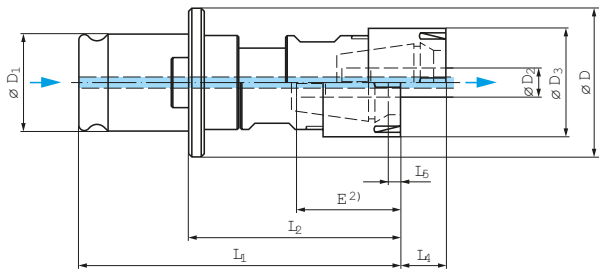

MIT LÄNGENNACHSTELLUNG, OHNE ÜBERLASTKUPPLUNG
WITH LENGTH ADJUSTMENT, WITHOUT OVERLOAD CLUTCH
AVEC RÉGLAGE DE LONGUEUR, SANS ACCOUPLEMENT DÉBRAYABLE
CON REGOLAZIONE DELLA LUNGHEZZA, SENZA FRIZIONE

		$\varnothing D_1$			$\varnothing D$	$\varnothing D_1$	$\varnothing D_3$	L_1	L_2	L_4	L_5	
WE 00-L/ER/MKB	M2 - M8 (Nr.2 - 5/16)	2,5 - 7	ER 11 (GB)	HI-Q/ERM 11	23	13	16	57,5	38	8	0,9	AZ100.E0011
WE 01-L/ER/MKB	M4 - M12 (Nr.8 - 7/16)	4,5 - 9	ER 16 (GB)	HI-Q/ERMC 16	30	19	22	72	50,5	10	5	AZ100.E0116
WE 03-L/ER/MKB	M4 - M20 (Nr.8 - 3/4)	4,5 - 16	ER 25 (GB)	HI-Q/ERMC 25	48	31	35	103	68	15	5	AZ100.E0325

¹⁾ Bei Verwendung von Gewindebohrern / Gewindefornern mit innerer Kühlschmierstoff-Zufuhr
If used with taps / cold-forming taps with internal coolant-lubricant supply
Pour l'utilisation des tarauds coupants ou à refouler avec lubrification par le centre
Per l'utilizzazione di maschi / maschi a rullare con lubrorefrigerazione interna

WE 00-L/ER/MKB:

Spannmutter ohne integrierte Abdichtung ist im Lieferumfang enthalten
Clamping nut without integrated seal is included in the delivery
Écrou de serrage sans étanchéité intégrée est compris dans la livraison
Ghiera de serraggio senza guarnizione è inclusa nella spedizione

WE 01-L/ER/MKB, WE 03-L/ER/MKB:

Spannmutter für Dichtscheiben ist im Lieferumfang enthalten
Clamping nut for sealing disks is included in the delivery
Écrou de serrage pour disques d'étanchéité est compris dans la livraison
Ghiera de serraggio per guarnizioni è inclusa nella spedizione



Eingesetzter Schnellwechsel-Einsatz
Quick-change adapter in assembled condition
Adaptateur à changement rapide monté
Bussola a cambio rapido inserita

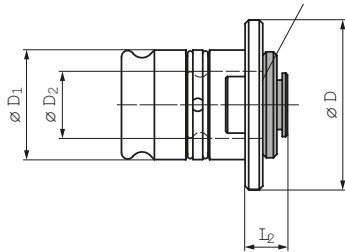

SCHNELLWECHSEL-EINSÄTZE (REDUZIEREINSÄTZE)
QUICK-CHANGE ADAPTERS (REDUCING SLEEVE)
ADAPTATEURS À CHANGEMENT RAPIDE (DOUILLE DE RÉDUCTION)
BUSSOLE A CAMBIO RAPIDO (BUSSOLE DI RIDUZIONE)

		$\varnothing D$	$\varnothing D_1$	$\varnothing D_2$	L_2	
WE 01/00-R	WE 00	30	19	13	11	ABR00.E0100
WE 03/00-R	WE 00	48	31	13	12	ABR00.E0300
WE 03/01-R	WE 01	48	31	19	12	ABR00.E0301
WE 04/01-R	WE 01	70	48	19	13	ABR00.E0401
WE 04/03-R	WE 03	70	48	31	17	ABR00.E0403
WE 05/03-R	WE 03	92	60	31	24	ABR00.E0503
WE 05/04-R	WE 04	92	60	48	27	ABR00.E0504

Beschreibung:

Mit der Typenreihe WE-R können die Spannbereiche nach unten erweitert werden. So lassen sich z.B. in den Reduziereinsatz Type WE 03/01-R alle Schnellwechsel-Einsätze der Größe 01 einsetzen.

Description:

Our quick-change adaptors of series WE-R have been developed to allow for smaller clamping ranges. For example, this enables all size 01 quick-change adaptors to be used in the reducing sleeve WE 03/01-R.

Description:

Les adaptateurs à changement rapide des séries WE-R ont été étudiés pour permettre l'utilisation d'une gamme inférieure. Exemple: Cela permet l'utilisation de tous les adaptateurs à changement rapide série 01 dans la douille de réduction WE 03/01-R.

Descrizione:

Con le bussole Tipo WE-R possono essere ridotti i campi di serraggio. E così possibile utilizzare tutte le dimensioni delle bussole grandezza 01 nella bussola a cambio rapido Tipo WE 03/01-R



ISP 20 | ISP 30

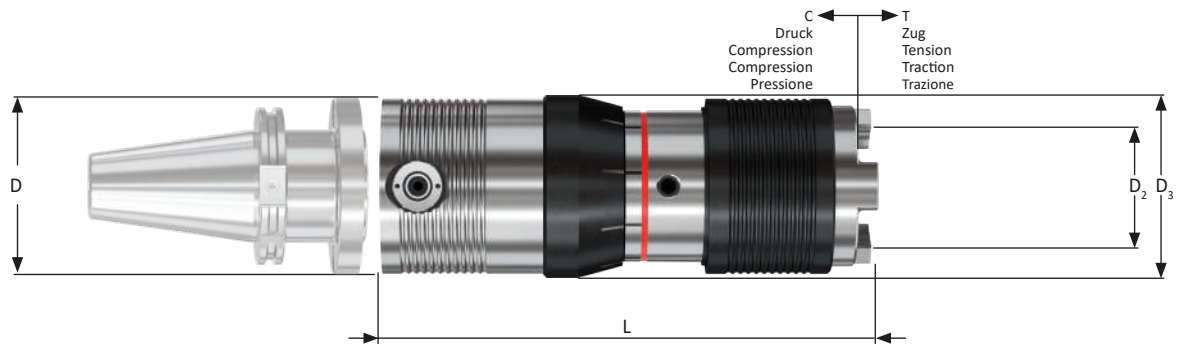

	M24 - M76 (1" - 2 1/2)	M36 - M160 (1 3/8 - 3 1/2)
MAX. DREHMOMENT MAX. TORQUE COUPLE MAXI MOMENTO TORCENTE MAX.	1300 Nm	3000 Nm

ø D	ø D ₁	ø D ₃	L	Kg	C	T	ISP 20	ISP 30
110	75	115	308	14,8	15	15	AFH0.E0220	
160	90	160	372	36,5	20	20		AFH0.E0330

FÜR GEWINDEBOHRER / GEWINDEFORMER
FOR TAPS / COLD-FORMING TAPS
POUR TARAUDS COUPANTS OU À REFOULER
PER MASCHI / MASCHI A RULLARE

DIN

ø D ₂	K ₂		L _s	kg		L _s	kg	
18	14,5	M22 - M24	53	2,2	AFXH2.E0501			
20	16	M27	53	2,2	AFXH2.E0502			
22	18	M30	53	2,1	AFXH2.E0503			
25	20	M33	53	2,1	AFXH2.E0504			
28	22	M36	53	2,1	AFXH2.E0505	76	4,4	AFXH3.E0101
32	24	M39 - M42	53	2	AFXH2.E0506	76	4,3	AFXH3.E0102
36	29	M45 - M48	66	1,9	AFXH2.E0507	76	4,2	AFXH3.E0103
40	32	M52 - M56	66	1,8	AFXH2.E0508	76	4	AFXH3.E0104
45	35	M60	66	1,7	AFXH2.E0509	76	3,9	AFXH3.E0105
50	39	M64 - M90	66	1,6	AFXH2.E0510	76	3,7	AFXH3.E0106
56	44	M92 - M120	66	1,4	AFXH2.E0511	98	3,4	AFXH3.E0107
63	49	M122 - M150				98	3	AFXH3.E0108
70	55	M155 - M160				98	2,7	AFXH3.E0109

ISO

ø D ₂	K ₂		L _s	kg		L _s	kg	
18	14	M24	53	2,2	AFXH2.E0601			
20	16	M27 - M30	53	2,2	AFXH2.E0502			
22,4	18	M33	53	2,1	AFXH2.E0602			
25	20	M36	53	2,1	AFXH2.E0504			
28	22,4	M39 - M42	53	2,1	AFXH2.E0603	76	2,1	AFXH3.E0201
31,5	25	M45 - M48	53	2	AFXH2.E0604	76	2	AFXH3.E0202
35,5	28	M52 - M56	66	1,9	AFXH2.E0605	76	1,9	AFXH3.E0203
40	31,5	M60 - M64	66	1,8	AFXH2.E0606	76	1,8	AFXH3.E0204
45	35,5	M68 - M75	66	1,7	AFXH2.E0607	76	1,7	AFXH3.E0205
50	40	M76 - M90 1)	66	1,6	AFXH2.E0608	76	1,6	AFXH3.E0206
56	45	M92 - M100 1)	66	1,4	AFXH2.E0609	98	1,4	AFXH3.E0207

Ausführung mit innerer Kühlschmierstoff-Zufuhr bis 10 bar auf Anfrage erhältlich
Available with internal coolant-lubricant supply up to 10 bar upon request
Version avec lubrification par le centre d'une pression jusqu'à 10 bars disponible sur demande
Esecuzione con lubrorefrigerazione interna fino a 10 bar disponibile a richiesta

ZUM BOHREN UND SENKEN
FOR DRILLING AND COUNTERSINKING
POUR FORAGE ET CHANFREINAGE
PER FORARE E ALLARGARE

	L _s	kg		L _s	kg	
MK 3	25	3,2	AFXH2.E0401			
MK 4	48	3,3	AFXH2.E0402	20	5,9	AFXH3.E0401
MK 5	80	3,4	AFXH2.E0403	50	6	AFXH3.E0402
MK 6				115	5,8	AFXH3.E0403



Innenkegel nach DIN 228 B
Internal taper acc. DIN 228 B
Cône intérieur selon DIN 228 B
Cono interno secondo DIN 228 B

ISP 20 | ISP 30

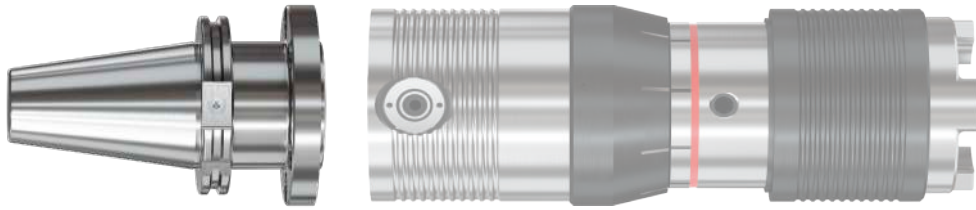

DIN 228 B

	ISP 20			ISP 30		
	L ₂	kg		L ₂	kg	
MK 4	34	1,7	AFYH2.E3404			
MK 5	32	2,8	AFYH2.E3205	30	3,9	AFYH3.E3005
MK 6	31	4,8	AFYH2.E3106	32	6,2	AFYH3.E3206

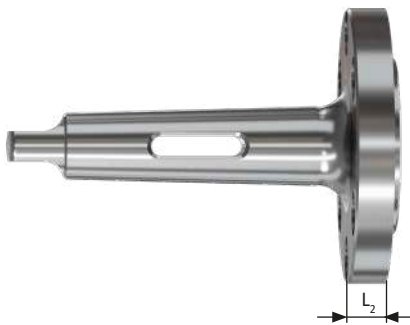

DIN 2080

	ISP 20			ISP 30		
	L ₂	kg		L ₂	kg	
SK 40	22	1,7	AFYH2.E2240			
SK 50	18	3	AFYH2.E1850	19	4,3	AFYH3.E1950



Ausführung mit innerer Kühlschmierstoff-Zufuhr bis 10 bar auf Anfrage erhältlich
 Available with internal coolant-lubricant supply up to 10 bar upon request
 Version avec lubrification par le centre d'une pression jusqu'à 10 bars disponible sur demande
 Esecuzione con lubrorefrigerazione interna fino a 10 bar disponibile a richiesta

DIN 69871 A

	ISP 20			ISP 30		
	L ₂	kg		L ₂	kg	
SK 50	66	3,8	AFYH2.E6650	51	5,8	AFYH3.E5150



Ausführung mit innerer Kühlschmierstoff-Zufuhr bis 10 bar auf Anfrage erhältlich
 Available with internal coolant-lubricant supply up to 10 bar upon request
 Version avec lubrification par le centre d'une pression jusqu'à 10 bars disponible sur demande
 Esecuzione con lubrorefrigerazione interna fino a 10 bar disponibile a richiesta

UNSERE PRÄZISION IST IHR ERFOLG
OUR PRECISION IS YOUR SUCCESS

GEWINDEFRÄSER

Thread mills

7 ...

7 ...

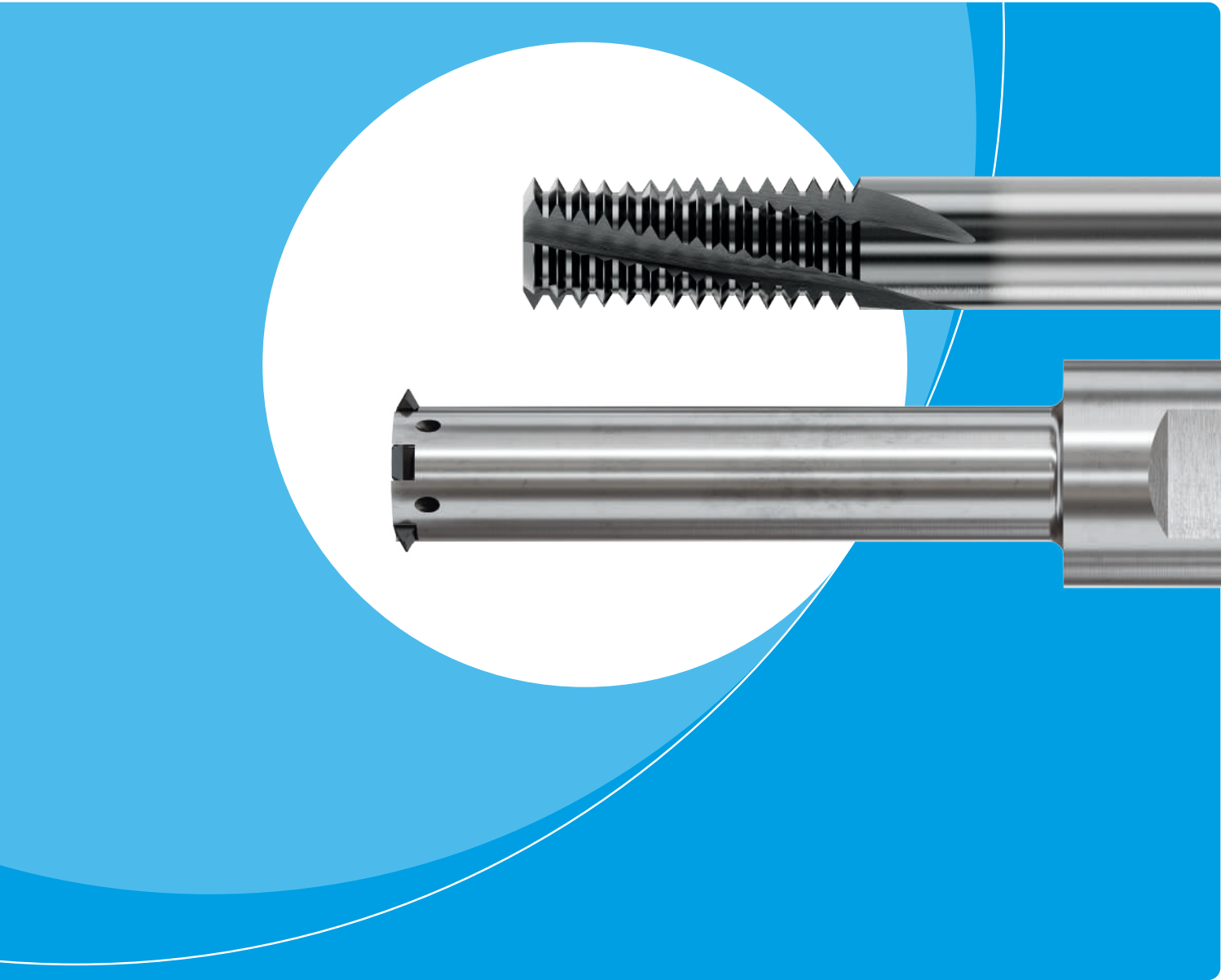



° y o t ° = O " - k o # = u

) @ ° V 8 - 8 - " - V - V ' o # = V @ u 8 - o # = † @) @ M @ - V ' † # ' @ U U @
o @) k @ = u † - k u - y V) U - o o - V) - V @) @ @ y - O - V
° k " - @ o " -) @ 8 y V 8 - V " V 8 - h " o o u † - k) - V



8 y @ - ') - ' o - O # u @ V

O o t ° O y k o - ' † @ - o o -) - # \ y h - ' † # - V U U @ ' @) @ y / - o) ° V o O - o
\ O V V - o k - o h - # u @ - o V - o \ V u j y @) @ * u @ - o - u) \ @ - V u O u k -
') * h u / - o ' @) @ @ y - O - U - V u " y (# \ V) @ @ V o) y o @ ' 8 -



o y U U ° k ' \ 7 ° o o \ k u U - V u

u = - ' O @ u -) # y u u @ 8 o h - -) o ' † # ' @ U U @ " k - ' o u ' V) * k) † ° O y - o
u = @ † ° O y - o = " † - u \ " - ") K y o u -) u \ @) @ @ y * O † \ k M # \ V) @ @ V o



o # - O u ° ') - 8 O @ y u - V o @ @

@ * O k @ @ † - O # @ ") @ ' 8 O @ † # ' @ U U @ j y @ - O - V # * u @ \ V \
h y k ' U - V u - ' @) @ * u @ @ -) - † \ V \ - o o - k - ") * u u ' u @ O - # \ V) @ @ V @ @
h @ 8 \



	ou' = O - k M u \ 77-	ou - OU ' u - k @ O	' # @ ko	' ## @ @
h	y o	y		
	= o	=		
U	k \ au 7 k - @ u ' = O k) y h O @ o	# \ k k \ o @ V " V) " # @ h k \ \ 7 o u - - O #) y h O @	' # @ k o @ \ @ k - o @ u " # @ - o) y h O @	' ## @ @ \ @ - k - o @ u - V u @ 8 O @ # @ @) y h O @
M	8 y o o † - k M u \ 77- 8 M † u 8 ") @ =	# " ou U ' u - k @ O # † ") @ =	7 \ V u - o 7 7 7 ") @ 7	8 = @ - 8 8 8 ") @ 8
N	V @ = u - @ - V † - k M u \ 77- - M - 8 M M M M - O U O u 7 M)	V \ V 7 - k k \ y o U ' u - k @ O - - # # # = - U u 7)	U ' u / k @ y @ \ V 7 - k k - y @ - 7 # - - u h " u	U ' u - k @ O @ \ V 7 - k k \ o @ 0 0 k O 0 0 0 0 k k h
S	ch - @ O - k M u \ 77- V 7 # " o u u	ch - # @ OU ' u - k @ O V 7 # " o u u	U ' u / k @ y @ h / # @ y @ " V 7 # " o u	U ' u - k @ O ch - # @ O @ " V 7 # " o u O
=	8 - / k u - u - † - k M u \ 77- 8 o	= ° k) - V -) ' au - - O =	' # @ k o ' u k ' @ / o	' ## @ @ - U h k ' u @



° y o t ° = 0 - " - k o # = u

) @ " V 8 - 8 - " - V - V o # = V @ u 8 - o # = † () @ M @ - V † # ' U U @
o @) k # = u † - k u - y V) U - o - V) - V () @ y - O V
° k * - @ o -) @ 8 y V 8 - V " V 8 - h ° o o u † - k) - V



8 y @ -) - ' o - 0 # u @ V

0 - o † ° 0 - y k o) - † @ - o o -) - # \ y h - † # - V U U @ () @ y / - o) ° V o 0 - o
\ O V V - o k - o h - # u @ - o V - ' o \ V u j y () @ * u @ - o - u) \ @ - V u O u k -
') * h u / - o @) @ y - O U - V u * y (# \ V) @ @ V o) y o @ * 8 -



o y U U ° k ' \ 7 ° o o \ k u U - V u

u = - O @ u -) # y u u @ 8 o h - -) o † # ' U U @ " k - ' o u V) * k) † ° O y - o
u = o † ° O y - o = † - u \ " - ") k y o u -) u \ () @ y * O † \ k M # \ V) @ @ V o



o # - O u °) - 8 O @ y u - V o @ @

@ * O k @ @ † - O # @ *) @ † 8 O @ † # ' U U @ j y @ - O - V # * u @ \ V \
h y k * U - V u - @) @ * u @ @ -) - † \ V \ - o o - k - ") * u u @ O - # \ V) @ @ V @ @
h @ 8 \



	ou' = O - k M u \ 77-	ou - O U ° u - k @ O	' # @ k o	' # # @ @
h	y o	y		
	= o	=		
U	k \ au 7 k - @ u ' = 0 k) y h O @ o	# \ k k \ o @ V " V) " # @ h k \ \ 7 o u - - O #) y h O @	' # @ k o @ \ E k - o @ u " # @ - o) y h O @	' # # @ @ \ E - k - o @ u - V u @ 8 O @ # @ @) y h O @
M	8 y o o † - k M u \ 77- 8 M u † u 8) @ =	# ° ou U ° u - k @ O # †) @ =	7 \ V u - o 7 7 7) @ 7	8 = @ - 8 8 8) @ 8
N	V @ = u - @ - V † - k M u \ 77- - M - 8 M M M M - 0 U 0 u 7 M)	V \ V 7 - k k \ y o U ° u - k @ O - - # # # = - U u 7)	U ° u / k @ y @ \ V 7 - k k - y @ - 7 # - - u h u	U ° u - k @ @ \ V 7 - k k \ o @ 0 0 k 0 0 0 0 k k h
S	o h - - @ O - k M u \ 77- V 7 # " o u u	o h - # @ O U ° u - k @ O V 7 # " o u u	U ° u / k @ y @ h / # @ y @ " V 7 # " o u	U ° u - k @ @ o h - # @ @ " V 7 # " o u 0
=	8 - = / k u - u - † - k M u \ 77- 8 o	= ° k) - V -) ' o u - - O =	' # @ k o u k ° @ / o	' # # @ @ - U h k ° u @



2xD)

	V-o` V-o`uo	V-o-
U
U 7
yV#
yV7
G
Vhu

U`u	†` u@/	†` u@O/	fz [mm]	†` fz [mm] 2xD)
V` h`	h	h
V` h`	h	h
V` h`	h	h
V` h`	h	h
	†` u@/	†` u@O/	fz [mm]	†` fz [mm] 2xD)
V` U`	h	h
V` U`	h	h
	†` u@/	†` u@O/	fz [mm]	†` fz [mm] 2xD)
V` M	h	h
V` M	h	h
	†` u@/	†` u@O/	fz [mm]	†` fz [mm] 2xD)
V` V`	h	h
o` V`	h	h
o` V`	h	h
V` V`	h	h
V` V`	h	h
V` V`	h	h
V` V`	h	h
V` V`	h	h
V` V`	h	h
	†` u@/	†` u@O/	fz [mm]	†` fz [mm] 2xD)
V` o`	h	h
V` o`	h	h
V` o`	h	h
V` o`	h	h
	†` u@/	†` u@O/	fz [mm]	†` fz [mm] 2xD)
=k` =`	h	
=k` =`		
=k` =`		

mKB
≥ M8

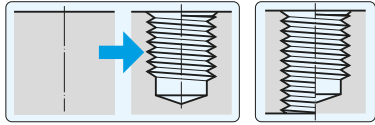
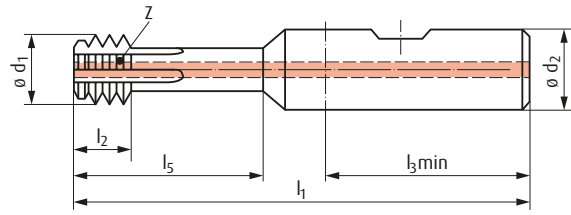

U " - k70 # = - " "oyk7 # -
oyk7 # - " "oyh-k7@@
0# = V - @ ou\ 77 " U " u - k @ O
U " u @ k - " U " u - k @ O

Q/

M

M 3	x	2,3	6	2	36	7	4	F154HBF00306	
M 4	x 0,7	3	6	2,8	36	9,4	4	F154HBF00406	
M 5	x 0,8	3,8	6	3,2	36	11,6	4	F154HBF00506	
M 6 - M 7	x 1	4,6	8	60	4	36	14	4	F154HBF00606
M 8 - M 10	x	6,2	10	71	40	19	4	F154HBF00806	
M 10 - M 12	x	10	76	6	40		4	F154HBF01006	
M 12 - M 14	x	9,2	12	86	7	31	4	F154HBF01126	
M 14 - M 16	x 2	11,1	16	98	8	48	36	4	F154HBF01146

mKB

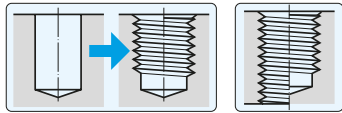
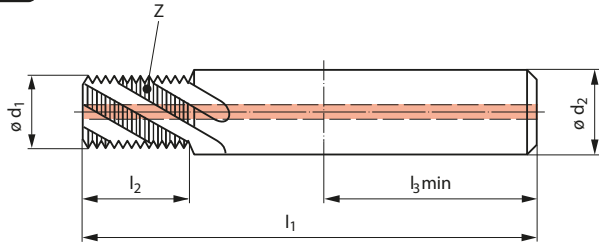

) @' '=""



\ " - k7O' # = - " 'oy k7' # -
oy k7' # - " 'oy h- k7@ @
o# = V - @ ou\ 77 ' U ' u - k @ O
U ' u @ k - ' U ' u - k @ O

' #k

M

ϕD	P	ϕd_1	ϕd_2	l_1	l_2	Z	
M 3	- 0,5	2,4	6		6,2	3	F312HBF000309
M 4	- 0,7		6		8,7	3	F312HBF000409
M 5	- 0,8	4	6		10,8	3	F312HBF000509
M 6	- 1	4,8	6			3	F312HBF000609
M 8	- 1,25		8	63	16,8	3	F312HBF000809
M 10	- 1,5	8,2	10	70	21,7	4	F312HBF001009
M 12	- 1,75	9,9	10	74		4	F312HBF001129
M 14	- 2	11,6	12		28,9	4	F312HBF001149
M 16	- 2	13,6	14	90	32,9	4	F312HBF001169
MF 5 x 0,5		4,34	6		10,2	3	F312HBF002189
MF 6 x 0,75			6		12,4	3	F312HBF002299
MF 8 x 0,75		6,9	8	63	16,1	3	F312HBF002509
MF 8 x 1		6,7	8	63		3	F312HBF002519
MF 10 x 1		8,7	10	70		4	F312HBF002769
MF 12 x 1		9,9	10	74		4	F312HBF003019
MF 12 x 1,5		9,9	10	74	24,7	4	F312HBF003039
MF 14 x 1,5		11,9	12		29,2	4	F312HBF003319
MF 16 x 1,5		13,9	14	90	33,7	4	F312HBF003599
UNC Nr. 10 - 24			6		10	3	F312HBF050079
UNC 1/4 - 20		4,7	6		13,3	3	F312HBF050099
UNC 5/16 - 18			8	62	16,2	3	F312HBF050109
UNC 3/8 - 16			8		19,8	3	F312HBF050119
UNC 7/16 - 14		9	10	74	22,6	3	F312HBF050129
UNC 1/2 - 13		10,32	12	80	26,3	4	F312HBF050139
UNC 9/16 - 12		11,8	12		30,6	4	F312HBF050149
UNC 5/8 - 11		13,1	14	90	33,4	4	F312HBF050159
UNC 3/4 - 10			16	100	39,3		F312HBF050169
UNF Nr. 10 - 32		3,9	6		10,7	3	F312HBF050419
UNF 1/4 - 28			6		13,1	3	F312HBF050439
UNF 5/16 - 24		6,6	8	62	16,4	3	F312HBF050449
UNF 3/8 - 24		8,2	10	70		4	F312HBF050459
UNF 7/16 - 20			10	74		4	F312HBF050469
UNF 1/2 - 20		11,1	12	80	26	4	F312HBF050479
UNF 9/16 - 18			14		28,9	4	F312HBF050489
UNF 5/8 - 18		13,9	14	90	33,1		F312HBF050499
UNF 3/4 - 16			16	100	38,9		F312HBF050509
G 1/8	28	7,9	8	63	16,8		F312HBF095409
G 1/4	19	9,9	10	70	20,7	6	F312HBF095459
G 1/2	14	11,9	12	80	26,3		F312HBF095489
G 1/2	14		16	90	33,6	6	F312HBF095499
G 1"	11		16	90			F312HBF095509
NPT >1/16	27		8	60	13,6	4	F312HBF096769
NPT >1/4	18		12	80	20,4	4	F312HBF096779
NPT >1/2	18		16		26,3	4	F312HBF096789
NPT >1"	14	19,6	20		32		F312HBF096799

Hinweis: ' 8' Vhu@
Note: ' 8' Vhu'
Remarque: ' 8' Vhu'
Nota: ' 8' Vhu'

' 8 M u Vhu'o 'Vhu7o
'u # =) u Vhu'h 'Vhu7h
'u Vhu'h 'Vhu7h
'u Vhu'h 'Vhu7h

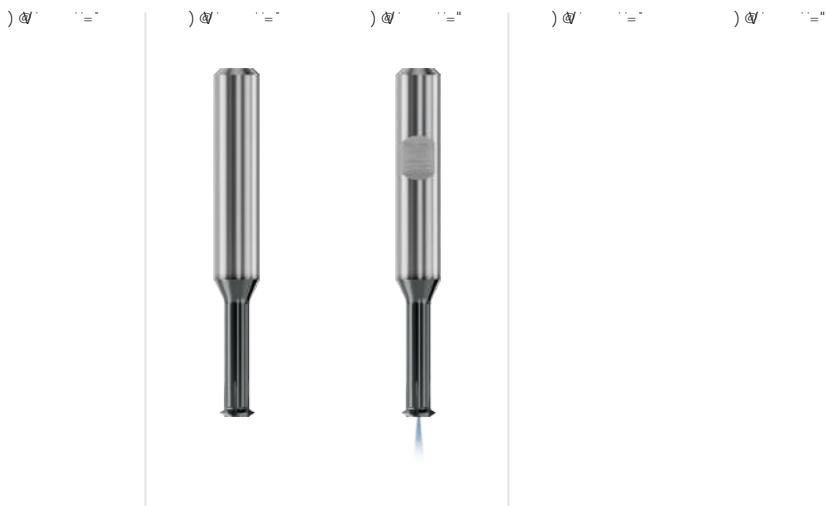
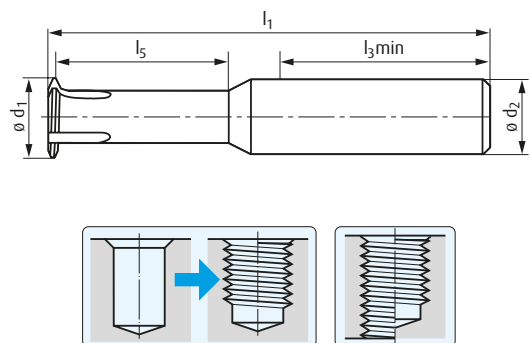

\ " - k70 # = - " oy k7 # - oy k7 # - " oy h - k7 @ @ 0 # = V - @ ou \ 77 " U " u - k @ O U " u @ k - " U " u - k @ O										° Q @	° # k	° # k
∅ D _{min}	P	P _{max}	∅ d ₁	∅ d ₂	l ₁	l _{3 min}	l ₅	Z	M	M	M	
M 1 - 0,25			0,74 0,7 0,7	3	32	28	3	4	F500HAF00109	F50ES0522368	F51EHAF00105	
M 1,2 - 0,25			0,9 0,7 0,7	3	32	28	2,8	1	F500HAF00129	F50ES0522368	F51EHAF00105	
M 1,4 - 0,3	0,3		1,0 1,04	3	32	28	4	2	F500HAF00149	F50ES0522369	F51EHAF00165	
M 1,6 - 0,35			1,2 1,04 1,18	3	32	28	4,0	2	F500HAF00169	F50ES0522369	F51EHAF00165	
M 1,7 - 0,35	0,4		1,2 1,04	3	32	28	4	2	F500HAF00169	F50ES0522369		
M 1,8 - 0,35			1,04	3	32	28	4	2	F500HAF00189	F50ES0522369		
M 2 - 0,4			3	3	32	28	4	3	F500HAF00209	F50ES0522370	F51EHAF00205	
M 2,2 - 0,45	0,4		3	3	32	28	4,8	3	F500HAF00209	F50ES0522370		
M 2,5 - 0,45			1,9 1,96	3	32	28	6	3	F500HAF00259	F50ES0522371	F51EHAF00255	
M 3 - 0,5	0,6		2,4 3	3	32	28	6	3	F500HAF00309	F50ES0522371	F51EHAF00305	
M 3,5 - 0,6	0,7		2,4 2,8 2,78	3	32	28	6	3	F500HAF00359	F50ES0522372		
M 4 - 0,7	0,8		3,2 2,78	4	40	28	8	3	F500HAF00409	F50ES0522372	F51EHAF00405	
M 5 - 0,8	0,7		4,1 1 0,8	4	40	28	9	4	F500HAF00509	F50EHB000509	F51EHB000509	
M 6 - 1	1		4 4,8	6	40	28	14	4	F500HAF00609	F50EHB000509	F51EHB000609	
M 7 - 1	1		4,9 4	6	40	28	14	4	F500HAF00609	F50EHB000509	F51EHB000609	
M 8 - 1,25			8 8	8	62	36	19,8			F50EHB000809	F51EHB000809	
M 10 - 1,5			8,2	10	62	36	19,8			F50EHB000809	F51EHB001009	
M 12 - 1,75	2		9,9 9,9	10	78	40	31,8			F50EHB001129	F51EHB001129	
M 14 - 2	2		9,9 11,6	10	78	40	31,8			F50EHB001129	F51EHB001149	
M 16 - 2	2		9,9 13,6	10	78	40	31,8			F50EHB001129	F51EHB001169	

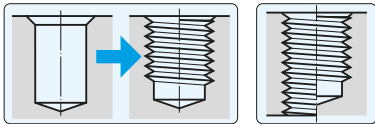
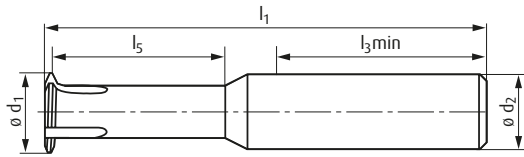

\backslash " - k70' # = - " " oy k7' # -
 oy k7' # - " " oy h- k7@ @
 o# = V - @ ou\ 77 ' U " u- k @ O
 U " u@k - " " U " u- k @ O

#k

M

ϕD_{min}	P	P_{max} mm	ϕd_1 mm	ϕd_2 mm	l_1 mm	$l_3 min$ mm	l_5 mm	Z		
UNC Nr. 2	- 56		1,7	3	39	28	7	3	F51EHAF050019	
UNC Nr. 4	- 40	0,64		3	40	28	9,2	3	F51EHAF050039	
UNC Nr. 6	- 32	0,79	2,7	3	42	28	11,3	3	F51EHAF050059	
UNC Nr. 10	- 24	1,06	3,7	4	46	28		3	F51EHAF050079	
UNC 1/4	- 20	1,27		6		36	20,3	4		F51EHBf050099
UNC 5/16	- 18	1,41	6,3	8		36		4		F51EHBf050109
UNC 3/8	- 16		7,7	8	68	36	30,2			F51EHBf050119
UNF Nr. 10	- 32	0,79	3,9	4	46	28		4	F51EHAF050419	
UNF 1/4	- 28	0,91		6		36	20	4		F51EHBf050439
UNF 5/16	- 24	1,06	6,6	8		36	24,9			F51EHBf050449
UNF 7/16	- 20	1,27		10	77	40	34,6			F51EHBf050469



mm	M / MF P mm	UN P 1/2"	NPT P 1/2"	G P 1/2"		D ₁ mm		l ₅ mm	ø d ₂ mm	l ₁ mm	z		
≥ ø 17,50	14	F521			45	20	100	2	F501F0003	
≥ ø 20,00		F522	18	FK 16,5/18	60	20	114	2	F501F0005	
≥ ø 21,00	14	F521		FK 20,5/22	50	16	100	3	F501F0019	
≥ ø 23,50		F522	22					4		F701F0016
								60	32	124	3	F501AANAA	
≥ ø 25,50	11	F510		FK 24	80	32	144	3	F501F0011	
					F710		FK 24	90	32	144	3	F501AARAA	
					F510		FK 29,5	95	32			F501AA8AA	
≥ ø 29,00		F710		FK 24	60	32	124			F701F0015
≥ ø 31,50	11	F750	27	FK 27	90	32				F701F0003
					F510	29,27	FK 29,5	95	32		3	F501E0841	
≥ ø 35,00	11	F511		FK 33	95	32		3	F501F0012	
					F711		FK 33	115	32	179	3	F501AAPAA	
								115	32	179		F501F0007	F701F0001
≥ ø 43,00	8	11	F512		FK 40,5	110	32	173	4	F501F0013	
								145	32	208	4	F501F0010	

O
o

t
"
h

\
u
h

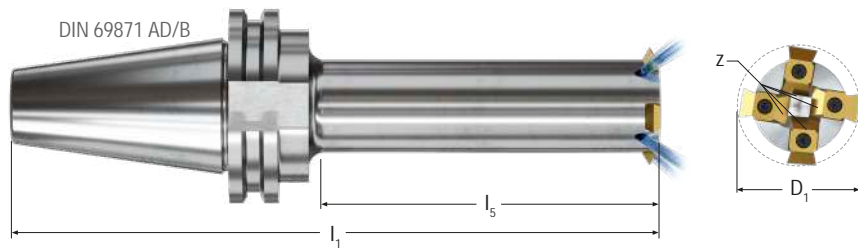

mm	M / MF P mm	UN P 1/"	NPT P 1/"	G P 1/"		D ₁ mm		l ₅ mm	∅ d ₂ mm	l ₁ mm	z	
≥ ∅ 43,00	8	11	F512	FK 40,5	110	"u	217	4	F505F0029	
								"u	264	4	F505AADAF	
								∅M	212	4	F505AADAA	
								∅M		4	F505AADAC	
								"u		4	F505F0028	
								"u	299	4	F505F0025	
							145	∅M	247	4	F505AAWAA	
								∅M	280	4	F505AAWAB	
								"u		4	F505F0031	
								∅M		4	F505AAEAA	
								∅M	286	4	F505AAEAB	
								"u		4	F505F0026	
≥ ∅ 56,00	8	11	F513	FK 53	150	∅M	330	7	F505F0007	
								"u	327	7	F505F0042	
								∅M	308	7	F505AACAA	
							195	"u	417	7	F505F0034	
								∅M	398	7	F505E5553	
								∅M	397	10		
≥ ∅ 70,50	8	11	F513	FK 67	170	∅M	397	10		
								"u	397	10		
								∅M	397	10		
							260	"u	417	7	F505F0034	
								∅M	398	7	F505E5553	
								∅M	397	10		
≥ ∅ 100,00	..	4	F514	92	FK 92	∅M	341	7	F505AA2AA	
								∅M	497	7	F505F0008	
								∅M	360	7		

O † " o
 o u
 # h
 †
 " †
 h
 #
 \

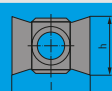

o# = V - @ ou \ 77 U u - k @ O
U u @ k - U u - k @ O
\" - k 7 O # = - oy k 7 # -
oy k 7 # - oy h - k 7 @ @

										M	M	
										TIN	u @ O	
ø D		ø D _{1 min} mm		l mm	h mm	b mm	M / MF	UN	NPT	G		
FK 16,5/18	F521			7		3,18	14	F521F0002	F521F0004
	F522	18		7,8		3,18		F521F0005	F521F0008
FK 20,5/22	F521			7		3,18	14	F522F0001	F522F0002
	F522	22		7,8		3,18		F521F0002	F521F0004
											F521F0005	F521F0008
F522F0001	F522F0002											
FK 24	F510					3,3	11		
	F710					3,3			F710F0001
FK 27	F750	27				3,3			
FK 29,5	F510	29,27				3,3	11		
FK 33	F511					3,97	11		
	F711		10	7		3,97			F711F0001
FK 40,5	F512						8	11		
FK 53	F513		19			6	11		
FK 67	F513		19			6	11		
FK 92	F514	92		14,3			..	4	..			

Andere Gewinnesysteme auf Anfrage, z.B.: | Other thread standards upon request, e.g.: | Autres standards de filetage sur demande, p.ex.: | Altri sistemi di filettatura su richiesta, p. es.:

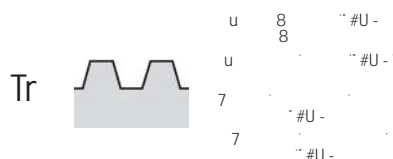

Sonderkonturen auf Anfrage | Special contours upon request | Profils spéciaux sur demande | Profili speciali su richiesta



M	M					
TIN	u@Q			M _D Nm		
		M2,5	⊕	0,9	F550F0001	1033F0001
		M2,5	⊕	0,9	F550F0001	1033F0001
F510AAAAA	F510F0012	M2,5	⊕	0,9	F550F0001	1033F0001
F510AACAA	F510F0003					
F510AABAA	F510F0005					
	F510F0004					
	F750F0002	M2,5	⊕	0,9	F550F0001	1033F0001
	F510F0012	M2,5	⊕	0,9	F550F0001	1033F0001
F510AAAAA	F510F0003					
F510AACAA	F510F0005					
F510AABAA	F510F0004					
F511AAAAA	F511F0001	M3	⊕		F550F0002	1033F0002
F511AACAA	F511F0003					
F511AABAA	F511F0002					
F512AAAAA	F512F0001	M4	⊕		F550F0003	1033F0003
F512AACAA	F512F0003					
F512AABAA	F512F0002					
F513AAAAA	F513F0001	M5	⊕	8	F550F0004	1033F0004
F513AACAA	F513F0003					
F513AABAA	F513F0002					
F513AAAAA	F513F0001	M5	⊕	8	F550F0004	1033F0004
F513AACAA	F513F0003					
F513AABAA	F513F0002					
F514AAAAA	F514F0005	M5	⊕	8	F550F0005	1033F0004

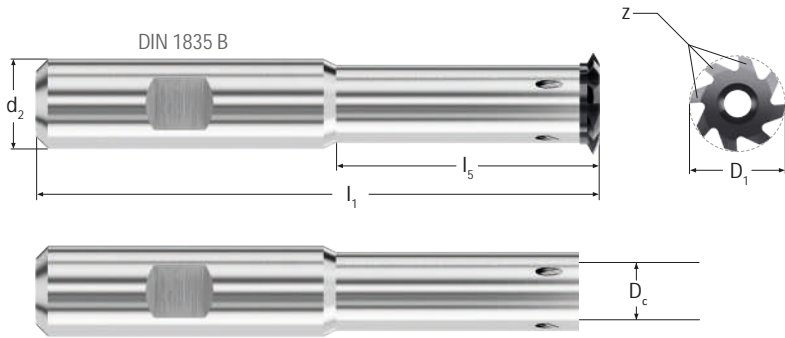

$\varnothing D_{min}$ mm	M / MF P mm	UN P 1/2"	G P 1/2"	D	$\varnothing d_2$ mm	z	l_1 mm	l_5 mm		l_1 mm	l_5 mm		
12	8'	..	$\varnothing 5,4$	10	6	68	24	F50ZNES1010	74	30	F50ZNES1017
14	8'	..	$\varnothing 6,5$	10	7	..	28	F50ZNES1011	F50ZNES1018
16	8'	..	$\varnothing 7,9$	12	8	78	32	F50ZNES1023	86	40	F50ZNES1016
20	8' 8'	..	$\varnothing 9,2$	14	8	88	40	F50ZNES1012	98	..	F50ZNES1019
24	8'	..	$\varnothing 11,4$	16	8	99	48	F50ZNES1013	111	60	F50ZNES1020
30	8'	..	$\varnothing 14,6$	20	9	..	60	F50ZNES1014	130	..	F50ZNES1021
36	8'	..	$\varnothing 17,8$..	10	133	72	F50ZNES1015	..	90	F50ZNES1022

O
o

t
"
h

\



ACR



ACR

D	Ø D _{min.} mm	l _s mm	Ø d ₁ mm	z	M / MF P mm	UN P 1/"		G		
									P 1/"	
Ø 5,4	12	24	9,9	6	F52ZNES10912	8'	..	F52ZNES10945
Ø 6,5	14	28	11,6	7	F52ZNES20912	8'	..	F52ZNES20945
Ø 7,9	16	32	13,6	8	F52ZNES70912	8'	..	F52ZNES70945
Ø 9,2	20	40		8	F52ZNES30914	8' 8'	..	F52ZNES30948
Ø 11,4	24	48	19,9	8	F52ZNES40914	8'	..	F52ZNES40950
Ø 14,6	30	60	24,9	9	F52ZNES50916	8'	..	F52ZNES50950
Ø 17,8	36	72	29,9	10	F52ZNES60918	8'	..	F52ZNES60950

NES-Z

D		M ₁ Nm			
Ø 5,4	M2,5 x 8,5	0,9		F550F0001	1033F0001
Ø 6,5	M3 x 11			F550F0002	1033F0002
Ø 7,9	M3 x 11			F550F0002	1033F0002
Ø 9,2	M4 x 13			F550F0003	1033F0003
Ø 11,4	M5 x 15	8		F550F0004	1033F0004
Ø 14,6	M5 x 15	8		F550F0004	1033F0004
Ø 17,8	M5 x 15	8		F550F0004	1033F0004

UNSERE PRÄZISION IST IHR ERFOLG
OUR PRECISION IS YOUR SUCCESS

SPIRALBOHRER

TWIST DRILL

FORET

PUNTA ELICOIDALE





AUSWAHLÜBERSICHT

DIE ANGEGEBENEN SCHNITTWERTE SIND RICHTWERTE UND MÜSSEN DEN INDIVIDUELLEN ARBEITSBEDINGUNGEN ANGEPAST WERDEN.



GUIDE DE SELECTION

LES VALEURS DE VITESSE DE COUPE INDIQUEES DANS LES COLONNES RESPECTIVES NE SONT QU'INDICATIVES ET DOIVENT ETRE ADAPTEES INDIVIDUELLEMENT AUX CONDITIONS D'USINAGE.



SUMMARY OF ASSORTMENT

THE LISTED CUTTING DATA ARE STANDARD VALUES. THIS VALUES HAVE TO BE ADJUSTED TO INDIVIDUAL WORK CONDITIONS.



SCELTA DEGLI UTENSILI

I VALORI DI VELOCITÀ DI TAGLIO QUI ELENCATI SONO PURAMENTE INDICATIVI E DEVONO ESSERE ADATTATI ALLE CONDIZIONI D'IMPIEGO.



	STAHLWERKSTOFFE	STEEL MATERIALS	ACIERS	ACCIAI
P	Un- und niedriglegierte Stähle	Unalloyed and low-alloy steels	Aciers non et faiblement alliés	Acciai non legati e basso legati
	Hochlegierte Stähle	High alloy steels	Aciers hautement alliés	Acciai alto legati
M	ROSTFREI STÄHLE	CORROSION AND ACID PROOF STEELS	ACIERS INOX/RESIST. ACIDES	ACCIAI INOX E RESISTENTI AGLI ACIDI
	Rostfreie austenitische Stähle + DUPLEX Stähle	Corrosion and acid proof steels + DUPLEX	Aciers inoxydables austénitiques + Aciers DUPLEX	Acciai inossidabili austenitici + Acciai DUPLEX
K	GUSSWERKSTOFFE	CAST MATERIALS	FONTES	GHISE
	Grauguss, Kugelgraphitguss, Vermiculargraphitguss, Temporguss	Cast iron, nodular cast iron, Vermicular graphite cast iron, malleable cast iron	Fonte grise, fonte à graphite sphéroïdal, Fonte à graphite vermiculaire, Fonte malléable	Ghisa grigia, ghisa nodulare, Ghisa a grafite vermiculata, ghisa malleabile
	Gusseisen ausferritisch (ADI) + Hartguss	Ausferritic cast iron (ADI) + Hard casting	Fonte ausferritique (ADI) + Fontes trempées	Ghisa ausferritica (ADI) + Ghise in conchiglia
N	NICHTEISEN-WERKSTOFFE	NON FERROUS MATERIALS	MATÉRIAUX NON FERREUX	MATERIALI NON FERROSI
	Aluminium-Knetlegierungen	Aluminium wrought alloys	Alliages d'aluminium corroyés	Leghe malleabili di alluminio
	Aluminium-Gusslegierungen	Aluminium cast alloys	Fontes d'alu	Leghe fuse di alluminio
	Kupfer + Kupferlegierungen (langsp.)	Copper + Copper alloys (long-chip.)	Cuivre + Alliages cuivre (cop. longs)	Rame + Leghe rame (truciolo lungo)
	Kupferlegierungen (kurzsp.)	Copper alloys (short-chip.)	Alliages cuivre (cop. courts)	Leghe rame (truciolo corto)
	Kupferlegierungen hochfest	High-strength copper alloys	Alliages cuivre haute résistance	Leghe rame ad alta resistenza
	Zink-Legierungen	Zinc alloys	Alliages de zinc	Leghe zinco
	Magnesium-Legierungen	Magnesium wrought alloys	Alliages de magnésium corroyés	Leghe malleabili di magnesio
	Thermoplaste	Thermoplastics	Thermoplastiques	Resine termoplastiche
	Faserverstärkte Kunststoffe + Duroplaste	Fibre-reinforced synthetics + Duroplastics	Plastiques chargées en fibres + Thermodurcissables	Resine epossidiche + Plastiche termoindurenti
S	SPEZIALWERKSTOFFE	SPECIAL MATERIALS	MATÉRIAUX SPÉCIAUX	MATERIALI SPECIALI
	Ni-, Fe- oder Co- Basis- Superlegierungen	Ni-, Fe- or Co- base- Superalloys	Base Ni, Fe ou Co- Superalliages	A base Ni-, Fe- o Co- Superleghe
	Titan + Titanlegierungen	Titanium + Titanium alloys	Titane + Alliages de titane	Titanio + Leghe di titanio
H	GEHÄRTETE WERKSTOFFE	HARDENED STEELS	ACIERS TRAITÉS	ACCIAI TEMPRATI
	Gehärtete Stähle	Hardened steels	Aciers traités	Acciai temprati

NORIS DRILLREX UNI

DIN 6535 HA



TIBLU
VHM

160 - 163

NORIS DRILLREX-C UNI

DIN 6535 HA



TIBLU
VHM

164

	MAT.	Vc (m/min)			d ₁ = 3 mm			d ₁ = 5 mm			d ₁ = 8 mm			f (mm/U) d ₁ = 10 mm			d ₁ = 12 mm			d ₁ = 16 mm			d ₁ = 20 mm		
		MIN	MED	MAX	MIN	MED	MAX	MIN	MED	MAX	MIN	MED	MAX	MIN	MED	MAX	MIN	MED	MAX	MIN	MED	MAX	MIN	MED	MAX
≤ 800 N/mm ²	P 1.1	110	140	170	0,04	0,05	0,06	0,065	0,08	0,10	0,10	0,13	0,16	0,13	0,17	0,20	0,155	0,20	0,24	0,21	0,26	0,32	0,26	0,33	0,40
≤ 1200 N/mm ²	P 1.2	60	80	100	0,035	0,05	0,055	0,055	0,08	0,095	0,09	0,12	0,15	0,10	0,15	0,19	0,14	0,18	0,23	0,18	0,24	0,30	0,23	0,31	0,38
≤ 1400 N/mm ²	P 1.3	50	60	70	0,03	0,03	0,035	0,035	0,05	0,055	0,055	0,07	0,09	0,07	0,09	0,10	0,085	0,11	0,14	0,11	0,15	0,18	0,14	0,19	0,23
≤ 1400 N/mm ²	P 2.1	45	70	90	0,03	0,04	0,06	0,06	0,08	0,10	0,09	0,11	0,13	0,11	0,13	0,15	0,13	0,15	0,17	0,15	0,17	0,21	0,19	0,21	0,21
		MIN	MED	MAX	MIN	MED	MAX	MIN	MED	MAX	MIN	MED	MAX	MIN	MED	MAX	MIN	MED	MAX	MIN	MED	MAX	MIN	MED	MAX
≤ 800 N/mm ²	M 1.1	50	60	70	0,04	0,05	0,07	0,08	0,10	0,12	0,10	0,12	0,14	0,12	0,14	0,16	0,14	0,16	0,18	0,16	0,18	0,22	0,20	0,22	0,22
≤ 1300 N/mm ²	M 1.2	30	45	60	0,03	0,04	0,06	0,06	0,08	0,10	0,09	0,11	0,13	0,11	0,13	0,15	0,13	0,15	0,17	0,15	0,17	0,21	0,19	0,21	0,21
		MIN	MED	MAX	MIN	MED	MAX	MIN	MED	MAX	MIN	MED	MAX	MIN	MED	MAX	MIN	MED	MAX	MIN	MED	MAX	MIN	MED	MAX
≤ 800 N/mm ²	K 1.1	100	130	160	0,045	0,05	0,06	0,075	0,09	0,10	0,12	0,14	0,16	0,15	0,18	0,20	0,18	0,21	0,24	0,24	0,28	0,32	0,30	0,35	0,40
≤ 1400 N/mm ²	K 2.1																								
		MIN	MED	MAX	MIN	MED	MAX	MIN	MED	MAX	MIN	MED	MAX	MIN	MED	MAX	MIN	MED	MAX	MIN	MED	MAX	MIN	MED	MAX
	N 1.1	250	350	450	0,09	0,10	0,12	0,16	0,18	0,2	0,25	0,30	0,35	0,25	0,31	0,37	0,30	0,35	0,40	0,40	0,44	0,48	0,50	0,55	0,60
≤ 12% Si	N 1.2	250	300	350	0,08	0,09	0,10	0,14	0,16	0,17	0,20	0,26	0,32	0,20	0,27	0,34	0,24	0,30	0,37	0,32	0,38	0,44	0,40	0,50	0,55
≥ 12% Si	N 1.3																								
	N 2.1	160	200	240	0,08	0,09	0,10	0,11	0,13	0,14	0,18	0,20	0,22	0,23	0,25	0,27	0,27	0,30	0,33	0,36	0,40	0,44	0,45	0,50	0,55
	N 2.2	250	300	350	0,10	0,11	0,12	0,14	0,15	0,16	0,22	0,24	0,26	0,28	0,30	0,33	0,33	0,36	0,39	0,44	0,48	0,52	0,55	0,6	0,65
≥ 800 N/mm ²	N 2.3	50	65	80	0,03	0,05	0,05	0,05	0,06	0,07	0,08	0,09	0,10	0,09	0,10	0,13	0,10	0,12	0,14	0,12	0,13	0,16	0,14	0,16	0,19
	N 3.1	200	300	400	0,09	0,10	0,12	0,16	0,18	0,20	0,25	0,30	0,35	0,25	0,31	0,37	0,30	0,35	0,4	0,40	0,44	0,48	0,50	0,55	0,60
	N 4.1	200	300	400	0,09	0,10	0,12	0,16	0,18	0,20	0,25	0,30	0,35	0,25	0,31	0,37	0,30	0,35	0,4	0,40	0,44	0,48	0,50	0,55	0,60
	N 5.1																								
	N 5.2	40	50	60	0,02	0,03	0,04	0,03	0,05	0,06	0,05	0,06	0,08	0,07	0,08	0,09	0,09	0,10	0,11	0,11	0,12	0,14	0,13	0,14	0,14
		MIN	MED	MAX	MIN	MED	MAX	MIN	MED	MAX	MIN	MED	MAX	MIN	MED	MAX	MIN	MED	MAX	MIN	MED	MAX	MIN	MED	MAX
≤ 800 N/mm ²	S 1.1																								
≤ 1600 N/mm ²	S 1.2																								
40	50	60	0,04	0,04	0,05	0,06	0,07	0,08	0,09	0,11	0,13	0,11	0,14	0,16	0,13	0,16	0,19	0,18	0,22	0,25	0,22	0,27	0,32	0,32	
≤ 800 N/mm ²	S 2.1	30	40	50	0,04	0,04	0,05	0,06	0,07	0,08	0,09	0,11	0,13	0,11	0,14	0,16	0,13	0,16	0,19	0,18	0,22	0,25	0,22	0,27	0,32
≤ 1300 N/mm ²	S 2.2																								
		MIN	MED	MAX	MIN	MED	MAX	MIN	MED	MAX	MIN	MED	MAX	MIN	MED	MAX	MIN	MED	MAX	MIN	MED	MAX	MIN	MED	MAX
≤ 55 HRc	H 1.1																								
≤ 63 HRc	H 1.2																								
≤ 65 HRc	H 1.3																								

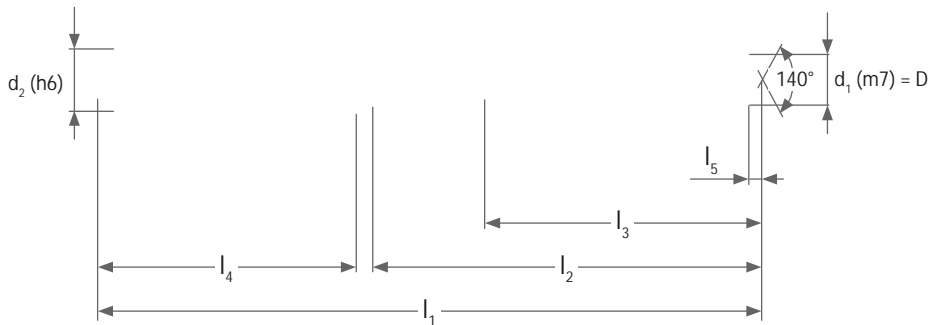

BOHRTIEFE · DRILL DEPTH · PROFONDEUR DE PERÇAGE · PROFONDITÀ DI FORATURA													5 x D							
OBERFLÄCHE · SURFACE · REVÊTEMENT · SUPERFICIE													TIBLU							
SCHNEIDSTOFF · MATERIAL · MATÉRIAU DE COUPE · MATERIALE													VHM							
ø d1 [mm]	GEWINDEBOHREN · TAPPING TARAUDS · MASCHI A MACCHINA							GEWINDEFORMEN · COLDFORMING TARAUDS À REFOULER · MASCHI A RULLARE						l ₁ [mm]	l ₂ [mm]	l ₃ [mm]	l ₄ [mm]	l ₅ [mm]	d ₂ [mm]	V #
	M	MF	MJ	UNC	UNF	UNJ	G	M	MF	MJ	UNC	UNF	G							
2,80							M3							61	22	17	36	0,6	6	D10005AA.0280
2,85				#6-32										61	22	17	36	0,6	6	D10005AA.0285
2,90	M3,5							M3x0,25						61	22	17	36	0,6	6	D10005AA.0290
2,95														61	22	17	36	0,6	6	D10005AA.0295
3,00		M3,5x0,5	MJ3,5x0,6			#6-40 UNJF								66	28	23	36	0,6	6	D10005AA.0300
3,10														66	28	23	36	0,6	6	D10005AA.0310
3,15		M3,5x0,35									#6-32			66	28	23	36	0,6	6	D10005AA.0315
3,20			MJ3,5x0,35											66	28	23	36	0,6	6	D10005AA.0320
3,22											#6-40			66	28	23	36	0,6	6	D10005AA.0322
3,25							M3,5							66	28	23	36	0,6	6	D10005AA.0325
3,30	M4							M3,5x0,5						66	28	23	36	0,7	6	D10005AA.0330
3,40			MJ4x0,7											66	28	23	36	0,7	6	D10005AA.0340
3,50		M4x0,5		#8-32	#8-36	#8-32 UNJC								66	28	23	36	0,7	6	D10005AA.0350
3,65		M4x0,35												66	28	23	36	0,7	6	D10005AA.0365
3,70	M4,5						M4		MJ4x0,7					66	28	23	36	0,7	6	D10005AA.0370
3,80								M4x0,5		#8-32				74	36	29	36	0,8	6	D10005AA.0380
3,90			MJ4,5x0,75	#10-24		#10-24 UNJC								74	36	29	36	0,8	6	D10005AA.0390
4,00		M4,5x0,5												74	36	29	36	0,8	6	D10005AA.0400
4,10			MJ4,5x0,5		#10-32									74	36	29	36	0,8	6	D10005AA.0410
4,20	M5	M5x0,75					M4,5							74	36	29	36	0,8	6	D10005AA.0420
4,30			MJ5x0,8					M4,5x0,5						74	36	29	36	0,8	6	D10005AA.0430
4,35										#10-24				74	36	29	36	0,8	6	D10005AA.0435
4,40														74	36	29	36	0,8	6	D10005AA.0440
4,45											#10-32			74	36	29	36	0,8	6	D10005AA.0445
4,50		M5x0,5		#12-24										74	36	29	36	0,9	6	D10005AA.0450
4,60	M5,5		MJ5x0,5		#12-28									74	36	29	36	0,9	6	D10005AA.0460
4,65							M5		MJ5x0,8					74	36	29	36	0,9	6	D10005AA.0465
4,70								M5x0,75						74	36	29	36	0,9	6	D10005AA.0470
4,80								M5x0,5						82	44	35	36	1,0	6	D10005AA.0480
4,90														82	44	35	36	1,0	6	D10005AA.0490
5,00	M6									#12-24				82	44	35	36	1,0	6	D10005AA.0500
5,10			MJ6x1	1/4-20			M5,5				#12-28			82	44	35	36	1,0	6	D10005AA.0510
5,20		M6x0,75												82	44	35	36	1,0	6	D10005AA.0520
5,25														82	44	35	36	1,0	6	D10005AA.0525
5,30								M5,5x0,5						82	44	35	36	1,1	6	D10005AA.0530
5,40														82	44	35	36	1,1	6	D10005AA.0540
5,50		M6x0,5			1/4-28									82	44	35	36	1,1	6	D10005AA.0550
5,55						1/4-28 UNJF				MJ6x1				82	44	35	36	1,1	6	D10005AA.0555
5,60			MJ6x0,5				M6							82	44	35	36	1,1	6	D10005AA.0560
5,70						5/16-18 UNJC		M6x0,75						82	44	35	36	1,1	6	D10005AA.0570
5,75										1/4-20				82	44	35	36	1,1	6	D10005AA.0575

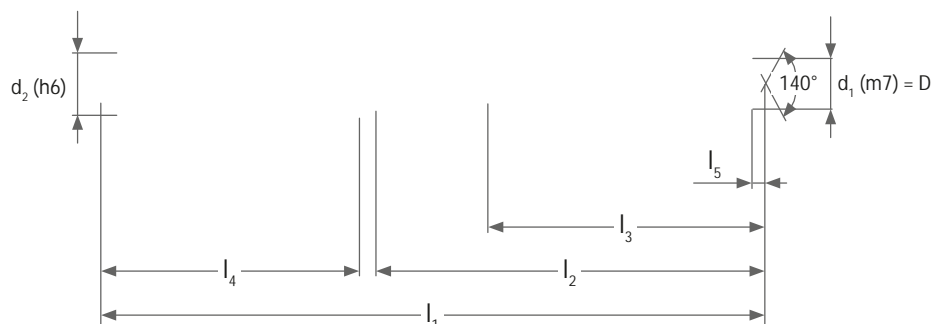

BOHRTIEFE · DRILL DEPTH · PROFONDEUR DE PERÇAGE · PROFONDITÀ DI FORATURA														5 x D							
OBERFLÄCHE · SURFACE · REVÊTEMENT · SUPERFICIE														TIBLU							
SCHNEIDSTOFF · MATERIAL · MATÉRIAU DE COUPE · MATERIALE														VHM							
ø d1 [mm]	GEWINDEBOHREN · TAPPING TARAUDS · MASCHI A MACCHINA							GEWINDEFORMEN · COLDFORMING TARAUDS À REFOULER · MASCHI A RULLARE							l ₁ [mm]	l ₂ [mm]	l ₃ [mm]	l ₄ [mm]	l ₅ [mm]	d ₂ [mm]	V #
	M	MF	MJ	UNC	UNF	UNJ	G	M	MF	MJ	UNC	UNF	G								
5,80								M6x0,5							82	44	35	36	1,2	6	D10005AA.0580
5,90															82	44	35	36	1,2	6	D10005AA.0590
5,95													1/4-28		82	44	35	36	1,2	6	D10005AA.0595
6,00	M7														82	44	35	36	1,2	6	D10005AA.0600
6,10															91	53	43	36	1,3	8	D10005AA.0610
6,20		M7x0,75													91	53	43	36	1,2	8	D10005AA.0620
6,30															91	53	43	36	1,3	8	D10005AA.0630
6,35			MJ7x0,75												91	53	43	36	1,3	8	D10005AA.0635
6,40															91	53	43	36	1,3	8	D10005AA.0640
6,50		M7x0,5													91	53	43	36	1,3	8	D10005AA.0650
6,60				5/16-18				M7							91	53	43	36	1,3	8	D10005AA.0660
6,70									M7x0,75						91	53	43	36	1,3	8	D10005AA.0670
6,80	M8						1/16		M7x0,5						91	53	43	36	1,4	8	D10005AA.0680
6,90			MJ8x1,25		5/16-24										91	53	43	36	1,4	8	D10005AA.0690
7,00		M8x1													91	53	43	36	1,4	8	D10005AA.0700
7,10			MJ8x1												91	53	43	36	1,4	8	D10005AA.0710
7,15															91	53	43	36	1,4	8	D10005AA.0715
7,20		M8x0,75													91	53	43	36	1,4	8	D10005AA.0720
7,25															91	53	43	36	1,4	8	D10005AA.0725
7,30													5/16-18		91	53	43	36	1,4	8	D10005AA.0730
7,40															91	53	43	36	1,5	8	D10005AA.0740
7,45								M8					5/16-24		91	53	49	36	1,5	8	D10005AA.0745
7,50		M8x0,5													91	53	49	36	1,5	8	D10005AA.0750
7,60									M8x1						91	53	49	36	1,5	8	D10005AA.0760
7,70									M8x0,75						91	53	49	36	1,5	8	D10005AA.0770
7,80	M9								M8x0,5						91	53	49	36	1,6	8	D10005AA.0780
7,90			MJ9x1,25												91	53	49	36	1,6	8	D10005AA.0790
8,00		M9x1		3/8-16											91	53	49	36	1,6	8	D10005AA.0800
8,10															103	61	49	40	1,7	10	D10005AA.0810
8,20		M9x0,75													103	61	49	40	1,6	10	D10005AA.0820
8,25															103	61	49	40	1,7	10	D10005AA.0825
8,30															103	61	49	40	1,7	10	D10005AA.0830
8,40															103	61	49	40	1,7	10	D10005AA.0840
8,50	M10	M9x0,5			3/8-24										103	61	49	40	1,7	10	D10005AA.0850
8,60			MJ10x1,5										M9x1		103	61	49	40	1,7	10	D10005AA.0860
8,70													M9x0,75		103	61	49	40	1,7	10	D10005AA.0870
8,80		M10x1,25						G1/8		M9x0,5			3/8-16		103	61	49	40	1,8	10	D10005AA.0880
8,90			MJ10x1,25												103	61	49	40	1,8	10	D10005AA.0890
9,00		M10x1													103	61	49	40	1,8	10	D10005AA.0900
9,05													3/8-24		103	61	49	40	1,8	10	D10005AA.0905
9,10			MJ10x1												103	61	49	40	1,8	10	D10005AA.0910

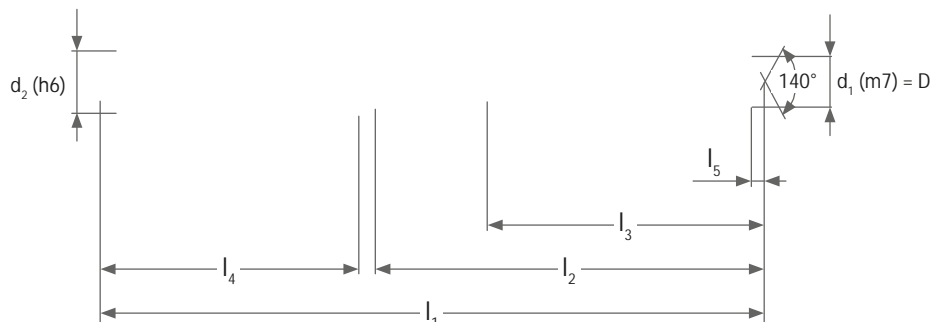

BOHRTIEFE · DRILL DEPTH · PROFONDEUR DE PERÇAGE · PROFONDITÀ DI FORATURA													5 x D							
OBERFLÄCHE · SURFACE · REVÊTEMENT · SUPERFICIE													TIBLU							
SCHNEIDSTOFF · MATERIAL · MATÉRIAU DE COUPE · MATERIALE													VHM							
ø d1 [mm]	GEWINDEBOHREN · TAPPING TARAUDS · MASCHI A MACCHINA						GEWINDEFORMEN · COLDFORMING TARAUDS À REFOULER · MASCHI A RULLARE						l ₁ [mm]	l ₂ [mm]	l ₃ [mm]	l ₄ [mm]	l ₅ [mm]	d ₂ [mm]	V #	
	M	MF	MJ	UNC	UNF	G	M	MF	MJ	UNC	UNF	G								
9,20		M10x0,75											103	61	49	40	1,8	10	D10005AA.0920	
9,25																			1/8	D10005AA.0925
9,30													103	61	49	40	1,9	10	D10005AA.0930	
9,35			MJ10x0,75				M10						103	61	49	40	1,9	10	D10005AA.0935	
9,40				7/16-14									103	61	49	40	1,9	10	D10005AA.0940	
9,45							M10x1,25						103	61	49	40	1,9	10	D10005AA.0945	
9,50	M11	M10x0,5											103	61	49	40	1,9	10	D10005AA.0950	
9,60			MJ10x0,5				M10x1						103	61	49	40	1,9	10	D10005AA.0960	
9,70							M10x0,75						103	61	49	40	1,9	10	D10005AA.0970	
9,80							M10x0,5						103	61	49	40	2,0	10	D10005AA.0980	
9,90			MJ11x1,25		7/16-20								103	61	49	40	2,0	10	D10005AA.0990	
10,00		M11x1											103	61	49	40	2,0	10	D10005AA.1000	
10,20	M12												118	71	56	45	2,0	12	D10005AA.1020	
10,25													118	71	56	45	2,0	12	D10005AA.1025	
10,30													118	71	56	45	2,1	12	D10005AA.1030	
10,40													118	71	56	45	2,1	12	D10005AA.1040	
10,50		M12x1,5											118	71	56	45	2,1	12	D10005AA.1050	
10,55																			7/16-20	D10005AA.1055
10,80		M12x1,25		1/2-13									118	71	56	45	2,2	12	D10005AA.1080	
11,00		M12x1											118	71	56	45	2,2	12	D10005AA.1100	
11,10			MJ12x1										118	71	56	45	2,2	12	D10005AA.1110	
11,20		M12x0,75											118	71	56	45	2,2	12	D10005AA.1120	
11,25		M12x0,75					M12						118	71	56	45	2,3	12	D10005AA.1125	
11,30													118	71	56	45	2,3	12	D10005AA.1130	
11,35							M12x1,5						118	71	56	45	2,3	12	D10005AA.1135	
11,50				1/2-20									118	71	56	45	2,3	12	D10005AA.1150	
11,60							M12x1						118	71	56	45	2,3	12	D10005AA.1160	
11,80													118	71	56	45	2,4	12	D10005AA.1180	
12,00	M14	M13x1											118	71	56	45	2,4	12	D10005AA.1200	
12,15																			1/2-20	D10005AA.1215
12,20				9/16-12									124	77	60	45	2,4	14	D10005AA.1220	
10,25		M11x0,75											118	71	56	45	2,0	12	D10005AA.1025	
12,50		M14x1,5											124	77	60	45	2,5	14	D10005AA.1250	
12,70							M13x0,75						124	77	60	45	2,5	14	D10005AA.1270	
12,80		M14x1,25											124	77	60	45	2,6	14	D10005AA.1280	
12,90			MJ14x1,25		9/16-18								124	77	60	45	2,6	14	D10005AA.1290	
13,00		M14x1											124	77	60	45	2,6	14	D10005AA.1300	
13,10			MJ14x1				M14						124	77	60	45	2,6	14	D10005AA.1310	
13,20		M14x0,75											124	77	60	45	2,6	14	D10005AA.1320	

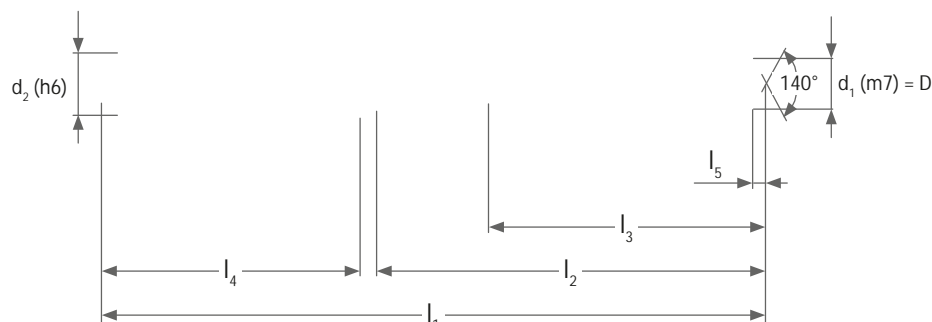
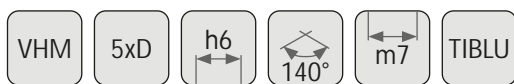

BOHRTIEFE · DRILL DEPTH · PROFONDEUR DE PERÇAGE · PROFONDITÀ DI FORATURA													5 x D						
OBERFLÄCHE · SURFACE · REVÊTEMENT · SUPERFICIE													TIBLU						
SCHNEIDSTOFF · MATERIAL · MATÉRIAU DE COUPE · MATERIALE													VHM						
ø d1 [mm]	GEWINDEBOHREN · TAPPING TARAUDS · MASCHI A MACCHINA						GEWINDEFORMEN · COLDFORMING TARAUDS À REFOULER · MASCHI A RULLARE						l ₁ [mm]	l ₂ [mm]	l ₃ [mm]	l ₄ [mm]	l ₅ [mm]	d ₂ [mm]	V #
	M	MF	MJ	UNC	UNF	G	M	MF	MJ	UNC	UNF	G							
13,30													124	77	60	45	2,7	14	D10005AA.1330
13,35								M14x1,5					124	77	60	45	2,7	14	D10005AA.1335
13,50				5/8-11									124	77	60	45	2,7	14	D10005AA.1350
13,95													124	77	60	45	2,7	14	D10005AA.1395
14,00	M16	M15x1											124	77	60	45	2,8	14	D10005AA.1400
14,20													133	83	63	48	2,9	16	D10005AA.1420
14,25													133	83	63	48	2,9	16	D10005AA.1425
14,50		M16x1,5		5/8-18									133	83	63	48	2,9	16	D10005AA.1450
14,75													133	83	63	48	3,0	16	D10005AA.1475
14,80									5/8-11				133	83	63	48	3,0	16	D10005AA.1480
14,90													133	83	63	48	3,0	16	D10005AA.1490
15,00		M16x1											133	83	63	48	3,0	16	D10005AA.1500
15,10			MJ16x1				M16						133	83	63	48	3,0	16	D10005AA.1510
15,25						3/8				5/8-18			133	83	63	48	3,1	16	D10005AA.1525
15,35								M16x1,5					133	83	63	48	3,1	16	D10005AA.1535
15,50	M18												133	83	63	48	3,1	16	D10005AA.1550
15,60								M16x1					133	83	63	48	3,2	16	D10005AA.1560
16,00		M18x2											133	83	63	48	3,2	16	D10005AA.1600
16,20													143	93	71	48	3,4	18	D10005AA.1620
16,25													143	93	71	48	3,4	18	D10005AA.1625
16,40													143	93	71	48	3,4	18	D10005AA.1640
16,50		M18x1,5		3/4-10									143	93	71	48	3,4	18	D10005AA.1650
16,75													143	93	71	48	3,4	18	D10005AA.1675
17,00		M18x1											143	93	71	48	3,4	18	D10005AA.1700
17,35													143	93	71	48	3,5	18	D10005AA.1735
17,50	M20			3/4-16									143	93	71	48	3,5	18	D10005AA.1750
17,80													143	93	71	48	3,5	18	D10005AA.1780
17,85									3/4-10				143	93	71	48	3,5	18	D10005AA.1785
18,20													153	101	77	50	3,7	20	D10005AA.1820
18,35										3/4-16			153	101	77	50	3,7	20	D10005AA.1835
18,50		M20x1,5											153	101	77	50	3,7	20	D10005AA.1850
18,85							M20						153	101	77	50	3,7	20	D10005AA.1885
19,00		M20x1											153	101	77	50	3,7	20	D10005AA.1900
19,15													153	101	77	50	3,8	20	D10005AA.1915
19,25													153	101	77	50	3,8	20	D10005AA.1925
19,35								M20x1,5					153	101	77	50	3,8	20	D10005AA.1935
19,50	M22			7/8-9									153	101	77	50	3,7	20	D10005AA.1950
19,75													153	101	77	50	3,9	20	D10005AA.1975
20,00													153	101	77	50	3,7	20	D10005AA.2000



DIN 6535 HA

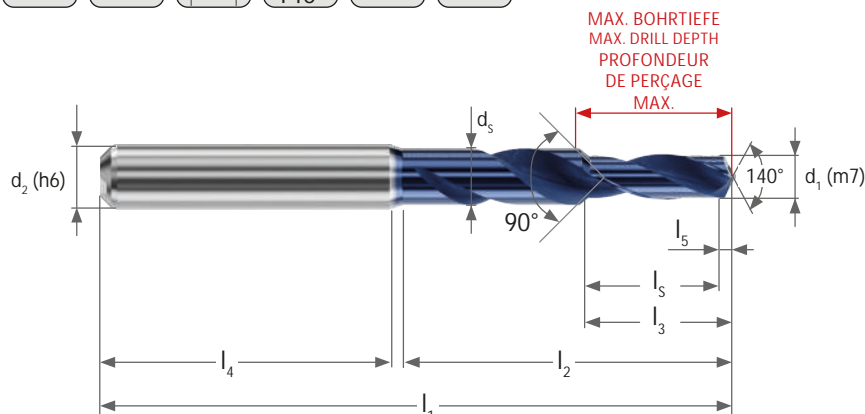

MAX. BOHRRTIEFE
MAX. DRILL DEPTH
PROFONDEUR
DE PERÇAGE
MAX.



BOHRRTIEFE · DRILL DEPTH · PROFONDEUR DE PERÇAGE · PROFONDITÀ DI FORATURA											3 x D*									
OBERFLÄCHE · SURFACE · REVÊTEMENT · SUPERFICIE											TIBLU									
SCHNEIDSTOFF · MATERIAL · MATÉRIAU DE COUPE · MATERIALE											VHM									
ø d1 [mm]	GEWINDEBOHREN · TAPPING TARAUDS · MASCHI A MACCHINA						GEWINDEFORMEN · COLDFORMING TARAUDS À REFOULER · MASCHI A RULLARE					l1	l2	l3	l4	l5	ls	d2	ds	V #
	M	MF	MJ	UNF	UNJ	G	M	MF	MJ	UNC	UNF									
2,80							M3					57	17	9,6	36	0,6	9	6	4	D20003AA.028009
2,90	M3,5							M3x0,25		#5-40		57	18	9,6	36	0,6	9	6	4	D20003AA.029009
3,25							M3,5					62	22	9,7	36	0,7	9	6	5	D20003AA.032509
3,30	M4							M3,5x0,5				62	24	11,7	36	0,7	11	6	5	D20003AA.033011
3,70	M4,5						M4		MJ4x0,7			62	24	11,8	36	0,8	11	6	5	D20003AA.037011
4,20	M5	M5x0,75					M4,5					66	29	14,9	36	0,9	14	6	6	D20003AA.042014
4,65							M5		MJ5x0,8			66	29	14,9	36	0,9	14	6	6	D20003AA.046514
5,00	M6									#12-24		79	40	18,0	36	1,0	17	8	7	D20003AA.050017
5,60			MJ6x0,5				M6					79	40	18,1	36	1,1	17	8	7	D20003AA.056017
6,00	M7											79	42	22,2	36	1,2	21	8	8	D20003AA.060021
6,80	M8					1/16		M7x0,5				89	46	22,4	40	1,4	21	10	9	D20003AA.068021
7,00		M8x1			UNJF 5/16-24							89	46	22,4	40	1,4	21	10	9	D20003AA.070021
7,45							M8			5/16-24		89	46	22,5	40	1,5	21	10	9	D20003AA.074521
7,60								M8x1				89	46	22,5	40	1,5	21	10	9	D20003AA.076021
7,80	M9							M8x0,5				89	48	27,5	40	1,5	26	10	10	D20003AA.078022
8,45								M9				89	56	27,7	40	1,7	26	12	10	D20003AA.084522
8,50	M10	M9x0,5			3/8-24							102	56	27,7	45	1,7	26	12	11	D20003AA.085026
9,00		M10x1										102	56	27,8	45	1,8	26	12	11	D20003AA.090026
9,35			MJ10x0,75				M10					102	56	27,8	45	1,8	26	12	11	D20003AA.093526
9,60			MJ10x0,5					M10x1				102	56	23,9	45	1,9	22	12	12	D20003AA.096022
10,20	M12	M11x0,75										107	61	32,0	45	2,0	30	14	14	D20003AA.102030
10,35							M11					107	61	32,0	45	2,0	30	14	14	D20003AA.103530
10,50		M12x1,5										107	61	32,1	45	2,1	30	14	14	D20003AA.105030
11,25		M12x0,75					M12					107	61	32,2	48	2,2	30	14	14	D20003AA.112530
11,35								M12x1,5				107	61	32,2	48	2,2	30	14	14	D20003AA.113530
12,00	M14	M13x1										115	66	39,4	48	2,4	37	16	15	D20003AA.120037
12,50		M14x1,5										115	66	39,4	48	2,4	37	16	15	D20003AA.125037
13,10			MJ14x1				M14					115	66	39,6	48	2,6	37	16	15	D20003AA.131037
13,35								M14x1,5				115	66	39,6	48	2,6	37	16	15	D20003AA.133537
14,00	M16	M15x1										123	74	44,7	48	2,7	42	18	18	D20003AA.140042
14,50		M16x1,5			5/8-18							123	74	44,8	48	2,8	42	18	18	D20003AA.145042
15,10			MJ16x1				M16					123	74	44,9	48	2,9	42	18	18	D20003AA.151042
15,35								M16x1,5				123	74	45,0	48	3,0	42	18	18	D20003AA.153542
15,50	M18											131	80	48,0	50	3,0	45	20	20	D20003AA.155045

* DE (" =ku@7- Vuohk-#=-V# ' (Vyu-" k-k-8-† () -u@7- † -@-k- " =ku@7-V' U U ouy7yV8 " y7" V7k' 8- @e7-k" k
EN () k@8) -hu=#\kk-oh\ V) u\ " hkh\ (E (y o" O u-k-)) -hu= 7yku=-k) k@8) -hu=o' U U ou-ho " f' @ " O \ V k-j y-ou
FR O hk\ \ V) -yk) -h-k(' 8- (#\kk-oh\ V) " yV- hk\ \ V) -yk) -7@ú 8-) - () @7/k-Vu-ohk\ \ V) -yko) -h-k(' 8- " y h' o) -) @h\ V@Oooyk) -U" V) -'
IT ' hk\ \ V) @') @\k' uyk' (#\kk-oh\ V) - " hkh\ oo@' u@' U-Vu- " yV' hk\ \ V) @') -O7@u\ ((y@-k@k@h\ \ V) @') @\k' uyk' h' oo@ U U ol\ V) @h\ V@Ooy k@=#=o'ur



SOLUTIONS@NORIS-REIME.DE

Das REIME Team steht Ihnen bei der Lösung Ihrer Zerspanungsaufgabe gerne zur Seite

The REIME team will be happy to solve your threading tasks

L'équipe de REIME se tient à votre disposition pour résoudre vos problèmes de filetage

Il team REIME sarà lieto di risolvere i vostri problemi di filettatura

UNSERE PRÄZISION IST IHR ERFOLG
OUR PRECISION IS YOUR SUCCESS

SCHNEIDEISEN

Dies
Filières
Filiere





AUSWAHLÜBERSICHT

) @ " V8-8- " -V-V'o#=#V@u8-o#=#† @) @M@-V'†#`@'U U @
o@) k@=#u† -ku- yV) U -oo-V) -V`@) @@y-@-V
ARBEITSBEDINGUNGEN ANGEPAST WERDEN.



GUIDE DE SELECTION

O o'†°O-yko) -†@-oo-) -#`yh-†#'-V'U U @ `@) @y/-o) °VoO-o
#\O.VV-o'k-oh-#u@-oV-'o\Vu'j y @) @°u@-o-'u)\@-Vu'Ok-
'°)°hu/-o@) @@y-@-U-Vu°y@#\V) @@Vo) yo@°8-



oy U U ° k' ` \ 7° oo\ kuU - Vu

u=-'O@u-) #yuu@8'oh--) o'†#`@'U U @ `°k-'ou'V) °k) †°Oy-o
u=@†°Oy-o='†-'u\ " -") Kyou-) 'u\ @) @@y°O† \kM#\V) @@Vo



SCelta DEGLI UTENSILI

@°°k@ @-O #@°) @'8O@'†#`@'U U @ 'j y@-O-V#°u@V\
hyk°U-Vu- @) @°u@-) -†\V\°-oo-k-'°) °uu°@-@-#\V) @@V@
) @h@8\



	STAHlWERKSTOFFE	ou- -OU ° u- k@Q	ACIERS	ACCAI
P	Un- und niedriglegierte Stähle	Unalloyed and low-alloy steels	Aciers non et faiblement alliés	
	Hochlegierte Stähle	High alloy steels	Aciers hautement alliés	
U	ROSTFREI STÄHLE	CORROSION AND ACID PROOF STEELS	° #°k@`@`@k-@u° #@-o	° ##@`@`@k-@u-Vu@8O@ #@@
	k)yhO@	Corrosion and acid proof steels)yhO@)yhO@)yhO@
K	GUSSWERKSTOFFE	#° ou'U ° u- k@Q	FONTES	GHISE
	Grauguss, Kugelgraphitguss, † u 8	Cast iron, nodular cast iron, † u 8	Fonte grise, fonte à graphite sphéroïdal, Fonte à graphite vermiculaire, Fonte malléable 7	Ghisa grigia, ghisa nodulare, 8 8
N	V@=#u-@-V † -kMu\ 77-	V\ V 7-kk\yoU ° u- k@Q	U ° u/k@y@V\ V 7-kk-y@	U ° u-k@Q\ V 7-kk\o@
	Aluminium-Knetlegierungen	Aluminium wrought alloys		Leghe malleabili di alluminio
	Aluminium-Gusslegierungen	Aluminium cast alloys	Fontes d'alu	Leghe fuse di alluminio
	M M	# #	#	k O
	M	#		O
	Kupferlegierungen hochfest	High-strength copper alloys	Alliages cuivre haute résistance	O
	- O	-		O
U O	U	Alliages de magnésium corroyés	Leghe malleabili di magnesio	
Thermoplaste	u	u	k	
7 M)	7)	h	k h	
S	ch-@-@-kMu\ 77-	ch-#@OU ° u- k@Q	U ° u/k@y@h/#@y@	U ° u-k@Qch-#@@
	Ni-, Fe- oder Co- Basis- Superlegierungen	Ni-, Fe- or Co- base- Superalloys	Base Ni, Fe ou Co- Superalliages	A base Ni-, Fe- o Co- Superleghe
	Titan + Titanlegierungen	Titanium + Titanium alloys	u	u O
H	GEHÄRTETE WERKSTOFFE	HARDENED STEELS	° #°k@uk° @/o	° ##@-U hk° u@
	Gehärtete Stähle	Hardened steels	Aciers traités	



	NORIS SE			NORIS GLOCKEN SE	
	ST	VA	MS	ST	MS
	HSS	GEL HSS	HSSE	GEL HSSE	GEL HSS
M	170	170	171	171	171
MF	172	172	172		
UNC	173	173			
UNF UNEF	174	174			
G	175	175			175
BSW BSF	176				
NPT NPTF	177				
R	178				

		Vc m/min.				Vc m/min.	
...	V	P 1.1	1-8	1-8	1-8	1-8	1-8
...	V	P 1.2					
...	V	P 1.3					
...	V	P 2.1					
		Vc m/min.				Vc m/min.	
...	V	U		1-4	1-4		
...	V	U					
		Vc m/min.				Vc m/min.	
...	V	K 1.1					
...	V	K 2.1					
		Vc m/min.				Vc m/min.	
		N 1.1		10-20			
	o	N 1.2					
	o	N 1.3					
		N 2.1		10-20			
		N 2.2			10-25		10-25
...	V	N 2.3					
		N 3.1					
		N 4.1					
		N 5.1	6-8	6-8	6-8	6-8	6-8
		N 5.2		8-10	8-10		
		Vc m/min.				Vc m/min.	
...	V	S 1.1					
...	V	S 1.2					
...	V	S 2.1					
...	V	S 2.2					
		Vc m/min.				Vc m/min.	
...	=k	H 1.1					
...	=k	H 1.2					
...	=k	H 1.3					

- U y C a V / U y C a V |
 o# = V - @ a O # y u u @ 8 \ @ = y @) - # \ y h - \ C a) * ' u ' 8 O a |
 u k \ # M V ') k' o. # = - ' ' o - # \

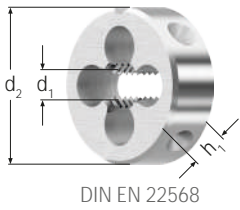

DIN EN 22568				HSS			HSS
DIN EN 22568				1,5			1
d ₁	P	h ₁	d ₂	6g	6g - LH	6e	6g
M 1	0,25	5	16	2020AAAA			2030A1821
M 1,2	0,25	5	16	2020AACAA			2030AACAA
M 1,4	0,3	5	16	2020AADAA			2030AADAA
M 1,6	0,35	5	16	2020AAEAA			2030AAEAA
M 1,8	0,35	5	16	2020AAGAA			
M 2	0,4	5/8	16	2020AAHAA	2020AA4AA		2030AAHAA
M 2,2	0,45	5	16	2020AAIAA			2030AAIAA
M 2,3	0,45	5	16	2020AAJAA			2030AAJAA
M 2,5	0,45	5/8	16	2020ABSAA			2030AAKAA
M 3	0,5	5/8	20	2020ABUAA	2020AA9AA	2020AAQAA	2030AAMAA
M 3,5	0,6	5	20	2020ABVAA			2030AANAA
M 4	0,7	5/9,5	20	2020ABWAA	2020ABBAA	2020AASAA	2030AAPAA
M 5	0,8	7/9,5	20	2020ABYAA	2020ABCAA	2020AATAA	2030AARAA
M 6	1	7/9,5	20	2020ABZAA	2020ABDAA	2020AAUAA	2030AASAA
M 8	1,25	9	25	2020AB1AA	2020ABEAA	2020AAVAA	2030AAUAA
M 9	1,25	9	25	2020AB2AA			2030AAVAA
M 10	1,5	11	30	2020AB3AA	2020ABFAA	2020AAWAA	2030AAWAA
M 11	1,5	11	30	2020AB4AA			2030A1037
M 12	1,75	14	38	2020AB5AA	2020ABGAA	***E*	*****
M 14	2	14	38	2020AB6AA	2020ABHAA		2030AAZAA
M 16	2	18	45	2020AB7AA	2020ABIAA		2030AA0AA
M 18	2,5	18	45	2020AB8AA			2030AA1AA
M 20	2,5	18	45	2020AB9AA	2020ABKAA		2030AA2AA
M 22	2,5	22	55	2020ACAAA			2030AA3AA
M 24	3	22	55	2020ACBAA	2020ABMAA		2030AA4AA
M 27	3	25	65				
M 30	3,5	25	65	2020ACDAA			2030A1038



HSSE		HSS		t\k`k"-@o)yk#=U-oo-k` hk-h`k`u\k`)@U-u-k)@U.uk-)-O-`y#=-)@U-uk\`)@hk-h`k`-@V-	
2		1			
6g	6g	6g	d ₁	P	6e 6g
			M 1	0,25	0,93 0,97
			M 1,2	0,25	1,13 1,17
			M 1,4	0,3	1,32 1,36
			M 1,6	0,35	1,51 1,54
			M 1,8	0,35	1,71 1,74
2045AAAAA	2055AAAAA	2080AAAAA	M 2	0,4	1,90 1,93
			M 2,2	0,45	2,10 2,13
			M 2,3	0,45	2,20 2,23
2045AADAA	2055A1156	2080AACAA	M 2,5	0,45	2,40 2,43
2045AAFAA	2055AAFAA	2080AAEAA	M 3	0,5	2,89 2,92
2045AAGAA	2055A1157	2080AAFAA	M 3,5	0,6	3,38 3,41
2045AAHAA	2055AAHAA	2080AAGAA	M 4	0,7	3,87 3,9
2045AAIAA	2055AAIAA	2080AAHAA	M 5	0,8	4,86 4,9
2045AAJAA	2055AAJAA	2080AAIAA	M 6	1	5,85 5,88
2045AAKAA	2055AAKAA	2080AAJAA	M 8	1,25	7,83 7,86
			M 9	1,25	8,83 8,86
2045AALAA	2055AALAA	2080AAKAA	M 10	1,5	9,81 9,85
			M 11	1,5	10,81 10,85
U`U`U`	U`U`U`	2080AALAA	M 12	1,75	11,81 11,83
2045AANAA	2055AANAA		M 14	2	13,78 13,82
2045AAPAA	2055AAPAA		M 16	2	15,78 15,82
2045AAQAA	2055AAQAA		M 18	2,5	17,75 17,79
2045AARAA	2055AARAA		M 20	2,5	19,75 19,79
2045AASAA	2055A1152		M 22	2,5	21,75 21,79
2045AATAA	2055A1153		M 24	3	23,72 23,76
2045AAUAA	2055A1154		M 27	3	26,72 26,76
2045AAVAA	2055A1155		M 30	3,5	29,70 29,73

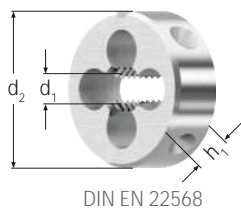

DIN EN 22568

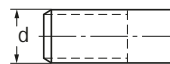

O# = V - Ø ou 77 U' u - k @ O U' u @ k - U' u - k @ O V o # = V @ u 7 k U ' # = U 7 - k 7 k U 7 k U -) - V u k / - 7 k U ') @ " \ # # \					HSS		HSSE	HSS	† \ k' k' - @ o y k # = U - oo - k' h k - h' k' u k') @ U - u - k') @ U . uk -) - O - " y # = -) @ U - uk \) @ h k - h' k' - @ V -	
d ₁	x	P	h ₁	d ₂	6g	6g - LH	6g	6g	6g	6g
MF 2,5	x	0,35	5	16	2020ACPAA		2030ABHAA			2,44
MF 3	x	0,35	5	20			2030ABJAA			2,94
MF 3,5	x	0,35	5	20	2020ACSAA		2030ABKAA			3,44
MF 4	x	0,35	5	20	2020ACTAA		2030A1043			3,94
MF 4	x	0,5	5	20	2020ACUAA	2020AFAAA				3,92
MF 5	x	0,5	5	20	2020ACVAA	2020AFBAA	2030A1044			4,92
MF 6	x	0,5	5	20	2020ACWAA	2020AFCAA	2030A1045		2080AA8AA	5,92
MF 6	x	0,75	7	20	2020ACXAA	2020AFDAA	2030ABQAA	2045AA2AA	2080AA9AA	5,90
MF 7	x	0,75	9	25	2020ACYAA		2030A1046		2080A1165	6,90
MF 8	x	0,5	9	25	2020ACZAA		2030A1047			7,92
MF 8	x	0,75	9	25	2020AC0AA	2020AFEAA	2030A1048	2045AA3AA	2080ABAAA	7,90
MF 8	x	1	9	25	2020AC1AA	2020AFFAA	2030ABUAA	2045AA4AA	2080ABBAA	7,88
MF 9	x	0,75	9	25	2020AC2AA		2030ABVAA			8,90
MF 9	x	1	9	25	2020AC3AA		2030A1049			8,88
MF 10	x	0,75	11	30	2020AC5AA		2030ABYAA		2080A1168	9,90
MF 10	x	1	11	30	2020AC6AA	2020AFGAA		2045AA5AA	2080ABCAA	9,88
MF 10	x	1,25	11	30	2020AC7AA		2030AB0AA			9,86
MF 11	x	1	11	30	2020AC8AA		2030AB1AA			10,88
MF 12	x	1	10	38	2020ADAAA	2020AFHAA	2030A1051	2045AA6AA	2080ABDAA	11,88
MF 12	x	1,25	10	38	2020ADBAA		2030A1052			11,86
MF 12	x	1,5	10	38	2020ADCAA	2020AFIAA	2030AB5AA	2045AA7AA		11,85
MF 13	x	1	10	38	2020ADDAA		2030A1053			12,88
MF 14	x	1	10	38	2020ADGAA	2020AFJAA	2030A1054		2080ABFAA	13,88
MF 14	x	1,25	10	38	2020ADHAA		2030ACAAA			13,86
MF 14	x	1,5	10	38	2020ADIAA	2020AFKAA	2030A1055	2045AA8AA	2080ABGAA	13,85
MF 15	x	1	10	38	2020ADJAA		2030A1056			14,88
MF 15	x	1,5	10	38	2020ADKAA		2030ACDAA			14,85
MF 16	x	1	14	45	2020ADLAA		2030A1057		2080A1169	15,88
MF 16	x	1,5	14	45	2020ADMAA	2020AFLAA	2030A1058	2045AA9AA	2080ABHAA	15,85
MF 18	x	1	14	45	2020ADNAA		2030ACGAA			17,88
MF 18	x	1,5	14	45	2020ADPAA	2020AFMAA	2030ACHAA	2045ABAAA	2080ABIAA	17,85
MF 18	x	2	14	45	2020ADQAA		2030A1059			17,82
MF 20	x	1	14	45	2020ADRAA		2030ACJAA			19,88
MF 20	x	1,5	14	45	2020ADSAA	2020AFNAA	2030ACKAA	2045ABBAA	2080ABJAA	19,85
MF 20	x	2	14	45	2020ADTAA		2030A1060			19,82
MF 22	x	1	16	55	2020ADUAA		2030ACMAA		2080A1171	21,88
MF 22	x	1,5	16	55	2020ADVAA	2020AFPAA	2030A1061	2045ABCAA	2080ABKAA	21,85
MF 22	x	2	16	55	2020ADWAA		2030A1062			21,82
MF 24	x	1	16	55	2020ADXAA		2030A1063			23,88
MF 24	x	1,5	16	55	2020ADYAA	2020AFQAA	2030A1064	2045ABDAA	2080ABLAA	23,85
MF 24	x	2	16	55			2030A1065			23,82
MF 25	x	1	16	55			2030A1066			24,88
MF 25	x	1,5	16	55	2020AD1AA		2030A1067			24,85
MF 26	x	1,5	16	55	2020AD2AA		2030A1068			25,85
MF 27	x	1	18	65	2020AD3AA		2030A1069			26,88
MF 27	x	1,5	18	65	2020AD4AA		2030A1070			26,85
MF 27	x	2	18	65	2020AD5AA		2030A1071			26,82
MF 28	x	1	18	65			2030A1072			27,88
MF 28	x	1,5	18	65	2020AD6AA		2030AC0AA			27,85
MF 30	x	1	18	65	2020AD8AA		2030A1073			29,88
MF 30	x	1,5	18	65	2020AD9AA		2030A1074			29,85
MF 30	x	2	18	65	2020AEAAA		2030A1075			29,82

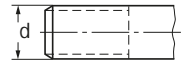
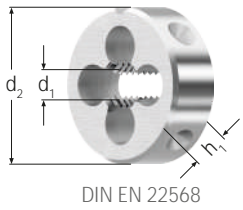

o#=V-@ou\ 77' U'u-k@O U'u@k-'U'u-k@O				HSS		t\k"-(@)yk#=U-oo-k" hk-h'u\k')@U-u-k)@U.uk-)-O-"y#=-)@U-uk\)@hk-h'k'-@V-	
*Vo#=V@u\kU""#="U7-k\kU kU-)-Vuk/-\kU") @ "\##\				1,5			
d ₁	- h	h ₁	d ₂	2A	2A	2A	
UNC Nr. 1	- 64	5	16	2020AFSAA	2030AD2AA	1,79	
UNC Nr. 2	- 56	5	16	2020AFTAA	2030AD3AA	2,12	
UNC Nr. 3	- 48	5	16	2020AFUAA	2030AD4AA	2,44	
UNC Nr. 4	- 40	5	16	2020AFVAA	2030A1094	2,76	
UNC Nr. 5	- 40	5	20	2020AFWAA	2030AD6AA	3,09	
UNC Nr. 6	- 32	7	20	2020AFXAA	2030A1095	3,41	
UNC Nr. 8	- 32	7	20	2020AFYAA	2030AD8AA	4,07	
UNC Nr. 10	- 24	7	20	2020AFZAA	2030A1096	4,71	
UNC Nr. 12	- 24	7	20	2020AF0AA	2030AEAAA	5,37	
UNC 1/4	- 20	7	20	2020AF1AA	2030AEBAA	6,22	
UNC 5/16	- 18	9	25	2020AF2AA	2030A1097	7,80	
UNC 3/8	- 16	11	30	2020AF3AA	2030A1098	9,37	
UNC 7/16	- 14	11	30	2020AF4AA	2030A1099	10,95	
UNC 1/2	- 13	14	38	2020AF5AA	2030A1100	12,52	
UNC 9/16	- 12	14	38	2020AF6AA	2030AEGAA	14,10	
UNC 5/8	- 11	18	45	2020AF7AA	2030AEHAA	15,68	
UNC 3/4	- 10	18	45	2020AF8AA	2030AEIAA	18,84	
UNC 7/8	- 9	22	55	2020AF9AA	2030AEJAA	22,00	
UNC 1	- 8	22	55	2020AGAAA	2030A1101	25,16	
UNC 1 1/8	- 7	25	65	2020AGBAA	2030A1102	28,31	
UNC 1 1/4	- 7	25	65	2020AGCAA	2030A1103	31,49	
UNC 1 3/8	- 6	25	65	2020AGDAA	2030AENAA	34,63	
UNC 1 1/2	- 6	30	75	2020AGEAA	2030AEPAA	37,80	
UNC 1 3/4	- 5	36	90	2020A1003	2030A1104	44,12	
UNC 2	- 4,5	36	90	2020A1004	2030AERAA	50,45	

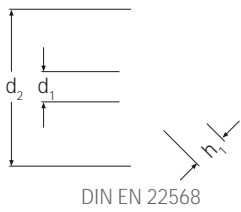

d_1 - h h_1 d_2				HSS		d
				1,5		
				2A	2A	2A
UNF Nr. 0	- 80	5	16	2020AGHAA	2030AESAA	1,47
UNF Nr. 1	- 72	5	16	2020AGIAA	2030AETAA	1,8
UNF Nr. 2	- 64	5	16	2020AGJAA	2030AEUAA	2,12
UNF Nr. 3	- 56	5	16	2020AGKAA	2030AEVAA	2,44
UNF Nr. 4	- 48	5	16	2020AGLAA	2030A1105	2,77
UNF Nr. 5	- 44	5	20	2020AGMAA	2030AEXAA	3,1
UNF Nr. 6	- 40	5	20	2020AGNAA	2030AEYAA	3,42
UNF Nr. 8	- 36	7	20	2020AGPAA	2030AEZAA	4,08
UNF Nr. 10	- 32	7	20	2020AGQAA	2030AEOAA	4,73
UNF Nr. 12	- 28	7	20	2020AGRAA	2030AE1AA	5,38
UNF 1/4	- 28	7	20	2020AGSAA	2030AE2AA	6,24
UNF 5/16	- 24	9	25	2020AGTAA	2030A1106	7,82
UNF 3/8	- 24	11	30	2020AGUAA	2030A1107	9,41
UNF 7/16	- 20	11	30	2020AGVAA	2030A1108	10,98
UNF 1/2	- 20	10	38	2020AGWAA	2030A1109	12,56
UNF 9/16	- 18	10	38	2020AGXAA	2030A1110	14,14
UNF 5/8	- 18	14	45	2020AGYAA	2030A1111	15,73
UNF 3/4	- 16	14	45	2020AGZAA	2030A1112	18,89
UNF 7/8	- 14	16	55	2020AG0AA	2030A1113	22,05
UNF 1	- 12	16	55	2020AG1AA	2030A1114	25,21
UNF 1 1/8	- 12	18	65	2020AG2AA	2030A1115	28,38
UNF 1 1/4	- 12	18	65	2020AG3AA	2030A1116	31,55
UNF 1 3/8	- 12	18	65	2020AG4AA	2030AFEAA	34,73
UNF 1 1/2	- 12	20	75	2020AG5AA	2030A1117	37,9
UNEF Nr. 12	- 32	7	20	2020AQYAA	2030A1118	5,39
UNEF 1/4	- 32	7	20	2020AQZAA	2030A1119	6,25
UNEF 5/16	- 32	9	25	2020AQ0AA	2030A1120	7,84
UNEF 3/8	- 32	11	30	2020AQ1AA	2030A1121	9,42
UNEF 7/16	- 28	11	30	2020AQ2AA	2030A1122	11
UNEF 1/2	- 28	10	38	2020AQ3AA	2030A1123	12,59
UNEF 9/16	- 24	10	38	2020AQ4AA	2030A1124	14,17
UNEF 5/8	- 24	14	45	2020AQ5AA	2030A1125	15,75
UNEF 3/4	- 20	14	45	2020AQ7AA	2030A1126	18,91
UNEF 7/8	- 20	16	55	2020AQ8AA	2030A1127	22,09
UNEF 1	- 20	16	55	2020ARBAA	2030A1128	25,26

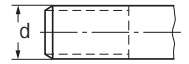
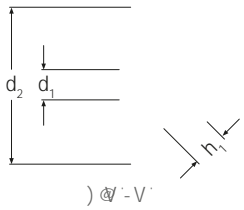

d_1 - h h_1 d_2				HSS		HSS		$t \setminus k \setminus k \setminus - @ o y k \setminus = U - oo - k \setminus \setminus$ $hk - h \setminus k \setminus u \setminus k \setminus) @ U - u - k \setminus \setminus$ $) @ U . uk -) - O - \setminus y \setminus = -$ $) @ U - uk \setminus) @ hk - h \setminus k \setminus - @ V -$	
d_1 - h h_1 d_2				1,5		1		Class A	
d_1 - h h_1 d_2				Class A		Class A		Class A	
G 1/16	- 28	9	25						7,62
G 1/8	- 28	11	30	2020AHVAA	2030AF5AA	2080AAPAA			9,62
G 1/4	- 19	10	38	2020AHWAA	2030AF6AA	2080AAQAA			13,03
G 3/8	- 19	14	45	2020AHXAA	2030AF7AA	2080AARAA	2280A1829		16,54
		20	38				2280A1830		
G 1/2	- 14	14	45	2020AHYAA	2030AF8AA	2080AASAA			20,81
		24	45				2280A1831		
G 5/8	- 14	16	55	2020AHZAA	2030A1077				22,77
G 3/4	- 14	16	55	2020AH0AA	2030AGAAA	2080AAUAA			26,3
		28	55				2280A1833		
G 7/8	- 14	18	65	2020AH1AA	2030A1078				30,06
		30	65				2080AAWAA		
G 1	- 11	18	65	2020AH2AA	2030AGCAA				33,07
		30	65				2280A1834		
G 1 1/8	- 11	20	75	2020AH3AA	2030A1079				37,72
G 1 1/4	- 11	20	75	2020AH4AA	2030A1080	2080A1174			41,73
G 1 3/8	- 11	22	90	2020AH5AA	2030A1081				44,14
G 1 1/2	- 11	22	90	2020AH6AA	2030A1082	2080A1175			47,62
		22	90						
G 1 3/4	- 11	22	90	2020AH7AA	2030AGHAA				53,57
G 2	- 11	22	105	2020AH8AA	2030A1083				59,43

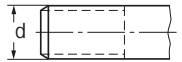
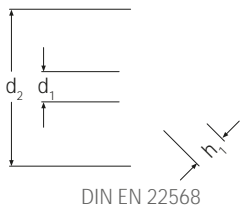

d_1 - P/1" h_1 d_2				HSS	d
d_1 - P/1" h_1 d_2				1,5	MED
d_1 - P/1" h_1 d_2				MED	MED
BSW 1/16	- 60	5	16	2020AG6AA	1,51
BSW 3/32	- 48	5	16	2020AG7AA	2,3
BSW 1/8	- 40	5	20	2020AG8AA	3,09
BSW 5/32	- 32	7	20	2020AG9AA	3,88
BSW 3/16	- 24	7	20	2020AHAAA	4,66
BSW 7/32	- 24	7	20	2020AHBAA	5,46
BSW 1/4	- 20	7	20	2020AHCAA	6,24
BSW 5/16	- 18	9	25	2020AHDAA	7,82
BSW 3/8	- 16	11	30	2020AHEAA	9,4
BSW 7/16	- 14	11	30	2020AHFAA	10,98
BSW 1/2	- 12	10	38	2020AHGAA	12,56
BSW 9/16	- 12	14	38	2020AHHAA	14,14
BSW 5/8	- 11	14	45	2020AHIAA	15,72
BSW 3/4	- 10	14	45	2020AHJAA	18,89
BSW 7/8	- 9	16	55	2020AHKAA	22,1
BSW 1	- 8	22	55	2020AHLAA	25,27
BSW 1 1/8	- 7	25	65	2020AHNAA	28,44
BSW 1 1/4	- 7	25	65	2020AHPAA	31,61
BSW 1 3/8	- 6	25	65	2020AHQAA	34,77
BSW 1 1/2	- 6	30	75	2020A1000	37,95
BSW 1 5/8	- 5	30	75	2020A1001	41,11
BSW 1 3/4	- 5	36	90	2020A1002	44,28
BSW 2	- 4,5	36	90	MED	50,63
BSF 3/16	- 32	7	20	2020AJEAA	4,67
BSF 1/4	- 26	7	20	2020AJFAA	6,25
BSF 5/16	- 22	9	25	2020AJGAA	7,83
BSF 3/8	- 20	11	30	2020AJHAA	9,41
BSF 7/16	- 18	11	30	2020AJIAA	10,99
BSF 1/2	- 16	14	38	2020AJJAA	12,57
BSF 5/8	- 14	18	45	2020AJKAA	15,73
BSF 3/4	- 12	18	45	2020AJLAA	18,89
BSF 7/8	- 11	22	55	2020AJMAA	22,11
BSF 1	- 10	22	55	2020AJNAA	25,28

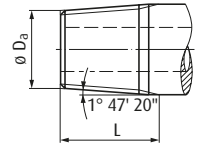
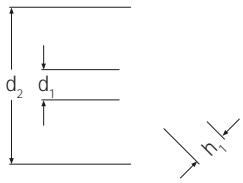

d_1 - P/1" h_1 d_2				HSS	ϕDa min. ϕDa max. $\approx L$		
NPT 1/16	- 27		25	2020AIUAA	7,52	7,64	8,3
NPT 1/8	- 27	11	30	2020AIVAA	9,87	9,99	8,4
NPT 1/4	- 18	14	38	2020AIWAA	13,10	13,26	12,7
NPT 3/8	- 18	14	45	2020AIXAA	16,52	16,67	12,9
NPT 1/2	- 14	18	45	2020AIYAA	20,55	20,71	16,8
NPT 3/4	- 14	22	55	2020AIZAA	25,87	26,03	17,0
NPT 1	-	25	65	2020AI0AA	32,42	32,59	21,2
NPT 1 1/4	-	26	75	2020AI1AA	41,14	41,32	21,9
NPT 1 1/2	-	27	90	2020AI2AA	47,21	47,39	22,3
NPT 2	-	28	105	2020AI3AA	59,25	59,42	23,1
NPTF 1/16	- 27		25	2020AI4AA	7,52	7,62	9,2
NPTF 1/8	- 27	11	30	2020AI5AA	9,87	9,96	9,3
NPTF 1/4	- 18	14	38	2020AI6AA	13,13	13,21	14,1
NPTF 3/8	- 18	14	45	2020AI7AA	16,55	16,63	14,3
NPTF 1/2	- 14	18	45	2020AI8AA	20,62	20,70	18,6
NPTF 3/4	- 14	22	55	2020AI9AA	25,93	26,02	18,9
NPTF 1	-	25	65	2020AJAAA	32,47	32,56	23,5
NPTF 1 1/2	-	27	90	2020AJCAA	47,27	47,36	24,5

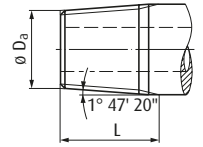
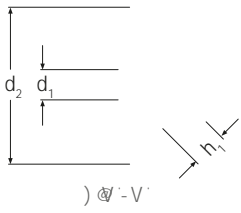

d_1 - P/1" h_1 d_2		$\varnothing D_a$	Tol.	$\approx L$
R 1/8 - 28 11 30	2020AIBAA	9,48	$\pm 0,05$	8,1
R 1/4 - 19 14 38	2020AICAA	12,78	$\pm 0,08$	12
R 3/8 - 19 14 45	2020AIDAA	16,26	$\pm 0,08$	12,4
R 1/2 - 14 18 45	2020AIEAA	20,44	$\pm 0,11$	16,4
R 3/4 - 14 22 55	2020AIFAA	25,85	$\pm 0,11$	17,7
R 1 - 11 25 65	2020AIGAA	32,60	$\pm 0,14$	20,8

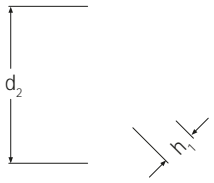

Nr.	$\varnothing d_2 \times h_1$	
0	16 x 5	9990AAMAA
1	20 x 5	9990AANAA
2	20 x 7	9990AAPAA
3	25 x 9	9990AAQAA
4	30 x 11	9990AARAA
5	38 x 10	9990AASAA
6	38 x 14	9990AATAA
7	45 x 14	9990AAUAA
8	45 x 18	9990AAVAA
9	55 x 16	9990AAWAA
10	55 x 22	9990AAXAA
11	65 x 18	9990AAYAA
12	65 x 25	9990AAZAA
13	75 x 20	9990AA0AA
14	75 x 30	9990AA1AA
15	90 x 22	9990AA2AA
16	90 x 36	9990AA3AA
17	105 x 22	9990AA4AA
18	105 x 36	9990AA5AA

UNSERE PRÄZISION IST IHR ERFOLG
OUR PRECISION IS YOUR SUCCESS

GEWINDELEHREN

Thread gauges
Calibres de contrôle
Calibri filettati



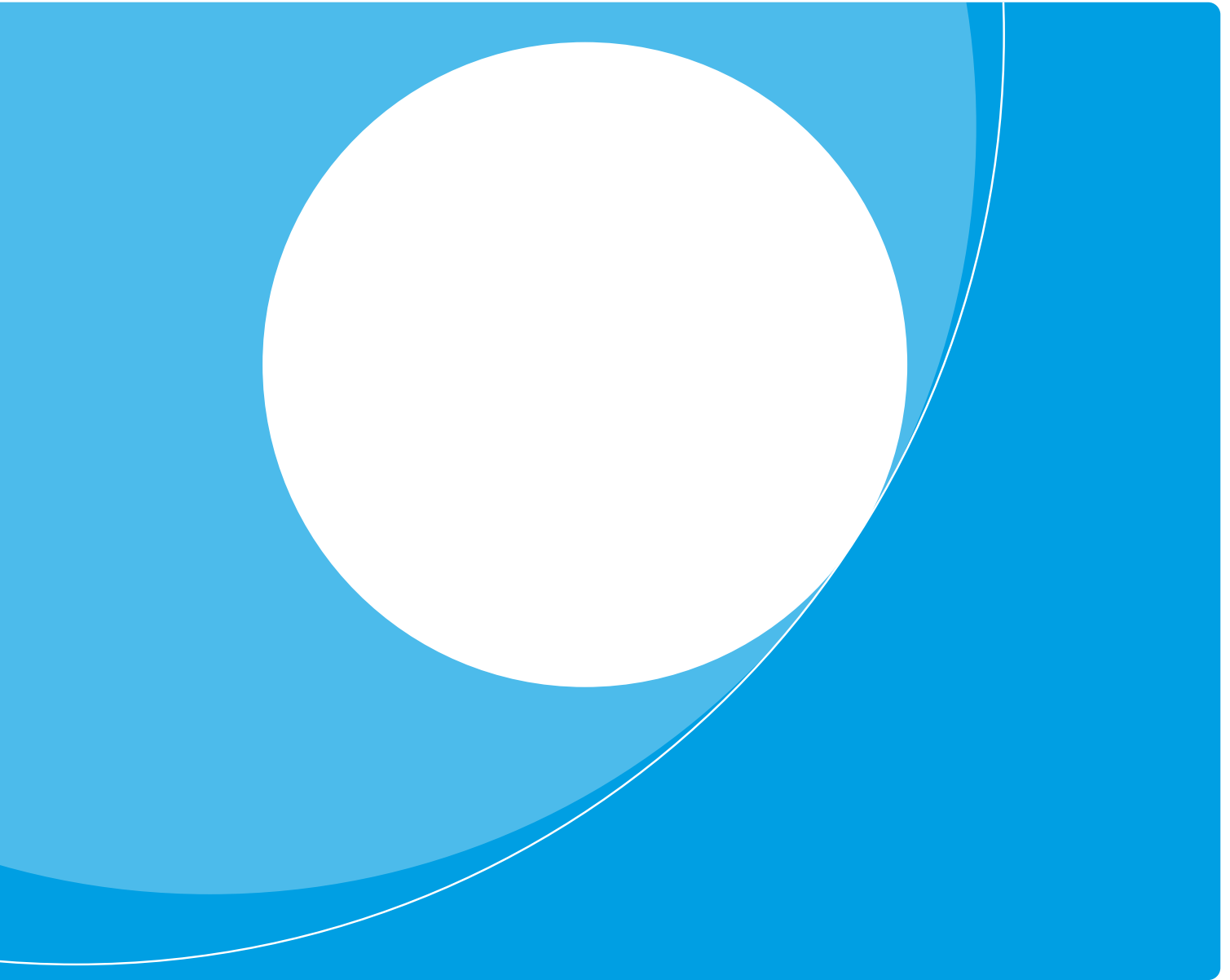

TOLERANZ / TOLERANCE TOLLERANZA / TOLLERANZA			5H	6H	6G	5H	6H	5H	6H
M	1	0,25	L100HA2103			L101HA2151		L102HA2190	
M	1,1	0,25	L100HA2104			L101HA2152		L102HA2191	
M	1,2	0,25	L100HA2105			L101HA2153		L102HA2192	
M	1,4	0,3	L100HA2106			L101HA2154		L102HA2193	
M	1,6	0,35		L100HA2107			L101HA2155		L102HA2194
M	1,8	0,35		L100HA2108			L101HA2156		L102HA2195
M	2	0,4		L100HA2109	L100GA2134		L101HA2157		L102HA2196
M	2,2	0,45		L100HA2110	L100GA2135		L101HA2158		L102HA2197
M	2,5	0,45		L100HA2111	L100GA2136		L101HA2159		L102HA2198
M	3	0,5		L100HA2112	L100GA2137		L101HA2160		L102HA2199
M	3,5	0,6		L100HA2113	L100GA2138		L101HA2161		L102HA2200
M	4	0,7		L100HA2114	L100GA2139		L101HA2162		L102HA2201
M	4,5	0,75		L100HA2115			L101HA2163		L102HA2202
M	5	0,8		L100HA2116	L100GA2140		L101HA2164		L102HA2203
M	6	1		L100HA2117	L100GA2141		L101HA2165		L102HA2204
M	7	1		L100HA2118			L101HA2166		L102HA2205
M	8	1,25		L100HA2119	L100GA2142		L101HA2167		L102HA2206
M	9	1,25		L100HA2120			L101HA2168		L102HA2207
M	10	1,5		L100HA2121	L100GA2143		L101HA2169		L102HA2208
M	12	1,75		L100HA2122	L100GA2144		L101HA2170		L102HA2209
M	14	2		L100HA2123	L100GA2145		L101HA2171		L102HA2210
M	16	2		L100HA2124	L100GA2146		L101HA2172		L102HA2211
M	18	2,5		L100HA2125	L100GA2147		L101HA2173		L102HA2212
M	20	2,5		L100HA2126	L100GA2148		L101HA2174		L102HA2213
M	22	2,5		L100HA2127	L100GA2149		L101HA2175		L102HA2214
M	24	3		L100HA2128	L100GA2150		L101HA2176		L102HA2215
M	27	3		L100HA2129			L101HA2177		L102HA2216
M	30	3,5		L100HA2130			L101HA2178		L102HA2217
M	33	3,5		L100HA2131			L101HA2179		L102HA2218
M	36	4		L100HA2132			L101HA2180		L102HA2219
M	39	4		L100HA2133			L101HA2181		L102HA2220
M	42	4,5					L101HA2182		L102HA2221
M	45	4,5					L101HA2183		L102HA2222
M	48	5					L101HA2184		L102HA2223
M	52	5					L101HA2185		L102HA2224
M	56	5,5					L101HA2186		L102HA2225
M	60	5,5					L101HA2187		L102HA2226
M	64	6					L101HA2188		L102HA2227
M	68	6					L101HA2189		L102HA2228

6h	6g	6h	6g	
L200GA2229		L201GA2268		M 1 0,25
L200GA2230		L201GA2269		M 1,1 0,25
L200GA2231		L201GA2270		M 1,2 0,25
L200GA2232		L201GA2271		M 1,4 0,3
	L200GA2233		L201GA2272	M 1,6 0,35
	L200GA2234		L201GA2273	M 1,8 0,35
	L200GA2235		L201GA2274	M 2 0,4
	L200GA2236		L201GA2275	M 2,2 0,45
	L200GA2237		L201GA2276	M 2,5 0,45
	L200GA2238		L201GA2277	M 3 0,5
	L200GA2239		L201GA2278	M 3,5 0,6
	L200GA2240		L201GA2279	M 4 0,7
	L200GA2241		L201GA2280	M 4,5 0,75
	L200GA2242		L201GA2281	M 5 0,8
	L200GA2243		L201GA2282	M 6 1
	L200GA2244		L201GA2283	M 7 1
	L200GA2245		L201GA2284	M 8 1,25
	L200GA2246		L201GA2285	M 9 1,25
	L200GA2247		L201GA2286	M 10 1,5
	L200GA2248		L201GA2287	M 12 1,75
	L200GA2249		L201GA2288	M 14 2
	L200GA2250		L201GA2289	M 16 2
	L200GA2251		L201GA2290	M 18 2,5
	L200GA2252		L201GA2291	M 20 2,5
	L200GA2253		L201GA2292	M 22 2,5
	L200GA2254		L201GA2293	M 24 3
	L200GA2255		L201GA2294	M 27 3
	L200GA2256		L201GA2295	M 30 3,5
	L200GA2257		L201GA2296	M 33 3,5
	L200GA2258		L201GA2297	M 36 4
	L200GA2259		L201GA2298	M 39 4
	L200GA2260		L201GA2299	M 42 4,5
	L200GA2261		L201GA2300	M 45 4,5
	L200GA2262		L201GA2301	M 48 5
				M 52 5
				M 56 5,5
				M 60 5,5
				M 64 6
				M 68 6

TOLERANZ / TOLERANCE TOLLERANZA / TOLLERANZA	6H	6H	6H	6g	6g
MF 2,5 x 0,35	L100HA2309	L101HA2449	L102HA2923	L200GA3397	L201GA3871
MF 3 x 0,35	L100HA2310	L101HA2450	L102HA2924	L200GA3398	L201GA3872
MF 3,5 x 0,35	L100HA2311	L101HA2451	L102HA2925	L200GA3399	L201GA3873
MF 4 x 0,35	L100HA2312	L101HA2452	L102HA2926	L200GA3400	L201GA3874
MF 4 x 0,5	L100HA2325	L101HA2465	L102HA2939	L200GA3413	L201GA3887
MF 4,5 x 0,5	L100HA2326	L101HA2466	L102HA2940	L200GA3414	L201GA3888
MF 5 x 0,5	L100HA2327	L101HA2467	L102HA2941	L200GA3415	L201GA3889
MF 6 x 0,5	L100HA2328	L101HA2468	L102HA2942	L200GA3416	L201GA3890
MF 6 x 0,75	L100HA2344	L101HA2484	L102HA2958	L200GA3432	L201GA3906
MF 7 x 0,75	L100HA2345	L101HA2485	L102HA2959	L200GA3433	L201GA3907
MF 8 x 0,5	L100HA2330	L101HA2470	L102HA2944	L200GA3418	L201GA3892
MF 8 x 0,75	L100HA2346	L101HA2486	L102HA2960	L200GA3434	L201GA3908
MF 8 x 1	L100HA2369	L101HA2509	L102HA2983	L200GA3457	L201GA3931
MF 9 x 0,75				L200GA3435	L201GA3909
MF 9 x 1	L100HA2370	L101HA2510	L102HA2984	L200GA3458	L201GA3932
MF 10 x 0,75	L100HA2348	L101HA2488	L102HA2962	L200GA3436	L201GA3910
MF 10 x 1	L100HA2371	L101HA2511	L102HA2985	L200GA3459	L201GA3933
MF 10 x 1,25	L100HA2399	L101HA2558	L102HA3032	L200GA3506	L201GA3980
MF 11 x 1	L100HA2372	L101HA2512	L102HA2986	L200GA3460	L201GA3934
MF 12 x 0,75				L200GA3438	L201GA3912
MF 12 x 1	L100HA2373	L101HA2513	L102HA2987	L200GA3461	L201GA3935
MF 12 x 1,25	L100HA2400	L101HA2559	L102HA3033	L200GA3507	L201GA3981
MF 12 x 1,5	L100HA2402	L101HA2561	L102HA3035	L200GA3509	L201GA3983
MF 13 x 1	L100HA2374	L101HA2514	L102HA2988	L200GA3462	L201GA3936
MF 13 x 1,5	L100HA2403	L101HA2562	L102HA3036	L200GA3510	L201GA3984
MF 14 x 1	L100HA2375	L101HA2515	L102HA2989	L200GA3463	L201GA3937
MF 14 x 1,25	L100HA2401	L101HA2560	L102HA3034	L200GA3508	L201GA3982
MF 14 x 1,5	L100HA2404	L101HA2563	L102HA3037	L200GA3511	L201GA3985
MF 15 x 1	L100HA2376	L101HA2516	L102HA2990	L200GA3464	L201GA3938
MF 15 x 1,5	L100HA2405	L101HA2564	L102HA3038	L200GA3512	L201GA3986
MF 16 x 1	L100HA2377	L101HA2517	L102HA2991	L200GA3465	L201GA3939
MF 16 x 1,5	L100HA2406	L101HA2565	L102HA3039	L200GA3513	L201GA3987
MF 17 x 1	L100HA2378	L101HA2518	L102HA2992	L200GA3466	L201GA3940
MF 17 x 1,5	L100HA2407	L101HA2566	L102HA3040	L200GA3514	L201GA3988
MF 18 x 1	L100HA2379	L101HA2519	L102HA2993	L200GA3467	L201GA3941
MF 18 x 1,5	L100HA2408	L101HA2567	L102HA3041	L200GA3515	L201GA3989
MF 18 x 2	L100K00430	L101K00431	L102K00432	L200K00433	L201K00434
MF 20 x 1	L100HA2381	L101HA2521	L102HA2995	L200GA3469	L201GA3943
MF 20 x 1,5	L100HA2409	L101HA2568	L102HA3042	L200GA3516	L201GA3990
MF 20 x 2	L100HA2425	L101HA2671	L102HA3145	L200GA3619	L201GA4093
MF 22 x 1	L100HA2383	L101HA2523	L102HA2997	L200GA3471	L201GA3945
MF 22 x 1,5	L100HA2410	L101HA2569	L102HA3043	L200GA3517	L201GA3991
MF 22 x 2	L100HA2426	L101HA2672	L102HA3146	L200GA3620	L201GA4094
MF 24 x 1	L100HA2385	L101HA2525	L102HA2999	L200GA3473	L201GA3947
MF 24 x 1,5	L100HA2411	L101HA2570	L102HA3044	L200GA3518	L201GA3992
MF 24 x 2	L100HA2427	L101HA2673	L102HA3147	L200GA3621	L201GA4095
MF 25 x 1	L100HA2386	L101HA2526	L102HA3000	L200GA3474	L201GA3948
MF 25 x 1,5	L100HA2412	L101HA2571	L102HA3045	L200GA3519	L201GA3993
MF 25 x 2	L100HA2428	L101HA2674	L102HA3148	L200GA3622	L201GA4096
MF 26 x 1	L100HA2387	L101HA2527	L102HA3001	L200GA3475	L201GA3949
MF 26 x 1,5	L100HA2413	L101HA2572	L102HA3046	L200GA3520	L201GA3994
MF 26 x 2	L100HA2429	L101HA2675	L102HA3149	L200GA3623	L201GA4097
MF 27 x 1	L100HA2388	L101HA2528	L102HA3002	L200GA3476	L201GA3950
MF 27 x 1,5	L100HA2414	L101HA2573	L102HA3047	L200GA3521	L201GA3995
MF 27 x 2	L100HA2430	L101HA2676	L102HA3150	L200GA3624	L201GA4098

TOLERANZ / TOLERANCE TOLERANCE / TOLLERANZA	6H	6H	6H	6g	6g
MF 28 x 1	L100HA2389	L101HA2529	L102HA3003	L200GA3477	L201GA3951
MF 28 x 1,5	L100HA2415	L101HA2574	L102HA3048	L200GA3522	L201GA3996
MF 28 x 2	L100HA2431	L101HA2677	L102HA3151	L200GA3625	L201GA4099
MF 30 x 1	L100HA2390	L101HA2530	L102HA3004	L200GA3478	L201GA3952
MF 30 x 1,5	L100HA2416	L101HA2575	L102HA3049	L200GA3523	L201GA3997
MF 30 x 2	L100HA2432	L101HA2678	L102HA3152	L200GA3626	L201GA4100
MF 30 x 3	L100HA2441	L101HA2774	L102HA3248		
MF 32 x 1	L100HA2391	L101HA2531	L102HA3005		
MF 32 x 1,5	L100HA2417	L101HA2576	L102HA3050		
MF 32 x 2	L100HA2433	L101HA2679	L102HA3153		
MF 33 x 1	L100HA2392	L101HA2532	L102HA3006		
MF 33 x 1,5	L100HA2418	L101HA2577	L102HA3051		
MF 33 x 2	L100HA2434	L101HA2680	L102HA3154		
MF 33 x 3	L100HA2442	L101HA2775	L102HA3249		
MF 34 x 1	L100HA2393	L101HA2533	L102HA3007		
MF 34 x 1,5	L100HA2419	L101HA2578	L102HA3052		
MF 34 x 2	L100HA2435	L101HA2681	L102HA3155		
MF 35 x 1	L100HA2394	L101HA2534	L102HA3008		
MF 35 x 1,5	L100HA2420	L101HA2579	L102HA3053		
MF 35 x 2	L100HA2436	L101HA2682	L102HA3156		
MF 36 x 1	L100HA2395	L101HA2535	L102HA3009		
MF 36 x 1,5	L100HA2421	L101HA2580	L102HA3054		
MF 36 x 2	L100HA2437	L101HA2683	L102HA3157		
MF 36 x 3	L100HA2443	L101HA2776	L102HA3250		
MF 38 x 1	L100HA2396	L101HA2536	L102HA3010		
MF 38 x 2	L100HA2438	L101HA2684	L102HA3158		
MF 39 x 1	L100HA2397	L101HA2537	L102HA3011		
MF 39 x 1,5	L100HA2423	L101HA2582	L102HA3056		
MF 39 x 2	L100HA2439	L101HA2685	L102HA3159		
MF 40 x 1	L100HA2398	L101HA2538	L102HA3012		
MF 40 x 1,5	L100HA2424	L101HA2583	L102HA3057		
MF 40 x 2	L100HA2440	L101HA2686	L102HA3160		
MF 40 x 3	L100HA2445	L101HA2778	L102HA3252		
MF 42 x 1		L101HA2539	L102HA3013		
MF 42 x 1,5		L101HA2584	L102HA3058		
MF 42 x 2		L101HA2687	L102HA3161		
MF 42 x 3		L101HA2779	L102HA3253		
MF 45 x 1		L101HA2540	L102HA3014		
MF 45 x 1,5		L101HA2585	L102HA3059		
MF 45 x 2		L101HA2688	L102HA3162		
MF 45 x 3		L101HA2780	L102HA3254		
MF 48 x 1		L101HA2541	L102HA3015		
MF 48 x 1,5		L101HA2586	L102HA3060		
MF 48 x 2		L101HA2689	L102HA3163		
MF 48 x 3		L101HA2781	L102HA3255		
MF 50 x 1		L101HA2542	L102HA3016		
MF 50 x 1,5		L101HA2587	L102HA3061		
MF 50 x 2		L101HA2690	L102HA3164		
MF 50 x 3		L101HA2782	L102HA3256		
MF 52 x 1		L101HA2543	L102HA3017		
MF 52 x 1,5		L101HA2588	L102HA3062		
MF 52 x 2		L101HA2691	L102HA3165		
MF 52 x 3		L101HA2783	L102HA3257		

TOLERANZ / TOLERANCE TOLLERANZA / TOLLERANZA	2B	2B	2B	2A	2A
UNC Nr. 1 - 64	L100BA4343	L101BA4366	L102BA4399	L200AA4432	L201AA4465
UNC Nr. 2 - 56	L100BA4344	L101BA4367	L102BA4400	L200AA4433	L201AA4466
UNC Nr. 3 - 48	L100BA4345	L101BA4368	L102BA4401	L200AA4434	L201AA4467
UNC Nr. 4 - 40	L100BA4346	L101BA4369	L102BA4402	L200AA4435	L201AA4468
UNC Nr. 5 - 40	L100BA4347	L101BA4370	L102BA4403	L200AA4436	L201AA4469
UNC Nr. 6 - 32	L100BA4348	L101BA4371	L102BA4404	L200AA4437	L201AA4470
UNC Nr. 8 - 32	L100BA4349	L101BA4372	L102BA4405	L200AA4438	L201AA4471
UNC Nr. 10 - 24	L100BA4350	L101BA4373	L102BA4406	L200AA4439	L201AA4472
UNC Nr. 12 - 24	L100BA4351	L101BA4374	L102BA4407	L200AA4440	L201AA4473
UNC 1/4 - 20	L100BA4352	L101BA4375	L102BA4408	L200AA4441	L201AA4474
UNC 5/16 - 18	L100BA4353	L101BA4376	L102BA4409	L200AA4442	L201AA4475
UNC 3/8 - 16	L100BA4354	L101BA4377	L102BA4410	L200AA4443	L201AA4476
UNC 7/16 - 14	L100BA4355	L101BA4378	L102BA4411	L200AA4444	L201AA4477
UNC 1/2 - 13	L100BA4356	L101BA4379	L102BA4412	L200AA4445	L201AA4478
UNC 9/16 - 12	L100BA4357	L101BA4380	L102BA4413	L200AA4446	L201AA4479
UNC 5/8 - 11	L100BA4358	L101BA4381	L102BA4414	L200AA4447	L201AA4480
UNC 3/4 - 10	L100BA4359	L101BA4382	L102BA4415	L200AA4448	L201AA4481
UNC 7/8 - 9	L100BA4360	L101BA4383	L102BA4416	L200AA4449	L201AA4482
UNC 1 - 8	L100BA4361	L101BA4384	L102BA4417	L200AA4450	L201AA4483
UNC 1 1/8 - 7	L100BA4362	L101BA4385	L102BA4418	L200AA4451	L201AA4484
UNC 1 1/4 - 7	L100BA4363	L101BA4386	L102BA4419	L200AA4452	L201AA4485
UNC 1 3/8 - 6	L100BA4364	L101BA4387	L102BA4420	L200AA4453	L201AA4486
UNC 1 1/2 - 6	L100BA4365	L101BA4388	L102BA4421	L200AA4454	L201AA4487
UNC 1 3/4 - 5		L101BA4389	L102BA4422	L200AA4455	L201AA4488
UNC 2 - 4,5		L101BA4390	L102BA4423	L200AA4456	L201AA4489

TOLERANZ / TOLERANCE TOLERANCE / TOLLERANZA	2B	2B	2B	2A	2A
UNF Nr. 0 - 80	L100BA4498	L101BA4522	L102BA4546	L200AA4570	L201AA4594
UNF Nr. 1 - 72	L100BA4499	L101BA4523	L102BA4547	L200AA4571	L201AA4595
UNF Nr. 2 - 64	L100BA4500	L101BA4524	L102BA4548	L200AA4572	L201AA4596
UNF Nr. 3 - 56	L100BA4501	L101BA4525	L102BA4549	L200AA4573	L201AA4597
UNF Nr. 4 - 48	L100BA4502	L101BA4526	L102BA4550	L200AA4574	L201AA4598
UNF Nr. 5 - 44	L100BA4503	L101BA4527	L102BA4551	L200AA4575	L201AA4599
UNF Nr. 6 - 40	L100BA4504	L101BA4528	L102BA4552	L200AA4576	L201AA4600
UNF Nr. 8 - 36	L100BA4505	L101BA4529	L102BA4553	L200AA4577	L201AA4601
UNF Nr. 10 - 32	L100BA4506	L101BA4530	L102BA4554	L200AA4578	L201AA4602
UNF Nr. 12 - 28	L100BA4507	L101BA4531	L102BA4555	L200AA4579	L201AA4603
UNF 1/4 - 28	L100BA4508	L101BA4532	L102BA4556	L200AA4580	L201AA4604
UNF 5/16 - 24	L100BA4509	L101BA4533	L102BA4557	L200AA4581	L201AA4605
UNF 3/8 - 24	L100BA4510	L101BA4534	L102BA4558	L200AA4582	L201AA4606
UNF 7/16 - 20	L100BA4511	L101BA4535	L102BA4559	L200AA4583	L201AA4607
UNF 1/2 - 20	L100BA4512	L101BA4536	L102BA4560	L200AA4584	L201AA4608
UNF 9/16 - 18	L100BA4513	L101BA4537	L102BA4561	L200AA4585	L201AA4609
UNF 5/8 - 18	L100BA4514	L101BA4538	L102BA4562	L200AA4586	L201AA4610
UNF 3/4 - 16	L100BA4515	L101BA4539	L102BA4563	L200AA4587	L201AA4611
UNF 7/8 - 14	L100BA4516	L101BA4540	L102BA4564	L200AA4588	L201AA4612
UNF 1 - 12	L100BA4517	L101BA4541	L102BA4565	L200AA4589	L201AA4613
UNF 1 1/8 - 12	L100BA4518	L101BA4542	L102BA4566	L200AA4590	L201AA4614
UNF 1 1/4 - 12	L100BA4519	L101BA4543	L102BA4567	L200AA4591	L201AA4615
UNF 1 3/8 - 12	L100BA4520	L101BA4544	L102BA4568	L200AA4592	L201AA4616
UNF 1 1/2 - 12	L100BA4521	L101BA4545	L102BA4569	L200AA4593	L201AA4617



3-Step-Design



3-Step-Design

TOLERANZ / TOLERANCE TOLLERANZA / TOLLERANZA	-	-
---	---	---

NPT 1/16 - 27	L100KA4722	L202KA4739
NPT 1/8 - 27	L100KA4723	L202KA4740
NPT 1/4 - 18	L100KA4724	L202KA4741
NPT 3/8 - 18	L100KA4725	L202KA4742
NPT 1/2 - 14	L100KA4726	L202KA4743
NPT 3/4 - 14	L100KA4727	L202KA4744
NPT 1 - 11,5	L100KA4728	L202KA4745
NPTF 1/16 - 27	L100KA4756	L202KA4768
NPTF 1/8 - 27	L100KA4757	L202KA4769
NPTF 1/4 - 18	L100KA4758	L202KA4770
NPTF 3/8 - 18	L100KA4759	L202KA4771
NPTF 1/2 - 14	L100KA4760	L202KA4772
NPTF 3/4 - 14	L100KA4761	L202KA4773
NPTF 1 - 11,5	L100KA4762	L202KA4774

TOLERANZ / TOLERANCE TOLERANCE / TOLLERANZA	-	-	-	A	A
G 1/16 - 28	L100A4618	L101A4628	L102A4652		
G 1/8 - 28	L100A4619	L101A4629	L102A4653	L200A4676	L201A4699
G 1/4 - 19	L100A4620	L101A4630	L102A4654	L200A4677	L201A4700
G 3/8 - 19	L100A4621	L101A4631	L102A4655	L200A4678	L201A4701
G 1/2 - 14	L100A4622	L101A4632	L102A4656	L200A4679	L201A4702
G 5/8 - 14	L100A4623	L101A4633	L102A4657	L200A4680	L201A4703
G 3/4 - 14	L100A4624	L101A4634	L102A4658	L200A4681	L201A4704
G 7/8 - 14	L100A4625	L101A4635	L102A4659	L200A4682	L201A4705
G 1 - 11	L100A4626	L101A4636	L102A4660	L200A4683	L201A4706
G 1 1/8 - 11	L100A4627	L101A4637	L102A4661	L200A4684	L201A4707
G 1 1/4 - 11		L101A4638	L102A4662	L200A4685	L201A4708
G 1 1/2 - 11		L101A4639	L102A4663	L200A4686	L201A4709
G 1 3/4 - 11		L101A4640	L102A4664	L200A4687	L201A4710
G 2 - 11		L101A4641	L102A4665	L200A4688	L201A4711

UNSERE PRÄZISION IST IHR ERFOLG
OUR PRECISION IS YOUR SUCCESS

ALLGEMEINE INFORMATIONEN

General Informations
Informations générales
Informazioni generali



UNSERE PRÄZISION IST IHR ERFOLG
OUR PRECISION IS YOUR SUCCESS

GEWINDEBOHRER

Machine taps

Tarauds machine



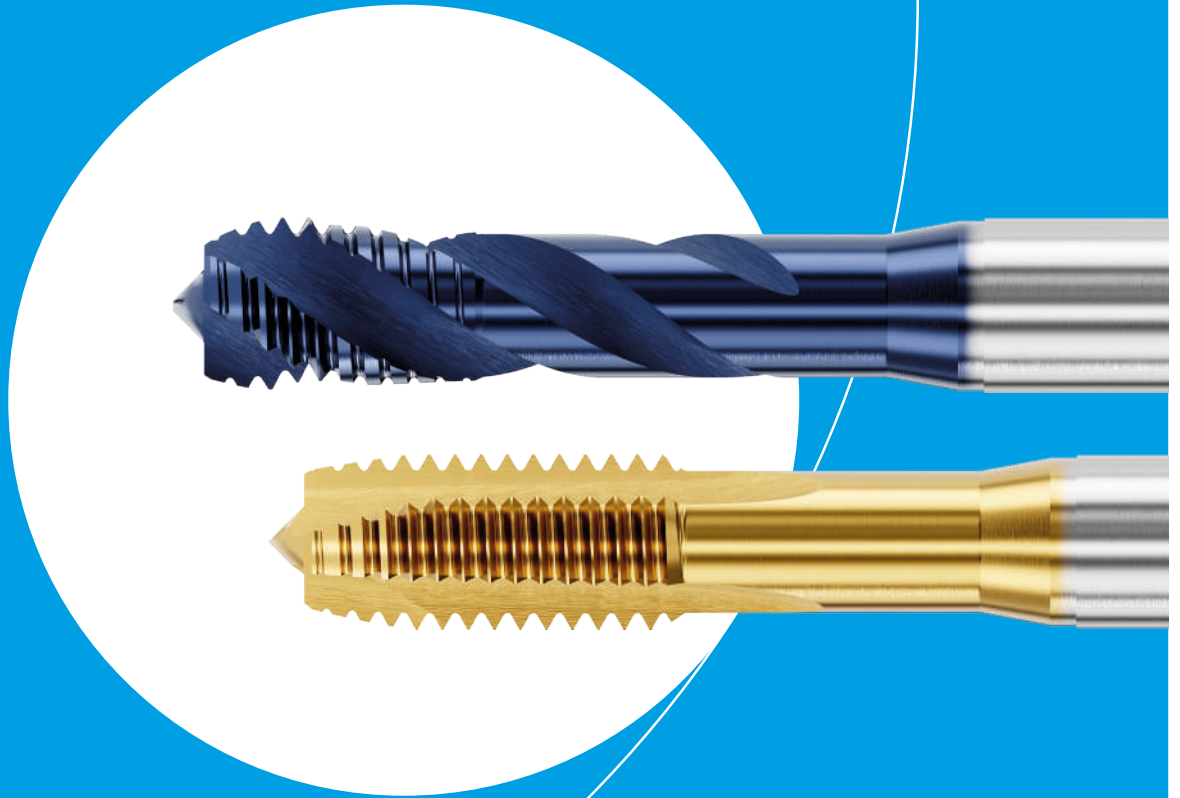

Maschi a macchina

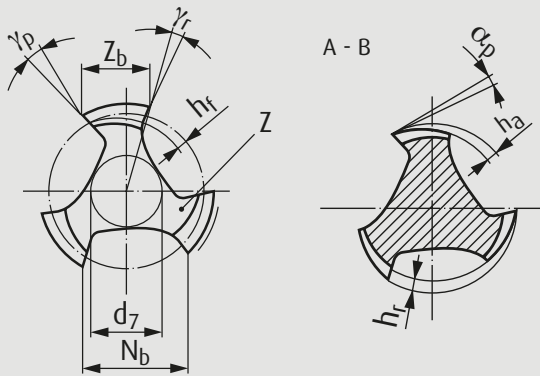
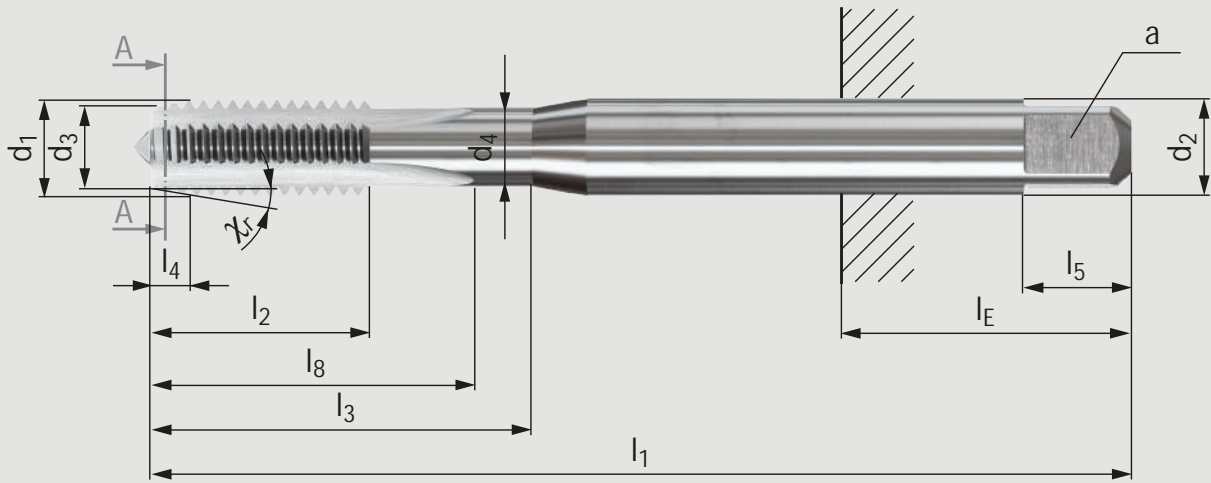

BENENNUNGEN UND DEFINITIONEN





Standard tap measurements / Dimensions et définitions du taraud / Caratteristiche e definizioni del maschio



				
d	Gewindenenddurchmesser	Thread diameter))
d	o	Shank diameter	Diamètre de queue	Gambo
d	.	Chamfer diameter))
d	=	Neck diameter	Diamètre du cou	k
d	o	Web diameter))
	8	\	o	o
	8	u	o	o
	8	y	o	o
	.	#	o	o
	†	o	o	o
	V	7	o	o
	-	#	o	o
a	Vierkantmaß	Square dimension)	U
h	.	#)	k
h	7	k)	k
h	.	#)	Rastrematura posteriore
N	Nutenbreite	†	o	o
Z	• V	V	Nombre de dents	V
Z	Zahnbreite	†	o	o



ZENTRIERUNG

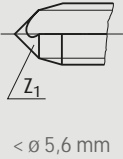
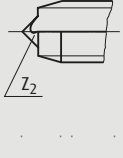
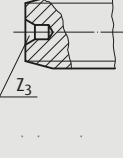
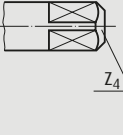

Centering / Centrage / Centratura

				
	-	Centre point	Pointe de centre	Centrino
	-	#	centre	#
	-	#	u	Foro di centratura
	Zentrierfase	#	#	Smusso per centratura

7-ku@yV8o' "' ° yU ° oo-







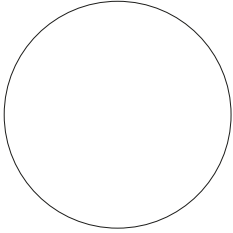

Construccion - dimensions / Encombremets / Dimensione costruttiva

" V Cat. No. No. de Cat. Cat. Nr.	u Type Type Tipo	8 Tap – Standard Tarauds – Norme Maschi – Norma				
		M	MF	G	PG	-8 U
5000 5999		DIN 352) @	DIN 5157	DIN 40432	
6000 6999		DIN 371	DIN 371			DIN 40435
7000 7999		DIN 376	DIN 374	DIN 5156	DIN 40433	DIN 40435

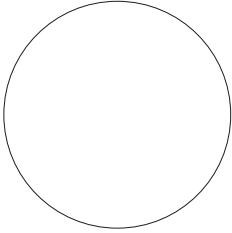
" V Cat. No. No. de Cat. Cat. Nr.	u Type Type Tipo	Gewindeformer – Norm / Cold forming taps – Standard Tarauds à refouler – Norme / Maschi a rullare – Norma				
		M	MF	G	PG	-8 U
6000 6999		DIN 2174	DIN 2174		DIN 2174	DIN 2174
7000 7999		DIN 2174	DIN 2174) @	DIN 2174	DIN 2174

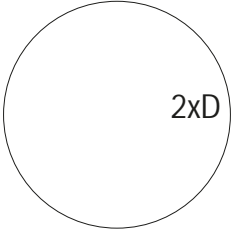







TYPENÜBERSICHT

TYPE OVERVIEW / SOMMAIRE DES TYPES / DESCRIZIONE DEL TIPO

	NORIS STABIL	NORIS DL15	NORIS TWIN
	 	  	  
	<p>V\k@u" @U 8))) 8 au" @o o o o</p>	<p>V\k@) O U 8))) 8 o o)) o o o</p>	<p>) U 8 V\k@u† @')) " o o M † †</p>
	<p>V\k@u" @)) au" @</p>	<p>V\k@) O))))</p>	<p>V\k@u† @') h u</p>
	<p>Le taraud machine NORIS STABIL pour trous) O au" @</p>	<p>O V\k@) O) O V\k@) O</p>	<p>O V\k@u† @') y #</p>
	<p>NORIS STABIL sono maschi a macchina per fori) 8 au" @</p>	<p>NORIS DL15 sono maschi a macchina per fori) 8 V\k@) O</p>	<p>NORIS TWIN sono maschi a macchina con #</p>

k - @ - \ " - k 70 # = - V " - = ° V) O y V 8 - V y V) ' " - o # = @ = u y V 8 - V

Our REIME surface treatments and coatings / Traitements de surface et revêtements REIME / Trattamenti superficiali e rivestimenti REIME

	VAP	NIT	NITVAP	TIN	TICN
					
	VAPORISIEREN	NITRIEREN	NITRIEREN + VAPORISIEREN	u@ V V@k@	u@ V # " \ V@k@
	<p>dessen wird eine fest haf</p>	<p>Beim Nitrieren wird die</p>			<p>Das Titancarbonitridbeschich</p>
	VAPORIZATION	NITRIDING	NITRIDING + VAPORIZATION	u@ V@U V@k@ -	TITANIUM CARBONITRIDE
	are heated in a steam at mosphere to 530 °C, pro	surface is enriched with ni	u nitrided and then oxidised V@ t h u combines increased surface		TICN is harder than TIN and has u
	OXYDATION	NITRURATION	TRAITEMENT VAPEUR ET OXYDATION	NITRURE DE TITANE	CARBONITRURE DE TITANE
	OSSIDAZIONE	NITRURAZIONE	NITRURAZIONE E OSSIDAZIONE	NITRURRO DI TITANIO	CARBONITRURRO DI TITANIO
	°C producendo cosi uno strato di ossido di ferro				

ALTIN



ALUMINIUMTITAN NITRID
 Durch modernste Beschichtung sehr kompakte und homogene tribochemischen und abrasiven

ALTINHD



HARTSTOFFSCHICHT + U- u' CO- M = O-Vou\ 77) - #M#=#=#=u' U- #=#

OSM



HARTSTOFFSCHICHT + U- u' CO- M = O-Vou\ 77) - #M#=#=#=u' U- #=#

DLC



AMORPHOUS CARBON COATING

TIBLU



HARD MATERIAL LAYER

ACR



ALUMINIUMCHROMNITRID

ALUMINIUM TITANIUM NITRIDE

HARD MATERIAL LAYER

HARD MATERIAL LAYER + WITH METALLIZED CARBONE COVER LAYER

AMORPHOUS CARBON COATING

HARD MATERIAL LAYER

ALUMINIUM CHROMIUM NITRIDE

LE NITRURE DE TITANE

HARD MATERIAL LAYER

COUCHE DE MATERIAU + TENEUR METALLIQUE

BONE AMORPHE

DUR

CHROME

ALLUMINIO NITRURO DI TITANIO

DURO

METALLO DURO + RIVESTIMENTO AL CARBONIO







RIVESTIMENTO IN CARBONIO AMORFO

DURO

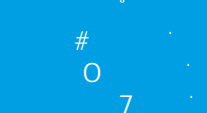
NITRURO DI ALLUMINIO E CROMO

M U " @ ° u @ VoU a 80# = M @ - V



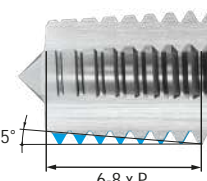
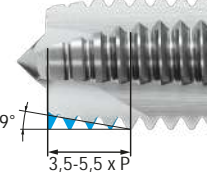
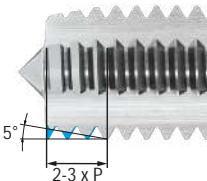
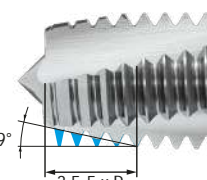
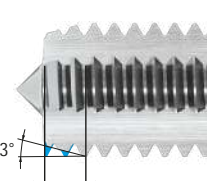
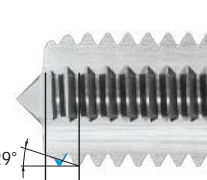
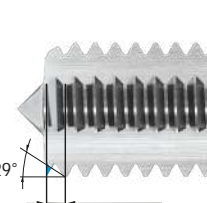

Possible combinations / Combinaisons possibles / Possibili combinazioni

Form Form Forme Forma						
A						
B						
C						
D						
E						
F						
eKA						

... M ...

8-\\ U - uk@' '-kMØ kyV8-V

Geometry Explanations / Explications Géométrie / Geometria Dichiarazioni

				
	7 " " " O	7 " " " "	h " " " "	h " " " "
	8 " " " †	u " " " "	u " " " "	U " " " "
	o " " " = " " " V ²	7 " " " V ²	h " " " V ²	Serie di maschi a mano per acciai inox, " " " V ²
	o " " " = " " " † " " " V ² oder 44 HRc	7 " " " † " " " V ² or 44 HRc	h " " " † " " " V ² ou 44 HRc	Serie di maschi a mano per acciai con re " " " V ² o 44 HRc
	7 8 " " 8KØ 8kø	7 " " " 8KØ 8kø	h " " " 8KØ 8kø	h " " " 8KØ 8kø
	7 8 " " 8KØ 8kø 8K†	7 " " " 8KØ 8kø 8K†	h " " " 8KØ 8kø 8K†	h " " " 8KØ 8kø 8K†
	7 o " " " V ²	7 " " " V ²	h " " " V ²	h " " " V ²
	7 " " " † o " " " = bis 55 HRc	7 " " " † up to 55 HRc	h " " " † =k	h " " " † =k
	7 U " " "	7 U " " "	h " " " "	h " " " "
	7 " " " U " " "	7 " " " "	h " " " "	h " " " "
	8 " " " † " " " "	# " " " "	u " " " "	U " " " "
	o " " " @ " " "	7 @ " " "	h @ " " "	h @ " " "
	7 " " " "	7 " " " "	h " " " "	h " " " "
	7 " " " † " " " "	7 " " " "	h " " " "	h " " " "
	7 " " " " o " " " "	7 " " " "	h " " " "	h " " " "
	7 u " " " u " " " "	7 u " " " u " " " "	h " " " "	h " " " "
	7 " " " " † " " " "	7 " " " "	h " " " "	h " " " "
	7 " " " V ² " " " o " " " "	7 " " " "	h " " " "	h " " " "
	7 " " " V ² " " " o " " " "	7 " " " V ² " " " "	h " " " V ² " " " "	h " " " V ² " " " "
	8 " " " " "	u " " " #V#	u " " " "	U " " " "
	" " " " † " " " k o " " " "	@ " " " † " " " ") " " " " O " " " "	h " " " U " " " "
	\ #V# o U " " " †	\ #V# " " " "	\ #V# " " " "	y macchine CNC con maschiatori per com
	† L " " " = " " " 8 " " " 8 " " " " o " " " "	u " " " " Q for the manufacture of threads at points	\ " " " " Q " " " "	y " " " " "
	8 " " " V " " " = " " " 8 " " " " "	u " " " " "	u " " " " "	U " " " " "
	† " " " o " " " " M " " " " † " " " y M " " " " M V " " " U Mk	u " " " " " U Mk U Mk	\ " " " " U Mk	y " " " " 8 " " " U Mk
	M " " " = 7 " " " " " " " " 8 " " " " " o " " " " "	# " " " " " "	7 " " " " h " " " "	U " " " " " u " " " "
	o " " " o " " " o " " " o " " " o - o " " " 8 " " " o " " " "	# " " " " u " " " "	u " " " " oh VO o	U " " " " h " " " "
	\ " " " † " " " " = o " " " " " "	\ " " " " "	\ " " " " "	y " " " " "
	7 " " " "	7 " " " "	h " " " "	h " " " "

FORMELSAMMLUNG

Formulae / Formules de calcul / Raccolta di formule

$v_c = \frac{d_1 \cdot n}{1000}$ Vitesse de coupe Nr. di giri	$n = \frac{v_c \cdot 1000}{d_1 \cdot \pi}$ [min]
--	--

$t_h = \left(\frac{L}{f} + \frac{L}{f_r} \right) \cdot 60$ [sec]

$h = \frac{L}{f}$ Feed programming	$h = \frac{L}{f}$
------------------------------------	-------------------

$U = \frac{L}{f}$ Feed path	$U = \frac{L}{f}$
Through hole Trou débouchant Foro passante	Trou borgne (taudé jusqu'au fond)

$s_s = 2 \cdot P$ Sicherheitsabstand Safety margin	$s_s = 5 \cdot P$
---	-------------------

$d = d_1 + h$ Tapping of threads: Tap drill diameter (60° thread angle)	$d = d_1 + \frac{f \cdot P}{2}$ Cold forming of threads: Tap drill diameter (60° thread angle)
---	--

FORMELSAMMLUNG

Formulae / Formules de calcul / Raccolta di formule

Maschi: Momento torcente (media durata)

$$M_D = \frac{A \cdot k_s \cdot d_1}{1000} \text{ [Nm]}$$

Maschi a rullare: Momento torcente (media durata)

$$M_D = \frac{A \cdot k_s \cdot d_1 \cdot 1,5}{1000} \text{ [Nm]}$$

$A = 0,25 \cdot P^2$ [mm²]

Indicated Power
Puissance indiquée

$$P_i = M_D \cdot \frac{1,5 \cdot n}{60} \text{ [kW]}$$

Material Selection Table

A	o	Steel materials	Aciers	Acciai	k _s
	V	V	V	V	V
	V	V	V	V	V
	V	V	V	V	V
	V	V	V	V	V
	V	V	V	V	V
R	V	Corrosion and acid proof steels	Aciers inox / résist. acides		
	V	V	V	V	V
	V	V	V	V	V
	V	V	V	V	V
F	8	Cast materials	Fontes	Ghise	
	Gusseisen	Cast iron	Fontes grises	Ghise	V
	8 M	Cast iron with nodular graphite	Fontes graphite sphéroidal	8	V
	=	=	=	8	V
H	V, U	Non ferrous materials	Matériaux non ferreux	Materiali non ferrosi	
	O	Aluminium alloys	Alliages d'aluminium	Leghe di alluminio	V
	M O	Copper alloys		Leghe rame	V
	- O	Zinc alloys		O	V
S	o †		U	U	
	V M O	V #		O	V
	k u	h u	u	u O	V
H	8 o =k	Hardened steels	Aciers traités		V
	8 o =k	= =k	=k	=k	V
	8 o =k	= =k	=k	=k	V
	k † 8			†	V

Legend

A	o	#	o
d ₁	o	V)
d	o	u)
f	o	Feed	
f _r	o	Feed on return	7
f	7	7	7
k _s	o	7	7
L	†	U	u
s	8	h	h
s	o	O	O
M _D	o	h	h
n)	#	h
P	o	V k	†
P _i	@	Pitch	Pas
t	o	Indicated Power	h
t _h	=	Layer thickness	Epaisseur
c	o	Spessore	Spessore
	†))
	o	#	#
	†	Vitesse de coupe	†
	†	k	8

UNSERE PRÄZISION IST IHR ERFOLG
OUR PRECISION IS YOUR SUCCESS

GEWINDEFRÄSER



Thread mills
Fraises à fileter
Fresa a filettare

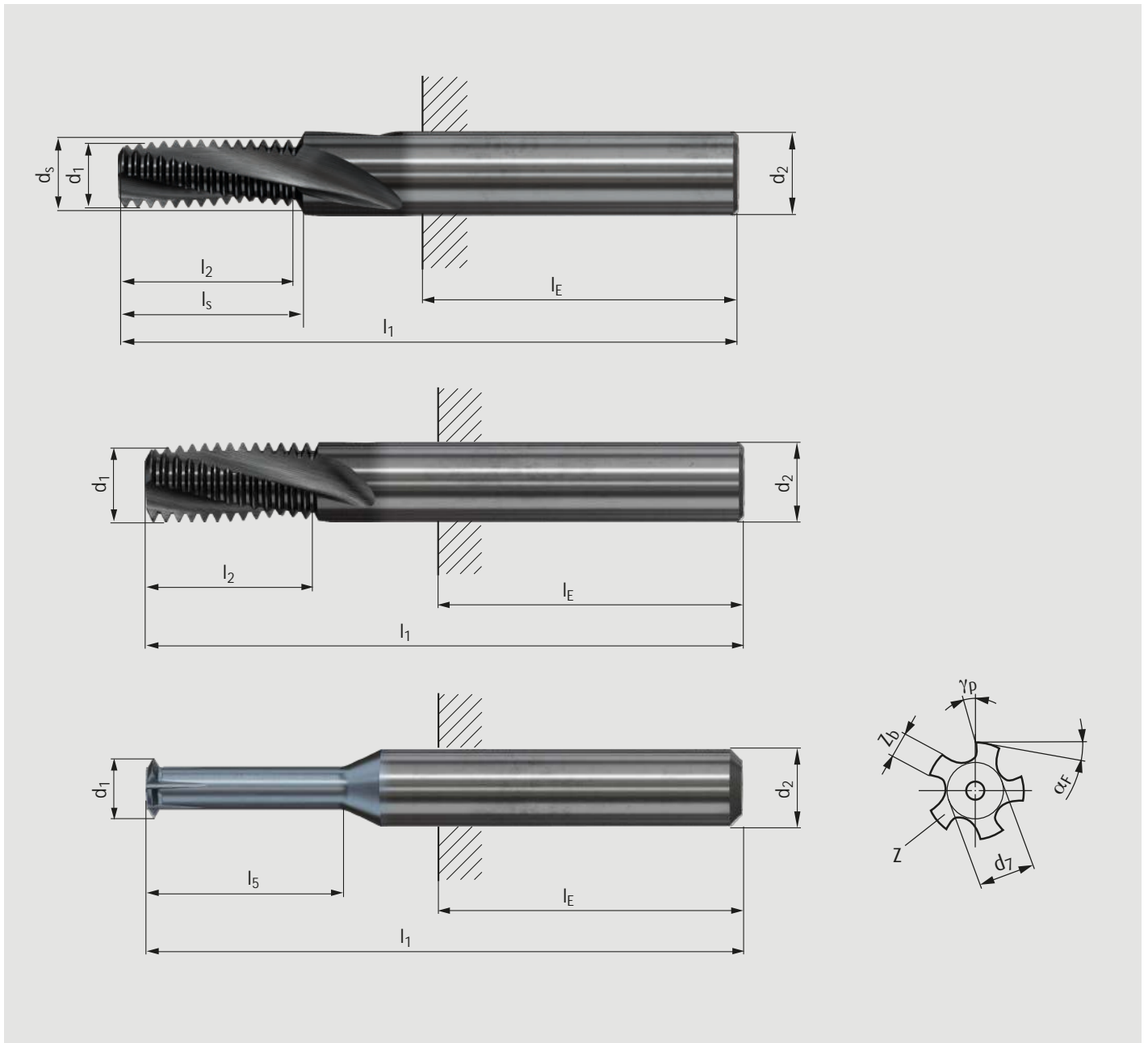

BENENNUNGEN UND DEFINITIONEN AM GEWINDEFÄRER

Thread milling cutter measurements / Caractéristiques et définitions des fraises à fileter / Caratteristiche e definizioni del frese a filettare



				
d	7)))
d	o	Shank diameter	Diamètre de queue	Gambo
d	=)))
d	o	Neck diameter)	k
d	o	Web diameter))
d)	o	7)
ds	Senkdurchmesser)	Diamètre de chanfein)
D	messer	8))
	8	\	o	o
	7	o	o	o
	-	#	o	o
	=	v	o	o
	V	y	o	o
E	-)	h	h
	u	#	Profondeur de chanfrein	h
s	o	h	.	.
	o	k	.	.
a _F	7	#	.	.
a _S	.	#	.	.
Z _b	Zahnbreite	‡	o	o
Z	-	Number of teeth	Nombre de dents	v

SYMBOLBESCHREIBUNG

Description of the symbols / Description des symboles / Descrizione dei simboli

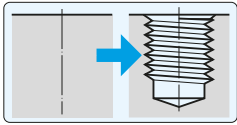

V \pm M o 8
 K \pm o 8
 o \pm o 8
 y \pm o 8

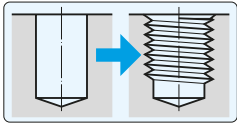

V \pm o 8
 K \pm o 8
 o \pm o 8
 y \pm o 8

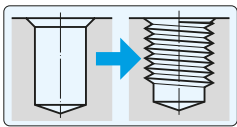

\pm o 8
 u o 8
 O o 8
 O o 8

c

o = Vorschub pro Zahn [mm]
 # = Feed per tooth
 † = Feed per tooth
 † = Feed per tooth



M
 @
 O
 h

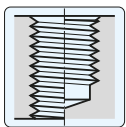

@
 o
 o
 o

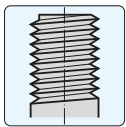

o
 o
 o

NORIS GEWINDEFÄRÄSER

THREAD MILLS / FRAISES À FILETER / FRESA A FILETTARE

GEWINDEFÄRÄSER

THREAD MILL



NORIS ZTF HT

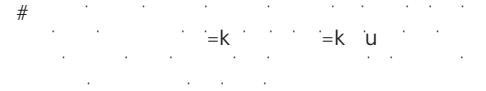
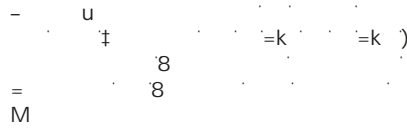

NORIS SF

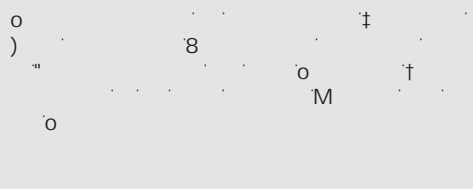

NORIS SFSE

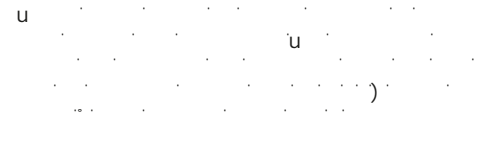
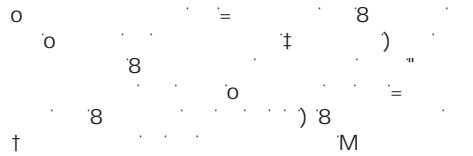

NORIS EIR HR

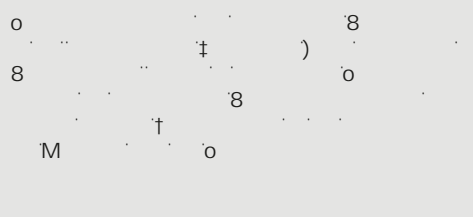

NORIS EIR HR

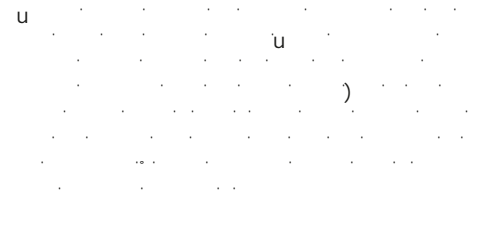
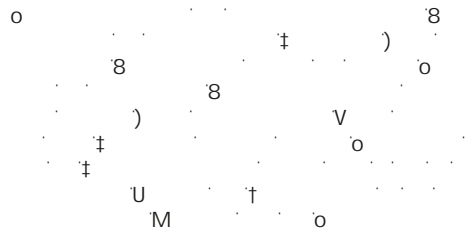

NORIS NES

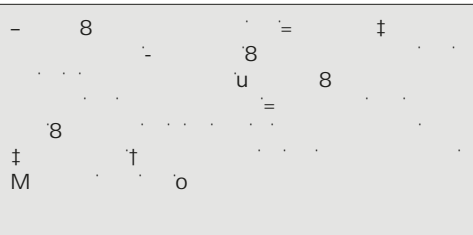

V\ k@V-o uo

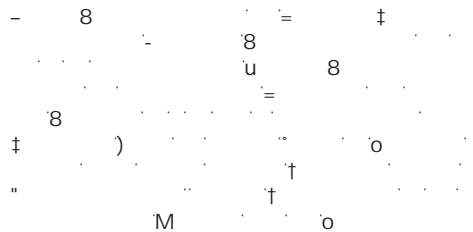

FILETAGE



7 =k =k #

7 #
o

7 #
o

7 #
o

7 #
8
o

o 7
o

o 7
o o

FRESA A FILETTARE



7 =k j

7 o k

7 o k

7 U
k

7 o k

7 h
8 o

7 h
8 o



7

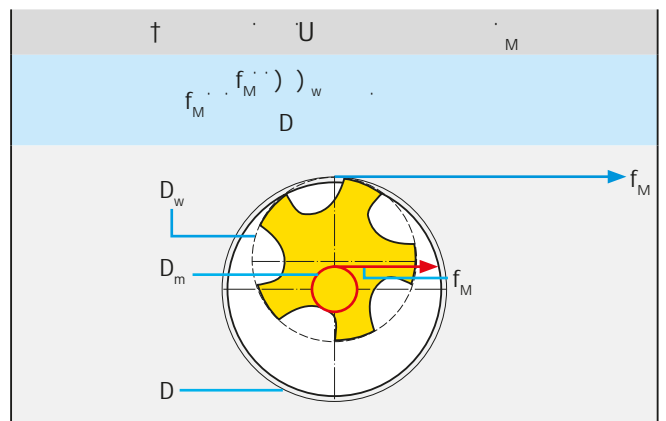
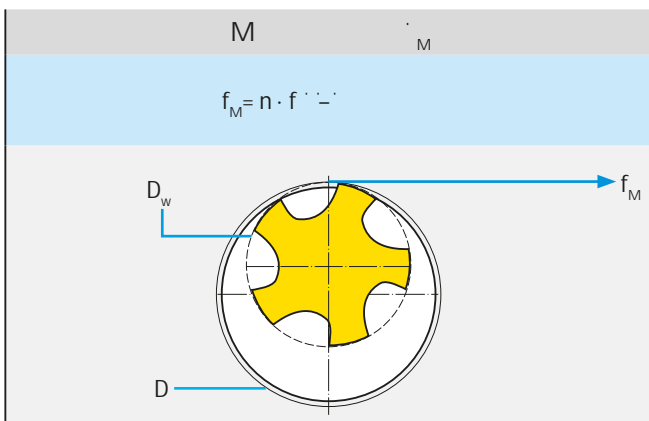
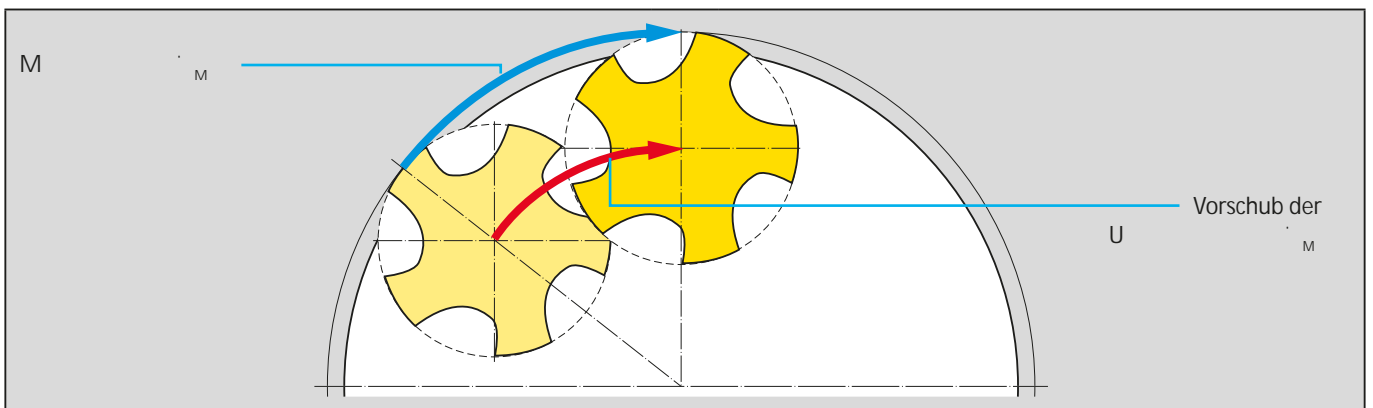
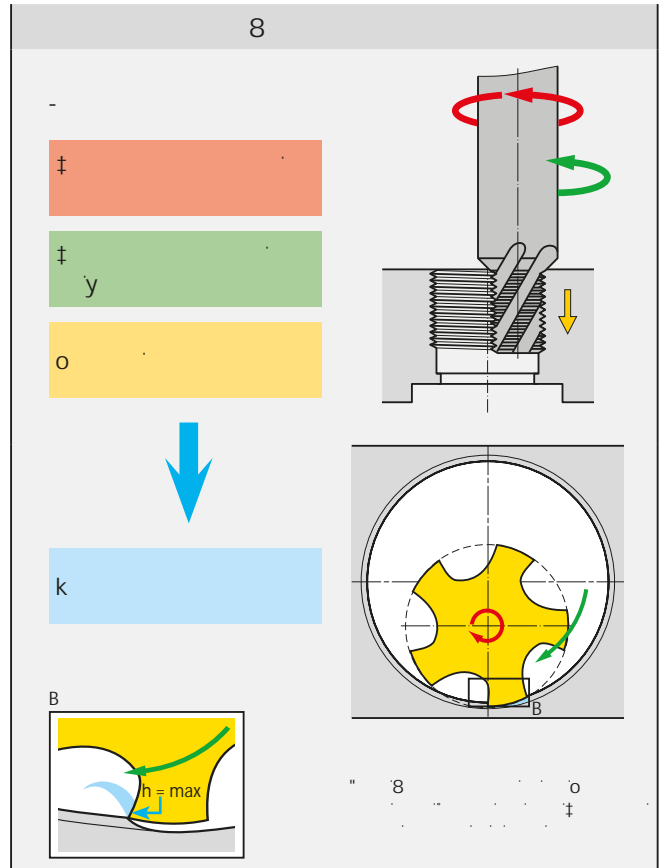
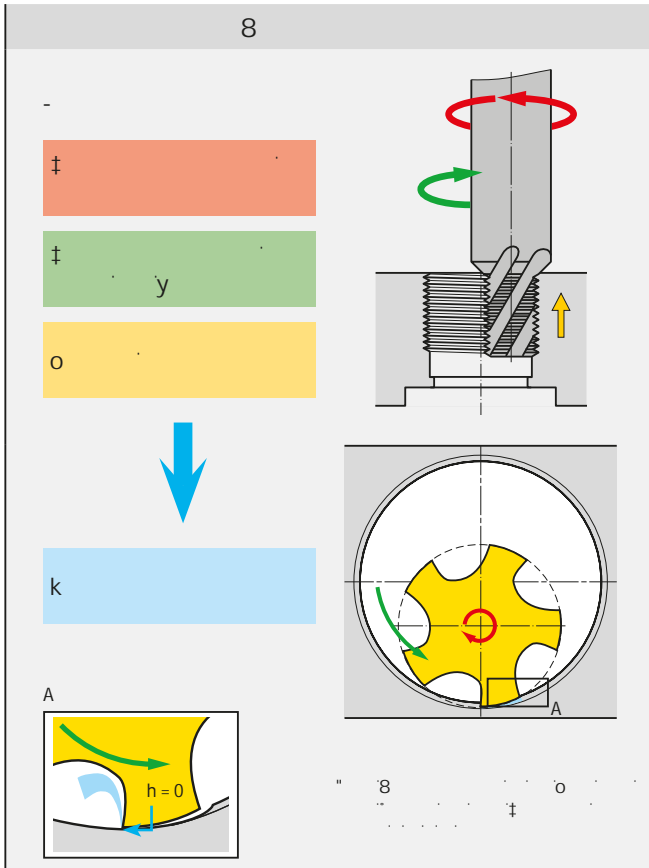

- D_w = Wirkdurchmesser [mm]
- f = Vorschub pro Zahn [mm]
- D = Nenndurchmesser Gewinde = Durchmesser Außenkontur [mm]



U

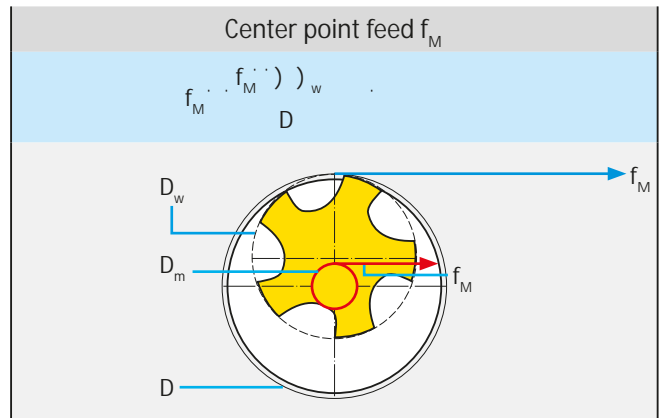
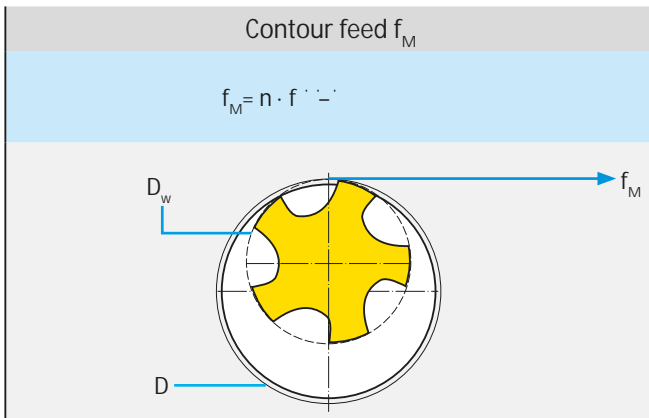
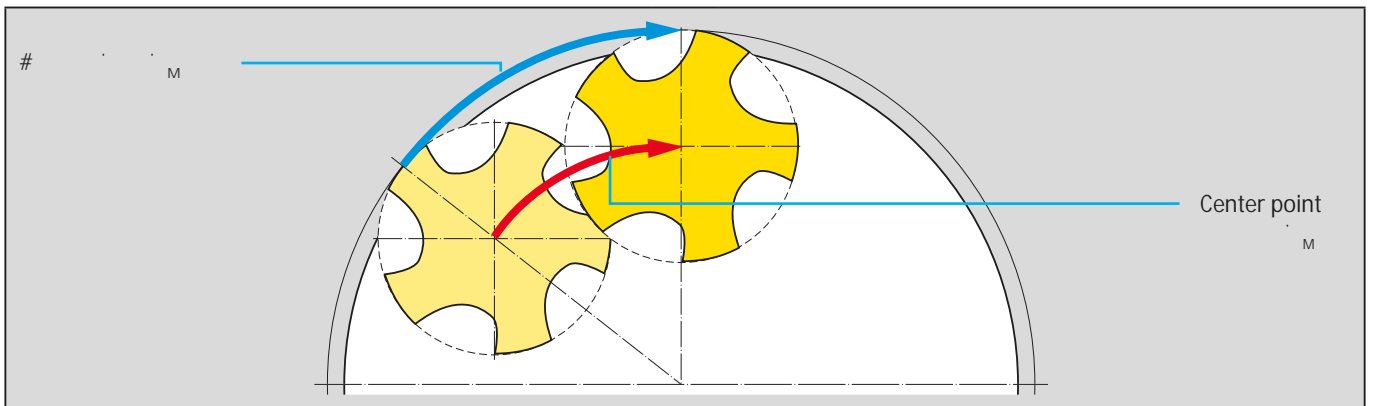
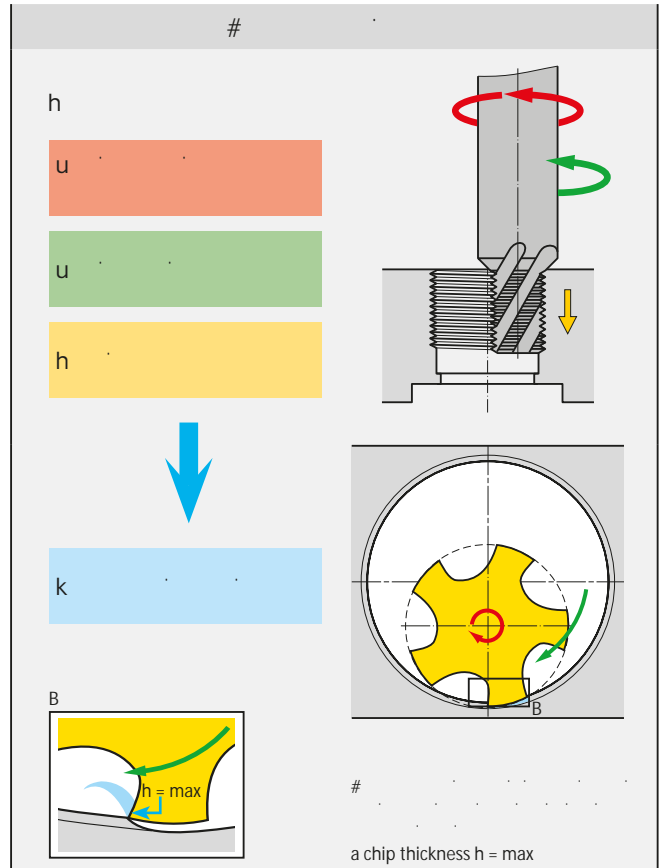
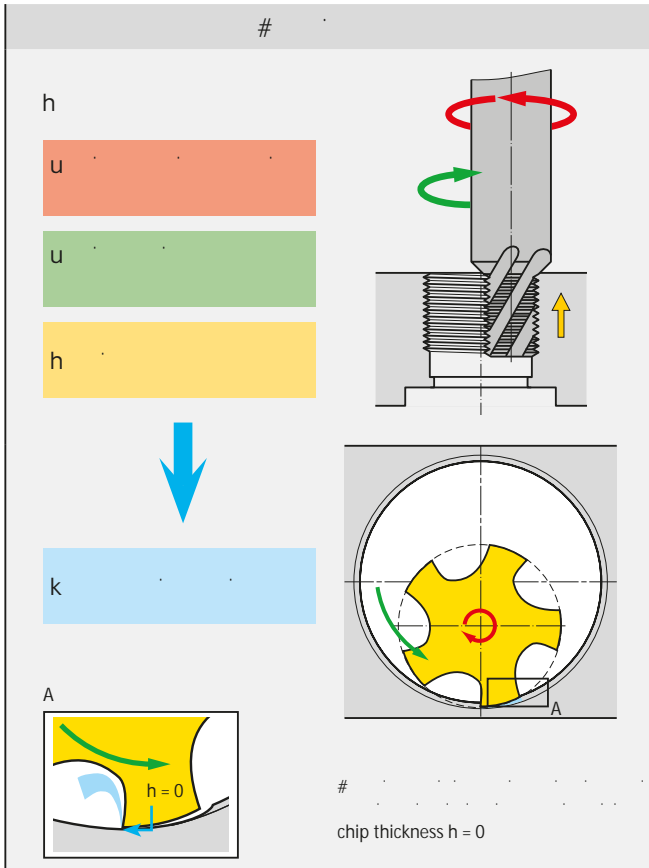

- D_w = work diameter [mm]
- n = RPM [min⁻¹]
- f = Feed per tooth [mm]
- D = diameter [mm]
- D_m = diameter of the center point [mm]



h

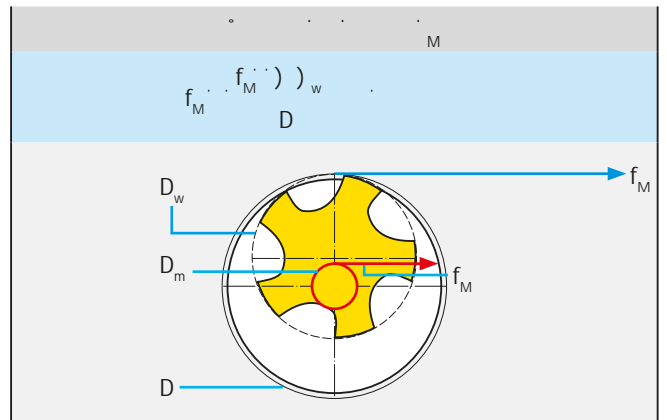
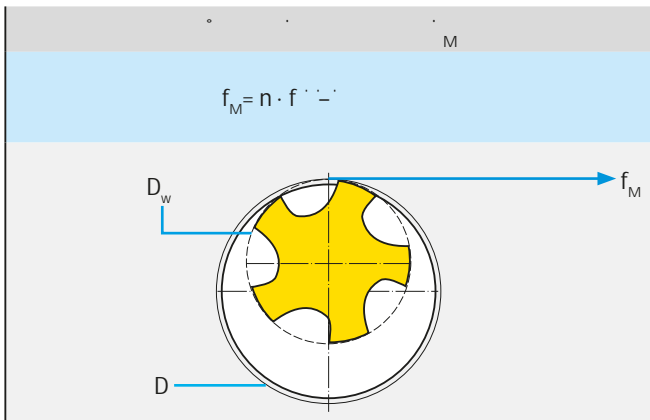
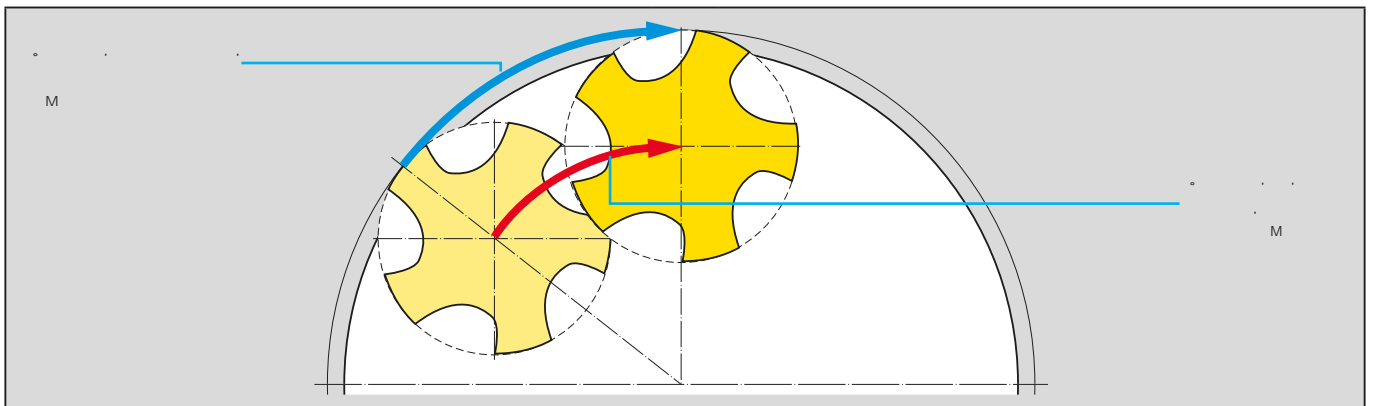
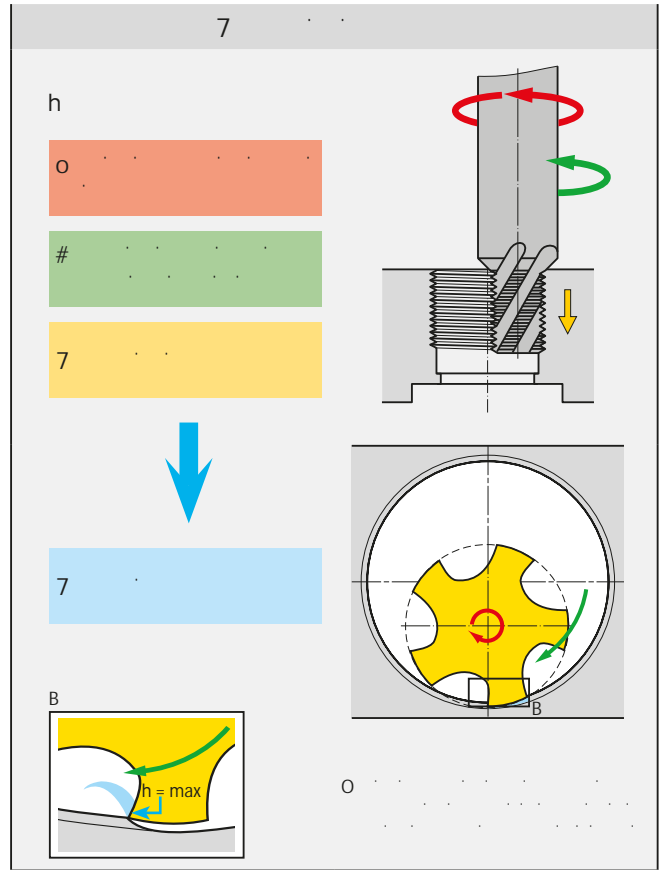
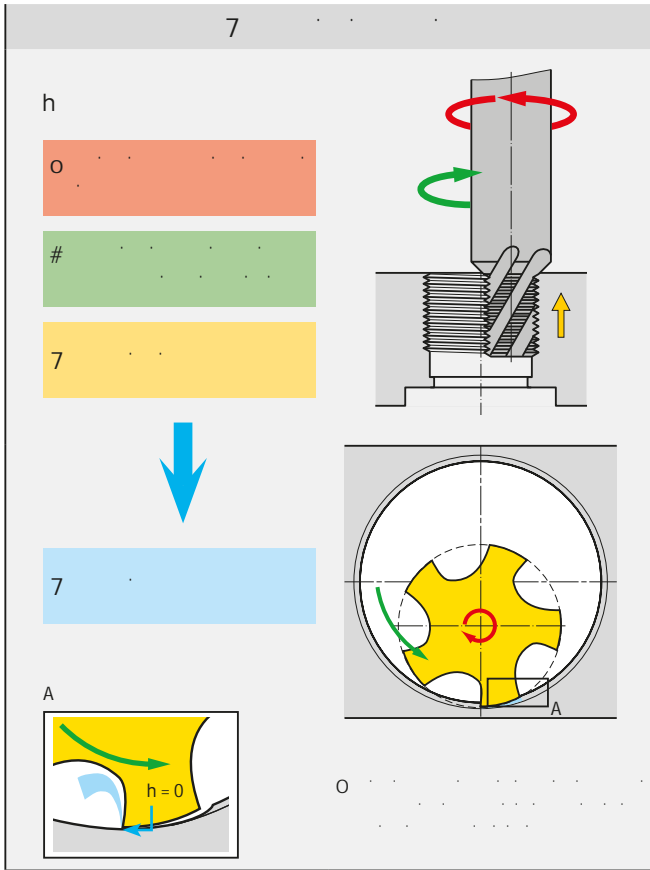

$$D_w = \left[\frac{f_M}{f' \cdot D} \right]$$

$$f' = \left[\frac{f_M \cdot D}{D_w} \right]$$

$$D_m = \left[\frac{f_M \cdot D}{D_w} \right] \cdot D$$



h

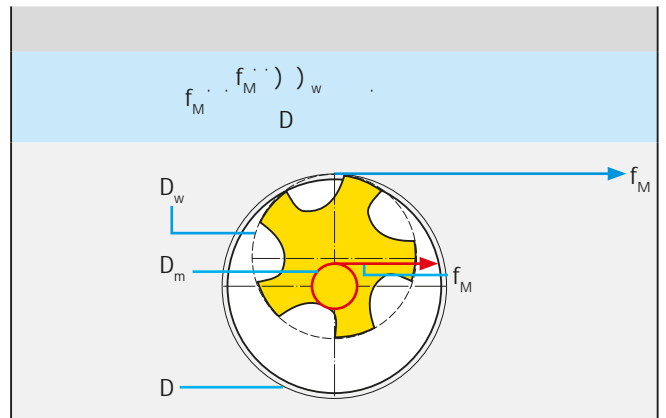
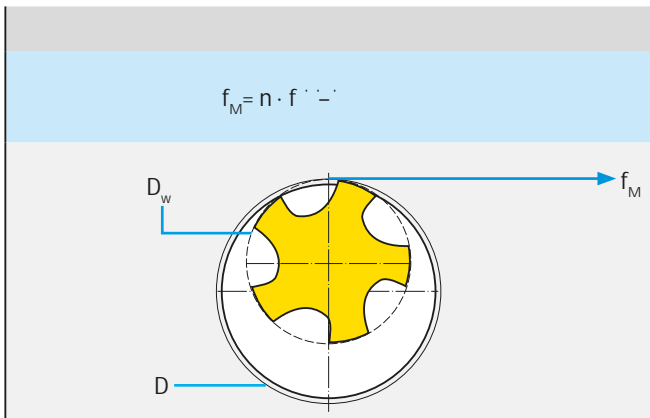
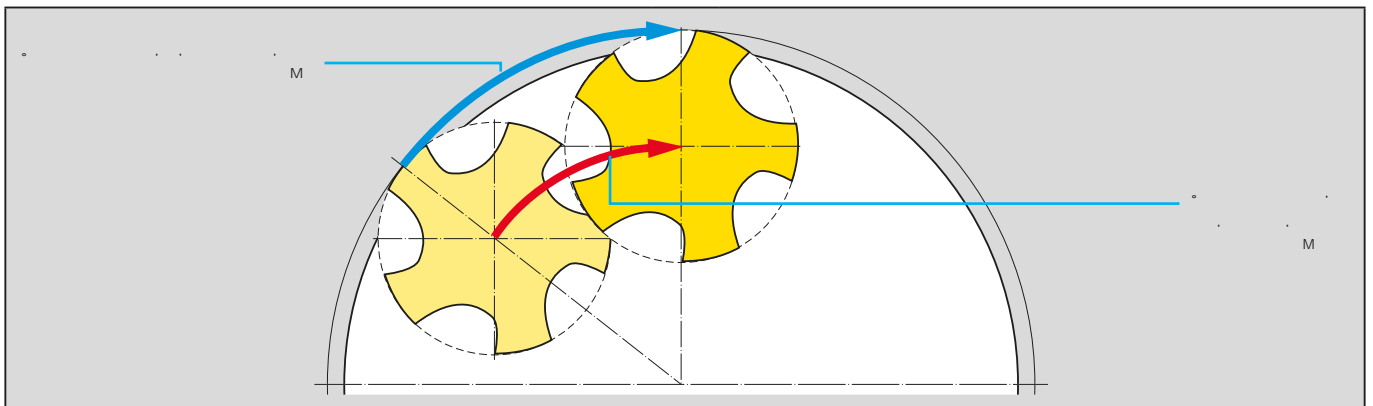
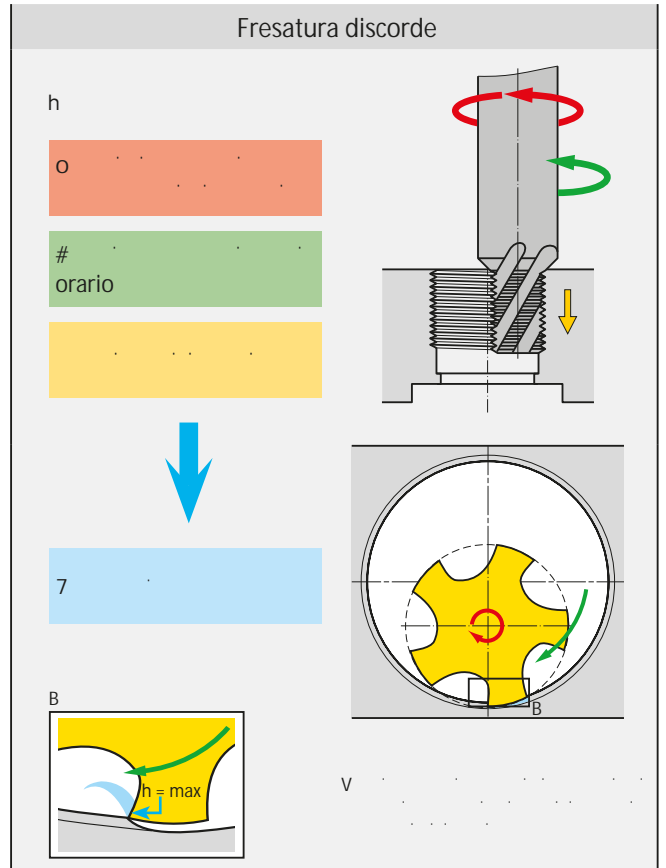
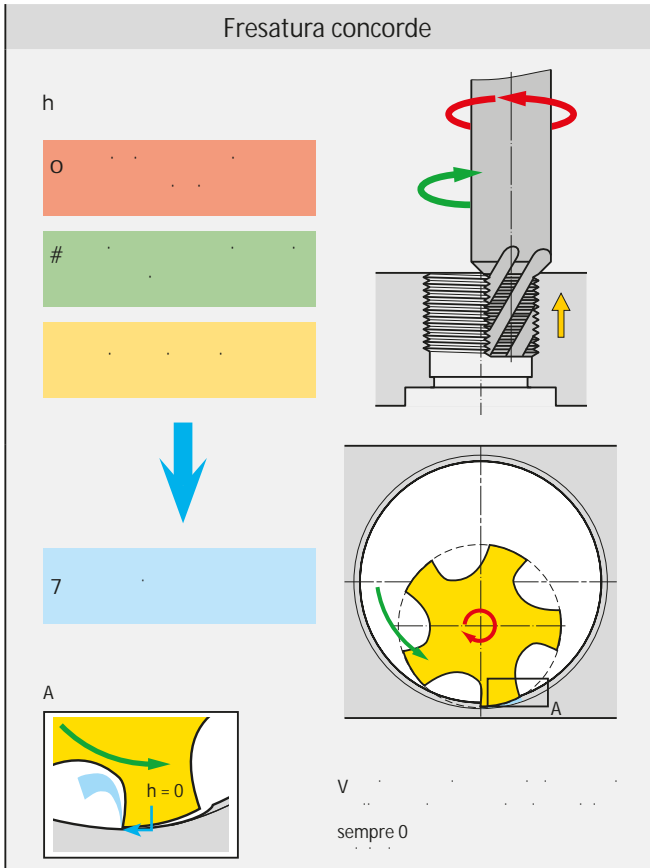

D_w [mm]

f_{rot} [mm/min]

D_m [mm]

UNSERE PRÄZISION IST IHR ERFOLG
OUR PRECISION IS YOUR SUCCESS

SCHNEIDEISEN

Dies
Filières
Filiere





SCHNEIDEISEN

Dies / Filières / Filiera

k-⊕-o# = V-⊕-⊕-V " ° y 7 kU - V
 ") ⊕ "

Formes des filières REIME / Constructional designs of our REIME dies / Forme costruttive delle filiere REIME
 Formes selon DIN (exemples) / Constructional designs acc. DIN (examples) / Forme costruttive secondo DIN (esempi)

	#	Bauform Forme	Baumaße	k-⊕-o# k-⊕- k-⊕- k-⊕-
	7	Runde Schneideisen Round dies Filiere tonde) ⊕ - V	standard normale normali lapped rodées lappate standard normale normali lapped rodées lappate lapped rodées lappate
	8 7	Acorn dies Filiere a campana		lapped rodées lappate lapped rodées lappate

OBERFLÄCHENBEHANDLUNGEN

Surface treatment / Traitement de surface / U

2020 2720 2045			
NORMAL \	STANDARD No special surface treatment.	NORMALE Sans traitement de surface	NORMALI o
GELÄPPT) 8 o	LAPPED The lapped thread surface formance.	RODÉE O meilleur résultat de coupe.	LAPPATE O di taglio.

SCHNEIDEISEN

Dies / Filières / Filiere

8- \ U - uk@ ' - kM kyV8- V

8 / - / - 8 / 8)

2020 | 2030 | 2230

<p>FÜR GUT SPANBARE ou° =Ç - kM u\ 77- Diese Schneideisen sind mit</p> 	<p>FOR STEELS WITH GOOD MACHINING CAPACITY <i>These dies are made with a spiral</i></p> 	<p>POUR LES ACIERS FACILES À USINER # <i>entrée GUN pour donner au cope</i></p> 	<p>PER ACCIAI DI BUONA LAVORABILITÀ j</p> 
--	--	---	--

2045 | 2055

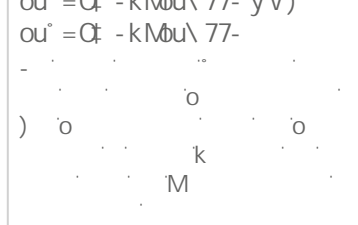
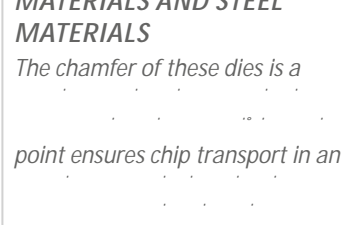
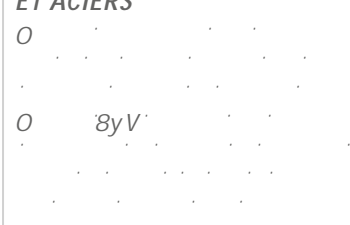
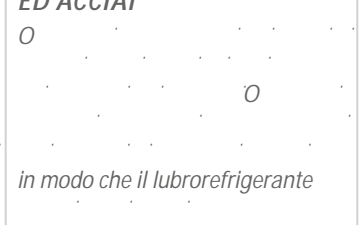
<p>FÜR NICHTROSTENDE ou° =Ç - kM u\ 77- yV) ou° =Ç - kM u\ 77- - o o o k M</p> 	<p>FOR STAINLESS STEEL MATERIALS AND STEEL MATERIALS <i>The chamfer of these dies is a</i> <i>point ensures chip transport in an</i></p> 	<p>POUR ACIERS INOXYDABLES ET ACIERS O O 8yV</p> 	<p>PER ACCIAI INOSSIDABILI ED ACCIAI O O <i>in modo che il lubrorefrigerante</i></p> 
---	---	--	--

...

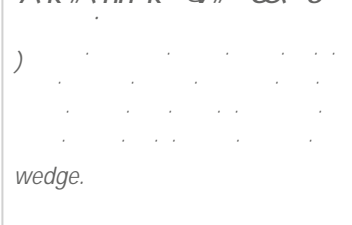
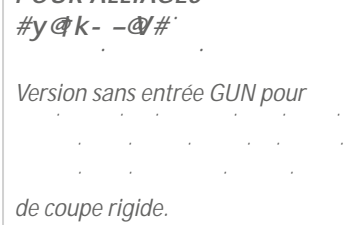
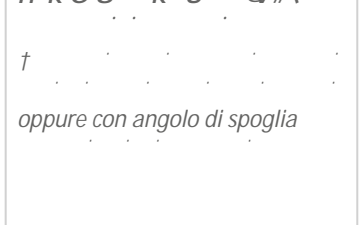
<p>7-k M y h7-k -@M LEGIERUNGEN U \ o o o</p> 	<p>7 k #\ hh-k -@#° O\ ' o) o o o o wedge.</p> 	<p>POUR ALLIAGES #y@k- -@# <i>Version sans entrée GUN pour</i> <i>de coupe rigide.</i></p> 	<p>h-k O8=- k° U - -@#\ t o o o <i>oppure con angolo di spoglia</i></p> 
--	---	--	--

UNSERE PRÄZISION IST IHR ERFOLG
OUR PRECISION IS YOUR SUCCESS

GEWINDELEHREN

Thread gauges
Calibres de contrôle
Calibri filettati

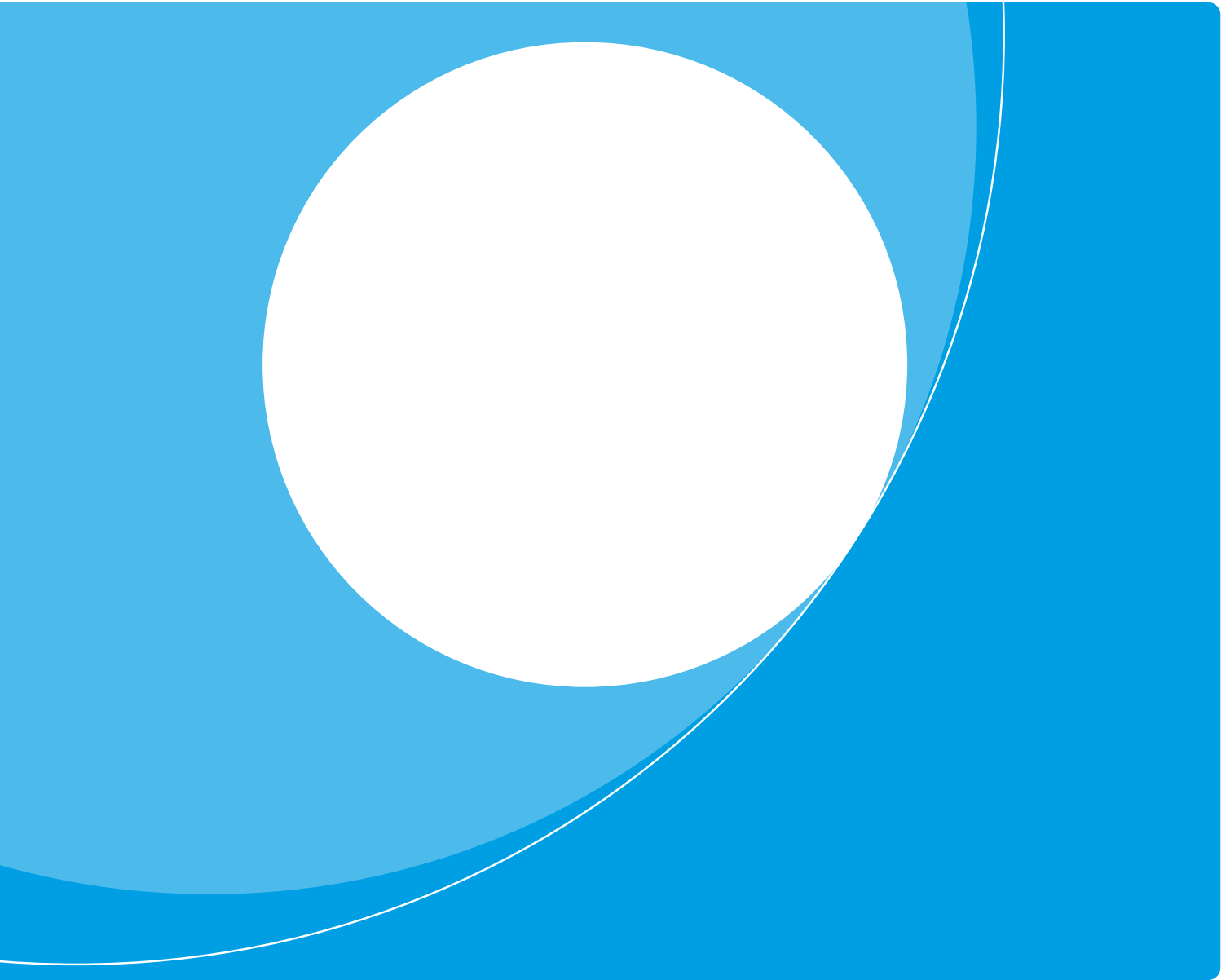

GEWINDELEHREN

Thread gauges / Calibres filetés / Calibri filettati

ALLGEMEINES
 7 U 8
 in DIN ISO 1502 ein Lehrsensystem

†

8

8 @ 8

" 7

h

) " †

8 @ 8

" 7

h

V 8

" h

" U " U

U

@ - U

) @ 8 V

h O

7 8 "

O 8

† 7

U

h

) " O U

† u

GENERAL INFORMATION
 7 U 8

) @
 ring the unlimited exchangeability of

The following basic principles apply:
 1. The manufacturer must not supply

diameter).

ü

limits

diameter).

@

†

@
 recommended in the standard
 DIN ISO 1502 will decide the

U -

tric ISO thread.

7

apply.

@

absolutely necessary to perform ran

dardised gauges. The reference tem

@

INFORMATIONS GÉNÉRALES
 h U 8

) @

O

appliqués:
 1. Le fabricant ne peut pas fournir

O

)

O

En cas de doute, les calibres préconi-

sés dans la norme DIN ISO 1502 sont

Métrique ISO.

h

o

il est absolument nécessaire réaliser

les calibres normalisés. La tempéra

ture de référence pour les calibres

o

@ 7 k U ° - @ V @ 8 - V - k ° @

h @ U

) @

@

1. Il fabbricante non può fornire un

(p. es. il diametro medio o il diame

@

metro medio o il diametro medio

V

V

V

) @

ISO Metrica.

h

applicata, per i calibri, altre norme.

o

O

temperatura di riferimento per i ca

o

GEWINDELEHREN FÜR INNENGEWINDE
 7 O 8 @ 8

8 8

" 8

8 "

8 8

8 8

7 8

8 8

Gewindedurchmesser 62 mm nach

) @ - O

@ M

8 "

THREAD GAUGES FOR INTERNAL THREADS
 The go thread plug gauge and the

the gauging of internal threads. Go

on a common handle for thread dia

meters up to

7

thread plug gauges up to a thread

) @

is recommended for gauging the

internal thread minor diameter.

CALIBRES FILETÉS POUR FILETS INTÉRIEURS
 O

K

poignée et sont désignés comme tam

h

) @ h

pas lisse.

CALIBRI FILETTATI PER FILETTATURE INTERNE
 @

7

a tampone passa/non passa. Per

calibri a tampone passa/non passa

) @ h

controllo del diametro di nocciolo del

(liscio) passa/non passa.

GEWINDELEHREN

Thread gauges / Calibres filetés / Calibri filettati

8-† 8 0



8-† 8 0) - GUTLEHRDORN

• Nach DIN ISO 1502 sind keine
Lehrdorne immer in der

GO THREAD PLUG GAUGE

• The go thread plug gauge must be able to be screwed by hand into the full length of the thread plug gauge is subject to REIME therefore recommends using go thread plug gauges. The go thread plug gauge has thread length. It should be noted that the thread length piece thread. Go thread plug diameter of

CALIBRES FILETÉS POUR FILETS INTÉRIEURS

entre est déterminé par la méthode de mesure sur trois pi exposé à une usure plus forte. Les ne sont pas normalisés.

CALIBRO A TAMPONE FILETTATO PASSA

tamento. Controlla la misura misura minima del diametro esterno. Il diametro di preforo larmente controllato. REIME ricopertura in cromo duro o con

GEWINDELEHREN

Thread gauges / Calibres filetés / Calibri filettati

8-† ° 0



8-† (A) - AUSSCHUSSLEHRDORN

) 8
@
† @ 8
@ M
) 8
= M
† o
y
)
y
Ausschrauben des Lehndorns
) 8
8
) 8
7
• Die Lehren sind mit einem
7
") (A)
) (A)

V\ 8\ u=k- °) h0y8 GAUGE

ü

internal thread exceeds the
ü
internal thread major diameter
and internal thread minor dia

• It must not be possible to screw

by hand for more than two

without the use of particular
ü
determined on screwing out
the plug gauge.
ü
has a thread length of at least
three threads. The thread profi
le has a truncated crest.
ü
red coloured ring.
) (A)
) (A)
) (A)

TAMPON FILETÉ V - Vuk- h° o

O
effectif du taraudage de la
O
taraudage
O
plus de deux tours (des deux
O
tampon.
O
une longueur filetée de trois
filets au moins. Le profil de filet
est tronqué au sommet.
O
une bague rouge.
) (A)
) (A)

CALIBRO A TAMPONE FILETTATO NON PASSA

• Il calibro a tampone filettato
non passa controlla se il dia

supera la misura massima
prescritta. Il diametro esterno
ed il diametro
di preforo della filettatura in

• Il calibro a tampone filettato

di due giri (dai due lati della
filettatura).
@

• Il calibro a tampone filettato
filettato di almeno tre filetti. Il
profilo del filetto ha la cresta
ridotta.
• I calibri sono marcati con un
anello rosso.
) (A)
) (A)

8-† 8k 0



8-† (A) - GRENZLEHRDORN

) 8 8
M 8
8 8

8
• Die Baumaße der Gewin
8
Nennmaßdurchmesser 40 mm
) (A)
Funktionsweise entspricht
8 8

8\ V\ 8\ u=k- °) PLUG GAUGE

ü
gauge is the combination of
a go thread plug gauge and a

one handle.
• The dimensions of the go/

specified up to a nominal di
) (A) ü
corresponds to the go and

TAMPON FILETÉ - Vuk- V - Vuk- h° o

O
une poignée.
• Les dimensions du tampon

) (A) O
fonction correspond à celle des

CALIBRO A TAMPONE FILETTATO PASSA/NON PASSA

• Il calibro a tampone filettato

filettato passa e di un calibro a
tampone filettato non passa su

• Le dimensioni del calibro a
tampone filettato passa/non
passa sono definite fino al dia

) (A) O
corrisponde a quella dei calibri
a tampone filettati passa e non
passa descritti sopra.

GEWINDELEHREN

Thread gauges / Calibres filetés / Calibri filettati

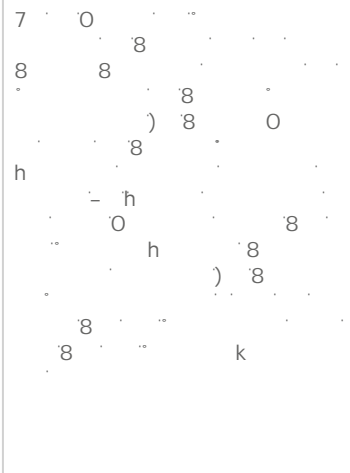
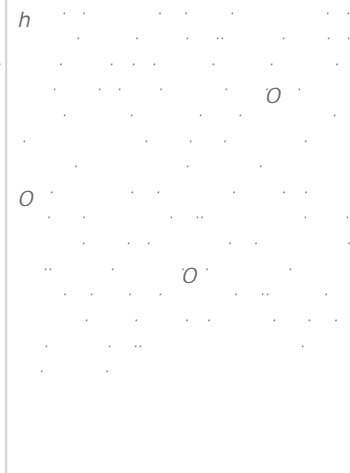
<p>GEWINDELEHREN FÜR AUSSENGEWINDE</p> 	<p>THREAD GAUGES FOR EXTERNAL THREADS</p> <p>A go thread ring gauge is used for gauging the external thread for the</p> <p>The thread ring gauges should be monitored regularly with thread wear #</p> <p>new ring gauges. The major diameter of thread d is tested with smooth go snap gauges</p>	<p>CALIBRES FILETÉS POUR FILETS EXTÉRIEURS</p> 	<p>CALIBRI FILETTATI PER FILETTATURE ESTERNE</p> <p>@</p> <p>a tampone passa/non passa. Per calibri a tampone passa/non passa controllo del diametro di nocciolo del (liscio) passa/non passa.</p>
---	---	--	---

8-† 8 Ck

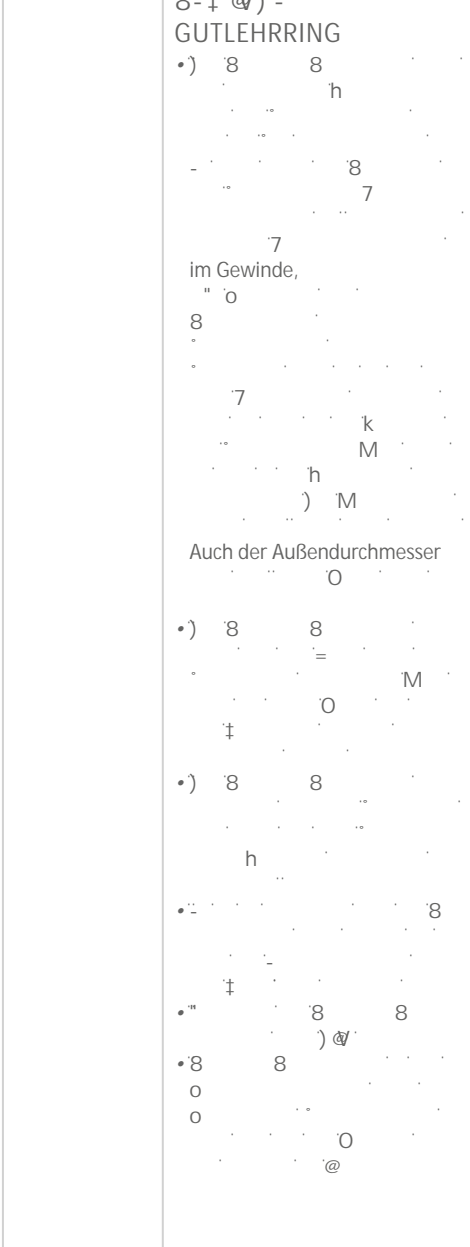
<p>8-† @) - GUTLEHRRING</p>  <p>im Gewinde,</p> <p>Auch der Außendurchmesser</p>	<p>GO THREAD RING GAUGE</p> <ul style="list-style-type: none"> The go thread ring gauge dimension of the external e.g. pitch and thread profile root does not extend too far major diameter is also not It must be possible to screw on the go thread ring gauge by hand along the full length of the use of particular force. The go thread ring gauge is subject to greater wear and plug gauge. It should be noted that the thread length is not less than Go thread ring gauges in the without dirt flute (external threads are easier to clean than internal threads prior to gauging). 	<p>BAGUE FILETÉE ENTRE</p> <p>pariement du filet extérieur et</p> <p>flanc qui est droite est suffi</p> <p>si le rayon du noyau du filet extérieur ne passe pas trop loin dans le flanc du profil. Par contre le rayon du</p> <ul style="list-style-type: none"> La bague filetée entre doit pou sur toute la longueur du file La bague filetée entre est expo sée à une usure plus forte rement au moyen du tampon Il faut noter que pour assurer filetée de la bague ne doit pas Les bagues filetées entre en rainure de nettoyage (il est plus facile nettoyer un filetage ex taraudage). 	<p>CALIBRO AD ANELLO FILETTATO PASSA</p> <ul style="list-style-type: none"> Il calibro ad anello filettato passa controlla la cosiddetta filettatura esterna e la possibilità anello. Controlla la misura massima del diametro medio della filetto. Inoltre il calibro ad anello controlla se la parte diritta del della filettatura esterna non passa troppo oltre nel fianco del profilo. Il raggio del nocciolo lato da questo calibro. Il calibro ad anello filettato manualmente su tutta la lung Il calibro ad anello filettato calibro a tampone per controllo Bisogna notare che per assi I calibri ad anello filettati passa facile pulire una filettatura esterna prima del controllo che una filettatura interna).
---	--	---	---

GEWINDELEHREN

Thread gauges / Calibres filetés / Calibri filettati

8-† ° Ø

<p>8-† Ø) - AUSSCHUSSLEHRRING</p> <p>•) 8</p> <p>@ † M)</p> <p>M</p> <p>•) 8</p> <p>M 8 † o y beim Abschrauben des Lehr</p> <p>•) 8</p> <p>•) 8</p> <p>8 8) 8</p> <p>7 •) 0 U •") Ø</p>	<p>V\ 8\ u=k- °) kØ8' GAUGE</p> <p>ü</p> <p>actual pitch diameter of the</p> <p>below the prescribed smallest</p> <p>and minor diameter are not tested here.</p> <p>• It must not be possible to screw</p> <p>(from both sides) by hand for more than two threads without the use of particular force. The</p> <p>on screwing off the ring gauge.</p> <p>ü</p> <p>must be monitored regularly</p> <p>gauge.</p> <p>ü</p> <p>has a thread length of at least three threads. The thread profile has a truncated crest.</p> <p>ü</p> <p>) Ø</p>	<p>BAGUE FILETÉE V - Vuk- 'h° o</p> <p>O</p> <p>flancs effectif du filet extérieur</p> <p>cote minimale prescrite. Le dia</p> <p>de noyau du filet extérieur ne</p> <p>O</p> <p>manuellement sur le filetage</p> <p>h</p> <p>sans forcer. Les deux tours sont</p> <p>bague.</p> <p>O</p> <p>O</p> <p>une longueur filetée de trois filets au moins. Le profil du filet est tronqué.</p> <p>• Les bagues ont un marquage rouge.</p> <p>) Ø</p>	<p>CALIBRO AD ANELLO FILETTATO NON PASSA</p> <p>• Il calibro ad anello filettato</p> <p>rimane inferiore alla misura minima prescritta. Il diametro esterno ed il diametro di nocciolo della filettatura esterna non sono controllati.</p> <p>• Il calibro ad anello filettato non</p> <p>ad anello.</p> <p>• Il calibro ad anello filettato non</p> <p>regolarmente con il calibro a</p> <p>• Il calibro ad anello filettato non</p> <p>ta di almeno tre filetti. Il profilo del filetto ha la cresta ridotta.</p> <p>• I calibri sono marcati con un anello rosso.</p> <p>) Ø</p>
--	--	---	---



SOLUTIONS@NORIS-REIME.DE

Das REIME Team steht Ihnen bei der Lösung Ihrer Zerspanungsaufgabe gerne zur Seite

The REIME team will be happy to solve your threading tasks

L'équipe de REIME se tient à votre disposition pour résoudre vos problèmes de filetage

Il team REIME sarà lieto di risolvere i vostri problemi di filettatura

UNSERE PRÄZISION IST IHR ERFOLG
OUR PRECISION IS YOUR SUCCESS

GEWINDETABELLEN

Threadtables

u

u



ANWENDUNGSKLASSEN M/MF

/#

/#

Anwendungsklasse des Gewindebohrers Application class of tap Classe d'utilisation du taraud Classe d'applicazione del maschiatore		Toleranz des Innengewindes Tolerance class of internal thread Classe de tolérance du filetage intérieur Classe di tolleranza del filetto interno					
ISO	DIN						
ISO 1	4H	4H	5H	-	-	-	-
ISO 2	6H	4G	5G	6H	-	-	-
ISO 3	6G	-	(4E)	6G	7H	8H	-
-	7G	-	-	(6E)	7G	8G	-

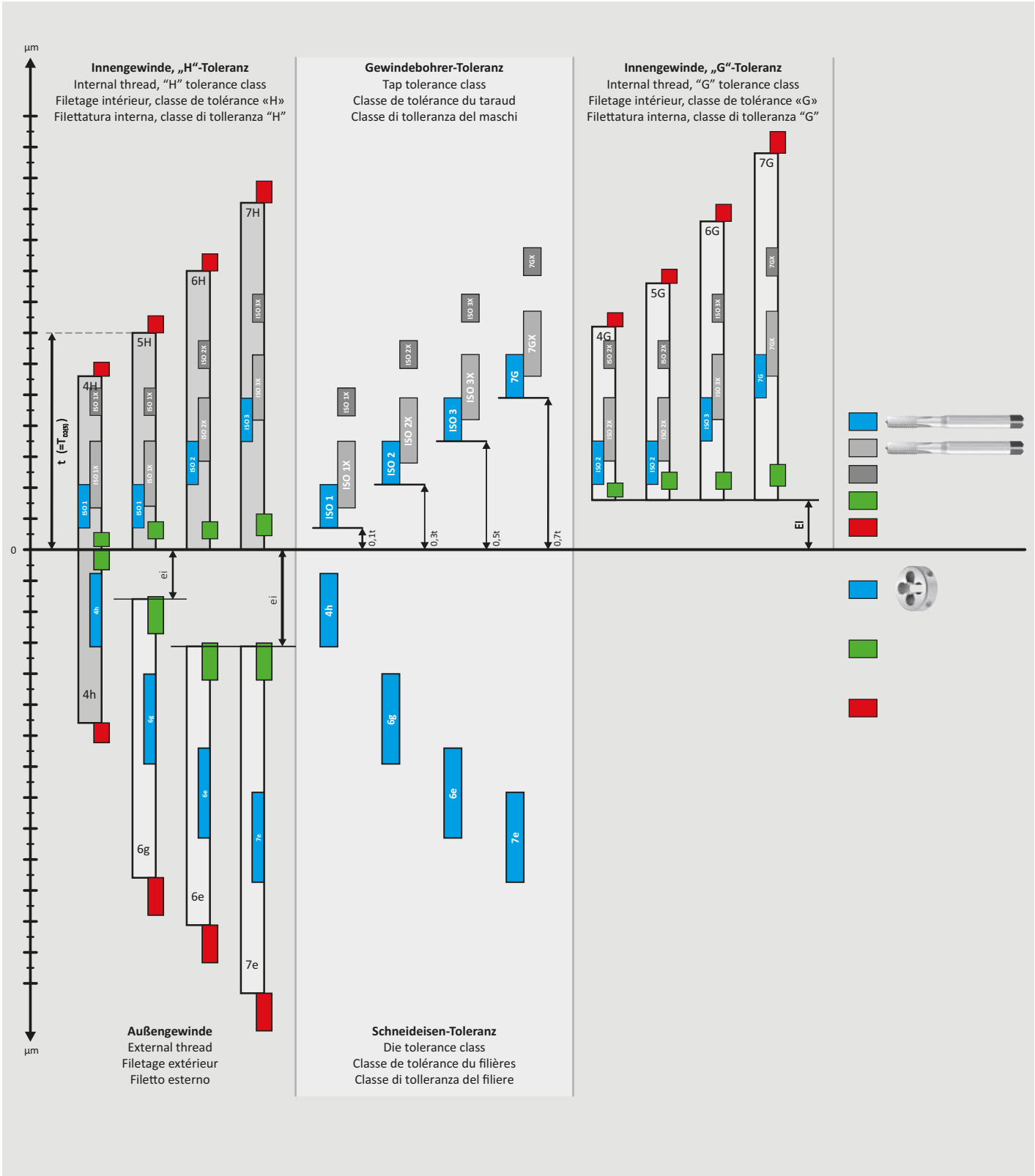

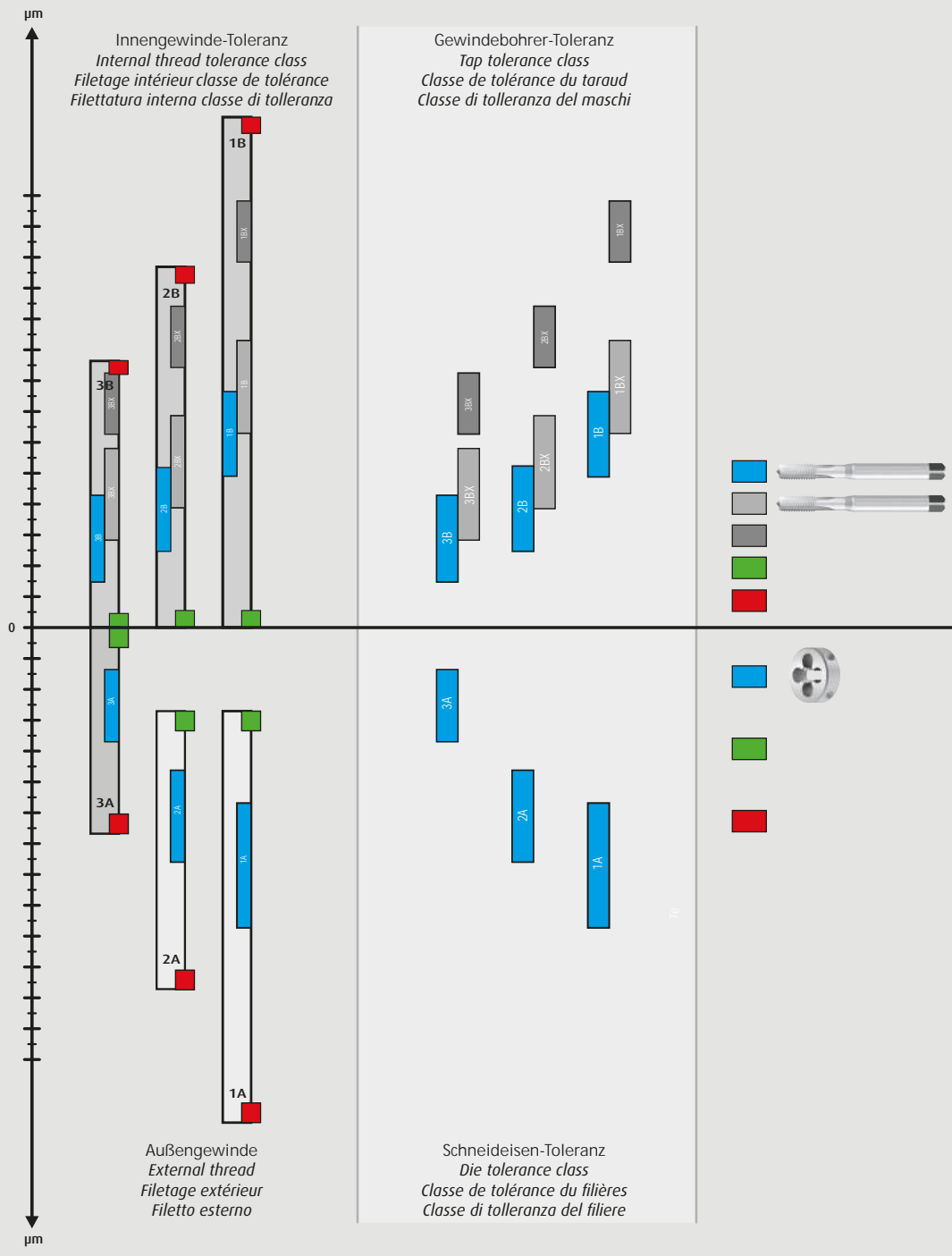

EMPFOHLENE HERSTELLTOLERANZEN

k / u / u

D		P	T _{D2(5)}	ISO 1			ISO 2			ISO 3			7G		
> mm	< mm			d ₂	d	d	d ₂	d	d	d ₂	d	d ₂	d		
				min.	max.	min.	min.	max.	min.	min.	max.	min.	min.	max.	min.
0,99	1,4	0,2	50	+5	+15	+15	-	-	-	-	-	-	-	-	-
0,99	1,4	0,25	56	+6	+17	+17	-	-	-	-	-	-	-	-	-
0,99	1,4	0,3	60	+6	+18	+18	+18	+30	+30	-	-	-	-	-	-
1,4	2,8	0,2	53	+5	+16	+16	-	-	-	-	-	-	-	-	-
1,4	2,8	0,25	60	+6	+18	+18	-	-	-	-	-	-	-	-	-
1,4	2,8	0,35	67	+7	+20	+20	+20	+34	+34	-	-	-	-	-	-
1,4	2,8	0,4	71	+7	+21	+21	+21	+36	+36	-	-	-	-	-	-
1,4	2,8	0,45	75	+8	+23	+23	+23	+38	+38	-	-	-	-	-	-
2,8	5,6	0,35	71	+7	+21	+21	+21	+36	+36	+36	+50	+50	+50	+64	+64
2,8	5,6	0,5	80	+8	+24	+24	+24	+40	+40	+40	+56	+56	+56	+72	+72
2,8	5,6	0,6	90	+9	+27	+27	+27	+45	+45	+45	+63	+63	+63	+81	+81
2,8	5,6	0,7	95	+10	+29	+29	+29	+48	+48	+48	+67	+67	+67	+86	+86
2,8	5,6	0,75	95	+10	+29	+29	+29	+48	+48	+48	+67	+67	+67	+86	+86
2,8	5,6	0,8	100	+10	+30	+30	+30	+50	+50	+50	+70	+70	+70	+90	+90
5,6	11,2	0,75	106	+11	+32	+32	+32	+53	+53	+53	+74	+74	+74	+95	+95
5,6	11,2	1	118	+12	+35	+35	+35	+59	+59	+59	+83	+83	+83	+106	+106
5,6	11,2	1,25	125	+13	+38	+38	+38	+63	+63	+63	+88	+88	+88	+113	+113
5,6	11,2	1,5	140	+14	+42	+42	+42	+70	+70	+70	+98	+98	+98	+126	+126
11,2	22,4	1	125	+13	+38	+38	+38	+63	+63	+63	+88	+88	+88	+113	+113
11,2	22,4	1,25	140	+14	+42	+42	+42	+70	+70	+70	+98	+98	+98	+126	+126
11,2	22,4	1,5	150	+15	+45	+45	+45	+75	+75	+75	+105	+105	+105	+135	+135
11,2	22,4	1,75	160	+16	+48	+48	+48	+80	+80	+80	+112	+112	+112	+144	+144
11,2	22,4	2	170	+17	+51	+51	+51	+85	+85	+85	+119	+119	+119	+153	+153
11,2	22,4	2,5	180	+18	+54	+54	+54	+90	+90	+90	+126	+126	+126	+162	+162
22,4	45	1	132	+13	+40	+40	+40	+66	+66	+66	+92	+92	+92	+119	+119
22,4	45	1,5	160	+16	+48	+48	+48	+80	+80	+80	+112	+112	+112	+144	+144
22,4	45	2	180	+18	+54	+54	+54	+90	+90	+90	+126	+126	+126	+162	+162
22,4	45	3	212	+21	+64	+64	+64	+106	+106	+106	+148	+148	+148	+191	+191
22,4	45	3,5	224	+22	+67	+67	+67	+112	+112	+112	+157	+157	+157	+202	+202
22,4	45	4	236	+24	+71	+71	+71	+118	+118	+118	+165	+165	+165	+212	+212
22,4	45	4,5	250	+25	+75	+75	+75	+125	+125	+125	+175	+175	+175	+225	+225
45	90	1,5	170	+17	+51	+51	+51	+85	+85	+85	+119	+119	+119	+153	+153
45	90	2	190	+19	+57	+57	+57	+95	+95	+95	+133	+133	+133	+171	+171
45	90	3	224	+22	+67	+67	+67	+112	+112	+112	+157	+157	+157	+202	+202
45	90	4	250	+25	+75	+75	+75	+125	+125	+125	+175	+175	+175	+225	+225
45	90	5	265	+27	+80	+80	+80	+133	+133	+133	+186	+186	+186	+239	+239
45	90	5,5	280	+28	+84	+84	+84	+140	+140	+140	+196	+196	+196	+252	+252
45	90	6	300	+30	+90	+90	+90	+150	+150	+150	+210	+210	+210	+270	+270
90	180	2	200	+20	+60	+60	+60	+100	+100	+100	+140	+140	+140	+180	+180
90	180	3	236	+24	+71	+71	+71	+118	+118	+118	+165	+165	+165	+212	+212
90	180	4	265	+27	+80	+80	+80	+133	+133	+133	+186	+186	+186	+239	+239
90	180	6	315	+32	+95	+95	+95	+158	+158	+158	+221	+221	+221	+284	+284
90	180	8	355	+36	+107	+107	+107	+178	+178	+178	+249	+249	+249	+320	+320

Δ - Änderung durch Beschichtung
 Δ - Change due to coating
 Δ - Modification du revêtement
 Δ - Cambio del passo grazie al rivestimento

$$\Delta = 2x \frac{t}{\sin\left(\frac{\alpha}{2}\right)}$$

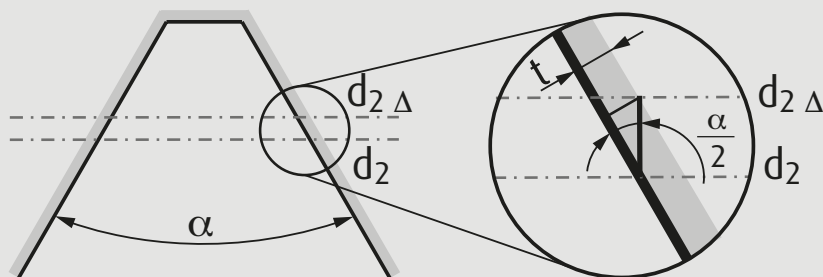

GEWINDE-TABELLEN

u

/u

/u

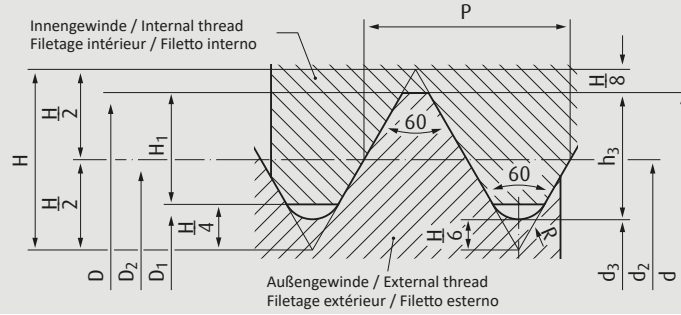

**U - uk@#=-o@ \ 8- † @) -
k-8-Ø- † @) -**
Grenzmaße – Innengewinde
DIN 13-20 (Auszug)
Toleranzfeld 4H, 5H, 6H, 7H

ISO METRIC THREADS
\ ° ko- u=k- °) o
Limit dimensions – Internal thread
DIN 13-20 (Excerpt)
Tolerance zone 4H, 5H, 6H, 7H

**7@ u' 8- U /uk@ y- @ \ °
7@ u' 8- ° h' o \ kU ° y@**
Dimensions limitee – Filetage intérieur
DIN 13-20 (Extrait)
Champ de tolérance 4H, 5H, 6H, 7H

**7@ uu' uyk ° @ \ U - uk@ ° °
7@ uu' uyk ° 8k \ oo°**
Dimensione, limite – Filettatura interna
DIN 13-20 (Estratto)
Campo di tolleranza 4H, 5H, 6H, 7H

Gewinde- Nenndurchm. Nominal thread diameter Diamètre nominal du filet Dia. nominale del filetto	Steigung Pitch Pas Passo	Außen- durchmesser Major diameter Diamètre extérieur Diametro esterno	Flankendurchmesser Pitch diameter Diamètre sur flanc Diametro medio					Kerndurchmesser Minor diameter Diamètre de noyau Diametro del nocciolo				
			D ₂ min.	D ₂ max.				D ₁ min.	D ₁ max.			
				4H	5H	6H	7H		4H	5H	6H	7H
M 1	0,25	1,000	0,838	0,883	0,894	-	-	0,729	0,774	0,785	-	-
M 1,1	0,25	1,100	0,938	0,983	0,994	-	-	0,829	0,874	0,885	-	-
M 1,2	0,25	1,200	1,038	1,083	1,094	-	-	0,929	0,974	0,985	-	-
M 1,4	0,3	1,400	1,205	1,253	1,265	1,280	-	1,075	1,128	1,142	1,160	-
M 1,6	0,35	1,600	1,373	1,426	1,440	1,458	-	1,221	1,284	1,301	1,321	-
M 1,8	0,35	1,800	1,573	1,626	1,640	1,658	-	1,421	1,484	1,501	1,521	-
M 2	0,4	2,000	1,740	1,796	1,811	1,830	-	1,567	1,638	1,657	1,679	-
M 2,2	0,45	2,200	1,908	1,968	1,983	2,003	-	1,713	1,793	1,813	1,838	-
M 2,5	0,45	2,500	2,208	2,268	2,283	2,303	-	2,013	2,093	2,113	2,138	-
M 3	0,5	3,000	2,675	2,738	2,755	2,775	2,800	2,459	2,549	2,571	2,599	2,639
M 3,5	0,6	3,500	3,110	3,181	3,200	3,222	3,250	2,850	2,950	2,975	3,010	3,050
M 4	0,7	4,000	3,545	3,620	3,640	3,663	3,695	3,242	3,354	3,382	3,422	3,466
M 4,5	0,75	4,500	4,013	4,088	4,108	4,131	4,163	3,688	3,806	3,838	3,878	3,924
M 5	0,8	5,000	4,480	4,560	4,580	4,605	4,640	4,134	4,259	4,294	4,334	4,384
M 6	1	6,000	5,350	5,445	5,468	5,500	5,540	4,917	5,067	5,107	5,153	5,217
M 7	1	7,000	6,350	6,445	6,468	6,500	6,540	5,917	6,067	6,107	6,153	6,217
M 8	1,25	8,000	7,188	7,288	7,313	7,348	7,388	6,647	6,817	6,859	6,912	6,982
M 9	1,25	9,000	8,188	8,288	8,313	8,348	8,388	7,647	7,817	7,859	7,912	7,982
M 10	1,5	10,000	9,026	9,138	9,166	9,206	9,250	8,376	8,566	8,612	8,676	8,751
M 11	1,5	11,000	10,026	10,138	10,166	10,206	10,250	9,376	9,566	9,612	9,676	9,751
M 12	1,75	12,000	10,863	10,988	11,023	11,063	11,113	10,106	10,318	10,371	10,441	10,531
M 14	2	14,000	12,701	12,833	12,871	12,913	12,966	11,835	12,071	12,135	12,210	12,310
M 16	2	16,000	14,701	14,833	14,871	14,913	14,966	13,835	14,071	14,135	14,210	14,310
M 18	2,5	18,000	16,376	16,516	16,556	16,600	16,656	15,294	15,574	15,649	15,744	15,854
M 20	2,5	20,000	18,376	18,516	18,556	18,600	18,656	17,294	17,574	17,649	17,744	17,854
M 22	2,5	22,000	20,376	20,516	20,556	20,600	20,656	19,294	19,574	19,649	19,744	19,854
M 24	3	24,000	22,051	22,221	22,263	22,316	22,386	20,752	21,067	21,152	21,252	21,382
M 27	3	27,000	25,051	25,221	25,263	25,316	25,386	23,752	24,067	24,152	24,252	24,382
M 30	3,5	30,000	27,727	27,907	27,951	28,007	28,082	26,211	26,566	26,661	26,771	26,921
M 33	3,5	33,000	30,727	30,907	30,951	31,007	31,082	29,211	29,566	29,661	29,771	29,921
M 36	4	36,000	33,402	33,592	33,638	33,702	33,777	31,670	32,045	32,145	32,270	32,420
M 39	4	39,000	36,402	36,592	36,638	36,702	36,777	34,670	35,045	35,145	35,270	35,420
M 42	4,5	42,000	39,077	39,277	39,327	39,392	39,477	37,129	37,554	37,659	37,799	37,979
M 45	4,5	45,000	42,077	42,277	42,327	42,392	42,477	40,129	40,554	40,659	40,799	40,979
M 48	5	48,000	44,752	44,964	45,017	45,087	45,177	42,587	43,037	43,147	43,297	43,487
M 52	5	52,000	48,752	48,964	49,017	49,087	49,177	46,587	47,037	47,147	47,297	47,487
M 56	5,5	56,000	52,428	52,652	52,708	52,783	52,878	50,046	50,521	50,646	50,796	50,996
M 60	5,5	60,000	56,428	56,652	56,708	56,783	56,878	54,046	54,521	54,646	54,796	54,996

GEWINDE-TABELLEN

u / u / u

METRISCHES

7-8-1-1) -

Grenzmaße – Innengewinde
DIN 13-21, 13-22, 13-23 (Auszug)
Toleranzfeld 4H, 5H, 6H, 7H

ISO METRIC FINE THREADS

Limit dimensions – Internal thread
DIN 13-21, 13-22, 13-23 (Excerpt)
Tolerance zone 4H, 5H, 6H, 7H

7-8-1-1) / uk y - 1) " h o 7

Dimensions limitees – Filetage intérieur
DIN 13-21, 13-22, 13-23 (Extrait)
Champ de tolérance 4H, 5H, 6H, 7H

7-11-1-1) 1) U - uk 1) " h o 1 7-1

Dimensione, limite – Filettatura interna
DIN 13-21, 13-22, 13-23 (Estratto)
Campo di tolleranza 4H, 5H, 6H, 7H

Gewinde- Nenndurchm. Nominal thread diameter Diamètre nominal du filet Dia. nominale del filetto	Steigung Pitch Pas Passo	Außen- durchmesser Major diameter Diamètre extérieur Diametro esterno	Flankendurchmesser					Kerndurchmesser				
			Pitch diameter					Minor diameter				
			Diamètre sur flanc					Diamètre de noyau				
D	P	D min.	D ₂ min.	D ₂ max.				D ₁ min.	D ₁ max.			
				4H	5H	6H	7H		4H	5H	6H	7H
M 2,5 x 0,35	0,35	2,500	2,273	2,326	2,340	2,358	-	2,121	2,184	2,201	2,221	-
M 3 x 0,35	0,35	3,000	2,773	2,829	2,844	2,863	-	2,621	2,684	2,701	2,721	-
M 3,5 x 0,35	0,35	3,500	3,273	3,329	3,344	3,363	-	3,121	3,184	3,201	3,221	-
M 4 x 0,35	0,35	4,000	3,773	3,829	3,844	3,863	-	3,621	3,684	3,701	3,721	-
M 4 x 0,5	0,5	4,000	3,675	3,738	3,755	3,775	3,800	3,459	3,549	3,571	3,599	3,639
M 4,5 x 0,5	0,5	4,500	4,175	4,238	4,255	4,275	4,300	3,959	4,049	4,071	4,099	4,139
M 5 x 0,5	0,5	5,000	4,675	4,738	4,755	4,775	4,800	4,459	4,549	4,571	4,599	4,639
M 6 x 0,5	0,5	6,000	5,675	5,746	5,765	5,787	-	5,459	5,549	5,571	5,599	5,639
M 6 x 0,75	0,75	6,000	5,513	5,598	5,619	5,645	5,683	5,188	5,306	5,338	5,378	5,424
M 7 x 0,75	0,75	7,000	6,513	6,598	6,619	6,645	6,683	6,188	6,306	6,338	6,378	6,424
M 8 x 0,5	0,5	8,000	7,675	7,746	7,765	7,787	-	7,459	7,549	7,571	7,599	7,639
M 8 x 0,75	0,75	8,000	7,513	7,598	7,619	7,645	7,683	7,188	7,306	7,338	7,378	7,424
M 8 x 1	1	8,000	7,350	7,445	7,468	7,500	7,540	6,917	7,067	7,107	7,153	7,217
M 9 x 1	1	9,000	8,350	8,445	8,468	8,500	8,540	7,917	8,067	8,107	8,153	8,217
M 10 x 0,75	0,75	10,000	9,513	9,598	9,619	9,645	9,683	9,188	9,306	9,338	9,378	9,424
M 10 x 1	1	10,000	9,350	9,445	9,468	9,500	9,540	8,917	9,067	9,107	9,153	9,217
M 10 x 1,25	1,25	10,000	9,188	9,288	9,313	9,348	9,388	8,647	8,817	8,859	8,912	8,982
M 11 x 1	1	11,000	10,350	10,445	10,468	10,500	10,540	9,917	10,067	10,107	10,153	10,217
M 12 x 1	1	12,000	11,350	11,450	11,475	11,510	11,550	10,917	11,067	11,107	11,153	11,217
M 12 x 1,25	1,25	12,000	11,188	11,300	11,328	11,368	11,412	10,647	10,817	10,859	10,912	10,982
M 12 x 1,5	1,5	12,000	11,026	11,144	11,176	11,216	11,262	10,376	10,566	10,612	10,676	10,751
M 13 x 1	1	13,000	12,350	12,450	12,475	12,510	12,550	11,917	12,067	12,107	12,153	12,217
M 14 x 1	1	14,000	13,350	13,450	13,475	13,510	13,550	12,917	13,067	13,107	13,153	13,217
M 14 x 1,25	1,25	14,000	13,188	13,300	13,328	13,368	13,412	12,647	12,817	12,859	12,912	12,982
M 14 x 1,5	1,5	14,000	13,026	13,144	13,176	13,216	13,262	12,376	12,566	12,612	12,676	12,751
M 15 x 1	1	15,000	14,350	14,450	14,475	14,510	14,550	13,917	14,068	14,108	14,154	14,218
M 15 x 1,5	1,5	15,000	14,026	14,144	14,176	14,216	14,262	13,376	13,566	13,612	13,676	13,751
M 16 x 1	1	16,000	15,350	15,450	15,475	15,510	15,550	14,918	15,068	15,108	15,154	15,218
M 16 x 1,5	1,5	16,000	15,026	15,144	15,176	15,216	15,262	14,376	14,566	14,612	14,676	14,751
M 18 x 1	1	18,000	17,350	17,450	17,475	17,510	17,550	16,918	17,068	17,108	17,154	17,218
M 18 x 1,5	1,5	18,000	17,026	17,144	17,176	17,216	17,262	16,376	16,566	16,612	16,676	16,751
M 18 x 2	2	18,000	16,701	16,833	16,871	16,913	16,966	15,835	16,071	16,135	16,210	16,310
M 20 x 1	1	20,000	19,350	19,450	19,475	19,510	19,550	18,918	19,068	19,108	19,154	19,218
M 20 x 1,5	1,5	20,000	19,026	19,144	19,176	19,216	19,262	18,376	18,566	18,612	18,676	18,751
M 20 x 2	2	20,000	18,701	18,833	18,871	18,913	18,966	17,835	18,071	18,135	18,210	18,310
M 22 x 1	1	22,000	21,350	21,450	21,475	21,510	21,550	20,918	21,068	21,108	21,154	21,218
M 22 x 1,5	1,5	22,000	21,026	21,144	21,176	21,216	21,262	20,376	20,566	20,612	20,676	20,751
M 22 x 2	2	22,000	20,701	20,833	20,871	20,913	20,966	19,835	20,071	20,135	20,210	20,310
M 24 x 1	1	24,000	23,350	23,456	23,482	23,520	23,562	22,918	23,068	23,108	23,154	23,218
M 24 x 1,5	1,5	24,000	23,026	23,151	23,186	23,226	23,276	22,376	22,566	22,612	22,676	22,751
M 24 x 2	2	24,000	22,701	22,841	22,881	22,925	22,981	21,835	22,071	22,135	22,210	22,310
M 25 x 1,5	1,5	25,000	24,026	24,151	24,186	24,226	24,276	23,376	23,566	23,612	23,676	23,751
M 26 x 1,5	1,5	26,000	25,026	25,151	25,186	25,226	25,276	24,376	24,566	24,612	24,676	24,751
M 27 x 1,5	1,5	27,000	26,026	26,151	26,186	26,226	26,276	25,376	25,566	25,612	25,676	25,751
M 27 x 2	2	27,000	25,701	25,841	25,881	25,925	25,981	24,835	25,071	25,135	25,210	25,310
M 28 x 1,5	1,5	28,000	27,026	27,151	27,186	27,226	27,276	26,376	26,566	26,612	26,676	26,751
M 30 x 1	1	30,000	29,350	29,456	29,482	29,520	29,562	28,918	29,068	29,108	29,154	29,218
M 30 x 1,5	1,5	30,000	29,026	29,151	29,186	29,226	29,276	28,376	28,566	28,612	28,676	28,751
M 30 x 2	2	30,000	28,701	28,841	28,881	28,925	28,981	27,835	28,071	28,135	28,210	28,310

u / u / u

GEWINDE-TABELLEN

u

/u

/u

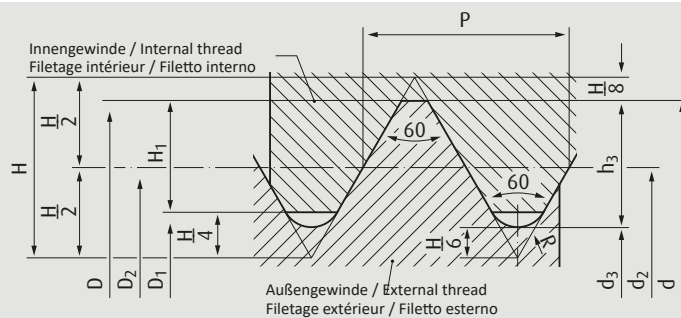

Gewinde- Nennndurchm. Nominal thread diameter Diamètre nominal du filet Dia. nominale del filetto	Steigung Pitch Pas Passo	Außen- durchmesser Major diameter Diamètre extérieur Diametro esterno	Flankendurchmesser					Kerndurchmesser				
			Pitch diameter					Minor diameter				
			Diamètre sur flanc					Diamètre de noyau				
			Diametro medio					Diametro del nocciolo				
D	P	D min.	D ₂ min.	D ₂ max.				D ₁ min.	D ₁ max.			
				4H	5H	6H	7H		4H	5H	6H	7H
M 32 x 1,5	1,5	32,000	31,026	31,151	31,186	31,226	31,276	30,376	30,566	30,612	30,676	30,751
M 33 x 1,5	1,5	33,000	32,026	32,151	32,186	32,226	32,276	31,376	31,566	31,612	31,676	31,751
M 33 x 2	2	33,000	31,701	31,841	31,881	31,925	31,981	30,835	31,071	31,135	31,210	31,310
M 34 x 1,5	1,5	34,000	33,026	33,151	33,186	33,226	33,276	32,376	32,566	32,612	32,676	32,751
M 35 x 1,5	1,5	35,000	34,026	34,151	34,186	34,226	34,276	33,376	33,566	33,612	33,676	33,751
M 36 x 1,5	1,5	36,000	35,026	35,151	35,186	35,226	35,276	34,376	34,566	34,612	34,676	34,751
M 36 x 2	2	36,000	34,701	34,841	34,881	34,925	34,981	33,835	34,071	34,135	34,210	34,310
M 36 x 3	3	36,000	34,051	34,221	34,263	34,316	34,386	32,753	33,068	33,153	33,253	33,383
M 38 x 1,5	1,5	38,000	37,026	37,151	37,186	37,226	37,276	36,376	36,566	36,612	36,676	36,751
M 39 x 2	2	39,000	37,701	37,841	37,881	37,925	37,981	36,835	37,071	37,135	37,210	37,310
M 39 x 3	3	39,000	37,051	37,221	37,263	37,316	37,386	35,753	36,068	36,153	36,253	36,383
M 40 x 1,5	1,5	40,000	39,026	39,151	39,186	39,226	39,276	38,376	38,566	38,612	38,676	38,751
M 40 x 2	2	40,000	38,701	38,841	38,881	38,925	38,981	37,835	38,071	38,135	38,210	38,310
M 40 x 3	3	40,000	38,051	38,221	38,263	38,316	38,386	36,753	37,068	37,153	37,253	37,383
M 42 x 1,5	1,5	42,000	41,026	41,151	41,186	41,226	41,276	40,376	40,566	40,612	40,676	40,751
M 42 x 2	2	42,000	40,701	40,841	40,881	40,925	40,981	39,835	40,071	40,135	40,210	40,310
M 42 x 3	3	42,000	40,051	40,221	40,263	40,316	40,386	38,753	39,068	39,153	39,253	39,383
M 45 x 1,5	1,5	45,000	44,026	44,151	44,186	44,226	44,276	43,376	43,566	43,612	43,676	43,751
M 45 x 2	2	45,000	43,701	43,841	43,881	43,925	43,981	42,835	43,071	43,135	43,210	43,310
M 45 x 3	3	45,000	43,051	43,221	43,263	43,316	43,386	41,752	42,067	42,152	42,252	42,382
M 48 x 1,5	1,5	48,000	47,026	47,151	47,186	47,226	47,276	46,376	46,566	46,612	46,676	46,751
M 48 x 2	2	48,000	46,701	46,841	46,881	46,925	46,981	45,835	46,071	46,135	46,210	46,310
M 48 x 3	3	48,000	46,051	46,221	46,263	46,316	46,386	44,752	45,067	45,152	45,252	45,382
M 50 x 1,5	1,5	50,000	49,026	49,151	49,186	49,226	49,276	48,376	48,566	48,612	48,676	48,751
M 50 x 2	2	50,000	48,701	48,841	48,881	48,925	48,981	47,835	48,071	48,135	48,210	48,310
M 50 x 3	3	50,000	48,051	48,231	48,275	48,331	48,406	46,752	47,067	47,152	47,252	47,382
M 52 x 1,5	1,5	52,000	51,026	51,151	51,186	51,226	51,276	50,376	50,566	50,612	50,676	50,751
M 52 x 2	2	52,000	50,701	50,851	50,891	50,937	51,001	49,835	50,071	50,135	50,210	50,310
M 52 x 3	3	52,000	50,051	50,231	50,275	50,331	50,406	48,753	49,068	49,153	49,253	49,383
M 56 x 2	2	56,000	54,701	54,851	54,891	54,937	55,001	53,835	54,071	54,135	54,210	54,310
M 56 x 3	3	56,000	54,051	54,231	54,275	54,331	54,406	52,753	53,068	53,153	53,253	53,383
M 56 x 4	4	56,000	53,402	53,602	53,652	53,717	53,802	51,670	52,045	52,145	52,270	52,420
M 60 x 4	4	60,000	57,402	57,602	57,652	57,717	57,802	55,670	56,045	56,145	56,270	56,420
M 64 x 3	3	64,000	62,051	62,231	62,275	62,331	62,406	60,753	61,068	61,153	61,253	61,383
M 64 x 4	4	64,000	61,402	61,602	61,652	61,717	61,802	59,670	60,045	60,145	60,270	60,420
M 68 x 4	4	68,000	65,402	65,602	65,652	65,717	65,802	63,670	64,045	64,145	64,270	64,420
M 72 x 3	3	72,000	70,051	70,231	70,275	70,331	70,406	68,753	69,068	69,153	69,253	69,383
M 72 x 4	4	72,000	69,402	69,602	69,652	69,717	69,802	67,670	68,045	68,145	68,270	68,420
M 72 x 6	6	72,000	68,103	68,339	68,403	68,478	68,578	65,505	66,005	66,135	66,305	66,505
M 76 x 3	3	76,000	74,051	74,231	74,275	74,331	74,406	72,753	73,068	73,153	73,253	73,383
M 76 x 4	4	76,000	73,402	73,602	73,652	73,717	73,802	71,670	72,045	72,145	72,270	72,420
M 76 x 6	6	76,000	72,103	72,339	72,403	72,478	72,578	69,505	70,005	70,135	70,305	70,505
M 80 x 2	2	80,000	78,701	78,851	78,891	78,937	79,001	77,835	78,071	78,135	78,210	78,310
M 80 x 4	4	80,000	77,402	77,602	77,652	77,717	77,802	75,670	76,045	76,145	76,270	76,420
M 80 x 6	6	80,000	76,103	76,339	76,403	76,478	76,578	73,505	74,005	74,135	74,305	74,505
M 85 x 4	4	85,000	82,402	82,602	82,652	82,717	82,802	80,670	81,045	81,145	81,270	81,420
M 85 x 6	6	85,000	81,103	81,339	81,403	81,478	81,578	78,505	79,005	79,135	79,305	79,505
M 90 x 4	4	90,000	87,402	87,602	87,652	87,717	87,802	85,670	86,045	86,145	86,270	86,420
M 90 x 6	6	90,000	86,103	86,339	86,403	86,478	86,578	83,505	84,005	84,135	84,305	84,505

GEWINDE-TABELLEN

u / u / u

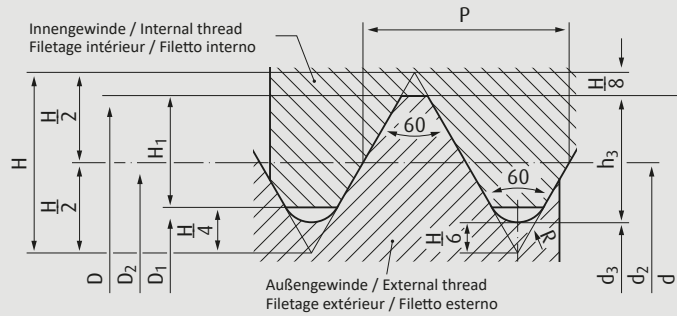

yV@) '8k\ "8-† @) - yV#

Grenzmaße – Innengewinde
ASME-B1.1 (Auszug)
Toleranzfeld 1B, 2B, 3B

UNIFIED COARSE THREADS UNC

Limit dimensions – Internal thread
ASME-B1.1 (Excerpt)
Tolerance zone 1B, 2B, 3B

7@u' 8- ° U/k@° @' UNIFIED UNC

Dimensions limitee – Filettatura interieur
ASME-B1.1 (Extrait)
Champ de tolérance 1B, 2B, 3B

7@uu' uyk° yV@) ° ° h° oo\ '8k\ oo\ yV#

Dimensione, limite – Filettatura interna
ASME-B1.1 (Estratto)
Campo di tolleranza 1B, 2B, 3B

Gewinde-Nenndurchm. Nominal thread diameter Diamètre nominal du filet Dia. nominale del filetto	Steigung Pitch Pas Passo	Außen-durchmesser Major diameter Diamètre extérieur Diametro esterno	Flankendurchmesser Pitch diameter Diamètre sur flanc Diametro medio				Kerndurchmesser Minor diameter Diamètre de noyau Diametro del nocciolo		
			D ₂ min.	D ₂ max.			D ₁ min.	D ₁ max.	
				3B	2B	1B		3B	2B, 1B
Nr. 1 - 64	0,397	1,854	1,598	1,646	1,664	-	1,425	1,582	1,582
Nr. 2 - 56	0,454	2,184	1,890	1,943	1,961	-	1,694	1,872	1,872
Nr. 3 - 48	0,529	2,515	2,172	2,228	2,248	-	1,941	2,146	2,146
Nr. 4 - 40	0,635	2,845	2,433	2,494	2,517	-	2,156	2,385	2,385
Nr. 5 - 40	0,635	3,175	2,764	2,827	2,847	-	2,487	2,697	2,697
Nr. 6 - 32	0,794	3,505	2,990	3,058	3,084	-	2,647	2,896	2,896
Nr. 8 - 32	0,794	4,166	3,650	3,721	3,746	-	3,307	3,528	3,531
Nr. 10 - 24	1,058	4,826	4,138	4,219	4,247	-	3,680	3,950	3,962
Nr. 12 - 24	1,058	5,486	4,798	4,882	4,910	-	4,341	4,590	4,597
1/4 - 20	1,27	6,350	5,524	5,616	5,648	5,710	4,976	5,250	5,258
5/16 - 18	1,411	7,938	7,021	7,120	7,155	7,221	6,411	6,680	6,731
3/8 - 16	1,588	9,525	8,494	8,603	8,639	8,710	7,805	8,082	8,153
7/16 - 14	1,814	11,112	9,934	10,051	10,089	10,168	9,149	9,441	9,550
1/2 - 13	1,954	12,700	11,430	11,552	11,595	11,676	10,584	10,881	11,024
9/16 - 12	2,117	14,288	12,913	13,043	13,086	13,172	11,996	12,301	12,446
5/8 - 11	2,309	15,875	14,376	14,514	14,559	14,648	13,376	13,693	13,868
3/4 - 10	2,54	19,050	17,399	17,544	17,595	17,691	16,299	16,624	16,840
7/8 - 9	2,822	22,225	20,391	20,546	20,599	20,703	19,169	19,520	19,761
1 - 8	3,175	25,400	23,338	23,505	23,561	23,673	21,963	22,344	22,606
1 1/8 - 7	3,629	28,575	26,218	26,398	26,457	26,576	24,648	25,082	25,349
1 1/4 - 7	3,629	31,750	29,393	29,576	29,637	29,759	27,823	28,258	28,524
1 3/8 - 6	4,233	34,925	32,174	32,372	32,438	32,568	30,343	30,851	31,115
1 1/2 - 6	4,233	38,100	35,349	35,550	35,616	35,750	33,518	34,026	34,290
1 3/4 - 5	5,08	44,450	41,151	41,372	41,445	41,592	38,951	39,560	39,827
2 - 4,5	5,645	50,800	47,135	47,371	47,450	47,607	44,689	45,367	45,593

GEWINDE-TABELLEN

u

/u

/u

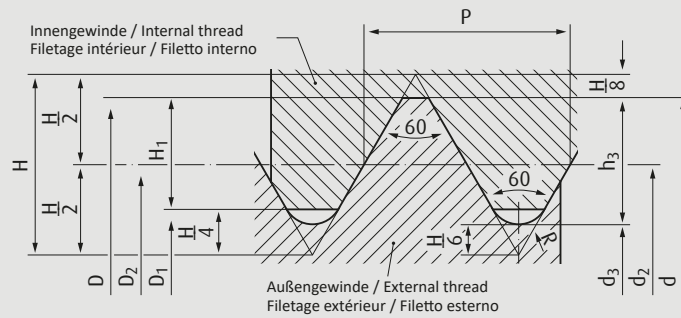

yV@) '7-@8-† @) - yV7

Grenzmaße – Innengewinde
ASME-B1.1 (Auszug)
Toleranzfeld 1B, 2B, 3B

UNIFIED FINE THREADS UNF

Limit dimensions – Internal thread
ASME-B1.1 (Excerpt)
Tolerance zone 1B, 2B, 3B

7@u° 8-° U/k@° @° h° o° FIN UNIFIED UNF

Dimensions limitee – Filetage intérieur
ASME-B1.1 (Extrait)
Champ de tolérance 1B, 2B, 3B

7@u° uyk° yV@) ° ° h° o° 7@- yV7

Dimensione, limite – Filettatura interna
ASME-B1.1 (Estratto)
Campo di tolleranza 1B, 2B, 3B

Gewinde-Nenndurchm. Nominal thread diameter Diamètre nominal du filet Dia. nominale del filetto	Steigung Pitch Pas Passo	Außendurchmesser Major diameter Diamètre extérieur Diametro esterno	Flankendurchmesser Pitch diameter Diamètre sur flanc Diametro medio				Kerndurchmesser Minor diameter Diamètre de noyau Diametro del nocciolo		
			D ₂ min.	D ₂ max.			D ₁ min.	D ₁ max.	
				3B	2B	1B		3B	2B, 1B
Nr. 1 - 72	0,353	1,854	1,626	1,674	1,689	-	1,473	1,613	1,613
Nr. 2 - 64	0,397	2,184	1,928	1,979	1,996	-	1,755	1,913	1,913
Nr. 3 - 56	0,454	2,515	2,220	2,273	2,291	-	2,024	2,197	2,197
Nr. 4 - 48	0,529	2,845	2,502	2,560	2,581	-	2,271	2,459	2,459
Nr. 5 - 44	0,577	3,175	2,799	2,860	2,880	-	2,550	2,741	2,741
Nr. 6 - 40	0,635	3,505	3,094	3,157	3,180	-	2,817	3,012	3,023
Nr. 8 - 36	0,706	4,166	3,708	3,777	3,800	-	3,401	3,597	3,607
Nr. 10 - 32	0,794	4,826	4,310	4,384	4,409	-	3,967	4,168	4,168
Nr. 12 - 28	0,907	5,486	4,897	4,976	5,004	-	4,503	4,717	4,724
1/4 - 28	0,907	6,350	5,761	5,842	5,870	5,926	5,367	5,563	5,588
5/16 - 24	1,058	7,938	7,249	7,341	7,371	7,430	6,792	6,995	7,036
3/8 - 24	1,058	9,525	8,837	8,931	8,961	9,025	8,379	8,565	8,636
7/16 - 20	1,27	11,112	10,287	10,391	10,424	10,493	9,738	9,947	10,033
1/2 - 20	1,27	12,700	11,874	11,981	12,017	12,088	11,326	11,524	11,608
9/16 - 18	1,411	14,288	13,371	13,482	13,520	13,597	12,761	12,969	13,081
5/8 - 18	1,411	15,875	14,958	15,072	15,110	15,189	14,348	14,554	14,681
3/4 - 16	1,588	19,050	18,019	18,143	18,184	18,268	17,330	17,546	17,678
7/8 - 14	1,814	22,225	21,046	21,181	21,224	21,316	20,262	20,493	20,676
1 - 12	2,117	25,400	24,026	24,171	24,219	24,315	23,109	23,363	23,571
1 1/8 - 12	2,117	28,575	27,201	27,351	27,399	27,498	26,284	26,538	26,746
1 1/4 - 12	2,117	31,750	30,376	30,528	30,579	30,681	29,459	29,713	29,921
1 3/8 - 12	2,117	34,925	33,551	33,706	33,759	33,863	32,634	32,888	33,096
1 1/2 - 12	2,117	38,100	36,726	36,886	36,937	37,043	35,809	36,063	36,271

GEWINDE-TABELLEN

u

/u

/u

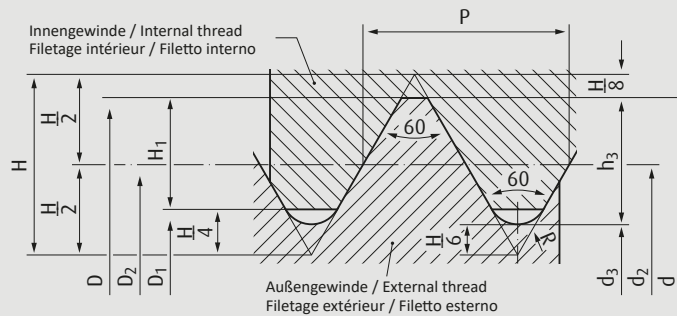

7-8-7 yV-7
Grenzmaße – Innengewinde
ASME-B1.1 (Auszug)
Toleranzfeld 2B, 3B

7-8-7 yV-7
Limit dimensions – Internal thread
ASME-B1.1 (Excerpt)
Tolerance zone 2B, 3B

7-8-7 U/k# 7 yV-7
Dimensions limitees – Filetage intérieur
ASME-B1.1 (Extrait)
Champ de tolérance 2B, 3B

7-8-7 yV-7
Dimensione, limite – Filettatura interna
ASME-B1.1 (Estratto)
Campo di tolleranza 2B, 3B

Gewinde-Nenndurchm. Nominal thread diameter Diamètre nominal du filet Dia. nominale del filetto	Steigung Pitch Pas Passo	Außendurchmesser Major diameter Diamètre extérieur Diametro esterno	Flankendurchmesser Pitch diameter Diamètre sur flanc Diametro medio			Kerndurchmesser Minor diameter Diamètre de noyau Diametro del nocciolo		
			D ₂ min.	D ₂ max.		D ₁ min.	D ₁ max.	
				3B	2B		3B	2B
Nr. 12 - 32	0,794	5,486	4,971	5,050	5,075	4,628	4,813	4,826
1/4 - 32	0,794	6,350	5,834	5,913	5,941	5,491	5,662	5,690
5/16 - 32	0,794	7,938	7,422	7,501	7,529	7,079	7,231	7,264
3/8 - 32	0,794	9,525	9,009	9,093	9,121	8,666	8,811	8,865
7/16 - 28	0,907	11,112	10,523	10,612	10,640	10,130	10,290	10,338
1/2 - 28	0,907	12,700	12,111	12,202	12,233	11,717	11,877	11,938
9/16 - 24	1,058	14,288	13,599	13,696	13,729	13,142	13,320	13,386
5/8 - 24	1,058	15,875	15,187	15,286	15,319	14,729	14,907	14,986
3/4 - 20	1,27	19,050	18,224	18,334	18,369	17,676	17,874	17,958
7/8 - 20	1,27	22,225	21,400	21,509	21,544	20,851	21,049	21,133
1 - 20	1,27	25,400	24,574	24,686	24,724	24,026	24,224	24,308

VERGLEICHSTABELLE INCH - MM

Steigung in Gang pro inch

h $\text{④}\# = \frac{UU}{u}$ / $\frac{u}{8}$ $\text{④}\# = \frac{UU}{u}$ / $\frac{u}{h}$ $\text{④}\# = \frac{UU}{u}$

Nennmaß Nominal size Dimension nominal Dimensione nominale inch / Nr.	Nenndurchm. Nominal diameter Diamètre nominal Diametro nominale ≈ [mm]	UNC	UNF	UNEF	UN-4	UN-6	UN-8	UN-12	UN-16	UN-20	UN-28	UN-32	W (BSW)	BSF	G Rp	Nenndurchm. Nominal diameter Diamètre nominal Diametro nominale [mm]
Nr. 0	1,52		80													
1/16	1,59												60		28	7,72
Nr. 1	1,85	64	72													
Nr. 2	2,18	56	64													
3/32	2,38												48			
Nr. 3	2,51	48	56													
Nr. 4	2,84	40	48													
Nr. 5	3,17	40	44													
1/8	3,17												40		28	9,72
Nr. 6	3,50	32	40													
5/32	3,96												32			
Nr. 8	4,16	32	36													
3/16	4,76												24	32		
Nr. 10	4,82	24	32													
Nr. 12	5,48	24	28	32												
7/32	5,55												24	28		
1/4	6,35	20	28	32									20	26	19	13,15
9/32	7,14													26		
5/16	7,93	18	24	32						20	28					
3/8	9,52	16	24	32						20	28		16	20	19	16,66
7/16	11,11	14	20	28					16			32	14	18		
1/2	12,70	13	20	28					16			32	12	16	14	20,95
9/16	14,28	12	18	24					16	20	28	32	12	16		
5/8	15,87	11	18	24				12	16	20	28	32	11	14	14	22,91
11/16	17,46			24				12	16	20	28	32		14		
3/4	19,05	10	16	20				12	16		28	32	10	12	14	26,44
13/16	20,64			20				12	16		28	32		12		
7/8	22,22	9	14	20				12	16		28	32	9	11	14	30,20
15/16	23,81			20				12	16		28	32				
1	25,40	8	12	20				16	16		28	32	8	10	11	33,24
1 1/16	26,99			18			8	12	16	20	28					
1 1/8	28,57	7	12	18			8	12	16	20	28		7	9	11	37,89
1 3/16	30,16			18			8	12	16	20	28					
1 1/4	31,75	7	12	18			8	12	16	20	28		7	9	11	41,91
1 5/16	33,34			18			8	12	16	20	28					
1 3/8	34,92	6	12	18			8	12	16	20	28		6	8	11	44,32
1 7/16	36,51			18	6	8	12	16	20	28						
1 1/2	38,10	6	12	18			8	12	16	20	28		6	8	11	47,80
1 9/16	39,69			18	6	8	12	16	20							
1 5/8	41,28			18	6	8	12	16	20				5	8		
1 11/16	42,86			18	6	8	12	16	20							
1 3/4	44,45	5			6	8	12	16	20				5	7	11	53,74
1 13/16	46,04				6	8	12	16	20							
1 7/8	47,63				6	8	12	16	20				4 1/2			
1 15/16	49,21				6	8	12	16	20							
2	50,80	4 1/2			6	8	12	16	20				4 1/2	7	11	59,61
2 1/8	53,97				6	8	12	16	20							
2 1/4	57,15	4 1/2			6	8	12	16	20				4	6	11	65,71
2 3/8	60,32				6	8	12	16	20							
2 1/2	63,50	4			6	8	12	16	20				4	6	11	75,18
2 5/8	66,67			4	6	8	12	16	20							
2 3/4	69,85	4			6	8	12	16	20				3 1/2	6	11	81,53
2 7/8	73,02			4	6	8	12	16	20							
3	76,20	4			6	8	12	16	20				3 1/2	5	11	87,88
3 1/8	79,37			4	6	8	12	16								
3 1/4	82,55	4			6	8	12	16					3 1/4	5	11	93,98
3 3/8	85,72			4	6	8	12	16								
3 1/2	88,90	4			6	8	12	16					3 1/4	4 1/2	11	100,33
3 5/8	92,07			4	6	8	12	16								
3 3/4	95,25	4			6	8	12	16					3	4 1/2	11	106,68
3 7/8	98,42			4	6	8	12	16								
4	101,60	4			6	8	12	16					3	4 1/2	11	113,03

GEWINDE-TABELLEN

u / u / u

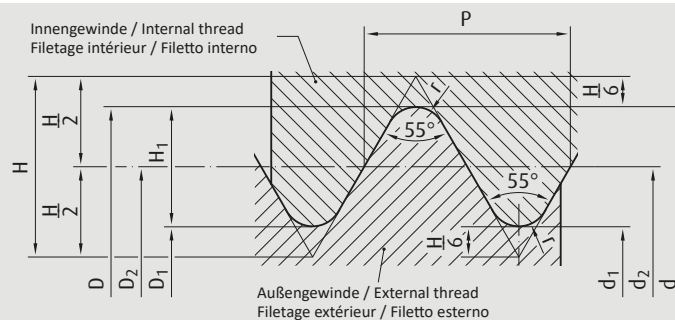

$\ddagger = @\ddagger \backslash ku=$
 $k \backslash k8-\ddagger @) - '8$
 Grenzmaße – Innengewinde
 DIN EN ISO 228 (Auszug)

$\ddagger = @\ddagger \backslash ku= 'h @-$
 $u=k-) '8$
 Limit dimensions – Internal thread
 DIN EN ISO 228 (Excerpt)

$7 @ u ' 8- 'h ' o) y ' 8 ' -$
 $\ddagger = @\ddagger \backslash ku= '8$
 Dimensions limitees – Filetage intérieu
 DIN EN ISO 228 (Extrait)

$7 @ uu' uyk ' 8 ' o$
 $\# @ @) k @ ' \ddagger = @\ddagger \backslash ku= '8$
 Dimensione, limite – Filettatura interna
 DIN EN ISO 228 (Estratto)

Gewinde- Nenndurchm. Nominal thread diameter Diamètre nominal du filet Dia. nominale del filetto	Steigung Pitch Pas Passo	Außen- durchmesser Major diameter Diamètre extérieur Diametro esterno	Flankendurchmesser Pitch diameter Diamètre sur flanc Diametro medio		Kerndurchmesser Minor diameter Diamètre de noyau Diametro del nocciolo	
			D_2 min.	D_2 max.	D_1 min.	D_1 max.
G $1/16$ - 28	0,907	7,723	7,142	7,249	6,561	6,843
G $1/8$ - 28	0,907	9,728	9,147	9,254	8,566	8,848
G $1/4$ - 19	1,337	13,157	12,301	12,426	11,445	11,89
G $3/8$ - 19	1,337	16,662	15,806	15,931	14,950	15,395
G $1/2$ - 14	1,814	20,955	19,793	19,935	18,631	19,172
G $5/8$ - 14	1,814	22,911	21,749	21,891	20,587	21,128
G $3/4$ - 14	1,814	26,441	25,279	25,421	24,117	24,658
G $7/8$ - 14	1,814	30,201	29,039	29,181	27,877	28,418
G 1" - 11	2,309	33,249	31,770	31,95	30,291	30,931
G $1 1/8$ - 11	2,309	37,897	36,418	36,598	34,939	35,579
G $1 1/4$ - 11	2,309	41,910	40,431	40,611	38,952	39,592
G $1 1/2$ - 11	2,309	47,803	46,324	46,504	44,845	45,485
G $1 3/4$ - 11	2,309	53,746	52,267	52,447	50,788	51,428
G 2" - 11	2,309	59,614	58,135	58,315	56,656	57,296

GEWINDE-KERNLOCHDURCHMESSER FÜR KEGELIGES ROHRGEWINDE NPT, KEGEL 1:16

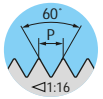

° V₀₀@ dJ - " "

REIME NPT-Gewindebohrer sind für die Lochformen A bis C geeignet. Für Gewinde mit höheren Anforderungen, z.B. NPT-Gewinde für die Luftfahrt, empfehlen wir, das Kernloch nach Form B bzw. C auszuführen

REIME NPT taps are suited for the hole forms A to C. For threads with higher demands, e.g. NPT threads for the aircraft industry, we recommend preparing the thread hole to form B, resp. C.

Les tarauds NPT d'REIME sont appropriés pour les formes A, B et C. Pour taraudages destinés à de hautes exigences techniques, p.ex. le filetage NPT pour l'industrie aéronautique, nous recommandons de percer l'avant-trou selon forme B ou C.

I maschi NPT REIME sono appropriati per le forme di foro A fino a C. Per filettature per elevate esigenze, p.es. filettature NPT per l'aviazione, raccomandiamo realizzare il preforo secondo forma B o C.

A

Zylindrisch vorbohren ohne Verwendung einer Reibahle
Drill cylindrically without using a reamer
Perçage cylindrique sans utilisation d'alésoir
Perforare cilindrico senza l'utilizzo di alesatore

Nenngröße.
Nom. size
Taille nom.
Grand. nom.

Steigung
Pitch
Pas
Passo

$\varnothing d_1$

$\varnothing D_1$

$t_1^{1)}$

$t_{4 \text{ Bohren}}^{1)}$

$t_{4 \text{ Fräsen}}$

Gg/1" (tpi)

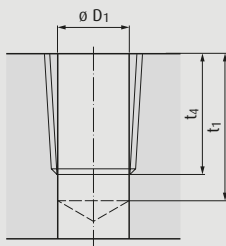

1/16	27	6,15	11,8	9,7	8,3
1/8	27	8,5	11,9	9,75	8,3
1/4	18	11	17,4	14,25	12,15
3/8	18	14,4	17,7	14,55	12,45
1/2	14	17,8	23,1	19	16,3
3/4	14	23,15	23,6	19,5	16,3
1"	11 1/2	29,05	28,4	23,4	19,55
1 1/4	11 1/2	37,8	28,9	23,9	20,05
1 1/2	11 1/2	43,85	28,9	23,9	20,05
2"	11 1/2	55,85	29,3	24,35	20,45

B

Zylindrisch vorbohren und kegelig aufreiben
Drill cylindrically and prepare tapered hole with reamer
Perçage cylindrique et alésage conique
Perforare cilindrico alesare conico

Nenngröße.
Nom. size
Taille nom.
Grand. nom.

Steigung
Pitch
Pas
Passo

$\varnothing d_1$

$\varnothing D_2$

$\varnothing D_3$

$t_1^{1)}$

$t_{4 \text{ Bohren}}^{1)}$

$t_{4 \text{ Fräsen}}$

Gg/1" (tpi)

(+0,05)

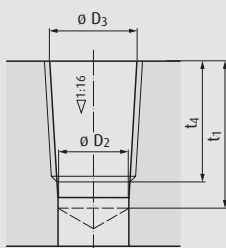

1/16	27	5,95	6,39	11,8	9,7	8,3
1/8	27	8,3	8,74	11,9	9,75	8,3
1/4	18	10,75	11,36	17,4	14,25	12,15
3/8	18	14,15	14,80	17,7	14,55	12,45
1/2	14	17,45	18,32	23,1	19	16,3
3/4	14	22,8	23,67	23,6	19,5	16,3
1"	11 1/2	28,65	29,69	28,4	23,4	19,55
1 1/4	11 1/2	37,35	38,45	28,9	23,9	20,05
1 1/2	11 1/2	43,45	44,52	28,9	23,9	20,05
2"	11 1/2	55,45	56,56	29,3	24,35	20,45

1) Die Vorbohrtiefe t_1 berücksichtigt die Längen L_1 und L_3 nach ASME-Norm, sowie die Anschnittlänge des Gewindebohrers und 1 bis 2 Gewindegänge Sicherheit. Tiefbohren ist erforderlich, wenn Gewindebohrer mit Maximal-Gewindelängen nach ASME B94.9 angewendet werden sollen.

1) The drill depth t_1 takes into account the lengths L_1 and L_3 acc. ASME standards, the chamfer length of the tap and 1-2 threads safety margin. Deep drilling is necessary whenever taps with maximum thread length acc. ASME B94.9 are to be used

1) La profondeur d'avant-trou t_1 tient compte des longueurs L_1 et L_3 selon norme ASME ainsi que de la longueur d'entrée du taraud et de 1 à 2 filets de sécurité. Le perçage profond est nécessaire pour les cas où les tarauds avec longueurs de peignes maximales selon ASME B94.9 sont utilisés.

1) La profondità del preforo t_1 tiene conto delle lunghezze L_1 e L_3 secondo norma ASME ed anche la lunghezza d'imbocco del maschio da 1 a 2 filetti di sicurezza. La foratura profonda è necessaria se vengono utilizzati maschi con lunghezze filetto massime secondo ASME B94.9.

GEWINDE-KERNLOCHDURCHMESSER FÜR KEGELIGES ROHRGEWINDE NPT, KEGEL 1:16

u ... /) ... /) ... /) ...

C

Empfehlung für das Vorarbeiten von Grundlöchern
Recommended preparation of blind holes
Recommandation pour préparation des trous borgnes
Raccomandazione per la preparazione di fori ciechi

Nenngröße. Nom. size Taille nom. Grand. nom.	Steigung Pitch Pas Passo	$\varnothing D_3$ (+0,05)	b	t min. ²⁾	$\varnothing D_4$ min.
1/16	27	6,39	7	10	7,6
1/8	27	8,74	7	10	10
1/4	18	11,36	10,2	14,5	13,1
3/8	18	14,80	10,6	15	16,5
1/2	14	18,32	13,8	19	20,5
3/4	14	23,67	14,2	20	25,8
1"	11 1/2	29,69	17	24	32,2
1 1/4	11 1/2	38,45	17,5	24,5	41
1 1/2	11 1/2	44,52	17,5	24,5	47,2
2"	11 1/2	56,56	18	25	59,2

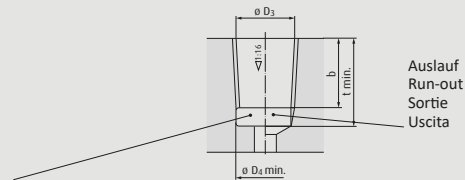

Ausführung mit Einstich bevorzugt anwenden
We recommend using a recessed design wherever possible
Nous recommandons la version avec entaille
Utilizzare preferibilmente versione con gola

2) Die Kernlochmaße sind auf Minimalängen nach ASME-Norm aufgebaut. Für Grundlöcher, welche die angegebenen Mindesttiefen t nicht zulassen, sind Sondergewindebohrer erforderlich. Eine bemafte Grundlochskizze ist zur Beurteilung notwendig.

2) The thread hole dimensions are based on minimal lengths acc. ASME standards. For blind holes which do not permit the indicated minimal depth t, special taps are necessary. A thread hole sketch with full dimensional specifications is necessary for making a decision.

2) Les dimensions d'avant-trou sont calculées à partir des longueurs minimales selon norme ASME. Pour les trous borgnes dont les profondeurs mini ne correspondent pas aux valeurs t indiquées, des tarauds spéciaux sont nécessaires. Dans ce cas nous vous prions de nous envoyer un croquis coté du trou borgne.

2) Le misure del preforo sono calcolate partendo dalle lunghezze minime secondo norma ASME. Per fori ciechi, le cui profondità minime t non sono previste nella tabella, sono necessari maschi speciali. In questo caso Vi preghiamo di inviarci uno schizzo quotato del foro cieco.

GEWINDE-KERNLOCHDURCHMESSER FÜR KEGELIGES ROHRGEWINDE NPTF, KEGEL 1:16

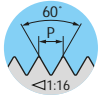

Voö

REIME NPTF-Gewindebohrer sind für die Lochformen A bis C geeignet. Für Gewinde mit höheren Anforderungen, z.B. NPTF-Gewinde für die Luftfahrt, empfehlen wir, das Kernloch nach Form B bzw. C auszuführen.

REIME NPTF taps are suited for the hole forms A to C. For threads with higher demands, e.g. NPTF threads for the aircraft industry, we recommend preparing the thread hole to form B, resp. C.

Les tarauds NPTF d'REIME sont appropriés pour les formes A, B et C. Pour taraudages destinés à de hautes exigences techniques, p.ex. le filetage NPTF pour l'industrie aéronautique, nous recommandons de percer l'avant-trou selon forme B ou C.

I maschi NPTF REIME sono appropriati per le forme di foro A fino a C. Per filettature per elevate esigenze, p.es. filettature NPTF per l'aviazione, raccomandiamo realizzare il preforo secondo forma B o C.

A

Zylindrisch vorbohren ohne Verwendung einer Reibahle
Drill cylindrically without using a reamer
Perçage cylindrique sans utilisation d'alésoir
Perforare cilindrico senza l'utilizzo di alesatore

Nenngröße.
Nom. size
Taille nom.
Grand. nom.

Steigung
Pitch
Pas
Passo

$\varnothing d_1$

P

$\varnothing D_1$

$t_1^{1)}$

t_4

Gg/1" (tpi)

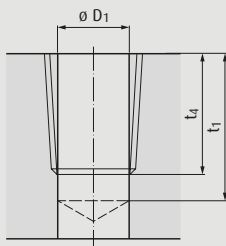

1/16	27	6,1	13	10,6
1/8	27	8,45	13	10,7
1/4	18	10,9	19,2	15,6
3/8	18	14,3	19,5	16
1/2	14	17,6	25,4	20,8
3/4	14	23	25,9	21,3
1"	11 1/2	28,75	31,1	25,6
1 1/4	11 1/2	37,5	31,7	26,1
1 1/2	11 1/2	43,75	31,7	26,1
2"	11 1/2	55,75	32,1	26,5

B

Zylindrisch vorbohren und kegelig aufreiben
Drill cylindrically and prepare tapered hole with reamer
Perçage cylindrique et alésage conique
Perforare cilindrico alesare conico

Nenngröße.
Nom. size
Taille nom.
Grand. nom.

Steigung
Pitch
Pas
Passo

$\varnothing d_1$

P

$\varnothing D_2$

$\varnothing D_3$

$t_1^{1)}$

t_4

Gg/1" (tpi)

(+0,05)

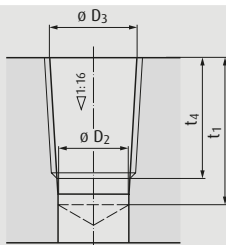

1/16	27	5,95	6,41	13	10,65
1/8	27	8,3	8,76	13	10,7
1/4	18	10,75	11,4	19,2	15,85
3/8	18	14,15	14,84	19,5	16
1/2	14	17,45	18,33	25,4	20,85
3/4	14	22,8	23,68	25,9	21,3
1"	11 1/2	28,65	29,72	31,1	25,6
1 1/4	11 1/2	37,35	38,48	31,7	26,1
1 1/2	11 1/2	43,45	44,55	31,7	26,1
2"	11 1/2	55,45	56,59	32,1	26,5

1) Die Vorbohrtiefe t_1 berücksichtigt die Längen L_1 und L_3 nach ASME-Norm, sowie die Anschnittlänge des Gewindebohrers und 1 bis 2 Gewindegänge Sicherheit. Tiefbohren ist erforderlich, wenn Gewindebohrer mit Maximal-Gewindelängen nach ASME B94.9 angewendet werden sollen.

1) The drill depth t_1 takes into account the lengths L_1 and L_3 acc. ASME standards, the chamfer length of the tap and 1-2 threads safety margin. Deep drilling is necessary whenever taps with maximum thread length acc. ASME B94.9 are to be used.

1) La profondeur d'avant-trou t_1 tient compte des longueurs L_1 et L_3 selon norme ASME ainsi que de la longueur d'entrée du taraud et de 1 à 2 filets de sécurité. Le perçage profond est nécessaire pour les cas où les tarauds avec longueurs de peignes maximales selon ASME B94.9 sont utilisés.

1) La profondità del preforo t_1 tiene conto delle lunghezze L_1 e L_3 secondo norma ASME ed anche la lunghezza d'imbocco del maschio da 1 a 2 filetti di sicurezza. La foratura profonda è necessaria se vengono utilizzati maschi con lunghezze filetto massime secondo ASME B94.9.

GEWINDE-KERNLOCHDURCHMESSER FÜR KEGELIGES ROHRGEWINDE NPTF, KEGEL 1:16

u $\sqrt{h_{u7}}$ /) $\sqrt{h_{u7}}$ /) $\sqrt{h_{u7}}$

C	Empfehlung für das Vorarbeiten von Grundlöchern Recommended preparation of blind holes Recommandation pour préparation des trous borgnes Raccomandazione per la preparazione di fori ciechi					
	Nenngröße. Nom. size Taille nom. Grand. nom.	Steigung Pitch Pas Passo	$\varnothing D_3$	b	t	$\varnothing D_4$
	$\varnothing d_1$	P	$\varnothing D_3$ (+0,05)	b	t min. ²⁾	$\varnothing D_4$ min.
<p>Ausführung mit Einstich bevorzugt anwenden We recommend using a recessed design wherever possible Nous recommandons la version avec entaille Utilizzare preferibilmente versione con gola</p>	1/16	27	6,41	8	11	7,4
	1/8	27	8,76	8	11	9,8
	1/4	18	11,4	11,6	15,5	12,9
	3/8	18	14,84	12	16	16,3
	1/2	14	18,33	15,6	20,5	20,3
	3/4	14	23,68	16	21,5	25,6
	1"	11 1/2	29,72	19,2	26	32
	1 1/4	11 1/2	38,48	19,7	26,5	40,8
	1 1/2	11 1/2	44,55	19,7	26,5	47
	2"	11 1/2	56,59	20,2	27	59

2) Die Kernlochmaße sind auf Minimal-längen nach ASME-Norm aufgebaut. Für Grundlöcher, welche die angegebenen Mindesttiefen t nicht zulassen, sind Sondergewindebohrer erforderlich. Eine bemafte Grundlochskizze ist zur Beurteilung notwendig.

2) The thread hole dimensions are based on minimal lengths acc. ASME standards. For blind holes which do not permit the indicated minimal depth t, special taps are necessary. A thread hole sketch with full dimensional specifications is necessary for making a decision.

2) Les dimensions d'avant-trou sont calculées à partir des longueurs minimales selon norme ASME. Pour les trous borgnes dont les profondeurs mini ne correspondent pas aux valeurs t indiquées, des tarauds spéciaux sont nécessaires. Dans ce cas nous vous prions de nous envoyer un croquis coté du trou borgne.

2) Le misure del preforo sono calcolate partendo dalle lunghezze minime secondo norma ASME. Per fori ciechi, le cui profondità minime t non sono previste nella tabella, sono necessari maschi speciali. In questo caso Vi preghiamo di inviarci uno schizzo quotato del foro cieco.

GEWINDE-KERNLOCHDURCHMESSER FÜR KEGELIGES ROHRGEWINDE RC (BSPT), KEGEL 1:16

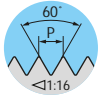

REIME



REIME Rc-Gewindebohrer sind für die Lochformen A bis C geeignet. Die Lochform A kann angewendet werden, wenn keine Dichtprobleme zu befürchten sind.

REIME Rc taps are suited for the hole forms A to C. Hole type A can be used when there is no reason to worry about sealing problems.

Les tarauds Rc d'REIME sont appropriés pour les formes A, B et C. Le type de trou A peut être utilisé quand des problèmes d'étanchéité peuvent être exclus.

I maschi Rc REIME sono appropriati per le forme di foro A fino a C. La forma di foro A può essere utilizzata se sono esclusi i problemi di tenuta.

A

Zylindrisch vorbohren ohne Verwendung einer Reibahle
Drill cylindrically without using a reamer
Perçage cylindrique sans utilisation d'álesoir
Perforare cilindrico senza l'utilizzo di alesatore

Nenngröße.
Nom. size
Taille nom.
Grand. nom.

Steigung
Pitch
Pas
Passo

$\varnothing d_1$

$\varnothing D_1$

$t_1^{(1)}$

t_1

P
Gg/1" (tpi)

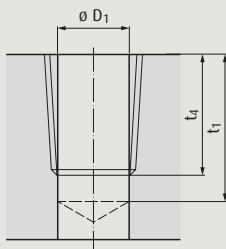

Rc 1/16	28	6,15	11,1	9,5
1/8	28	8,15	11,1	9,5
1/4	19	10,85	16,3	14
3/8	19	14,3	16,7	14,4
1/2	14	17,8	22,3	19,1
3/4	14	23,2	23,6	20,4
1"	11	29,2	28,3	24,3

B

Zylindrisch vorbohren und kegelig aufreiben
Drill cylindrically and prepare tapered hole with reamer
Perçage cylindrique et álésage conique
Perforare cilindrico alesare conico

Nenngröße.
Nom. size
Taille nom.
Grand. nom.

Steigung
Pitch
Pas
Passo

$\varnothing d_1$

$\varnothing D_2$

$\varnothing D_3$
(JS11)

$t_1^{(1)}$

t_1

P
Gg/1" (tpi)

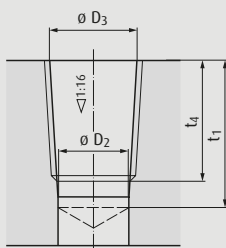

Rc 1/16	28	6,1	6,56	11,1	9,5
1/8	28	8,1	8,57	11,1	9,5
1/4	19	10,75	11,45	16,3	14
3/8	19	14,25	14,95	16,7	14,4
1/2	14	17,7	18,63	22,3	19,1
3/4	14	23,1	24,12	23,6	20,4
1"	11	29,1	30,29	28,3	24,3

GEWINDE-KERNLOCHDURCHMESSER FÜR KEGELIGES ROHRGEWINDE RC (BSPT), KEGEL 1:16

u k " "ohu /) k " "ohu /) k " "ohu

C

Empfehlung für das Vorarbeiten von Grundlöchern
Recommended preparation of blind holes
Recommandation pour préparation des trous borgnes
Raccomandazione per la preparazione di fori ciechi

Nenngröße. Nom. size Taille nom. Grand. nom.	Steigung Pitch Pas Passo	$\varnothing D_3$ (JS11)	b min.	t min. ²⁾	$\varnothing D_4$ min.
Rc 1/16	28	6,56	5,6	9,9	7,6 ^{+0,3}
1/8	28	8,57	5,6	9,9	9,6 ^{+0,3}
1/4	19	11,45	8,4	14,6	13 ^{+0,5}
3/8	19	14,95	8,8	15	16,5 ^{+0,5}
1/2	14	18,63	11,4	20	20,6 ^{+0,5}
3/4	14	24,12	12,7	21,3	26 ^{+0,5}
1"	11	30,29	14,5	25,4	32,8 ^{+0,5}

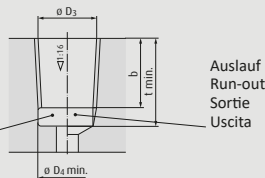

Auslauf
Run-out
Sortie
Uscita

Ausführung mit Einstich bevorzugt anwenden
We recommend using a recessed design wherever possible
Nous recommandons la version avec entaille
Utilizzare preferibilmente versione con gola

2) Für Grundlöcher, welche die angegebenen Mindesttiefen t nicht zulassen, sind Sondergewindebohrer erforderlich.
Eine bemaßte Grundlochskizze ist zur Beurteilung notwendig.

2) For blind holes which do not permit the indicated minimal depth t, special taps are necessary.
A thread hole sketch with full dimensional specifications is necessary for making a decision.

2) Pour les trous borgnes dont les profondeurs mini ne correspondent pas aux valeurs t indiquées, des tarauds spéciaux sont nécessaires.
Dans ce cas nous vous prions de nous envoyer un croquis coté du trou borgne.



2) Per fori ciechi, le cui profondità minime t non sono previste nella tabella, sono necessari maschi speciali.
In questo caso Vi preghiamo di inviarcì uno schizzo quotato del foro cieco.







UNSERE PRÄZISION IST IHR ERFOLG
OUR PRECISION IS YOUR SUCCESS



INTERNATIONALER
† - k M u \ 77 † - k 8 0 - @ # =
@







#







	R _m [N/mm ²]	A ₅ [%]	Rockwell [HRc]	EN	Brand name	Mat.-Nr.	 DIN	 AFNOR
MAGNETWEICHEISEN SOFT MAGNETIC STEEL FER PUR MAGNÉTIQUE FERRO DOLCE MAGNETICO								
P	P.1.1	<400				1.1011	RFe160	
	P.1.1	<400				1.1013	RFe100	
	P.1.1	<400				1.1014	RFe80	
	P.1.1	<400				1.1015	RFe60	
	P.1.1	<400				1.1017	RFe20	
	P.1.1	<400				1.1018	RFe12	
P	P.1.1	310-500	20		o 8u	1.0032	St34-2	
	P.1.1	310-500	20		o 8u	1.0034	ko	
	P.1.1	290-510	18		S185	1.0035	St33	
	P.1.1	340-510	25		o K8 #k	1.0036	USt 37-2	-
	P.1.1	340-510	25		S235JR	1.0037	St 37-2	-
	P.1.1	410-560	21		S275JR	1.0044	St 44-2	E 28-2
	P.1.1	340-470	25		S235J0	1.0114	St 37-3	E 24-3; E 24-4
	P.1.1	340-470	25		o K 8	1.0116	St 37-3	E 24-3; E 24-4
	P.1.1	340-510	25		o K#	1.0120	St37-1	
	P.1.1	410-560	21		o K#	1.0140	St 44-1	E 28-3; E 28-4
	P.1.1	410-560	21		o K 8	1.0144	St 44-3	E 28-3; E 28-4
	P.1.1	470-610	19		E295	1.0050	St 50-2	A 50-2
	P.1.1	470-610	19		S355J0	1.0553	St 52-3 U	E 36-3; E 36-4
	P.1.1	490-630	21		o K 8 #k	1.0570	St 52-3	E 36-3; E 36-4
	P.1.1	570-710	15		E335	1.0060	St 60-2	A 60-2
P.1.1	340-470	25		-	1.0038	RSt37-2	E24-2 Ne	
P.1.1	670-830	11		E360	1.0070	St 70-2	A 70-2	
P	P.1.1	310-450	26		S255	1.0461	StE 255	K 01800
	P.1.1	310-470	25		S275	1.0486	StE 285	
	P.1.1	360-510	23		S315	1.0505	StE 315	
	P.1.1	490-630	20		S380	1.8900	StE 380	
	P.1.1	500-680	19		S420	1.8902	StE 420	
	P.1.1	530-720	19		S460	1.8905	StE 460	
	P.1.1	560-760	17		S500	1.8907	StE 500	
	P.1.2	650-930	15		S690	1.8928		
P.1.2	980-1150	10		S960	1.8933			
P	P.1.1	360-480	26		P235S	1.0112	ch=	
	P.1.1	410-530	22		P265S	1.0310	ch=	
	P.1.1	390-510	24		P275SL	1.1100	ch=	
	P.1.1	360-480	24		h 8=	1.0345	=@	
	P.1.1	410-530	22		h 8=	1.0425	=@	
	P.1.1	440-580	21		h V=	1.0435	=@	
	P.1.1	460-580	21		h 8=	1.0481	17 Mr	
	P.1.1	390-510	24		h V=	1.0487	StE 285	
	P.1.1	390-510	24		P275NL1	1.0488		
	P.1.1	390-510	24		P275NL2	1.1104	EstE 285	
	P.1.1	510-650	20		h 8=	1.0473	19 Mr	
	P.1.1	490-630	22		P355N	1.0562	StE 355	A 510 AP
P.1.1	490-630	22		h V=	1.0565	StE 355	A 510 AP	
P.1.1	490-630	22		P355NL1	1.0566	TtE 355	A 510 FP	
P.1.1	490-630	22		P355NL2	1.1106	EtE 355		
P	P.1.1	360-530	9		-	1.0711	9 S 20	-
	P.1.1	380-570	8		-	1.0715	9 SMr28	S 250
	P.1.1	380-570	8		-	1.0718	9 SMPb 28	S 250 Pb
	P.1.1	360-530	9		-	1.0721	10 S 20	10 F 1
	P.1.1	360-530	9		-	1.0722	10 Spb 20	10 Pbf 2
	P.1.1	380-570	8		-	1.0723	15 S 20	-
	P.1.1	390-590	7		-	1.0736	9 SMr36	S 300
	P.1.1	390-580	7		-	1.0737	9 SMPb 36	S 300 Pb
	P.1.1	580-730	8		-	1.0726	35 S 20	35 MF 4
	P.1.1	660-800	7		-	1.0727	45 S 20	45 MF 4
P.1.1	740-880	7		-	1.0728	60 S 20	60 MF 4	
P	P.1.1	390-510	20		o U#	1.0972		
	P.1.1	420-540	19			1.0974	QStE 340 TM	
	P.1.1	420-580	19		o V#	1.0975	QStE 340 N	
	P.1.1	430-550	19		o U#	1.0976		
	P.1.1	450-590	18			1.0978	QStE 380 TM	
	P.1.1	480-640	16		o V#	1.0979	QStE 380 N	
	P.1.1	480-620	16		o U#	1.0980	QStE 420 TM	
P.1.1	520-670	14		o U#	1.0982	QStE 460 TM		
P.1.1	560-700	12		o V#	1.0983	QStE 460 N		







	 BS	EN	 UNI	 UNE	 JIS	 SIS	 AISI SAE ASTM
dZh•/KE EKE > ' d/							
							1010
							1010
					ouMJ ' #	-	-
					ouMJ ' #	-	-
4360-43 B	-		Fe 430 B FN	-	SM 41 B	1412	A 570.40
#	-		Fe 360 D FF	-	-	1312; 1313	A 573.58
#	-		Fe 360 D FF	-	-	1312; 1313	A 573.58
#	-		Fe 430 D FF	-	oU ' #	1412; 1414	A 573.70
#	-		Fe 430 D FF	-	oU ' #	1412; 1414	A 573.70
4360-50 B	-		Fe 490	-	SS 50	2172	A 570.50
4360-50 B	-		7 ' " #)	-	SM 50 X	2132	-
4360-50 B	-		7 ' " #)	-	SM 50 X	2132	-
4360-SSE; SS	-		Fe 590; Fe 600	-	SM 58	-	-
#	1A		-	-	ouMJ ' ° #	1311	A570.36
			Fe690; Fe70				A572.55
/ / K^dZh•/KE 'Z E &/E							
			K 02202				
			FeE285				° ° ° ° #
							A 633, A694
							# ° ° ° °
Z Z /W/ Ed/ WZ ^^/KE							
							° ° ° ° # °
							° ° ° ° 8 °
224-400 B	-		Fe E 285 KW				° ° ° ° 8 °
224-400 A	-		Fe E 285 KT				° ° ° ° 8 °
224-400 A	-						° ° ° ° 8 °
225-490 A	-		7 ' ° ° ° ° °				° ° ° ° 8 °
225-490 B	-		Fe E 355 KW				° ° ° ° 8 °
225-490 A	-		Fe E 355 KT				° ° ° ° 8 °
225-490 A	-						A707
220 M 07	-		#7 ' ° °		SUM 21	-	1212
230 M 07	-		#7 ' °U °	11SM08	SUM 22	1912	1213
-	-		#7 ' °U h °	11SM1b28	SUM 22 L	1914	12 L 13
210 M 15	-		#7 ' ° °	10S20	-	-	1108
-	-		#7 ' °h °	10SPb20	-	-	11 L 08
210 A 15	-		-	F.210.F	SUM 32	1922	-
240 M 07	1B		#7 ' °U °	12SM06	-	-	1215
-	-		#7 ' °U h °	12SMNPb36	-	1926	12 L 14
212 M 36	8M		-	7 ° 8	-	1957	1140
212 M 44	-		-	-	-	1973	1146
	-		-	-	-	-	-
Z K							
							045 X
							=oO o 78 °
							=oO o 78 °



	R _m [N/mm ²]	A ₅ [%]	Rockwell [HRC]	EN	Brand name	Mat.-Nr.	 DIN	 AFNOR
P	P1.1	550-700	12		o U#	1.0984	QStE 500 TM	
	P1.1	580-730	12		o V#	1.0985	QStE 500 N	
	P1.1	600-760	12		o U#	1.0986	QStE 550 TM	
	P1.1	600-750	12		o V#	1.0987	QStE 550 N	
	P1.1	650-820	11		o U#	1.8969		
	P1.1	700-880	10		o U#	1.8976		
	P1.2	750-950	10		o U#	1.8974	QStE 690 TM	
P	P1.1	440-590	24		-	1.5415	U	15 D 3
	P1.1	450-590	21		-	1.5423	U	-
	P1.1	490-640	20		-	1.5622	V	16 N 6
	P1.1	530-710	20		-	1.5680	V	Z8 N 5
	P1.1	450-660	20		-	1.7335	# U	#)
	P1.1	540-690	20		-	1.7337	# U	#)
	P1.1	480-630	18		-	1.7380	# U	#)
	P1.1	700-850	16		-	1.7709	# U	-
P1.1	490-640	20		-	1.7715	U	U	
P	P1.1	340-520	15		#	1.0301	#	7 #
	P1.1	360-520	13		#	1.0401	#	7 #
	P1.1	480-690	13		#	1.0402	#	##
	P1.1	590-780	13		# -	1.1141	#	#
	P1.1	620-880	20		# -	1.1151	#	#
	P2.1	750-1530	8		-	1.2764	CE V # U	-
	P1.1 P1.2	690-930	15		-	1.7012	#	-
	P1.1	650-880	16		-	1.7015	#	#
	P1.2	830-1080	11		-	1.5732	V #	V #
	P1.2	880-1180	10		-	1.5752	V #	V #
	P1.2 P1.3	1080-1420	8		-	1.5860	V #	-
	P1.2	780-1270	8		-	1.5919	# V	V #
	P1.2 P1.3	1080-1320	8		-	1.5920	V #	V #
	P1.2	690-1270	11		-	1.6523	V # U	V #)
	P1.2 P1.3	980-1420	8		-	1.6587	# V U	V #)
	P1.1 P1.2	650-1000	10		-	1.7131	U #	U #
	P1.1 P1.2	650-1000	10		-	1.7139	U # o	-
	P1.2 P1.3	780-1350	8		-	1.7147	U #	U #
	P1.2 P1.3	780-1350	8		-	1.7149	U # o	-
	P1.1 P1.2	640-1180	11		-	1.7262	# U	#)
P1.2 P1.3	780-1370	8		-	1.7264	# U	#)	
P1.2 P1.3	780-1380	8		-	1.7271	# U	-	
P1.2	780-1220	10		-	1.7311	# U	-	
P1.2	780-1180	10		-	1.7321	U #	-	
P1.2	780-1180	10		-	1.7323	U # o	-	
P1.2 P1.3	780-1370	8		-	1.7325	U #	-	
P1.2 P1.3	780-1370	8		-	1.7326	U # o	-	
P	P1.1	520-780	20		#	1.0406	#	7 #
	P1.1	520-780	19		#	1.0528	#	-
	P1.1	550-780	18		#	1.0501	#	7 #
	P1.1	550-820	16		#	1.0511	#	7 #
	P1.1	630-850	16		#	1.0503	#	7 #
	P1.1	520-780	19		# -	1.1158	#	#
	P1.1	520-780	18		# -	1.1178	#	-
	P1.1	550-780	17		# -	1.1181	#	# = #
	P1.1	550-820	16		# -	1.1186	#	# =
	P1.1	630-850	14		# -	1.1191	#	#
	P1.1	590-900	13		#	1.0540	#	-
	P1.1 P1.2	620-950	12		#	1.0535	#	-
	P1.1 P1.2	650-1000	11		#	1.0601	#	##
	P1.1	590-900	13		# -	1.1206	#	# =
P1.1 P1.2	620-950	12		#	1.1203	#	#	
P1.1 P1.2	650-1000	11		# -	1.1221	#	#	
P	P1.1	490-640	22		-	1.1133	20 M15	20 M 5
	P1.1	520-960	11		-	1.7735	# U	#)
	P1.1 P1.2	650-1020	13		-	1.3505	#	#
	P1.2	850-1130	11		-	1.5120	U o	-
	P1.2	830-1230	12		-	1.5121	U o	-
	P1.2	830-1230	12		-	1.5122	U o	-
	P1.1 P1.2	650-1000	13		-	1.5131	U o	-
P1.1 P1.2	690-1030	13		-	1.5141	U o	-	







	 BS	EN	 UNI	 UNE	 JIS	 SIS	 AISI SAE ASTM
Z K							=o 78
							=o 78
h • / KE							
1501-240	-		U	U	-	2912	8
1503-245-420	-		U	U	-	-	4520
-	-		V	V	-	-	A 350-LF 5
-	-		-	-	-	-	2515
8	-		# U	# U	-	2216	A 182-F11; F12
8	-		# U	-	-	2216	8 #
8	-		# U	-	-	2218	A 182-F22
-	-		-	-	-	-	-
1503-660-440	-		-	U # †	-	-	-
045 M 10	-		#	-	o #	-	1010
080 M 15	-		# #	F.111	-	1350	1015
050 A 20	#		# #	F.112	-	1450	1020
080 M 15	#		# #	F.111	o # o #M	1370	1015
050 A 20	-		#	-	o # o #M	-	1023
-	-		-	-	-	-	-
-	-		-	-	-	-	-
523 M 15	-		-	-	o#k =	-	5015
-	-		V #	V #	oV# =	-	3415
655 M 13	36A		-	-	oV# =	-	3310; 9314
-	-		-	-	-	-	-
S 107	-		# V	-	-	-	-
-	-		-	-	-	-	-
805 M 20	362		V # U	V # U	oV#U =	2506	8620
820 A 16	-		V # U	V # U	-	-	-
527 M 17	-		U #	U #	o#k	2511	5115
-	-		-	-	-	-	-
-	-		U #	-	oU # =	-	5120
-	-		-	-	-	-	-
-	-		# U	F.155	o#U =	-	-
-	-		-	-	o#U	-	-
-	-		-	-	-	-	-
-	-		-	-	-	-	-
-	-		-	-	-	-	-
-	-		-	-	-	-	-
-	-		-	-	-	-	-
> / ^ n / / KE / & / EKE > ' d /							
070 M 26	-		#	-	-	-	1025
-	-		-	-	-	-	-
060 A 35	-		#	F.113	-	1550	1035
-	-		#	-	-	-	1040
080 M 46	-		#	F.114	-	1650	1045
070 M 26	-		#	-	o #	-	1025
-	-		-	-	-	-	-
080 M 36	-		#	-	o #	1572	1035
080 M 40	-		#	-	o #	-	1040
080 M 46	-		#	# M	o #	1672	1045
-	-		-	-	-	-	-
070 M 55	-		#	-	-	1655	1055
080 A 62	43D		#	-	-	-	1060
080 M 50	-		-	-	-	-	1050
070 M 55	-		#	# M	o #	-	1055
080 A 62	43D		#	-	o #	1665; 1678	1060
/ KE / & / > ' d /							
120 M 19	-		8 U	-	-	-	1022; 1518
-	-		-	-	-	-	-
534 A 99	31		#	-	SUJ 2	2258	52100
-	-		-	-	-	-	-
-	-		-	-	-	-	-
-	-		-	-	-	-	-
-	-		-	-	-	-	-



		R _m [N/mm ²]	A ₅ [%]	Rockwell [HRC]	EN	Brand name	Mat.-Nr.	 DIN	 AFNOR
P	P1.2	780-1180	11		-	-	1.5710	V#	V#
	P1.1 P1.2 P1.3	630-1350	12		-	-	1.6546	V# U	V#)
	P1.1 P1.2 P1.3	720-1400	11		-	-	1.6565	V# U	-
	P1.1 P1.2	680-1100	13		-	-	1.7003	#	#
	P1.1 P1.2	720-1100	13		-	-	1.7006	#	#
	P1.1 P1.2	560-1000	15		-	-	1.7020	#	-
	P1.1 P1.2	560-1000	14		-	-	1.7030	#	-
	P1.1 P1.2	620-1100	14		-	-	1.7033	#	#
	P1.1 P1.2	600-1100	15		-	-	1.7218	# U	#) o
	P1.2 P1.3	700-1200	13		-	-	1.7220	# U	#)
	P1.2 P1.3	740-1270	12		-	-	1.7223	# U	#) uo
	P1.2 P1.3	750-1300	12		-	-	1.7225	# U	#) uo
	P1.2 P1.3	800-1300	12		-	-	1.7228	# U	-
	P1.1 P1.2	690-1080	13		-	-	1.1157	40 M14	35 M 5
	P1.1 P1.2	690-930	14		-	-	1.1165	30 M15	35 M 5
	P1.2	740-1080	10		-	-	1.1167	36 M15	40 M 5
	P1.1 P1.2	700-950	13		-	-	1.1170	28 M15	20 M 5
	P1.2	780-1080	13		-	-	1.3561	#	-
	P1.2 P1.3	780-1270	12		-	-	1.3563	# U	-
	P1.2 P1.3	880-1270	11		-	-	1.3565	# U	-
	P1.2 P1.3	880-1270	11		-	-	1.5223	U †	-
	P1.2 P1.3	880-1180	11		-	-	1.5736	V#	V#
	P1.2	830-1080	11		-	-	1.5755	V#	V#
	P1.2 P1.3	900-1300	11		-	-	1.6511	# V U	V#)
	P1.2	740-1030	13		-	-	1.6513	V# U	-
	P1.1 P1.2	630-1150	13		-	-	1.7034	#	#
	P1.2	760-1200	12		-	-	1.7035	#	#
	P1.2 P1.3	880-1270	11		-	-	1.7561	# †	-
	P1.2 P1.3	800-1300	11		-	-	1.8159	# †	#†
	P1.3	1240-1470	7		-	-	1.5864	V#	-
	P1.2 P1.3	900-1450	9		-	-	1.6580	# V U	#V)
	P1.2 P1.3	800-1400	11		-	-	1.6582	# V U	V#)
	P1.2	780-1180	12		-	-	1.7045	#	# uo
	P1.2 P1.3	840-1420	11		-	-	1.7361	# U	#)
	P1.2 P1.3	830-1450	10		-	-	1.7707	# U †	-
P1.2 P1.3	830-1600	10		-	-	1.8161	# †	-	
P1.3	1250-1400	10		-	=	-	-	-	
P	P1.1 P1.2	670-900	11		# y	-	1.1520	# †	-
	P1.1 P1.2	680-900	11		# y	-	1.1525	# †	Y 90; Y 80
	P1.1 P1.2	700-950	10		# y	-	1.1545	# †	Y 105
	P1.1 P1.2	670-900	11		-	-	1.1620	# †	-
	P1.1 P1.2	680-900	11		-	-	1.1625	# †	Y 80
	P1.1 P1.2	700-950	10		-	-	1.1645	# †	Y 105
	P1.1 P1.2	700-950	10		-	-	1.1654	# †	-
	P1.1 P1.2	710-1000	9		-	-	1.1663	# †	Y 120
	P1.1 P1.2	760-1000	9		-	-	1.1673	# †	Y 140
	P1.1 P1.2	630-850	16		# y	-	1.1730	# †	Y 42
	P1.1 P1.2	670-900	14		# y	-	1.1740	# †	Y 55
	P1.1 P1.2	650-900	14		-	-	1.1744	# †	-
	P1.1 P1.2	670-900	11		-	-	1.1750	# †	-
	P1.1 P1.2	640-870	13		-	-	1.1820	# †	-
	P1.1 P1.2	680-900	11		# y	-	1.1830	# †	Y 90
P	h' h' =			< 64	#	-	1.2067	#	#
	h' h' =			< 61	-	-	1.2101	oU #	-
	h' h' =			< 61	-	-	1.2103	o#	-
	h' h' =			< 62	-	-	1.2162	U #	V#
	h' h' =			< 62	-	-	1.2210	# †	#
	h' h' =			< 61	-	-	1.2330	# U	#)
	h' h' =			< 62	-	-	1.2332	# U	#)
	h' h' =			< 63	-	-	1.2419	† #	† #
	h' h' =			< 65	-	-	1.2510	U # †	U † #†
	h' h' =			< 66	-	-	1.2516	120 W	† #
	h' h' =			< 64	-	-	1.2542	† # †	-
	h' h' =			< 63	-	-	1.2550	† # †	† #
	h' h' =			< 57	-	-	1.2711	V# U †	V#) †
	h' h' =			< 55	-	-	1.2713	V# U †	V#) †
	h' h' =			< 59	-	-	1.2721	V#	-
h' h' =			< 62	-	-	1.2735	V#	V#	
h' h' =			< 53	-	-	1.2738	# U V U	-	







	R _m [N/mm ²]	A ₅ [%]	Rockwell [HRc]	EN	Brand name	Mat.-Nr.	 DIN	 AFNOR
t Z <• h'^d , > & mZ < > d Z / d n K > tKZ < dKK > ^d > ^ n / Z ^ Kh d / > ^ WKhZ dZ s / > & ZK /								
P	h' h' =		<63	-	-	1.2762	# U V †	-
	h' h' =		<60	-	-	1.2826	U o #	-
	h' h' =		<65	-	-	1.2833	†	†
	h' h' =		<65	-	-	1.2842	U # †	U †
	h' =		<62	-	-	1.2080	CE #	- #
	h' =		<62	-	-	1.2341	CE # U	-
	h' =		<64	-	-	1.2363	CE # U †	- #) †
	h' =		<66	-	-	1.2379	CE # † U	- #) †
	h' =		<66	-	-	1.2436	CE # †	-
	h' =		<66	-	-	1.2601	CE # U †	-
P1.2	860-1010	11	33-35	-	u	-	-	-
h' =	1320-1530	7	44-48	-	u	-	-	-
t Z <• h'^d , > & mZ t Z D Z / d n , K d tKZ < dKK > ^d > ^ n / Z ^ Kh d / > ^ WKhZ dZ s / > , h r								
P	h' h' =		<59	-	-	1.2744	V # U †	-
	h' =		<58	-	-	1.2767	CE V # U	- V #)
	h' =		<56	-	-	1.2083	CE #	- #
	h' =		<55	-	-	1.2343	CE # U †	- #) †
	h' =		<55	-	-	1.2344	CE # U †	- #) †
	h' =		<52	-	-	1.2365	CE # U †	- #) †
	h' =		<52	-	-	1.2567	CE † # †	- † # †
	h' =		<52	-	-	1.2581	CE † # †	- † # †
	h' =		<52	-	-	1.2885	CE # U †	-
	h' =		<52	-	-	1.2316	CE # U	-
h' h' =		<52	-	-	1.2311	# U U	-	
h' h' =		<52	-	-	1.2312	# U U o	-	
E/dZ/ Z^d , > n E/dZ/ /E' ^d > ^ n / Z ^ E/dZhZ ^ n / / E/dZhZ •/KE								
P	P1.2	800-1200	14	-	-	1.8504	# °	-
	P1.2	800-1200	12	-	-	1.8506	# ° o	-
	P1.2	800-1200	14	-	-	1.8507	# ° U	- #)
	P1.2	800-1200	12	-	-	1.8509	# ° U	- #)
	P1.2	800-1200	10	-	-	1.8515	# U	- #)
	P1.2	800-1200	9	-	-	1.8519	# U †	-
	P1.2	800-1200	10	-	-	1.8521	# U †	-
	P1.2	800-1200	8	-	-	1.8523	# U †	-
	P1.2	800-1200	12	-	-	1.8550	# ° V	-
^d , > h^ ^ n ^d > ^d / E' ^ n & KE d [/ Z ^ n ' , / ^ [/ / K								
P	P1.1	380-480	25	-	-	1.0420	8o	-
	P1.1	700-800	15	-	-	1.1118	8o U	-
	P1.1	480-620	20	-	-	1.1120	8o U	-
	P1.1	490-590	22	-	-	1.5419	8o U	-
	P1.1	590-740	18	-	-	1.5633	8o V	-
	P1.1	550-700	18	-	-	1.5681	8o V	-
	P1.1	700-800	12	-	-	1.6309	8o U U V	-
	P1.2	850-950	12	-	-	1.6579	8o # V U	-
	P1.2	800-900	13	-	-	1.6748	8o V # U	-
	P1.1	570-720	16	-	-	1.6750	8o V # U	-
	P1.1	570-720	21	-	-	1.6760	8o V U #	-
	P1.1	490-640	20	-	-	1.7357	8o # U	-
P1.1	520-670	21	-	-	1.7379	8o # U	-	
ZK^d s l ^ hZ ^d E / ' ^d , > & ZZ/d / ^ , n & ZZ/d / KZZK^/KE E / WZKK& ^d > ^ n / Z ^ /								
P	P2.1	400-600	17	-	-	1.4002	CE #	- #)
	P2.1	380-560	25	-	-	1.4512	CE # u	- # u)
	P2.1	400-600	19	-	-	1.4000	CE #	- #
	P2.1	450-600	18	-	-	1.4016	CE #	- #
	P2.1	500-700	12	-	-	1.4742	CE # ° o	- # ° o)
	P2.1	450-630	18	-	-	1.4113	CE # U	- #)
	P2.1	420-600	23	-	-	1.4510	CE # u	- # u)
	P2.1	400-600	20	-	-	1.4521	CE # U u	- # u)
	P2.1	450-650	15	-	-	1.4724	CE # ° o	- #
	P2.1	500-700	15	-	-	1.4749	CE # V	-
	P2.1	520-720	15	-	-	1.4762	CE #	- # ° o)
ZK^d s l ^ hZ ^d E / ' ^d , > D Z d E ^d / ^ , n KZZK^/KE E / WZKK& ^d > ^ s D Z d E ^d / n								
P	P2.1	650-850	12	-	-	1.4006	CE #	- #)
	P2.1	650-850	12	-	-	1.4005	CE # o	- #7)
	P2.1	650-950	15	-	-	1.4021	CE #	- #)
	P2.1	650-950	15	-	-	1.4028	CE #	- #)
	P2.1	650-950	12	-	-	1.4031	CE #	- #)
	P2.1	650-950	10	-	-	1.4034	CE #	- # U)
	P2.1	850-1100	12	-	-	1.4116	CE # U †	- #) †)
	P2.1	750-950	12	-	-	1.4122	CE # U	- #)
P2.1	780-1100	11	-	-	1.4313	CE # V	- # V)	



							
n	BS	EN	UNI	UNE	JIS	SIS	AISI SAE ASTM
	/ / > sKZ •/KE		& Z K				
-	-	-	-	-	-	-	-
BW	-	-	† My	-	SKS 43	-	W10
BO 2	-	-	U † # My	-	-	-	O 2
BD 3	-	-	CE # My	CE #	SKD 1	-	D 3
-	-	-	-	-	-	-	-
BA 2	-	-	CE # U † My	-	SKD 12	2260	A 2
BD 2	-	-	CE # † U My	-	SKD 11	-	D 2
-	-	-	CE # † My	CE # †	SKD 2	2312	-
-	-	-	CE # U † My	CE U †	-	2310	-
-	-	-	-	-	-	-	-
n	/ / > sKZ •/KE		> K				
-	-	-	-	-	-	-	-
-	-	-	V # U	-	-	-	-
-	-	-	CE # My	F-5263	SUS 420 J 2	-	-
" = "	-	-	CE # U † My	F-5317	SKD 6	-	" = "
" = "	-	-	CE # U † My	F-5318	SKD 61	-	" = "
" = "	-	-	CE # U † My	F-5313	SKD 7	-	" = "
-	-	-	CE † # † My	-	SKD 4	-	-
" = "	-	-	CE † # † My	CE † # †	SKD 5	-	" = "
" = "	-	-	-	F-5314	-	-	-
-	-	-	CE # U My	F-5267	-	-	-
-	-	-	# U	-	-	-	-
-	-	-	# U U	F-5302	-	-	-
-	-	-	-	-	-	-	-
-	-	-	-	-	-	-	-
905 M 31	-	-	# U	-	-	-	#)
905 M 39	41B	-	# U	# U	o # U	2940	# "
722 M 24	-	-	# U	-	-	2240	-
-	-	-	-	-	-	-	-
897 M 39	#	-	# U †	-	-	-	-
-	-	-	-	-	-	-	-
AM 1	-	-	-	-	-	-	A 27
-	-	-	-	F.8310	-	-	-
245	-	-	-	-	o#h=	-	-
-	-	-	-	-	-	-	-
-	-	-	-	-	-	-	A 757
-	24	-	-	-	oV#U	2541	-
-	-	-	-	-	-	-	-
-	-	-	-	-	-	-	-
621	-	-	-	F-8383	o#h=	-	A 217
622	-	-	-	-	o#h=	-	-
E Ky	d Z ^/ ^dX	/ ^ &	ZZ/d/Yh ^ n	/ / /EK^^/	/ > / U Z ^/ ^d Ed/	/ / & ZZ/d/ /	
405 S 17	-	-	CE #	-	SUS 405	2302	405
409 S 19	-	-	CE # u	-	oy =	-	409
403 S 17	-	-	CE #	F.3110	SUS 403	2301	403
430 S 15	960	-	CE #	F.3113	SUS 430	2320	430
430 S 15	-	-	CE #	F-3153	oy o' oy =	-	430
434 S 17	-	-	CE # U	F.3116	SUS 434	2325	434
-	-	-	CE # u	-	SUS 430 LX	-	CE u
-	-	-	-	F-3123	SUS 444	2326	444
-	-	-	-	F-3152	-	-	-
-	-	-	-	-	-	-	446
-	-	-	CE #	F.3154	oy =	-	446
/ Z ^ / EK y I Z ^/ ^dX	/ ^ sD	Zd E ^/ d/Yh	n	/ / /EKy	Z ^/ ^d Ed/	' > /	/ / sD Zd E ^/ d/
410 S 21	56A	-	CE #	F.3401	SUS 410	2302	#
416 S 21	-	-	CE # o	-	SUS 416	2380	416
420 S 37	-	-	CE #	-	SUS 420 J 1	2303	420
420 S 45	-	-	CE #	-	SUS 420 J 2	2304	420
-	-	-	CE #	-	SUS 420 J 2	2304	420
420 S 45	56D	-	CE #	F.3405	SUS 420 J 2	2304	420
-	-	-	-	F-3422	-	-	-
-	-	-	-	-	-	-	-
#	-	-	CE # V	-	o#o	2385	# VU







	R _m [N/mm ²]	A ₅ [%]	Rockwell [HRc]	EN	Brand name	Mat.-Nr.	 DIN	 AFNOR
ZK[^]ds [^] hZ [^]d E / [^]d , > D Z d E[^]/d/[^] , n KZZK[^]/KE E / WZKK& [^]d > [^]s D Z d E[^]/d/ n								
P	P2.1	840-1100	14	-	-	1.4418	CE # V U	- #V)
	P2.1	650-850	14	-	-	1.4024	CE #	- # U
	P2.1	640-840	11	-	-	1.4104	CE # U o	- #7
	P2.1	750-950	14	-	-	1.4057	CE # V	- #V
	P2.1	650-950	12	-	-	1.4747	CE # V o	- #oV
P2.1	750-950	12	-	-	1.4125	CE # U	- #)	
ZK[^]ds [^] hZ [^]d E / [^]d , > h[^] , / h E[^] , Z d E n KZZK[^]/KE E / WZKK& [^]d > [^]WZ / W/c								
P	P2.1	860-1400	13	-	h= U	1.4534		-
	P2.1	950-1400	13	-	h=	1.4545	CE # V # V	-
	P2.1	800-1400	14	-	h=	1.4542	CE # V # V	- #Vy
	P2.1	800-1200	12	-	h=	1.4568	CE # V	- #V
ZK[^]ds [^] hZ [^]d E / [^]d , > h[^]d E/d/[^] , n KZZK[^]/KE E / WZKK& [^]d > [^]h[^]d E/d/ n /								
M	M1.1	750-950	40	-	-	1.4372	CE # U V V	- #UV
	M1.1	680-880	35	-	-	1.4373	CE # U V V	-
	M1.1	600-950	40	-	-	1.4310	CE # V CE # V	- #V
	M1.1	630-850	35	-	-	1.4318	CE # V V	- #V
	M1.1	500-700	35	-	-	1.4305	CE # V o	- #V7
	M1.1	600-951	36	-	-	1.4350	CE # V	- #V
	M1.1	520-720	45	-	-	1.4301	CE # V	- #V
	M1.1	460-680	45	-	-	1.4306	CE # V	- #V
	M1.1	550-750	40	-	-	1.4311	CE # V V	- #V
	M1.1	510-710	45	-	-	1.4948	CE # V	-
	M1.1	520-700	45	-	-	1.4307	CE # V	- #V
	M1.1	500-750	40	-	-	1.4315	CE # V V	-
	M1.1	500-650	45	-	-	1.4303	CE # V	- #V
	M1.1	500-700	33	-	-	1.4833	CE # V	- #V
	M1.1	500-700	33	-	-	1.4845	CE # V	- #V
	M1.1	550-750	30	-	-	1.4841	CE # V o	- #Vo
	M1.1	520-680	40	-	-	1.4401	CE # V U	- #V)
	M1.1	530-730	40	-	-	1.4436	CE # V U	- #V)
	M1.1	520-680	40	-	-	1.4404	CE # V U	- #V)
	M1.1	520-700	40	-	-	1.4435	CE # V U	- #V)
	M1.1	520-700	40	-	-	1.4432	CE # V U	- #V)
	M1.1	580-780	40	-	-	1.4406	CE # V U V	- #V)
	M1.1	580-780	35	-	-	1.4429	CE # V U V	- #V)
	M1.1	490-740	40	-	-	1.4573	CE # V U u	-
	M1.1	520-690	40	-	-	1.4571	CE # V U u	- #Vu
	M1.1	520-720	40	-	-	1.4580	CE # V U V	- #V) V
	M1.1	550-700	35	-	-	1.4438	CE # V U	- #V)
	M1.1	580-780	35	-	-	1.4439	CE # V U V	- #V)
	M1.1	490-740	40	-	-	1.4583	CE # V U V	-
	M1.1	500-720	40	-	-	1.4541	CE # V u	- #Vu
	M1.1	500-720	40	-	-	1.4878	CE # V u	- #Vu
	M1.1	500-720	40	-	-	1.4550	CE # V V	- #VV
M1.1	500-700	40	-	-	1.4563	CE V # U #	- V#) y	
M1.1	520-730	35	-	-	1.4539	CE V # U #	- V#) y	
M1.1	550-750	30	-	-	1.4864	CE V # o	- V#o	
M1.1	500-740	30	-	-	1.4546	CE # V V	- #VV	
M1.2	900-1100	14	-	-	1.4718	CE # o	- #o	
M1.1		30	-	-	1.4828	CE # V o	- #Vo	
M1.3	950-1200	8	-	-	1.4871	CE # U V V	- #U V)	
M1.1		30	-	-	1.4876	CE V # u	- V#	
ZK[^]ds [^] hZ [^]d E / [^]d , > hW > y n KZZK[^]/KE E / WZKK& [^]d > [^]hW > y n / Z[^] / EK y I								
M	M1.1 M1.2	650-880	25	-	-	1.4462	CE # V U V	- #V)
	M1.1	600-830	25	-	-	1.4362	CE # V V	- #V)
	M1.1 M1.2	730-930	25	-	-	1.4410	CE # V U V	- #V)
	M1.1 M1.2	700-900	25	-	7	1.4507	CE # V U # V	- #V) y
	M1.1	620-800	25	-	-	1.4460	CE # V U V	- #V)
	M1.1 M1.2	650-900	30	-	-	1.4062	CE # V V	-
	M1.1 M1.2	650-900	25	-	-	1.4669	CE # # V V	-
	M1.1 M1.2	680-900	25	-	-	1.4424	CE # V U o	-
	M1.1 M1.2	650-900	25	-	-	1.4162	CE # U V V	-
	M1.1 M1.2	650-900	25	-	-	1.4482	CE # U V U V	-
	M1.1 M1.2	650-900	25	-	-	1.4662	CE # V U U # V	-
	M1.1 M1.2	730-930	25	-	-	1.4501	CE # V U # ± V	-
	M1.2	750-1000	25	-	-	1.4477	CE # V U V	-
	M1.2	800-1000	25	-	-	1.4658	CE # V U V	-
	GUSSEISEN MIT LAMELLENGRAPHIT CAST IRON WITH LAMELLAR GRAPHITE FONTES GRAPHITE LAMELLAIRE GHISE CON GRAFITE LAMELLARE							
K	K1.1	100-200				0.6010	88	Ft 10 D
	K1.1	150-250				0.6015	88	Ft 15 D
	K1.1	200-300				0.6020	88	Ft 20 D



											
BS		UNI		UNE		JIS		SIS		AISI SAE ASTM	
EN		E ^h /d/Yh n		E ^h /d/Yh n		Z ^h /^d Ed/ ' > /		sD Zd E ^h /d/			
-	-	-	-	-	-	-	-	-	2387	-	-
420 S 29	56B	-	-	-	-	SUS 410J1	-	-	-	-	420
-	-	CE # o	-	F-3431	-	SUS 430 F	-	2383	-	-	430 F
431 S 29	57	CE # V	-	F-3427	-	SUS 431	-	2321	-	-	431
443 S 65	59	CE # oV	-	F.320.B	-	oy =	-	-	-	-	=V†
-	-	CE # U	-	-	-	oy o' #	-	-	-	-	#
d/KEs, Z E n		Z ^h /^d X		s hZ / W Z WZ		W/d d/KE n		/ / EKy		Z ^h /^d Ed/ ' > /	
-	-	-	-	-	-	-	-	-	-	-	5629
-	-	-	-	-	-	-	-	-	-	-	5659
-	-	-	-	-	-	o#o	-	-	-	-	630
301 S 81	-	-	-	-	-	SUS 631	-	2388	-	-	631
Z ^h /EKyIZ ^/dX		s h^d E/d/Yh n		/ / EKy		Z ^h /^d Ed/ ' > /		/ / s h^d E/d/ K			
-	-	-	-	-	-	-	-	-	-	-	201
284 S 16	-	-	-	-	-	-	-	-	-	-	202
301 S 21	-	CE # V	-	F-3517	-	SUS 301	-	2331	-	-	301
-	-	-	-	-	-	-	-	-	-	-	301LN
303 S 21	58M	CE # V	-	F.3508	-	SUS 303	-	2346	-	-	303
304 S 31	58E	CE # V	-	F.3551	-	SUS 302	-	-	-	-	304
304 S 15	58E	CE # V	-	F.3551	-	SUS 304	-	2332; 2333	-	-	=
304 S 12	-	CE # V	-	F.3503	-	o#o	-	2352; 2333	-	-	304 L
304 S 62	-	CE # V V	-	-	-	SUS 304 LN	-	2371	-	-	304 LN
304 S 50	-	-	-	-	-	-	-	-	-	-	=
-	-	-	-	-	-	-	-	-	-	-	304 L
-	-	-	-	-	-	-	-	-	-	-	304 N
305 S 19	-	CE # V	-	-	-	SUS 305	-	-	-	-	308; 305
309 S 24	-	CE # V	-	-	-	SUS 309S	-	-	-	-	309 S
310 S 24	-	CE # V	-	F.331	-	SUS 310S	-	2361	-	-	310 S
314 S 25	-	-	-	F.3310	-	oy =	-	-	-	-	314
316 S 16	58J	CE # V U	-	F.3543	-	SUS 316	-	2347	-	-	316
316 S 16	-	CE # V U	-	F.3538	-	SUS 316	-	2343	-	-	316
316 S 11	-	CE # V U	-	F.3533	-	SUS 316 L	-	2348	-	-	316 L
317 S 12	-	CE # V U	-	-	-	o#o' oy o' O	-	2353	-	-	316 L
316 S 13	-	CE # V U	-	F-3537	-	-	-	-	-	-	316 L
316 S 61	#	CE # V U V	-	F-3542	-	SUS 316 LN	-	-	-	-	316 LN
316 S 62	-	CE # V U V	-	F-3543	-	SUS 316 LN	-	2375	-	-	316 LN
320 S 33	-	CE # V U u	-	-	-	oy o' u	-	-	-	-	u
320 S 31	58J	CE # V U u	-	F.3535	-	oy o' u	-	2350	-	-	u
318 S 17	-	CE # V U V	-	F.3536	-	-	-	-	-	-	#
317 S 12	-	CE # V U	-	F-3539	-	SUS 317 L	-	2367	-	-	317 L
-	-	-	-	F-3544	-	-	-	-	-	-	317 LMN
-	-	CE # V U V	-	-	-	-	-	-	-	-	318
321 S 12	58B	CE # V u	-	F.3553; F.3523	-	SUS 321	-	2337	-	-	321
321 S 31	-	-	-	-	-	SUS 321	-	-	-	-	=
347 S 17	58F	CE # V V	-	F.3552; F.3524	-	SUS 347	-	2338	-	-	347
-	-	-	-	-	-	-	-	2584	-	-	B 668
904 S 13	-	-	-	-	-	-	-	2562	-	-	904 L
NA 17	-	-	-	F.3313	-	oy =	-	-	-	-	330
347 S 18	58F	CE # V V	-	F-3524	-	SUS 347	-	2338	-	-	348
401 S 45	52	CE # o	-	-	-	oy =	-	-	-	-	=V†
309 S 24	-	-	-	-	-	oy =	-	-	-	-	309
349 S 54	-	CE # U V V	-	-	-	oy = oy =	-	-	-	-	-†
V =	-	-	-	-	-	V#7	-	-	-	-	B 163
Z ^h /^d X		s hW> y n		/ / EKy		Z ^h /^d Ed/ ' > /		/ / s hW> y			
318 S 13	-	-	-	-	-	SUS 329J3L	-	2377	-	-	318 LN
-	-	-	-	-	-	-	-	2327	-	-	-
-	-	-	-	-	-	o#o	-	2328	-	-	-
-	-	-	-	-	-	-	-	-	-	-	-
-	-	-	-	-	-	-	-	2324	-	-	329
-	-	-	-	-	-	-	-	-	-	-	2202
-	-	-	-	-	-	-	-	-	-	-	-
-	-	-	-	-	-	-	-	-	-	-	-
-	-	-	-	-	-	-	-	-	-	-	-
-	-	-	-	-	-	-	-	-	-	-	318 LN
-	-	-	-	-	-	-	-	-	-	-	-
-	-	-	-	-	-	-	-	-	-	-	-
8	-	8	-	78	-	7#	-	01 10-00	-	-	A48-20 B
8	-	8	-	78	-	7#	-	01 15-00	-	-	A48-25 B
8	-	8	-	78	-	7#	-	01 200	-	-	A48-30 B







	R _m [N/mm ²]	A ₅ [%]	Rockwell [HRC]	EN	Brand name	Mat.-Nr.	 DIN	 AFNOR
GUSSEISEN MIT LAMELENGRAPHIT CAST IRON WITH LAMELLAR GRAPHITE FONTES GRAPHITE LAMELLAIRE GHISE CON GRAFITE LAMELLARE								
K	K 1.1	250-350		-V 8KJ	-	0.6025	88	Ft 25 D
	K 1.1	300-400		-V 8KJ	-	0.6030	88	Ft 30 D
	K 1.1	350-450		-V 8KJ	-	0.6035	88	Ft 35 D
	K 1.1	400-500		-V 8KJ	-	0.6040	88	Ft 40 D
	K 1.1	170-210		EN-JL3011	-	0.6655	880V # #	OVy #
	K 1.1	170-210		-	-	0.6660	880V #	OV#
	K 1.1	190-220		-	-	0.6676	880V #	OV#
K 1.1	170-210		-	-	0.6680	880V o #	OV o #	
GUSSEISEN MIT KUGELGRAPHIT CAST IRON WITH NODULAR GRAPHITE FONTES GRAPHITE SPHÉROÏDAL GHISE CON GRAFITE NODULARE								
K	K 1.1	370-400	14	-V 8Kb	-	0.7040	888	78o
	K 1.1	420-500	7	-V 8Kb	-	0.7050	888	78o
	K 1.1	550-600	3	-V 8Kb	-	0.7060	888	78o
	K 1.1	660-700	2	-V 8Kb	-	0.7070	888	78o
	K 1.1	770-800	2	-V 8Kb	-	0.7080	888	78o
	K 1.1	370-480	7	-	-	0.7660	888 V #	oV #
	K 1.1	390-480	7	-	-	0.7661	888 V #	oV #
	K 1.1	370-450	20	-V 8Kc CE	-	0.7670	-V 8Kc CE	S-N 22
	K 1.1	440-480	25	-V 8Kc CE U	-	0.7673	-V 8Kc CE U	S-NM 23 4
	K 1.1	370-480	7	-V 8Kc CE #	-	0.7676	-V 8Kc CE #	oV #
	K 1.1	370-420	13	-	-	0.7677	888 V #	oV #
	K 1.1	390-500	1	-V 8Kc CE o #	-	0.7680	-V 8Kc CE o #	oV o #
	K 1.1	370-420	20	-V 8Kc CE	-	0.7683	-V 8Kc CE	S-N 35
K 1.1	370-450	7	-V 8Kc CE #	-	0.7685	-V 8Kc CE #	oV #	
GUSSEISEN MIT VERMICULARGRAPHIT CAST IRON WITH VERMICULAR GRAPHITE FONTES VERMICULAIRES GHISE CON GRAFITE VERMICOLARE								
K	K 1.1	300-375	2	-V 8Kf	-		88f	-
	K 1.1	350-425	2	-V 8Kf	-		88f	-
	K 1.1	400-475	1	-V 8Kf	-		88f	-
	K 1.1	450-525	1	-V 8Kf	-		88f	-
	K 1.1	500-575	1	-V 8Kf	-		88f	-
TEMPERGUSS MALLEABLE CAST IRON FONTES MALLÉABLES GHISE MALLEABILI								
K	K 1.1	300-350	10	-V 8KJ	-	0.8135	8u"	MN35-10
	K 1.1	420-450	6	-V 8KJ	-	0.8145	8u"	-
	K 1.1	480-550	4	-V 8KJ	-	0.8155	8u"	MP50-5
	K 1.1	620-650	2	-V 8KJ	-	0.8165	8u"	MP60-3
	K 1.1	660-700	2	-V 8KJ	-	0.8170	8u"	M870-2
	K 1.1	270-360	3	-V 8KJ ‡	-	0.8035	8u‡	MB35-7
	K 1.1	300-420	4	-V 8KJ ‡	-	0.8040	8u‡	MB40-10
	K 1.1	330-480	4	-V 8KJ ‡	-	0.8045	8u‡	-
K 1.1	490-570	3	-V 8KJ ‡	-	0.8055	8u‡	-	
'h ^ / ^ E h ^ & ZZ/d / ^ , ^ / % = , Z d ' h ^ n h ^ & ZZ/d / ^ d / Z K E ^ / % = , Z ^ d / E ' n & K E d								
K	K 2.1			< 55	-	0.9620	8K= CE V #	-
	K 2.1			< 55	-	0.9625	8K= CE V #	-
	K 2.1			< 64	-	0.9630	8K= CE # V o	-
	K 2.1			< 65	-	0.9635	8K= CE # U	-
	K 2.1	800	10	-V 8Kb	ADI 800	5.3400		-
	K 2.1	900	8	-V 8Kb	ADI 900	5.3402		-
	K 2.1	1050	6	-V 8Kb	ADI 1000	5.3403		-
	K 2.1	1200	3	-V 8Kb	ADI 1200	5.3404		-
K 2.1	1400	1	-V 8Kb	ADI 1400	5.3405		-	
ALUMINIUM UNLEGIERT ALUMINIUM UNALLOYED ALUMINIUM NON ALLIÉ ALLUMINIO NON LEGATO								
N	N 1.1	40-100	33	EN-AM090	-	3.0305		A9
	N 1.1	40-100	27	EN-AM080A	-	3.0128		A8
	N 1.1	40-100	27	EN-AM070A	-	3.0275		A7
	N 1.1	65-150	33	EN-AM050A	-	3.0225		A5
	N 1.1	65-150	33	EN-AM200	-	3.0205		A4
> h D / E / h D s < E d > ' / Z h E ' E E / , d h ^ , Z d Z n > h D / E / h D t Z K h ' , d >> K z ^ u E K d , Z E > n >								
N	N 1.1	100-125	1	EN-AL105	-	3.0505	U U	-
	N 1.1		2	EN-AL103	-	3.0515	U U	-
	N 1.1	210-330	4	EN-AL003	-	3.0517	U #	-
	N 1.1	115-250	1	EN-AL005	-	3.0525	U U	U 8
	N 1.1	100-205	4	EN-AL005	-	3.3315	U	8
	N 1.1	130-360	13	EN-AL019	-	3.3555	U	8
	N 1.1	150-300	3	EN-AL052	-	3.3523	U	8 #
	N 1.1	180-310	3	EN-AL0754	-	3.3535	U	8 U
N 1.1	120-350	15	EN-AL083	-	3.3547	oU U	8 U#	
> h D / E / h D s < E d > ' / Z h E ' E h ^ , Z d Z n > h D / E / h D t Z K h ' , d >> K z ^ s , Z E > n >> / ' ^ [> h D								
N	N 1.1	180-460	8	EN-AL011	-	3.1655	# " h	y h "
	N 1.1	180-310	8	EN-AL014	-	3.1255	# oU	y o8
	N 1.1	150-400	2	EN-AL017A	-	3.1325	# U	y 8
	N 1.1	180-460	3	EN-AL024	-	3.1355	# U	y 8

	 BS	EN	 UNI	 UNE	 JIS	 SIS	 AISI SAE ASTM
8	-	-	8	78	7#	01 250	A48-40 B
8	-	-	8	78	7#	1 300	A48-45 B
8	-	-	8	78	7#	1 350	A48-50 B
8	-	-	-	-	-	1 400	A48-60 B
OVy#	-	-	-	-	-	-	u
OV#	-	-	-	-	-	-	u
OV#	-	-	-	-	-	-	u
OV0#	-	-	-	-	-	-	u
oV8	-	-	80	888	7#)	0717-02	60-40-18
oV8	-	-	80	888	7#)	0727-02	65-45-12
oV8	-	-	80	-	7#)	0732-03	80-55-06
oV8	-	-	80	888	7#)	0737-01	100-70-03
oV8	-	-	80	-	-	-	120-90-02
oV#	-	-	-	F 43000	-	-	u)
oV#	-	-	-	F 43001	-	-	u) "
oV	-	-	-	F 43002	-	-	u) #
oVU	-	-	-	F 43003	-	-	u) U
oV#	-	-	-	-	-	-	u)
oV#	-	-	-	F 43004	-	-	u) "
oVo#	-	-	-	F 43005	-	-	u)
oV	-	-	-	F 43006	-	-	u)
oV#	-	-	-	-	-	-	u) "
-	-	-	-	-	-	-	-
-	-	-	-	-	-	-	-
-	-	-	-	-	-	-	-
-	-	-	-	-	-	-	-
-	-	-	-	-	-	-	-
"	-	-	-	8uo	-	0810	32510
h	-	-	-	8uo	-	0852	40010
h	-	-	-	8uo	-	0854	50005
h	-	-	-	8uo	-	0856	70003
h	-	-	-	8uo	-	0862; 0864	90001
‡	-	-	-	8u‡	7#U ‡	-	MB 350-4
‡	-	-	8U"	8u‡	7#U ‡	-	MB 400-5
-	-	-	8U"	8u‡	7#U ‡ h	-	MB 450-7
-	-	-	-	8u‡	-	-	-
h^& ZZ/d/Yh ^ /% = &KEd ^ dZ DW ^ n ',/^ h^& ZZ/d/ ^ /% = ',/^ /E KE ,/'>/							
8	-	-	-	-	-	0512-00	A532 I B
8	-	-	-	-	-	0513-00	A532 I A
8 #	-	-	-	-	-	-	A532 I D
8	-	-	-	-	-	-	@#
-	-	-	-	-	-	-	-
-	-	-	-	-	-	-	-
-	-	-	-	-	-	-	-
-	-	-	-	-	-	-	-
-	-	-	-	-	-	-	-
-	-	-	-	-	-	-	-
-	-	-	-	-	-	-	-
-	-	-	4509	-	-	-	-
-	-	-	4508	-	-	-	-
1B	-	-	4507	L-3051	-	-	-
#	-	-	3567	-	-	-	-
>/ '^ [>hD/E/hD KZZKz ^ u EKE hZ /^^ > n > ', D >> />/ / >>hD/E/K u EKE hZ />							
N31	-	-	-	-	-	-	3105
N3	-	-	3568	L-3810	144054	-	-
-	-	-	-	-	-	-	3568
-	-	-	-	-	-	-	-
N41	-	-	5764	L-3350	-	144106	5005
N6	-	-	3576	-	-	-	-
2L56	-	-	4574	-	-	-	5052
N5	-	-	3575	L-3390	-	-	-
N8	-	-	7790	-	-	-	5083
D/E/hD KZZKz ^ s hZ /^^ > n > ', D >> />/ / >>hD/E/K s hZ />							
7#	-	-	6362	-	-	-	-
=	-	-	-	-	-	-	3581
=	-	-	3579	L-3120	-	-	2017
2L97	-	-	3579	L-3140	-	-	2024

	R _m [N/mm ²]	A ₅ [%]	Rockwell [HRc]	EN	Brand name	Mat.-Nr.	 DIN	 AFNOR
>hD/E/hDs<E d> ' / ZhE' E h^, Zd Zn >hD/E/hD tZKh',d >>Kz^ s, Z E > n >> / ' ^ [>hD								
N	N 1.1	330-370	8	EN- AW 030	-	3.1645	° # h U	AU4Pb
	N 1.1	120-300	2	EN- AW 061	-	3.3211	° U o#	-
	N 1.1	130-360	2	EN- AW 082	-	3.2315	° U o	° o8U
	N 1.1	130-270	8	EN- AW 060	-	3.3206	° U o	-
	N 1.1	410-490	3	EN- AW 022	-	3.4345	° - U #	° - '8y
N 1.1	180-560	1	EN- AW 075	-	3.4365	° - U #	° - 8y	
>hD/E/hDs'h^^s> ' / ZhE' E ^/ D ñ9 n >hD/E/hD ^d >>Kz^ ^/ D ñ9 n &KEd ^ [>h ^/ D ñ9 n								
N	N 1.2	280-300	1	-V ° #	-	3.2134	8 ° o # U	-
	N 1.2	320-360	5	-V ° #	-	3.1371	8 ° # U u	° y 8u
	N 1.2	140-300	2	-	-	3.3241	8 ° U o	-
	N 1.2	170-200	1	-V ° #	-	3.3292	8) ° U	° 8 o
	N 1.2	140-210	4	-V ° #	-	3.3541	8) ° U	° 8 u
>hD/E/hDs'h^^s> ' / ZhE' E ^/ ñ sí9 n >hD/E/hD ^d >>Kz^ ^/ ñ sí9 n &KEd ^ [>h ^/ ñ sí								
N	N 1.2	210-250	3	-V ° #	-	3.2371	8 ° o U	° o 8
	N 1.2	230-360	2	-V ° #	-	3.2373	8 ° o U	° o 8
	N 1.2	240-350	3	-V ° #	-	3.2163	8 ° o #	A-S9U3
	N 1.2	150-340	1	-V ° #	-	3.2381	8 ° o U	° o 8
	N 1.2	140-160	1	-V ° #	-	3.2383	8 ° o U #	° o 8y
	N 1.2	150-170	5	-V ° #	-	3.2581	8 ° o	A-S13
	N 1.2	150-290	1	EN-AB-47000	-	3.2583	8 ° o #	A-S12U
>hD/E/hDs'h^^s> ' / ZhE' E ^/ E í9 n >hD/E/hD ^d >>Kz^ ^/ E í9 n &KEd ^ [>h ^/ E í9								
N	N 1.3	280-380	5	-V ° #	-	-	° o U # V	° o 'y8V'
	N 1.3	165-370	1	-V ° #	-	-	8 ° o # U	-
	N 1.3	180-220	1	-	-	-	8 ° o # VU	-
	N 1.3	200-240	1	-	-	-	8 ° o # VU	-
	N 1.3	230-300	3	-	-	-	8 ° o # VU	-
Z /E<hW& ZU E/ Z/'> ' / Zd ^ <hW& Zn WhZ KWW ZU >Kt >>Kz KWW Zn h/sZ WhZU h								
N	N 2.1	260-550	25	-V #† O	-	2.0240	# - 'Uo	# -
	N 2.1	270-490	25	-V #† O	-	2.0265	# - 'Uo	# -
	N 2.1	200-360	20	-V #† "	# -uh	2.0065	- #	-
	N 2.1	410-620	20	-V #† #	-	2.1248	# " h	# " h
	N 2.1	400-600	15	-V #† #	'U#\O''	2.1247	# "	# " h
	N 2.1	480-650	15	-V #† #	-	2.0850	# V "	-
	N 2.1	200-570	25	-V #† #	-	2.1580	# -	-
<hW& Zs•/E<s> ' / ZhE' E ^D ^^/E'‰ > E'^W E E n KWW Zs•/E >>Kz^ ^ Z ^^‰ ^>KE's ,/WW								
N	N 2.1	200-440	20	-V #† O	-	2.0321	# -	# -
	N 2.1	290-540	30	-V #† V	-	2.0335	# - h 'U	# - h
	N 2.1	340-480	25	-V #† O	-	2.0360	# - 'U	-
	N 2.1	250-340	30	-V #† V	-	-	# - h °	-
	N 2.1	360-400	25	-V #† V	-	2.0401	# - h	# - h
	N 2.1	290-480	30	-V #† V	-	2.0332	# - h 'U	-
<hW& Zs•/E<s> ' / ZhE' E ^D ^^/E'‰ <hZ^AW E E n KWW Zs•/E >>Kz^ ^ Z ^^‰ ^,KZds ,/W								
N	N 2.2	600-820	12	-V #† k	-#\k'oo	-	# - o h	-
	N 2.2	360-560	25	-V #† V	-	2.0380	# - h 'U	# - h
	N 2.2	450-620	18	-V #† k	-	2.0580	# - U h	-
	N 2.2	370-410	25	-V #† V	-	2.0402	# - h 'U	-
<hW& Zs >hs> ' / ZhE' E > E'^W E E n KWW Zs >hDX >>Kz^ ^>KE's ,/WW/E'‰ n >> / ' ^ h/								
N	N 2.1	480-590	30	-V #† 8	-	2.0932	# ° 7	# ° 7
	N 2.1	300-500	12	-V #† =	-	2.0872	# V 7 U	-
	N 2.1	480-550	40	-	-	-	-	-
<hW& Zs >hs> ' / ZhE' E <hZ^AW E E n KWW Zs >hDX >>Kz^ ^,KZds ,/WW/E'‰ n >> / ' ^ h/								
N	N 2.3	730-760	1	-	-	-	-	-
	N 2.3	0	40	-	-	-	-	-
	N 2.3	900-1000	4	-	U	-	-	-
	N 2.2	600-650	15	-V ## 8	-	2.0975	# ° 7 V #	# ° 7 V
	N 2.2	600-640	15	-V #† 8	-	2.0966	# ° V 7	# ° V 7 U
N 2.2	340-650	25	-V #† =	-	2.0875	# V o	-	
<hW& Zs•/EEs> ' / ZhE' E ^ ZKE•‰ > E'^W E E n KWW Zsd/E >>Kz^ ^ ZKE•‰ ^>KE's ,/WW								
N	N 2.1	290-630	25	-V #† M	-	2.1016	# o	-
	N 2.1	390-620	15	-V #† M	-	2.1030	# o h	-
	N 2.1	230-320	12	-V ## M	-	2.1093	# o - h	# o - h
	N 2.1	230-320	12	-V ## M	-	2.1090.01	# o - h 'k	# o h -
	N 2.1	280-340	18	-V ## M	-	2.1086.01	8 # o - 'k	-
N 2.3	770-820	18	-	-	-	-	-	
<hW& Zs•/EEs> ' / ZhE' E ^ ZKE•‰ <hZ^AW E E n KWW Zs >hD/E/hD >>Kz^ ^ ZKE•‰ ^,KZ								
N	N 2.2	180-220	12	-V ## M	-	2.1098	# o - h	-
	N 2.2	200-250	6	-V ## M	-	2.1097	# o - h 'k	# o h -
	N 2.2	250-280	10	-V ## M	-	2.1050	# o #	-
	N 2.2	280-300	8	-V ## M	-	2.1060	# o V #	-

	 BS	EN	 UNI	 UNE	 JIS	 SIS	 AISI SAE ASTM
D/E/hD	KZZKz ^ s hZ /^^	> n > ', D >>	/>/ / >>hD/E/K s hZ />				
-	-	-	-	-	-	-	-
=	-	-	3571	L-3451	-	144212	-
=	-	-	3569	L-3441	-	144103	-
L86	-	-	811-04	-	-	-	7050
2L95	-	-	3735	-	-	-	7175
> ', &h^ / >>hD/E/K	KE ^/ D ñ9						
-	-	-	-	-	-	-	-
-	-	-	-	-	-	-	-
-	-	-	5080	-	-	-	-
-	-	-	3059	-)#	-	-
î9 n > ', &h^ / >>hD/E/K	KE ^/ ñ sí9						
LM1.25	-	-	8° o U	-	*# #	-	-
-	-	-	3051	-	*# °	-	-
LM1.24	-	-	5075	-	-	-	-
LM9	-	-	3051	L-2560	-	4253	-
LM 9	-	-	-	-	-	4253	A 360.2
LM 6	-	-	3051	-	*#	4261	A 413.2
LM 20	-	-	3048	-	-	4260	A 413.1
n > ', &h^ / >>hD/E/K	KE ^/ E î9						
-	-	-	-	-	-	-	4032
-	-	-	-	-	-	-	-
-	-	-	-	-	-	-	-
-	-	-	-	-	-	-	-
/sZ & / > D Ed >>/	n Z D WhZKU Z D WK K > ' dK						
#-	-	-	-	-	#	-	#
#-	-	-	-	-	#	-	#
-	-	-	-	-	-	-	-
-	-	-	# "	-	-	-	-
-	-	-	# -	-	-	-	-
E'‰ n >>/ ' ^ h/sZ s•/E ^> /dKE^‰ ^ KWX >KE'^‰ n > ', Z D s•/E K ^KddKE ‰ ^dZh /K>K >hE'K‰							
#-	-	-	-	-	#	-	#
#-	-	-	h# -	-	#	-	#
)#"	-	-	-	-	-	-	#
#-	-	-	-	-	-	-	#
#-	-	-	-	-	-	-	-
-	-	-	-	-	-	-	-
V/E'‰ n >>/ ' ^ h/sZ s•/E ^> /dKE^‰ ^ KWX KhZd^‰ n > ', Z D s•/E K ^KddKE ‰ ^dZh /K>K							
-	-	-	-	-	-	-	-
-	-	-	h# - h`h\ u h	-	-	-	-
#-	-	-	-	-	-	-	-
#-	-	-	# - h o`h\ u h	-	-	-	-
sZ s >hX ^ KWX KhZd^‰ > ', Z D s >>hDX ^dZh /K>K >hE'K‰							
#-	-	-	h# ° 7	-	-	-	-
-	-	-	-	-	#Vh	-	#
-	-	-	-	-	-	-	-
h/sZ s >hX ^ KWX >KE'^‰ > ', Z D s >>hDX ^dZh /K>K KZdK‰							
-	-	-	-	-	-	-	-
-	-	-	-	-	-	-	-
-	-	-	-	-	-	-	-
AB2	-	-	8# ° 7 V	# ° 7 V #	° "#	-	#
#-	-	-	h# ° 7 V	-	-	-	#
-	-	-	-	-	-	-	#
E'‰ n >>/ ' ^ h/sZ s d /E ^ ZKE• ‰ ^ KWX >KE'^‰ n > ', Z D s^d 'EK ^ ZKE•K‰ ^dZh /K>K >hE'K‰							
-	-	-	-	-	#	-	#
-	-	-	-	-	#	-	#
# o h -	-	-	-	-	h" #	-	#
-	-	-	# o - h	-	-	-	#
-	-	-	-	-	-	-	-
-	-	-	-	-	-	-	-
ds ,/WX‰ n >>/ ' ^ h/sZ s >hX ^ ZKE• ‰ ^ KWX KhZd^‰ n > ', Z D s >>hD/E/K ^ ZKE•K‰ ^dZh /K>K							
ØB	-	-	-	-	-	-	#
ØB	-	-	# o - h "°-V'	-	='	-	#
# o h`h"	-	-	# o ° 8"	-	h" #	5443	#
# o V`#u	-	-	-	-	-	-	#

	R _m [N/mm ²]	A ₅ [%]	Rockwell [HRc]	EN	Brand name	Mat.-Nr.	 DIN	 AFNOR
•/E<s> '/ ZhE' E n •/E >>Kz^ n h/sZ s•/E n > ', •/E K								
N	N3.1	300	6	-	ZMAK	-	- ° -	Z4
	N3.1	330	4	-	ZMAK	-	- ° # -	Z4U1
	N3.1	400	6	-	ZMAK	-	- ° # -	Z4U3
D 'E ^/hDs> '/ ZhE' E n D 'E ^/hD tZKh',d >>Kz^ n >>/' ^ D 'E ^/hD KZZKz ^ n > ', D >								
N	N4.1	260-280	9	-V U 8 h	-	3.5612	U ° -	-
	N4.1	200-260	4	EN-MB-21120	-	3.5912	8 U ° -	-
	N4.1	230-250	10	-V U 8 h	-	3.5314	U ° -	8 ° -
	N4.1	200-230	8	-V U 8 h	-	-	U - -	8 ° -
	N4.1	220-250	8	-	-	3.5161	U - -	-
KUNSTSTOFFE SYNTHETICS PLASTIQUES MATERIE PLASTICHE								
N	N5.1	-	-	-	PMMA	-	-	-
	N5.1	-	-	-	POM	-	-	-
	N5.1	-	-	-	ht#	-	-	-
	N5.2	-	-	-	"	-	-	-
	N5.2	-	-	-	h	-	-	-
& ^ Zs Z^d Z<d <hE^d^dK&& n &/ Z s Z /E&KZ ^zEd, d/ ^ n W> ^d/Yh ^ , Z' ^ E &/ Z ^ r								
N	N5.2	155-365	-	-	-	87M	-	-
	N5.2	190-210	-	-	-	#7M	-	-
	N5.2	190-210	-	-	-	#7M	-	-
	N5.2	-	-	-	-	AFK	-	-
E/ < >sl<K >dsl / ^ Es> '/ ZhE' E n E/ < >sl K >dsl/ZKE s >>Kz^ n >>/' ^ E/ < >sl K >d Z &								
S	S1.1	490-560	30	-	lvar 36	1.3912	V	-
	S1.1	500-600	30	-	lvar 42	1.3917	V	-
	S1.1	-	35	-	U	2.4360	V# 7	V °
	S1.1	-	17	-	U M	2.4375	V# °	V ° ° u
	S1.2	1100-1300	15	-	V	2.4662	V# U u	-
	S1.2	850-1700	30	-	= #	2.4819	VU #	-
	S1.2	700-1000	40	-	= "	2.4685	8 V U	-
	S1.2	800-1700	40	-	= #	2.4610	VU # u	-
	S1.2	700-1000	40	-	= "	2.4617	8 V U	-
	S1.2	700-1500	26	-	V	2.4630	V# u	V# ° u
	S1.2	980-1150	8	-	° (E	2.4669	V# 7 u °	-
	S1.2	890-1600	30	-	@	2.4856	V# U V	V# ° 7) V
	S1.2	800-1000	12	-	V	2.4631	V# u °	-
	S1.2	1100-1600	12	-	@	2.4668	V# 7 V U	V# ° 7 V
	S1.2	1100-1300	21	-	Red 1	2.4973	V@ # U u	V# M u
	S1.2	800-1600	20	-	†	2.4654	V# # U u	V# M
	S1.2	1100-1300	17	-	V	2.4632	V# # u	V# ° ut
	S1.2	1000-1200	22	-	V	2.4634	V# # U ° u	V#M ° ut
S1.2	830-1130	25	-	° O ° O	2.4964	# # † V	-	
S1.2	900-1200	12	-	-	2.4979	# # U	-	
Z /Ed/d EU d/d E> '/ ZhE' E n WhZ d/d E/hDU d/d E/hD >>Kz^ n d/d E WhZU >>/' ^ d/d								
S	S2.1	290-410	30	-	-	3.7025	u ° ° u 8	AIR:9182T60
	S2.1	380-540	20	-	-	3.7035	u ° ° u 8	-
	S2.1	460-590	18	-	-	3.7055	u ° ° u 8	-
	S2.1	540-740	16	-	-	3.7065	u ° ° u 8	-
	S2.1	390-540	20	-	-	3.7235	u ° h ° u 8 h	-
	S2.2	800-1000	10	-	-	3.7165	u ° † ° u 8 °	u ° †
	S2.2	860-1100	18	-	u	3.7110	u ° 7	-
	S2.2	900-1100	13	-	-	-	u ° U †	-
	S2.2	800-1000	18	-	-	3.7115	u ° o	T-A5E
	S2.2	1100-1250	10	-	-	-	u ° o - U	-
	S2.2	1200-1300	11	-	-	-	u ° o - U # o	-
	S2.2	1050-1200	9	-	-	3.7185	u ° U o	-
GEHÄRTETE STÄHLE HARDENED STEELS ACIERS TRAITÉS ACCIAI TEMPRATI								
H	=	-	-	44-50	-	o	-	-
	=	-	-	49-51	=	u	-	-
	=	-	-	47-52	-	-	-	-
	=	-	-	53-55	=	-	-	-
	=	-	-	54-60	=	-	-	-
	=	-	-	57-63	=	-	-	-
=	-	-	62-64	-	7 u#V	-	-	

	 BS	EN	 UNI	 UNE	 JIS	 SIS	 AISI SAE ASTM
	-	-	A4	-	-	-	A8
	-	-	#	-	-	-	A8
	-	-	#	-	-	-	A8
> /> / / D 'E ^/K							
	-	-	-	-	-	-	-
	-	-	-	-	-	-	-
U°8-	-	-	-	-	-	-	-
	-	-	-	-	-	-	-
U°8-	-	-	-	-	-	-	-
	-	-	-	-	-	-	-
	-	-	-	-	-	-	-
	-	-	-	-	-	-	-
	-	-	-	-	-	-	-
n Z ^/E WK^^/ / ,							
	-	-	-	-	-	-	-
	-	-	-	-	-	-	-
	-	-	-	-	-	-	-
	-	-	-	-	-	-	-
Z d /Z ^ n > ', E/ , >I K >dK Z ^/^d Ed/ > K>KZ							K93600
							K94100
NA 13	-	-	-	-	-	-	-
NA 18	-	-	-	-	-	-	-
=k'	-	-	-	-	-	-	-
	-	-	-	-	-	-	SB575
	-	-	-	-	-	-	-
	-	-	-	-	-	-	-
=k'	-	-	-	-	-	-	-
	-	-	-	-	-	-	N07750
NA 21	-	-	-	-	-	-	-
=k'	-	-	-	-	V#7	-	-
	-	-	-	-	-	-	-
	-	-	-	-	-	-	5712
	-	-	-	-	-	-	5544
=k	-	-	-	-	-	-	-
=k	-	-	-	-	-	-	-
	-	-	-	-	-	-	5759
	-	-	-	-	-	-	F75
E n d/d E/K WhZKU > ', / d/d E/K							
	-	-	-	-	-	-	-
TA 1	-	-	-	-	-	-	-
TA 2	-	-	-	-	-	-	-
TA 3	-	-	-	-	-	-	-
	-	-	-	-	-	-	-
TA 28	-	-	-	-	-	-	R56400
	-	-	-	-	-	-	-
	-	-	-	-	-	-	R54810
TA 14, 17	-	-	-	-	-	-	B 265
	-	-	-	-	-	-	4981
	-	-	-	-	-	-	-
	-	-	-	-	-	-	-
	-	-	-	-	-	-	-
	-	-	-	-	-	-	-
	-	-	-	-	-	-	-

