

HJ

Standard Hard Jaws

Standard Hard Jaws



Dimensions

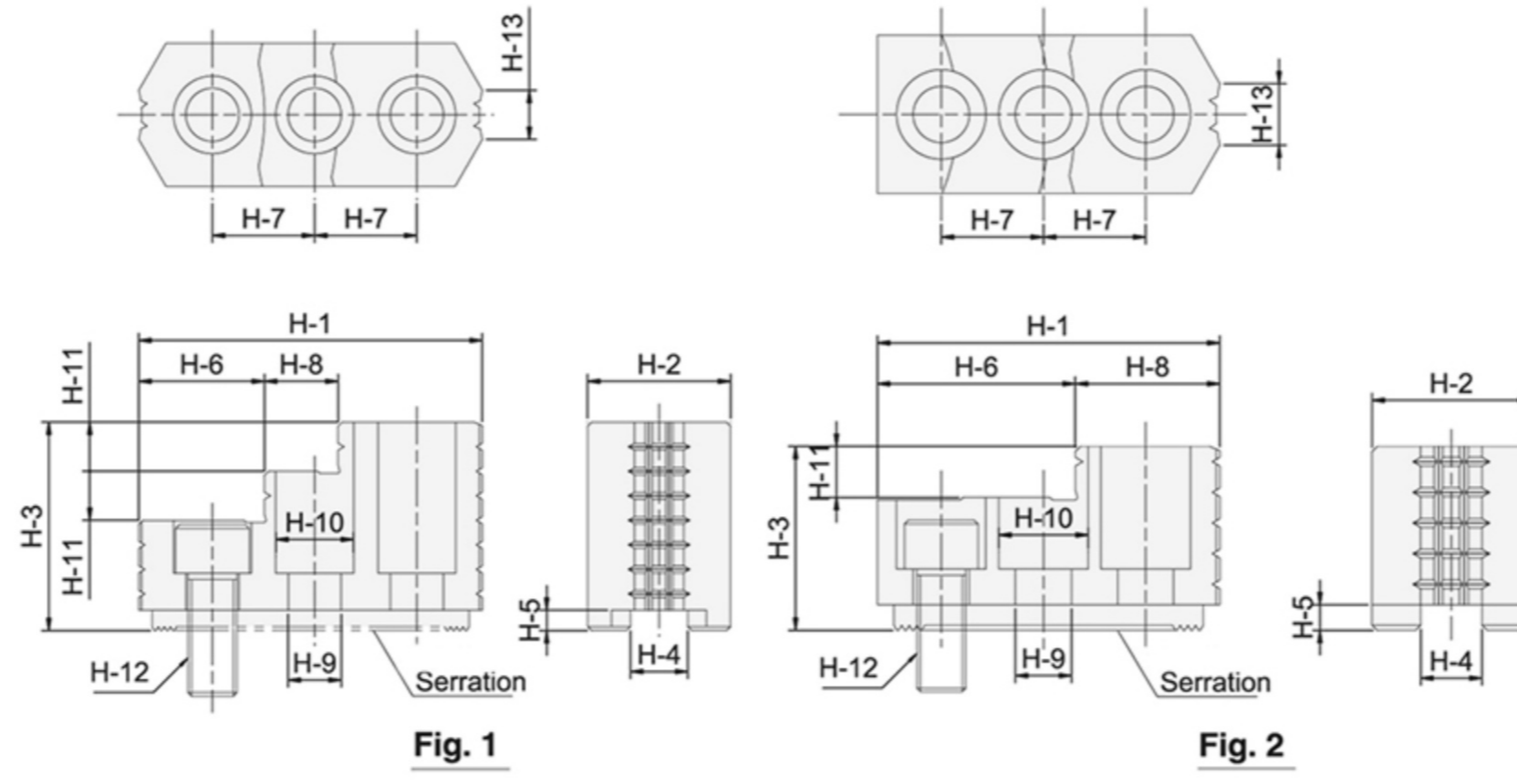

Subject to technical changes.

Model	H-1	H-2	H-3	H-4	H-5	H-6	H-7	H-8	H-9	H-10	H-11	H-12	H-13	Serration Pitch	Matching Chuck	3 Jaw Weight (kg)	Reference Drawing
HJ-05	53	23	28	10	4	30	14	23	8.5	13.5	10	M8	6	1.5×60°	3H-204, 3H-205	1.0	Fig.2
HJ-06	67	31	36	12	5	38.5	20	28.5	11	17	12	M10	10	1.5×60°	3H-206, 3P-06	1.7	Fig.2
HJ-08	87	35	51	14	5	32	25	18	13	19	12	M12	12	1.5×60°	3H-208, 3P-08	2.0	Fig.1
HJ-10	102	40	54	16	5	39	30	23	13	19	13	M12	16	1.5×60°	3P-10, 3H-210	3.0	Fig.1
* HJ-12H	103	50	52	21	5	62.5	30	40.5	17	25	17	M16	30	1.5×60°	3H-12, 3H-212, 3L-212, 3V-12, 3P-12, 3M-12	3.5	Fig.2
* HJ-12P	103	50	52	18	5	62.5	30	40.5	15	22	17	M14	30	1.5×60°	3H-12, 3H-212, 3L-212, 3V-12, 3P-12, 3M-12	3.6	Fig.2
* HJ-15H	149	62	86	22	8	63	43	34	21	32	20	M20	43	1.5×60°	3H-15, 3H-215, 3H-18, 3L-15, 3V-15, 3V-18, 3P-215, 3P-218	9.6	Fig.1
* HJ-15P	149	62	86	25.5	6	63	43	34	21	32	20	M20	43	1.5×60°	3H-15, 3H-215, 3H-18, 3L-15, 3V-15, 3V-18, 3P-215, 3P-218	9.5	Fig.1
HJ-21	159.5	80	90	25	9	104.5	50	55	21	32	40	M20	55	3.0×60°	3H-221, 3H-224, 3H-232, 3P-221, 3P-224, 3V-21, 3V-32, 3V-24	14.3	Fig.2

* For HJ-12H, HJ-12P, HJ-15H, HJ-15P, please confirm the dimension of H-4 before placing the order.