

Square shoulder milling insert FM902 series

KAPR=90°

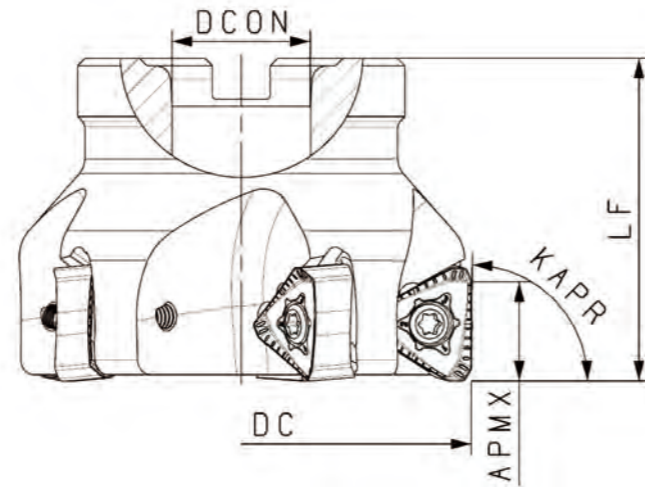

Type	stock	Number of flutes	Dimension						Interface	Adaptable Inserts	Screw	Wrench
			DC	DCX	DCON	LF	LH	APMX				
FM902-A22-50-4-TN13	●	4	50		22	40		13	A	TN*1306*	SA0411	T15P
FM902-A22-63-5-TN13	●	5	63		22	40		13	A			
FM902-A27-80-7-TN13	●	7	80		27	50		13	A			
FM902-B32-100-8-TN13	●	8	100		32	50		13	B			
FM902-B40-125-10-TN13	●	10	125		40	63		13	B			
FM902-C40-160-12-TN13	○	12	160		40	63		13	C			
FM902-C60-200-16-TN13	○	16	200		60	63		13	C			

● Stock available ○ Make-to-order

FM902 milling insert

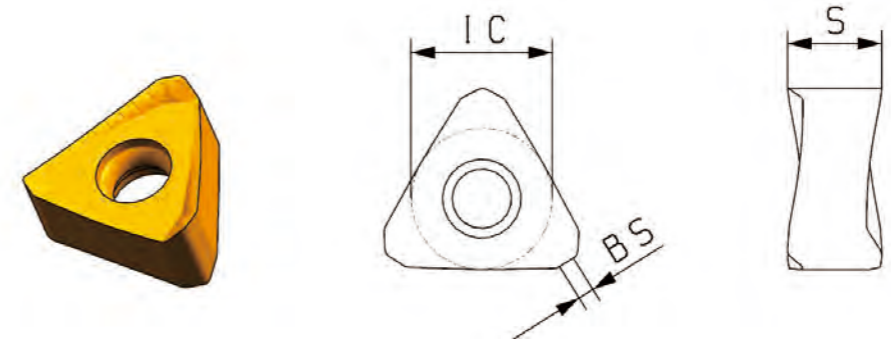

= stable cutting condition >> normal cutting condition # bad cutting condition

Material	Dimension								C V D	P V D							Uncoated percoat
	IC	L	W1	S	D1	RE	BS	OC3220		OP2202	OP1315	OP1325	OP1030	OP1630	OP1340	OK434	
P										=	>>	>>	>>	>>	#		
M											>>	>>			#		
K									>>	=	>>	>>	>>				
N																>>	
S																	
H																	
TNGX1306PNFR-1	11.46			7.6			1.3			○	○	●					

● Stock available ○ Make-to-order