

# 2025 Catalogue



**T**eknik Makina 1987 yılında otomotiv sektöründe imalat hayatına başlamıştır. Bir süre bu sektörde hizmet verdikten sonra 1994'te sektör değiştirerek, kesici takımlar imalatına adım atmıştır. Yaklaşık 5000'i aşkın ürün çeşidi ile geniş bir üretime sahiptir. Kurulduğundan bu güne kadar performans, kalite ve maliyet olarak en iyi ürünlerle hizmet vermeye devam etmektedir.

Kuruluşundan bu yana yüksek teknolojiye, yeniliklere, yeni projelere açık olup kendisini sürekli yenilemektedir.

ini arttırarak ISO9001:2015 belgesini almış; müşterilerinin var olan güvenini daha da pekiştirmiştir. Kısa ve uzun vadeli oluşturulmuş kalkınma plânlarıyla yıllık üretim adetlerini yükseltmeyi hedefleyen TEKNİK MAKİNA konusunda uzman çalışanları ile ilk günkü heyecan ve istekle çalışmalarını sürdürerek dünya ve Türkiye pazarındaki yerini daha da sağlamlaştırarak yükselen grafiğini aynı istikrarda yürütmeye ve ülke ekonomisine katkılarını sürdürmekte kararlıdır.

Ürünlerinin ve hizmetinin kalites-



Technical solution quality

Kalite için TEKNİK Çözüm

*Teknik Cutting tools has been established in 1987 in Turkey. Teknik Cutting Tools started to produce cutting tools in 1994. Over 5.000 kinds of tools are produced in the factory building located in the Fourth Industrial Area of Konya since 2015. Teknik Cutting Tools is a very experienced producer a large range of a Cutting Tools: Face Mills, End Mills, Boring Bars, External Turning Holders and more. There are 40 production lines which are capable to produce in several categories at the same time.*











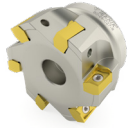

*We keep up to date with new products and when customers need special tools we do all we can to produce the tools to meet their expectations.*

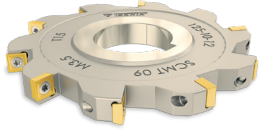
*Production and designing teams are all educated and certified according to the ISO 9001:2015 quality standard to serve you better.*

*The Company Headquarters is also located in Konya.*

*Konya and Istanbul branches are dedicated with marketing and sales. Teknik Cutting Tools does international trade as cutting tools exporter with many countries all around the World and offers the highest level of quality, service and reliability, in a very short lead-time with the best price, guaranteed.*



Page	Compatible Inset	
6-20	Face Mill - End Mill - Modular End Mill	
	Eckmesserkopf- Radius Cutter - Einschraubfräser	
22-35	End Mill	
	Radius Cutter	
38-41	Modular End Mill	
	Einschraubfräser	
44-49	Borings	
	Ausdrehwerkzeug	
52-53	Shoulder Milling - Disc Milling	
	Igelfräser - Scheibenfräser	
56-57	T-Slot Milling Cutter	
	T-Nutenfräser	
60-64	Threading Holder	
	Klemmhalter (Außengewinde)	
66-70	P System Turning Holder With Coolant	
	P System Drehhalter	
72-73	P System Turning Holder	
	P System Drehhalter	
76-80	D External Turning Holders	
	D System Klemmhalter	
82-88	S System External Turning Holders	
	S System system Klemmhalter	
90-92	P System Boring Bars	
	P System Bohrstange	
94-97	D System Boring Bars	
	D System Bohrstange	

Page	Product Type	
100-106	S System Boring Bars	
	S System Bohrstange	
108-110	Carbide Tools / Set	
	VHM Bohrstange / Set	
112-114	Boring Bars Set	
	Bohrstangen Set	
118-127	Indexable Drills	
	Vollbohrer	
130-137	Grooving Holders - Block For Blades	
	Stech-Klemmhalter - Grundhalter für Abstechtschwer	
140-143	Grooving Holders Bars - Mini Tool	
	Stech-Klemmhalter	
144-149	Spare Parts	
	Zubehör	

# Kalite için TEKNİK Çözüm

Technical solution for quality



Face Milling



[www.teknikcuttingtools.com](http://www.teknikcuttingtools.com)



**45° SNKX 1206**

Order Code	Product Code	Dimensions (mm)								
		D	D1	d	Z	H				
T319	D040 d16 Z03 SNKX 12	40	53	16	3	45	0,417	TC076	T15	
T320	D050 d22 Z04 SNKX 12	50	63	22	4	44	0,593	TC076	T15	
T322	D063 d22 Z06 SNKX 12	63	76	22	6	44	0,710	TC076	T15	SNKX 1206
T325	D080 d27 Z07 SNKX 12	80	93	27	7	52	1,334	TC076	T15	KRLY
T330	D100 d32 Z08 SNKX 12	100	113	32	8	52	1,926	TC076	T15	
T332	D125 d40 Z10 SNKX 12	125	138	40	10	63	3,780	TC076	T15	
T334	D160 d40 Z12 SNKX 12	160	173	40	12	63	5,380	TC076	T15	
T335	D200 d60 Z14 SNKX 12	200	213	60	14	63	6,690	TC076	T15	

Get information for cooling tool Compatible with / Kompatible für (KRLY-PLBT-BHLR)

**45° ONMX 0806**

Order Code	Product Code	Dimensions (mm)							
		D	d	Z	H				
T780	D063 d22 Z05 ONMX 08	63	22	5	40	1,063	TC083	T20	ONMX 0806 KRL
T782	D080 d27 Z06 ONMX 08	80	27	6	50	0,532	TC083	T20	ONMX 0806 ISCR
T784	D100 d32 Z07 ONMX 08	100	32	7	50	1,067	TC083	T20	ONMU 0806 YG1
T786	D125 d40 Z08 ONMX 08	125	40	8	63	3,574	TC083	T20	ONKX 0806 LMN

Get information for cooling tool Compatible with / Kompatible für (KRLY-ISCR-YG1-LMN)

**45° ONMX 0606**

Order Code	Product Code	Dimensions (mm)							
		D	d	Z	H				
T790	D063 d22 Z05 ONMX 06	63	22	5	45	0,657	TC083	T20	
T791	D080 d27 Z06 ONMX 06	80	27	6	50	1,110	TC083	T20	ONMX 0606
T792	D100 d32 Z07 ONMX 06	100	32	7	52	1,701	TC083	T20	KRLY

Get information for cooling tool Compatible with / Kompatible für (KRLY)

**90° WNGX 0806**

Order Code	Product Code	Dimensions (mm)							
		D	d	Z	H				
T775	D050 d22 Z05 WNGX 08	50	22	5	40	0,277	TC083	T20	
T776	D063 d22 Z06 WNGX 08	63	22	6	40	0,470	TC083	T20	WNGX 0806
T777	D080 d27 Z07 WNGX 08	80	27	7	50	1,105	TC083	T20	KRLY
T778	D100 d32 Z08 WNGX 08	100	32	8	52	1,580	TC083	T20	

Get information for cooling tool Compatible with / Kompatible für (KRLY)

**90° WNGX 0403**

Order Code	Product Code	Dimensions (mm)							
		D	d	Z	H				
T692	D040 d16 Z06 WNGX 04 IK	40	16	6	40	0,256	TC060	T8	
T693	D050 d22 Z08 WNGX 04 IK	50	22	8	40	0,347	TC060	T8	WNGX 0403
T694	D063 d22 Z10 WNGX 04 IK	63	22	10	40	0,617	TC060	T8	KRLY
T695	D080 d27 Z11 WNGX 04 IK	80	27	11	50	1,306	TC060	T8	

Compatible with / Kompatible für (KRLY)

**88° SNMX 1206**

Order Code	Product Code	Dimensions (mm)							
		D	d	Z	H				
T344	D063 d22 Z06 SNMX 12	63	22	6	40	0,574	TC076	T15	
T345	D080 d27 Z07 SNMX 12	80	27	7	50	1,213	TC076	T15	SNMX 1206
T346	D100 d32 Z08 SNMX 12	100	32	8	50	1,688	TC076	T15	KRLY

Get information for cooling tool Compatible with / Kompatible für (KRLY)

**90° LNMX 1006**

Order Code	Product Code	Dimensions (mm)							
		D	d	Z	H				
T386	D040 d16 Z05 LNMX 10	40	16	5	40	0,258	TC065	T8	
T387	D050 d22 Z06 LNMX 10	50	22	6	45	0,472	TC065	T8	LNMX 1006
T388	D063 d22 Z06 LNMX 10	63	22	6	45	0,495	TC065	T8	KRLY
T389	D080 d27 Z07 LNMX 10	80	27	7	50	0,731	TC065	T8	
T390	D100 d32 Z09 LNMX 10	100	32	9	50	1,700	TC065	T8	

Get information for cooling tool Compatible with / Kompatible für (KRLY)

**90° LNMX 1510**

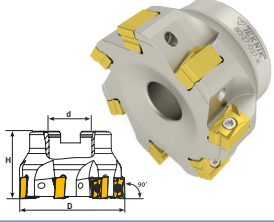

Order Code	Product Code	Dimensions (mm)					TC	T	KRLY
		D	d	Z	H	kg			
T372	D050 d22 Z04 LNMX 15	50	22	4	45	0,375	TC076	T15	
T374	D063 d22 Z06 LNMX 15	63	22	6	45	0,616	TC076	T15	
T376	D080 d27 Z07 LNMX 15	80	27	7	50	1,087	TC076	T15	LNMX 1510
T378	D100 d32 Z08 LNMX 15	100	32	8	52	1,644	TC076	T15	KRLY
T380	D125 d40 Z10 LNMX 15	125	40	10	63	3,650	TC076	T15	

Get information for cooling tool

Compatible with / Kompatible für (KRLY)

**90° XNKT 0805**

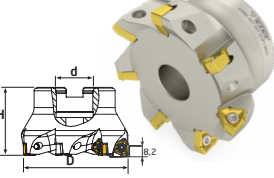

Order Code	Product Code	Dimensions (mm)					TC	T	KRLY
		D	d	Z	H	kg			
T900	D040 d16 Z04 XNKT 08	40	16	4	45	0,296	TC072	T15	
T902	D050 d22 Z05 XNKT 08	50	22	5	45	0,396	TC072	T15	XNKT 0805
T904	D063 d22 Z06 XNKT 08	63	22	6	45	0,575	TC072	T15	KRLY
T906	D080 d27 Z07 XNKT 08	80	27	7	50	1,015	TC072	T15	
T907	D100 d32 Z08 XNKT 08	100	32	8	52	1,575	TC072	T15	

Get information for cooling tool

Compatible with / Kompatible für (KRLY)

**90° XNKT 0604**

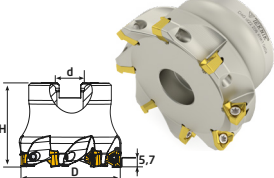

Order Code	Product Code	Dimensions (mm)					TC	T	KRLY
		D	d	Z	H	kg			
T852	D032 d16 Z04 XNKT 06	32	16	4	40	0,150	TC065-1	T8	
T853	D040 d16 Z06 XNKT 06	40	16	6	40	0,219	TC065-1	T8	XNKT 0604
T854	D050 d22 Z07 XNKT 06	50	22	7	40	0,348	TC065-1	T8	KRLY
T855	D063 d22 Z08 XNKT 06	63	22	8	40	0,527	TC065-1	T8	
T856	D080 d27 Z10 XNKT 06	80	27	10	50	0,938	TC065-1	T8	

Get information for cooling tool

Compatible with / Kompatible für (KRLY)

**WNMX 09T3**

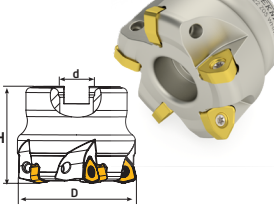

Order Code	Product Code	Dimensions (mm)					TC	T	KRLY
		D	d	Z	H	kg			
T669	D040 d16 Z04 WNMX 09	40	16	4	40	0,213	TC065	T8	
T670	D050 d22 Z05 WNMX 09	50	22	5	40	0,329	TC065	T8	WNMX 09T3
T671	D063 d22 Z06 WNMX 09	63	22	6	40	0,542	TC065	T8	KRLY
T671-1	D080 d27 Z06 WNMX 09	80	27	6	50	1,077	TC065	T8	
T671-2	D100 d32 Z07 WNMX 09	100	32	7	50	1,627	TC065	T8	

Get information for cooling tool

Compatible with / Kompatible für (KRLY)

**WNMX 1305**

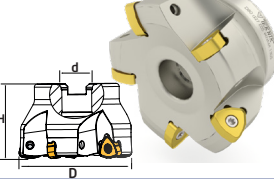

Order Code	Product Code	Dimensions (mm)					TC	T	KRLY
		D	d	Z	H	kg			
T687	D063 d22 Z04 WNMX 13 IK	63	22	4	50	0,752	TC074	T15	
T688	D080 d27 Z05 WNMX 13	80	27	5	50	1,040	TC074	T15	WNMX 1305
T689	D100 d32 Z06 WNMX 13	100	32	6	50	1,625	TC074	T15	KRLY
T690	D125 d40 Z07 WNMX 13	125	40	7	63	3,716	TC074	T15	

Get information for the T688-T690 cooled one.

Compatible with / Kompatible für (KRLY)

**LNMX 0603**

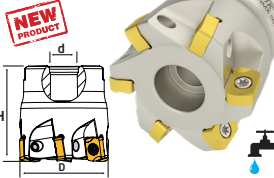

Order Code	Product Code	Dimensions (mm)					TC	T	KRLY
		D	d	Z	H	kg			
T835	D032 d16 Z05 LNMX 06 IK	32	16	5	40	0,173	TC065	T8	LNMX 0603
T836	D040 d16 Z06 LNMX 06 IK	40	16	6	40	0,279	TC065	T8	KRLY
T837	D050 d22 Z08 LNMX 06 IK	50	22	8	40	0,400	TC065	T8	
T838	D063 d22 Z09 LNMX 06 IK	63	22	9	40	0,766	TC065	T8	

Compatible with / Kompatible für (KRLY)

**RPMW 10T3**

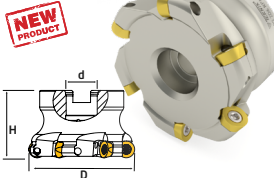

Order Code	Product Code	Dimensions (mm)					TC	T	KRLY
		D	d	Z	H	kg			
T706	D040 d16 Z05 RPMW 10	40	16	5	40	0,240	TC067	T15	
T707	D050 d22 Z06 RPMW 10	50	22	6	40	0,359	TC067	T15	RPMW 10T3
T708	D063 d22 Z06 RPMW 10 IK	63	22	6	40	0,584	TC067	T15	KRLY
T709	D080 d27 Z07 RPMW 10 IK	80	27	7	50	1,272	TC067	T15	

Get information for the T706 & T707 cooled one.

Compatible with / Kompatible für (KRLY)

RPMW 1204	Order Code	Product Code	Dimensions (mm)					kg			
			D	d	Z	H					
	T711	D050 d22 Z05 RPMW 12	50	22	5	40	0,327	TC073	T15		
	T712	D063 d22 Z05 RPMW 12	63	22	5	40	0,556	TC073	T15	RPMW 1204	
	T713	D080 d27 Z06 RPMW 12	80	27	6	50	0,584	TC073	T15	KRLY	
	T714	D100 d32 Z07 RPMW 12	100	32	7	53	1,278	TC073	T15		

Get information for cooling tool

Compatible with / Kompatible für (KRLY)

RPMW 1606	Order Code	Product Code	Dimensions (mm)					kg			
			D	d	Z	H					
	T717	D063 d22 Z05 RPMW 16 IK	63	22	5	40	0,509	TC083	T20		
	T718	D080 d27 Z06 RPMW 16 IK	80	27	6	50	1,048	TC083	T20	RPMW 1606	
	T719	D100 d32 Z07 RPMW 16 IK	100	32	7	55	0,584	TC083	T20	KRLY	
	T720	D125 d40 Z08 RPMW 16 IK	125	40	8	63	1,903	TC083	T20		

Compatible with / Kompatible für (KRLY)

90° XEKT 1904	Order Code	Product Code	Dimensions (mm)					kg			
			D	d	Z	H					
	T365	D40 d16 Z03 XEKT 19 IK	40	16	3	45	0,192	TC073	T15	XEKT 1904	
	T366	D50 d22 Z04 XEKT 19 IK	50	22	4	50	0,318	TC073	T15	XEKT 1904	
	T367	D63 d22 Z04 XEKT 19 IK	63	22	4	50	0,562	TC073	T15	XEKT 1904	
	T368	D80 d27 Z05 XEKT 19 IK	80	27	5	50	0,791	TC073	T15	XEKT 1904	
	T369	D100 d32 Z06 XEKT 19 IK	100	32	6	63	1,952	TC073	T15	XEKT 1904	
	T370	D125 d40 Z07 XEKT 19 IK	125	40	7	63	2,951	TC073	T15	XEKT 1904	

Compatible with / Kompatible für (KRLY)

90° APMT 0602	Order Code	Product Code	Dimensions (mm)					kg			
			D	d	Z	H					
	T596	D40 d16 Z10 APMT 06 IK	40	16	10	40	0,281	TC057-1	T6	APMT 0602	
	T597	D50 d22 Z12 APMT 06 IK	50	22	12	40	0,435	TC057-1	T6	KRLY	
	T598	D63 d22 Z14 APMT 06 IK	63	22	14	40	0,715	TC057-1	T6		
	T239	D40 d16 Z05 APMT 09	40	16	5	40	0,248	TC060	T8	APMT 0602	
	T240	D50 d22 Z06 APMT 09	50	22	6	40	0,348	TC060	T8	KRLY	

Get information for the T239 & T240 cooled one

Compatible with / Kompatible für (KRLY)

90° APMT 11T3	Order Code	Product Code	Dimensions (mm)					kg			
			D	d	Z	H					
	T250	D040 d16 Z05 APMT 11	40	16	5	40	0,220	TC060	T8		
	T252	D050 d22 Z06 APMT 11	50	22	6	40	0,332	TC060	T8	APMT 11T3	
	T254	D063 d22 Z07 APMT 11	63	22	7	40	0,483	TC060	T8	KRLY	
	T256	D080 d27 Z08 APMT 11	80	27	8	50	1,115	TC060	T8		
	T258	D100 d32 Z10 APMT 11	100	32	10	63	1,810	TC060	T8		

Get information for cooling tool

Compatible with / Kompatible für (KRLY)

90° APMT 1604	Order Code	Product Code	Dimensions (mm)					kg			
			D	d	Z	H					
	T241	D040 d16 Z04 APMT 16	40	16	4	45	0,258	TC074	T15		
	T243	D050 d22 Z05 APMT 16	50	22	5	45	0,400	TC074	T15	APMT 1604	
	T245	D063 d22 Z06 APMT 16	63	22	6	45	0,578	TC074	T15	KRLY	
	T247	D080 d27 Z07 APMT 16	80	27	7	52	1,249	TC074	T15		
	T249	D100 d32 Z08 APMT 16	100	32	8	52	1,530	TC074	T15		

Get information for cooling tool

Compatible with / Kompatible für (KRLY)

90° APXT 1003	Order Code	Product Code	Dimensions (mm)					kg			
			D	d	Z	H					
	T176	D040 d16 Z05 APXT 10	40	16	5	40	0,277	TC060	T8		
	T177	D050 d22 Z06 APXT 10	50	22	6	40	0,398	TC060	T8	APXT 1003	
	T178	D063 d22 Z07 APXT 10	63	22	7	40	0,543	TC060	T8	KRLY	
	T179	D080 d27 Z08 APXT 10	80	27	8	50	1,205	TC060	T8		

Get information for cooling tool

Compatible with / Kompatible für (KRLY)

90° AP-- 1604

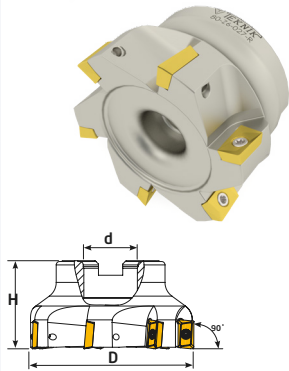

Order Code	Product Code	Dimensions (mm)					kg			
		D	d	Z	H					
T180	D040 d16 Z03 AP--16	40	16	3	45	0,267	TC074	T15		
T181	D040 d16 Z04 AP--16	40	16	4	45	0,258	TC074	T15		
T182	D050 d22 Z04 AP--16	50	22	4	45	0,406	TC074	T15		
T183	D050 d22 Z05 AP--16	50	22	5	45	0,400	TC074	T15		
T184	D063 d22 Z05 AP--16	63	22	5	45	0,577	TC074	T15		
T185	D063 d22 Z06 AP--16	63	22	6	45	0,578	TC074	T15	AP-- 1604	
T186	D080 d27 Z06 AP--16	80	27	6	52	1,159	TC074	T15	KRLY	
T187	D080 d27 Z07 AP--16	80	27	7	52	1,249	TC074	T15		
T188	D100 d32 Z07 AP--16	100	32	7	52	1,057	TC074	T15		
T189	D100 d32 Z08 AP--16	100	32	8	52	1,530	TC074	T15		
T190	D125 d40 Z09 AP--16	125	40	9	62	3,642	TC074	T15		
T192	D160 d40 Z10 AP--16	160	40	10	62	4,885	TC074	T15		
T193	D200 d60 Z12 AP--16	200	60	12	63	6,370	TC074	T15		
T195	D300 d60 Z15 AP--16	300	60	15	62	14,360	TC074	T15		

Get information for cooling tool

Compatible with / Kompatible für (KRLY)

AP-- 16 Chamfering Mill

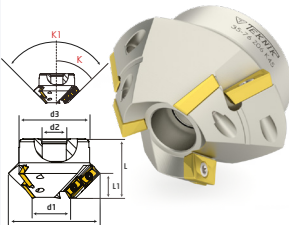

Order Code	Product Code	Dimensions (mm)										kg			
		K	K1	d1	D	Z	d2	d3	L	L1					
T457	35-50,5 Z06 K15° AP--16	15°	30°	35	50,5	6	22	45	60	30	0,415	TC074	T15		
T454	35-65 Z06 K30° AP--16	30°	60°	35	65	6	27	48	50	26,3	0,610	TC074	T15	AP-- 1604	
T456	35-76 Z06 K45° AP--16	45°	90°	35	76	6	27	60	50	21,5	0,734	TC074	T15	KRLY	
T455	35-86 Z06 K60° AP--16	60°	120°	35	86	6	27	60	50	15	0,892	TC074	T15		
T458	35-94 Z06 K75° AP--16	75°	150°	35	94	6	27	60	50	8,5	1,256	TC074	T15		

Get information for cooling tool

Compatible with / Kompatible für (KRLY)

F 75° AP-- 1604-APXT 1003

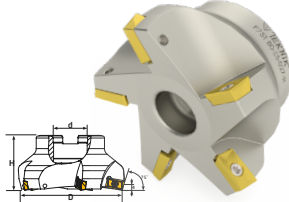

Order Code	Product Code	Dimensions (mm)					kg			
		D	d	Z	H					
T308	D063 d22 Z04 AP--16	63	22	4	45	0,510	TC074	T15		
T310	D080 d27 Z05 AP--16	80	27	5	52	1,120	TC074	T15	AP-- 1604	
T312	D100 d32 Z06 AP--16	100	32	6	52	1,587	TC074	T15	KRLY	
T313	D125 d40 Z07 AP--16	125	40	7	62	3,047	TC074	T15		
T452	D063 d22 Z06 APXT 10	63	22	6	45	0,630	TC063	T8	APXT 1003 KRLY	

Get information for cooling tool

Compatible with / Kompatible für (KRLY)

PNMU 1206

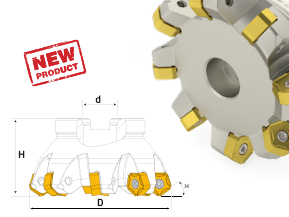

Order Code	Product Code	Dimensions (mm)					kg			
		D	d	Z	H					
T722	D050 d22 Z04 PNMU 12 IK	50	22	4	40	0,371	TC074	T15		
T723	D063 d22 Z05 PNMU 12 IK	63	22	5	40	0,594	TC074	T15	PNMU 1206	
T724	D080 d27 Z08 PNMU 12 IK	80	27	8	50	1,273	TC074	T15	YG1	
T725	D100 d32 Z10 PNMU 12 IK	100	32	10	50	1,901	TC074	T15		
T726	D125 d40 Z10 PNMU 12 IK	125	40	10	63	4,070	TC074	T15		

Compatible with / Kompatible für (YG1)

43° ODHT 0605

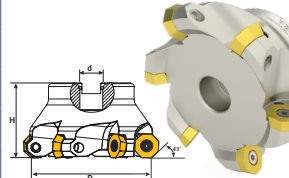

Order Code	Product Code	Dimensions (mm)					kg			
		D	d	Z	H					
T210	D063 d22 Z05 ODHT 06	63	22	5	40	0,610	TC083	T20	ODMT 06	
T211	D080 d27 Z06 ODHT 06	80	27	6	50	1,070	TC083	T20	YG1	
T212	D100 d32 Z07 ODHT 06	100	32	7	52	1,765	TC083	T20	ODHT 0605	
T213	D125 d40 Z08 ODHT 06	125	40	8	62	3,528	TC083	T20	WLTR	

Get information for cooling tool

Compatible with / Kompatible für (YG1-WLTR)

90° WNEX 0806

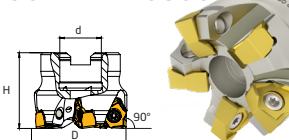

Order Code	Product Code	Dimensions (mm)					kg			
		D	d	Z	H					
T771	D050 d22 Z05 WNEX 08	50	22	5	40	0,285	TC074	T15	WNEX 0806	
T772	D063 d22 Z06 WNEX 08	63	22	6	40	0,451	TC074	T15	YG1	

Get information for cooling tool

Compatible with / Kompatible für (YG1)

### 100° ENMX 0604

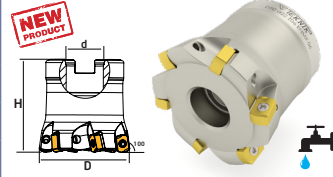

Order Code	Product Code	Dimensions (mm)					TC	T	Material
		D	d	Z	H	kg			
T763	D040 d16 Z06 ENMX 06 IK	40	16	6	40	0,261	TC063	T8	ENMX 0604
T764	D050 d22 Z06 ENMX 06 IK	50	22	6	50	0,478	TC063	T8	YG1
T765	D063 d22 Z07 ENMX 06 IK	63	22	7	50	0,762	TC063	T8	

*Compatible with / Kompatible für (YG1)*

### 100° ENMX 0905

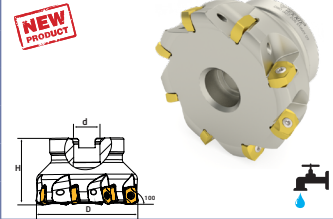

Order Code	Product Code	Dimensions (mm)					TC	T	Material
		D	d	Z	H	kg			
T701	D050 d22 Z04 ENMX 09 IK	50	22	4	50	0,487	TC069	T10	
T702	D063 d22 Z05 ENMX 09 IK	63	22	5	50	0,796	TC069	T10	ENMX 0905
T703	D080 d27 Z08 ENMX 09 IK	80	27	8	50	1,188	TC069	T10	YG1
T704	D100 d32 Z10 ENMX 09 IK	100	32	10	63	2,867	TC069	T10	
T705	D125 d40 Z12 ENMX 09 IK	125	40	12	63	4,186	TC069	T10	

*Compatible with / Kompatible für (YG1)*

### 90° APKT 1604

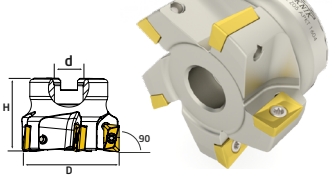

Order Code	Product Code	Dimensions (mm)					TC	T	Material
		D	d	Z	H	kg			
T767	D050 d22 Z04 APKT 16	50	22	4	45	0,381	TC074	T15	APKT 1604
T768	D063 d22 Z05 APKT 16	63	22	5	45	0,507	TC074	T15	YG1
T769	D080 d27 Z06 APKT 16	80	27	6	52	1,125	TC074	T15	

*Get information for cooling tool* *Compatible with / Kompatible für (YG1)*

### 45° SNMU 1305

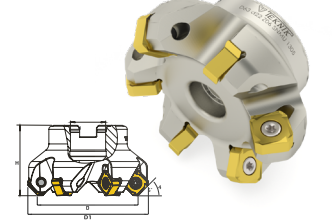

Order Code	Product Code	Dimensions (mm)					TC	T	Material	
		D	D1	d	Z	H				
T234	D050 d22 Z04 SNMU 13	50	63	22	4	44	0,480	TC083	T20	
T235	D063 d22 Z06 SNMU 13	63	76	22	6	44	0,645	TC083	T20	SNMU 1305
T236	D080 d27 Z07 SNMU 13	80	93	27	7	52	1,147	TC083	T20	ISCR
T237	D100 d32 Z08 SNMU 13	100	113	32	8	52	1,487	TC083	T20	
T238	D125 d40 Z10 SNMU 13	125	138	40	10	63	3,610	TC083	T20	

*Get information for cooling tool* *Compatible with / Kompatible für (ISCR)*

### 45° ONMU 0505

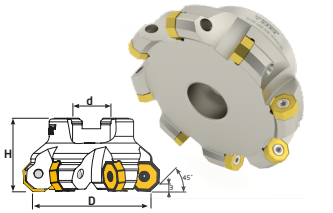

Order Code	Product Code	Dimensions (mm)					TC	T	Material
		D	d	Z	H	kg			
T794	D063 d22 Z06 ONMU 05	63	22	6	45	0,652	TC085	T20	
T796	D080 d27 Z07 ONMU 05	80	27	7	50	1,202	TC085	T20	ONMU 0505
T798	D100 d32 Z08 ONMU 05	100	32	8	52	1,842	TC085	T20	ISCR
T800	D125 d40 Z10 ONMU 05	125	40	10	62	3,537	TC085	T20	
T801	D160 d40 Z12 ONMU 05	160	40	12	62	4,863	TC085	T20	

*Get information for cooling tool* *Compatible with / Kompatible für (ISCR)*

### 90° WNMU 0705

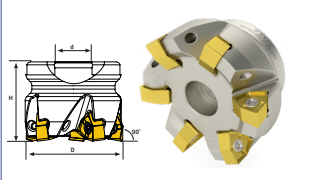

Order Code	Product Code	Dimensions (mm)					TC	T	Material
		D	d	Z	H	kg			
T392	D050 d22 Z05 WNMU 07 IK	50	22	5	40	0,337	TC074	T15	
T393	D063 d22 Z06 WNMU 07 IK	63	22	6	40	0,515	TC074	T15	WNMU 0705
T394	D080 d27 Z07 WNMU 07 IK	80	27	7	50	1,012	TC074	T15	ISC
T395	D100 d32 Z08 WNMU 07	100	32	8	50	1,342	TC074	T15	

*Get information for the T395 cooled one.* *Compatible with / Kompatible für (ISCR)*

### 90° ANKX 1205

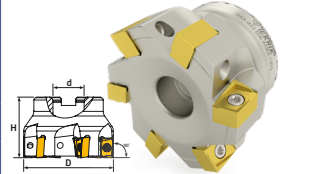

Order Code	Product Code	Dimensions (mm)					TC	T	Material
		D	d	Z	H	kg			
T571	D040 d16 Z04 ANKX 12	40	16	4	40	0,215	TC074	T15	
T572	D050 d22 Z05 ANKX 12	50	22	5	45	0,433	TC074	T15	ANKX 1205
T574	D063 d22 Z06 ANKX 12	63	22	6	45	0,596	TC074	T15	ISCR
T576	D080 d27 Z07 ANKX 12	80	27	7	50	1,210	TC074	T15	

*Get information for cooling tool* *Compatible with / Kompatible für (ISCR)*

90° ANKX 1706	Order Code	Product Code	Dimensions (mm)							
			D	d	Z	H				
	T440	D040 d16 Z03 ANKX 17	40	16	3	45	0,279	TC083	T20	
	T442	D050 d22 Z04 ANKX 17	50	22	4	45	0,371	TC083	T20	ANKX 1706
	T444	D063 d22 Z05 ANKX 17	63	22	5	45	0,573	TC083	T20	ISCR
	T446	D080 d27 Z06 ANKX 17	80	27	6	52	1,238	TC083	T20	
	T448	D100 d32 Z07 ANKX 17	100	32	7	52	2,029	TC083	T20	
	T450	D125 d40 Z08 ANKX 17	125	40	8	63	3,590	M5x12	T20	

Get information for cooling tool

Compatible with / Kompatibel für (ISCR)

90° LNMT 1306	Order Code	Product Code	Dimensions (mm)							
			D	d	Z	H				
	T228	D050 d22 Z05 LNMT 13	50	22	5	40	0,337	TC 074	T15	
	T229	D063 d22 Z06 LNMT 13	63	22	6	40	0,596	TC 074	T15	LNMT 1306
	T230	D080 d27 Z07 LNMT 13	80	27	7	50	1,227	TC 074	T15	ISCR
	T231	D100 d32 Z08 LNMT 13	100	32	8	50	1,682	TC 074	T15	
	T232	D125 d40 Z09 LNMT 13	125	40	9	63	3,325	TC 074	T15	
	T233	D160 d40 Z12 LNMT 13	160	40	12	63	5,046	TC 074	T15	

Get information for cooling tool

Compatible with / Kompatibel für (ISCR)

90° LNMT 0804	Order Code	Product Code	Dimensions (mm)							
			D	d	Z	H				
	T222	D040 d16 Z06 LNMT 08	40	16	6	40	0,240	TC061	T8	
	T223	D050 d22 Z07 LNMT 08	50	22	7	40	0,374	TC061	T8	LNMT 0804
	T224	D063 d22 Z09 LNMT 08	63	22	9	40	0,665	TC061	T8	ISCR
	T225	D080 d27 Z10 LNMT 08	80	27	10	50	1,145	TC061	T8	

Get information for cooling tool

Compatible with / Kompatibel für (ISCR)

90° ADKT 1505	Order Code	Product Code	Dimensions (mm)							
			D	d	Z	H				
	T200	D040 d16 Z04 ADKT 15	40	16	4	45	0,270	TC074	T15	
	T202	D050 d22 Z05 ADKT 15	50	22	5	45	0,394	TC074	T15	ADKT 1505
	T204	D063 d22 Z06 ADKT 15	63	22	6	45	0,565	TC074	T15	ISCR
	T206	D080 d27 Z07 ADKT 15	80	27	7	52	1,152	TC074	T15	
	T207	D100 d32 Z08 ADKT 15	100	32	8	52	1,546	TC074	T15	
	T208	D125 d40 Z09 ADKT 15	125	40	9	62	0,272	TC074	T15	

Get information for cooling tool

Compatible with / Kompatibel für (ISCR)

F 75° ADKT 1505	Order Code	Product Code	Dimensions (mm)							
			D	d	Z	H				
	T530	D063 d22 Z05 ADKT 15	63	22	5	45	0,580	TC074	T15	ADKT 1505
	T532	D080 d27 Z06 ADKT 15	80	27	6	50	1,090	TC074	T15	ISCR

Get information for cooling tool für (ISCR)

Compatible with / Kompatibel

55° HNHX 1006	Order Code	Product Code	Dimensions (mm)							
			D	d	Z	H				
	T470	D063 d22 Z05 HNHX 10	63	22	5	50	0,675	TC083	T20	
	T472	D080 d27 Z07 HNHX 10	80	27	7	50	1,063	TC083	T20	HNHX 1006
	T474	D100 d32 Z09 HNHX 10	100	32	9	62	2,023	TC083	T20	TGTC
	T476	D125 d40 Z10 HNHX 10	125	40	10	62	3,331	TC083	T20	
	T478	D160 d40 Z12 HNHX 10	160	40	12	62	4,724	TC083	T20	

Get information for cooling tool

Compatible with / Kompatibel für (TGTC)

90° SPMG 0904	Order Code	Product Code	Dimensions (mm)							
			D	d	Z	H				
	T338	D050 d22 Z05 SPMG 09	50	22	5	45	0,239	TC067	T15	SPMG 0904
	T340	D063 d22 Z06 SPMG 09	63	22	6	45	0,362	TC067	T15	TGTC
	T342	D080 d27 Z07 SPMG 09	80	27	7	52	1,088	TC067	T15	

Get information for cooling tool

Compatible with / Kompatibel für (TGTC)

90° 3PKT 1505	Order Code	Product Code	Dimensions (mm)							
			D	d	Z	H				
	T398	D050 d22 Z05 3PKT 15	50	22	5	40	0,325	TC074	T15	
	T399	D063 d22 Z06 3PKT 15	63	22	6	40	0,490	TC074	T15	3PKT 1505
	T400	D080 d27 Z07 3PKT 15	80	27	7	50	1,105	TC074	T15	TGTC

Get information for cooling tool

Compatible with / Kompatible für (TGTC)

100° BLMP 0603	Order Code	Product Code	Dimensions (mm)							
			D	d	Z	H				
	T480	D040 d16 Z06 BLMP 06	40	16	6	45	0,262	TC064	T8	BLMP 0603
	T481	D050 d22 Z07 BLMP 06	50	22	7	50	0,457	TC064	T8	TGTC
	T482	D052 d22 Z07 BLMP 06	52	22	7	50	0,472	TC064	T8	

Get information for cooling tool für (TGTC)

Compatible with / Kompatible

100° BLMP 0904	Order Code	Product Code	Dimensions (mm)							
			D	d	Z	H				
	T485	D040 d16 Z05 BLMP 09	40	16	5	40	0,176	TC069	T10	
	T486	D052 d22 Z06 BLMP 09	52	22	6	50	0,427	TC069	T10	BLMP 0904
	T487	D063 d22 Z07 BLMP 09	63	22	7	50	0,615	TC069	T10	TGTC
	T487-2	D066 d22 Z07 BLMP 09	66	22	7	50	0,675	TC069	T10	
	T487-3	D080 d27 Z08 BLMP 09	80	27	8	50	1,238	TC069	T10	
	T487-5	D100 d32 Z09 BLMP 09	100	32	9	60	2,320	TC069	T10	

Get information for cooling tool

Compatible with / Kompatible für (TGTC)

90° APKT 1705	Order Code	Product Code	Dimensions (mm)							
			D	d	Z	H				
	T550	D040 d16 Z04 APKT 17	40	16	4	45	0,239	TC074	T15	
	T552	D050 d22 Z05 APKT 17	50	22	5	45	0,362	TC074	T15	APKT 1705
	T554	D063 d22 Z06 APKT 17	63	22	6	45	0,520	TC074	T15	TGTC
	T556	D080 d27 Z07 APKT 17	80	27	7	50	1,047	TC074	T15	
	T558	D100 d32 Z08 APKT 17	100	32	8	52	1,620	TC074	T15	

Get information for cooling tool

Compatible with / Kompatible für (TGTC)

LNMU 0303	Order Code	Product Code	Dimensions (mm)							
			D	d	Z	H				
	T728	D040 d16 Z06 LNMU 03	40	16	6	40	0,275	TC063	T8	LNMU 0303
	T729	D050 d22 Z07 LNMU 03	50	22	7	50	0,541	TC063	T8	TNGLY - OKE
	T730	D063 d22 Z09 LNMU 03	63	22	9	50	0,766	TC063	T8	

Get information for cooling tool

Compatible with / Kompatible für (TNGLY - OKE)

90° XNEX 0806	Order Code	Product Code	Dimensions (mm)							
			D	d	Z	H				
	T840	D050 d22 Z04 XNEX 08	50	22	4	45	0,400	TC076	T15	
	T841	D050 d22 Z05 XNEX 08	50	22	5	45	0,394	TC076	T15	SCO.
	T842	D063 d22 Z06 XNEX 08	63	22	6	45	0,490	TC076	T15	XNEX 0806 SCO
	T844	D080 d27 Z07 XNEX 08	80	27	7	50	1,063	TC076	T15	XNEX 0806
	T846	D100 d32 Z07 XNEX 08	100	32	7	52	1,755	TC076	T15	WNST
	T848	D125 d40 Z10 XNEX 08	125	40	10	60	3,155	TC076	T15	
	T850	D160 d40 Z12 XNEX 08	160	40	12	63	5,154	TC076	T15	
	T851	D200 d60 Z14 XNEX 08	200	60	14	63	6,415	TC076	T15	

Get information for cooling tool

Compatible with / Kompatible für (SCO - WNS)

90° LOEX 1207	Order Code	Product Code	Dimensions (mm)							
			D	d	Z	H				
	T586	D050 d22 Z05 LOEX12	50	22	5	40	0,358	TC074	T15	LOEX 1207
	T587	D063 d22 Z06 LOEX12	63	22	6	40	0,604	TC074	T15	SCO
	T588	D080 d27 Z07 LOEX12	80	27	7	50	1,029	TC074	T15	

Get information for cooling tool

Compatible with / Kompatible für (SCO)

90° XOMX 1204	Order Code	Product Code	Dimensions (mm)							
			D	d	Z	H				
	T510	D040 d16 Z04 XOMX 12	40	16	4	40	0,250	TC069	T10	
	T512	D050 d22 Z05 XOMX 12	50	22	5	40	0,351	TC069	T10	
	T514	D063 d22 Z06 XOMX 12	63	22	6	40	0,618	TC069	T10	XOMX 1204
	T516	D080 d27 Z07 XOMX 12	80	27	7	50	1,155	TC069	T10	SCO
	T518	D100 d32 Z10 XOMX 12	100	32	10	52	1,817	TC069	T10	
	T519	D125 d40 Z12 XOMX 12	125	40	12	62	3,565	TC069	T10	

Get information for cooling tool

Compatible with / Kompatible für (SCO)

90° XOMX 1806	Order Code	Product Code	Dimensions (mm)							
			D	d	Z	H				
	T520	D050 d22 Z05 XOMX 18	50	22	5	45	0,337	TC080	T15	
	T522	D063 d22 Z06 XOMX 18	63	22	6	45	0,550	TC080	T15	
	T524	D080 d27 Z07 XOMX 18	80	27	7	50	1,082	TC080	T15	XOMX 1806
	T525	D100 d32 Z08 XOMX 18	100	32	8	52	1,661	TC080	T15	SCO
	T526	D125 d40 Z09 XOMX 18	125	40	9	62	3,427	TC080	T15	
	T527	D160 d40 Z10 XOMX 18	160	40	10	62	4,831	TC080	T15	

Get information for cooling tool

Compatible with / Kompatible für (SCO)

45° SEET 12T3 R245	Order Code	Product Code	Dimensions (mm)							
			D	d	Z	H				
	T435	D063 d22 Z05 SEET 12	63	22	5	50	0,815	TC067	T15	
	T436	D080 d27 Z06 SEET 12	80	27	6	52	1,305	TC067	T15	SEET 12T3
	T437	D100 d32 Z07 SEET 12	100	32	7	55	1,715	TC067	T15	R245
	T438	D125 d40 Z08 SEET 12	125	40	8	62	3,427	TC067	T15	

Get information for cooling tool

Compatible with / Kompatible für (ZCC -SNDVK-XTC)

With Shim - Mit U-Platte

45° SEET 12T3 R245	Order Code	Product Code	Dimensions (mm)									
			D	d	Z	H						
	T560	D050 d22 Z04 SEET 12	50	22	4	40	0,345	TC068	TA052	TC049	T15	
	T562	D063 d22 Z05 SEET 12	63	22	5	40	0,505	TC068	TA052	TC049	T15	SEET 12T3
	T564	D080 d27 Z06 SEET 12	80	27	6	50	1,206	TC068	TA052	TC049	T15	R245
	T566	D100 d32 Z07 SEET 12	100	32	7	50	1,812	TC068	TA052	TC049	T15	
	T568	D125 d40 Z08 SEET 12	125	40	8	63	3,390	TC068	TA052	TC049	T15	
	T570	D160 d40 Z10 SEET 12	160	40	10	63	4,590	TC068	TA052	TC049	T15	

Get information for cooling tool

Compatible with / Kompatible für (ZCC -SNDVK-XTC)

RCKT 1204	Order Code	Product Code	Dimensions (mm)							
			D	d	Z	H				
	T460	D050 d22 Z04 RCKT 12	50	22	4	40	0,287	TC067	T15	
	T462	D063 d22 Z05 RCKT 12	63	22	5	40	0,436	TC067	T15	RCKT 1204
	T464	D080 d27 Z06 RCKT 12	80	27	6	50	1,088	TC067	T15	SNDVK
	T466	D100 d32 Z07 RCKT 12	100	32	7	52	1,608	TC067	T15	

Get information for cooling tool

Compatible with / Kompatible für (SNDVK)

90° R390-11T3	Order Code	Product Code	Dimensions (mm)							
			D	d	Z	H				
	T577	D040 d16 Z05 R390 11	40	16	5	40	0,225	TC063	T8	R390-11T3
	T578	D050 d22 Z06 R390 11	50	22	6	40	0,355	TC063	T8	SNDVK
	T579	D063 d22 Z07 R390 11	63	22	7	40	0,503	TC063	T8	

Get information for cooling tool

Compatible with / Kompatible für (SNDVK)

90° R390-1704	Order Code	Product Code	Dimensions (mm)							
			D	d	Z	H				
	T402	D040 d16 Z04 R390 17	40	16	4	45	0,276	TC067	T15	
	T404	D050 d22 Z05 R390 17	50	22	5	45	0,591	TC067	T15	
	T408	D063 d22 Z06 R390 17	63	22	6	45	0,590	TC067	T15	R390-1704
	T411	D080 d27 Z07 R390 17	80	27	7	52	1,168	TC067	T15	SNDVK
	T412	D100 d32 Z08 R390 17	100	32	8	52	1,665	TC067	T15	
	T414	D125 d40 Z09 R390 17	125	40	9	62	3,680	TC067	T15	
	T416	D160 d40 Z10 R390 17	160	40	10	62	5,010	TC067	T15	

Get information for cooling tool

Compatible with / Kompatible für (SNDVK)

90° R390-1806	Order Code	Product Code	Dimensions (mm)							
			D	d	Z	H				
	T423	D050 d22 Z04 R390 18	50	22	4	45	0,303	TC074	T15	
	T424	D063 d22 Z05 R390 18	63	22	5	45	0,490	TC074	T15	R390-1806
	T426	D080 d27 Z06 R390 18	80	27	6	52	1,081	TC074	T15	SNDVK
	T428	D100 d32 Z07 R390 18	100	32	7	52	1,595	TC074	T15	
	T430	D125 d40 Z08 R390 18	125	40	8	62	3,558	TC074	T15	
	T432	D160 d40 Z10 R390 18	160	40	10	62	4,411	TC074	T15	

Get information for cooling tool

Compatible with / Kompatible für (SNDVK)

45° SNEU 1206	Order Code	Product Code	Dimensions (mm)								
			D	D1	d	Z	H				
	T164	D050 d22 Z05 SNEU 12	50	63	22	5	40	0,447	TC083	T20	
	T165	D063 d22 Z06 SNEU 12	63	76	22	6	40	0,582	TC083	T20	SNEU 1206
	T166	D080 d27 Z07 SNEU 12	80	93	27	7	50	1,252	TC083	T20	
	T167	D100 d32 Z08 SNEU 12	100	113	32	8	50	1,925	TC083	T20	
	T168	D125 d40 Z10 SNEU 12	125	138	40	10	63	3,516	TC083	T20	

Get information for cooling tool

Compatible with / Kompatible für (XTC-GSC-WLTR)

90° LNGX 1307	Order Code	Product Code	Dimensions (mm)							
			D	d	Z	H				
	T488	D040 d16 Z03 LNGX 13	40	16	3	45	0,304	TC079	T15	
	T490	D050 d22 Z04 LNGX 13	50	22	4	45	0,425	TC079	T15	
	T492	D063 d22 Z06 LNGX 13	63	22	6	45	0,560	TC079	T15	LNGX 1307
	T493	D080 d27 Z07 LNGX 13	80	27	7	50	1,124	TC079	T15	WLTR
	T494	D100 d32 Z07 LNGX 13	100	32	7	50	1,542	TC079	T15	
	T495	D125 d40 Z08 LNGX 13	125	40	8	63	3,555	TC079	T15	

Get information for cooling tool

Compatible with / Kompatible für (WLTR)

90° LNHU 1306	Order Code	Product Code	Dimensions (mm)							
			D	d	Z	H				
	T580	D050 d22 Z05 LNHU 13	50	22	5	40	0,350	TC079	T15	
	T581	D063 d22 Z06 LNHU 13	63	22	6	40	0,628	TC079	T15	LNHU 1306
	T582	D080 d27 Z07 LNHU 13	80	27	7	50	1,315	TC079	T15	WLTR
	T583	D100 d32 Z08 LNHU 13	100	32	8	50	1,795	TC079	T15	

Get information for cooling tool

Compatible with / Kompatible für (WLTR)

90° ADMT 1204	Order Code	Product Code	Dimensions (mm)							
			D	d	Z	H				
	T214	D040 d16 Z04 ADMT 12	40	16	4	45	0,280	TC065	T8	
	T215	D050 d22 Z05 ADMT 12	50	22	5	45	0,350	TC065	T8	ADMT 1204
	T217	D063 d22 Z06 ADMT 12	63	22	6	45	0,610	TC065	T8	WLTR
	T219	D080 d27 Z07 ADMT 12	80	27	7	52	1,176	TC065	T8	
	T220	D100 d32 Z08 ADMT 12	100	32	8	52	1,595	TC065	T8	

Get information for cooling tool

Compatible with. / Kompatible für (WLTR)

90° ADMT 1606	Order Code	Product Code	Dimensions (mm)							
			D	d	Z	H				
	T351	D040 d16 Z04 ADMT 16	40	16	4	45	0,258	TC072	T15	
	T352	D050 d22 Z05 ADMT 16	50	22	5	45	0,397	TC072	T15	ADMT 1606
	T354	D063 d22 Z06 ADMT 16	63	22	6	45	0,578	TC072	T15	WLTR
	T356	D080 d27 Z07 ADMT 16	80	27	7	52	1,254	TC072	T15	
	T357	D100 d32 Z07 ADMT 16	100	32	7	50	1,612	TC072	T15	

Get information for cooling tool

Compatible with. / Kompatible für (WLTR)

45° SNKX 1206- ONHX 0505	Order Code	Product Code	Dimensions (mm)								
			D	D1	d	Z	H				
	T623	D050 d22 Z04 SNKX 12 ONHX 05 IK	50	42,4	22	4	40	0,458	TC074	T15	
	T624	D063 d22 Z06 SNKX 12 ONHX 05 IK	63	55,4	22	6	40	0,608	TC074	T15	SNKX 1206
	T625	D080 d27 Z07 SNKX 12 ONHX 05 IK	80	72,4	27	7	50	1,051	TC074	T15	ONHX 0505
	T626	D100 d32 Z08 SNKX 12 ONHX 05 IK	100	92,4	32	8	50	1,813	TC074	T15	PLBT
	T627	D125 d40 Z10 SNKX 12 ONHX 05 IK	125	117,4	40	10	63	3,277	TC074	T15	
	T628	D160 d40 Z12 SNKX 12 ONHX 05	160	152,4	40	12	63	4,577	TC074	T15	

Get information for the T628 cooled one.

Compatible with /Kompatible für (PLBT)

45° SNKX 1606- ONHX 0606	Order Code	Product Code	Dimensions (mm)								
			D	D1	d	Z	H				
	T628-1	D050 d22 Z04 SNKX 16 ONHX 06 IK	50	63	22	4	48	0,458	TC083	T20	
	T629	D063 d22 Z05 SNKX 16 ONHX 06 IK	63	76	22	5	50	0,776	TC083	T20	
	T630	D080 d27 Z06 SNKX 16 ONHX 06 IK	80	93	27	6	50	2,013	TC083	T20	SNKX 1606
	T631	D100 d32 Z07 SNKX 16 ONHX 06 IK	100	117	32	7	63	2,750	TC083	T20	ONHX 0606
	T632	D125 d40 Z08 SNKX 16 ONHX 06 IK	125	138	40	8	63	4,026	TC083	T20	PLBT
	T633	D160 d40 Z10 SNKX 16 ONHX 06	160	173	40	10	63	4,712	TC083	T20	
	T634	D200 d60 Z12 SNKX 16 ONHX 06	200	217	60	12	63	8,112	TC083	T20	

Get information for the T633 & T634 cooled one.

Compatible with /Kompatible für (PLBT)

88° SNHU 1206	Order Code	Product Code	Dimensions (mm)							
			D	d	Z	H				
	T617	D050 d22 Z05 SNHU 12 IK	50	22	5	40	0,305	TC074	T15	
	T618	D063 d22 Z06 SNHU 12 IK	63	22	6	40	0,503	TC074	T15	
	T619	D080 d27 Z07 SNHU 12 IK	80	27	7	50	1,076	TC074	T15	SNHU 1206
	T620	D100 d32 Z08 SNHU 12 IK	100	32	8	50	1,459	TC074	T15	PLBT
	T621	D125 d40 Z10 SNHU 12 IK	125	40	10	63	2,708	TC074	T15	
	T622	D160 d40 Z12 SNHU 12	160	40	12	63	4,328	TC074	T15	

Get information for the T622 cooled one.

Compatible with / Kompatible für (PLBT)

90° SPMT 1204	Order Code	Product Code	Dimensions (mm)							
			D	d	Z	H				
	T649	D040 d16 Z03 SPMT 12	40	16	3	40	0,253	TC083	T20	
	T650	D050 d22 Z04 SPMT 12	50	22	4	40	0,362	TC083	T20	SPMT 1204
	T651	D063 d22 Z05 SPMT 12	63	22	5	50	0,772	TC083	T20	PLBT
	T652	D080 d27 Z06 SPMT 12	80	27	6	50	1,186	TC083	T20	
	T653	D100 d32 Z08 SPMT 12	100	32	8	50	1,786	TC083	T20	ZCC
	T654	D125 d40 Z08 SPMT 12	125	40	8	63	2,935	TC083	T20	WLTR
	T655	D160 d40 Z10 SPMT 12	160	40	10	63	3,980	TC083	T20	

Get information for cooling tool

Compatible with / Kompatible für (PLBT -ZCC-WLTR)

90° ANHX 1004	Order Code	Product Code	Dimensions (mm)							
			D	d	Z	H				
	T656	D040 d16 Z04 ANHX 10 IK	40	16	4	40	0,250	TC065	T8	
	T657	D050 d22 Z05 ANHX 10 IK	50	22	5	40	0,374	TC065	T8	ANHX 1004
	T658	D063 d22 Z07 ANHX 10 IK	63	22	7	40	0,638	TC065	T8	PLBT
	T659	D080 d27 Z08 ANHX 10 IK	80	27	8	50	1,132	TC065	T8	
<i>Compatible with / Kompatible für (PLBT)</i>										

90° ANHX 1206	Order Code	Product Code	Dimensions (mm)							
			D	d	Z	H				
	T641	D040 d16 Z04 ANHX 12 IK	40	16	4	40	0,248	TC069	T10	
	T642	D050 d22 Z05 ANHX 12 IK	50	22	5	40	0,375	TC069	T10	
	T643	D063 d22 Z05 ANHX 12 IK	63	27	5	40	0,619	TC069	T10	ANHX 1206
	T644	D080 d27 Z08 ANHX 12 IK	80	27	8	50	1,209	TC069	T10	PLBT
	T645	D100 d32 Z12 ANHX 12 IK	100	32	12	50	1,761	TC069	T10	
	T646	D125 d40 Z14 ANHX 12 IK	125	40	14	63	3,091	TC069	T10	
<i>Compatible with / Kompatible für (PLBT)</i>										

90° LNXT 1306	Order Code	Product Code	Dimensions (mm)							
			D	d	Z	H				
	T672	D040 d16 Z04 LNXT 13 IK	40	16	4	40	0,225	TC074	T15	
	T673	D050 d22 Z05 LNXT 13 IK	50	22	5	40	0,358	TC074	T15	LNXT 1306
	T674	D063 d22 Z06 LNXT 13 IK	63	22	6	40	0,604	TC074	T15	PLBT
	T675	D080 d27 Z07 LNXT 13 IK	80	27	7	50	1,029	TC074	T15	
	T676	D100 d32 Z08 LNXT 13 IK	100	32	8	50	1,733	TC074	T15	
<i>Compatible with. / Kompatible für (PLBT)</i>										

RNHX 1204	Order Code	Product Code	Dimensions (mm)							
			D	d	Z	H				
	T661	D050 d22 Z05 RNHX 12 IK	50	22	5	40	0,284	TC074	T15	RNHX 1204
	T662	D063 d22 Z06 RNHX 12 IK	63	22	6	50	0,637	TC074	T15	PLBT
	T664	D100 d32 Z08 RNHX 12 IK	100	32	8	50	1,570	TC074	T15	
<i>Kompatible für (PLBT)      Compatible with /</i>										

RDMT 12T3	Order Code	Product Code	Dimensions (mm)								
			D	d	Z	H					
	T667	D052 d22 Z05 RDMT 12 IK	52	22	5	50	0,403	TC067	TC040	T15	RDMT 12T3
	T668-1	D066 d27 Z06 RDMT 12 IK	66	27	6	50	0,670	TC067	TC040	T15	PLBT
	T668	D080 d27 Z07 RDMT 12 IK	80	27	7	50	1,181	TC067	TC040	T15	
<i>Compatible with / Kompatible für (PLBT)</i>											

90° WNMU 0806	Order Code	Product Code	Dimensions (mm)							
			D	d	Z	H				
	T543	D050 d22 Z03 WNMU 08	50	22	3	46	0,360	TC083	T20	
	T544	D063 d22 Z04 WNMU 08	63	22	4	46	0,556	TC083	T20	WNMU 0806
	T545	D080 d27 Z05 WNMU 08	80	27	5	50	1,016	TC083	T20	KYCRA
	T546	D100 d32 Z06 WNMU 08	100	32	6	50	1,360	TC083	T20	
<i>Get information for cooling tool      Compatible with. / Kompatible für (KYCRA)</i>										

LOGU 0303	Order Code	Product Code	Dimensions (mm)							
			D	d	Z	H				
	T731	D040 d16 Z06 LOGU 03	40	16	6	40	0,283	TC064-2	T8	LOGU 0303
	T732	D050 d22 Z07 LOGU 03	50	22	7	50	0,582	TC064-2	T8	KYCR
	T734	D063 d22 Z09 LOGU 03	63	22	9	50	1,188	TC064-2	T8	
<i>Get information for cooling tool      Compatible with. / Kompatible für (KYCRA)</i>										

90° BDMT 11T3	Order Code	Product Code	Dimensions (mm)							
			D	d	Z	H				
	T533	D040 d16 Z05 BDMT 11	40	16	5	40	0,224	TC060	T8	BDMT 11T3
	T534	D050 d22 Z06 BDMT 11	50	22	6	40	0,361	TC060	T8	KYCRA
	T535	D063 d22 Z07 BDMT 11	63	22	7	40	0,527	TC060	T8	

Get information for cooling tool Compatible with. / Kompatible für (KYCRA)

90° BDMT 1704	Order Code	Product Code	Dimensions (mm)							
			D	d	Z	H				
	T537	D040 d16 Z04 BDMT 17	40	16	4	40	0,190	TC074	T15	
	T538	D050 d22 Z05 BDMT 17	50	22	5	40	0,312	TC074	T15	BDMT 1704
	T539	D063 d22 Z06 BDMT 17	63	22	6	40	0,516	TC074	T15	KYCRA
	T540	D080 d27 Z07 BDMT 17	80	27	7	50	1,165	TC074	T15	

Get information for cooling tool Compatible with. / Kompatible für (KYCRA)

SDMT 09T3	Order Code	Product Code	Dimensions (mm)							
			D	d	Z	H				
	T362	D040 d16 Z04 SDMT 09	40	16	4	40	0,215	TC067	T15	SDMT 09T3
	T363	D050 d22 Z05 SDMT 09	50	22	5	40	0,355	TC067	T15	ZCC
	T364	D063 d22 Z06 SDMT 09	63	22	6	40	0,592	TC067	T15	

Get information for cooling tool Compatible with. / Kompatible für (ZCC)

SDMT 1204	Order Code	Product Code	Dimensions (mm)							
			D	d	Z	H				
	T358	D050 d22 Z04 SDMT 12	50	22	4	40	0,315	TC074	T15	SDMT 1204
	T359	D063 d22 Z05 SDMT 12	63	22	5	40	0,422	TC074	T15	ZCC
	T360	D080 d27 Z06 SDMT 12	80	27	6	52	1,051	TC074	T15	

Get information for cooling tool Compatible with. / Kompatible für (ZCC)

RHKW 0802	Order Code	Product Code	Dimensions (mm)								
			D	d	Z	H					
	T599	D040 d16 Z04 RHKW 08	40	16	4	40	0,247	TC040	TC065-1	T15	RHKW 0802
	T600	D050 d22 Z05 RHKW 08	50	22	5	40	0,309	TC040	TC065-1	T15	INGRSL
	T601	D063 d22 Z06 RHKW 08	63	22	6	40	0,530	TC040	TC065-1	T15	

Get information for cooling tool Compatible with. / Kompatible für (INGRSL)

RHKW 1003	Order Code	Product Code	Dimensions (mm)								
			D	d	Z	H					
	T602	D040 d16 Z04 RHKW 10	40	16	4	40	0,243	TC040	TC074	T15	RHKW 1003
	T604	D050 d22 Z05 RHKW 10	50	22	5	40	0,289	TC040	TC074	T15	INGRSL
	T606	D063 d22 Z06 RHKW 10	63	22	6	40	0,488	TC040	TC074	T15	
	T608	D080 d27 Z07 RHKW 10	80	27	7	50	1,080	TC040	TC074	T15	

Get information for cooling tool Compatible with. / Kompatible für (INGRSL)

RHKW 1204	Order Code	Product Code	Dimensions (mm)								
			D	d	Z	H					
	T612	D040 d16 Z04 RHKW 12	40	16	4	40	0,246	TC040	TC074	T15	RHKW 1204
	T613	D050 d22 Z05 RHKW 12	50	22	5	40	0,304	TC040	TC074	T15	INGRSL
	T614	D063 d22 Z06 RHKW 12	63	22	6	40	0,556	TC040	TC074	T15	
	T615	D080 d27 Z07 RHKW 12	80	27	7	50	1,039	TC040	TC074	T15	

Get information for cooling tool Compatible with. / Kompatible für (INGRSL)

### 90° BOMT 1304

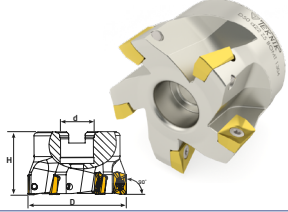

Order Code	Product Code	Dimensions (mm)					TC	T	ISO
		D	d	Z	H	kg			
T965	D040 d16 Z04 BOMT 13	40	16	4	40	0,272	TC069	T10	BOMT 1304
T966	D050 d22 Z05 BOMT 13	50	22	5	40	0,369	TC069	T10	INGRSLL
T967	D063 d22 Z06 BOMT 13	63	22	6	40	0,613	TC069	T10	

Get information for cooling tool

Compatible with. / Kompatible für (INGRSLL)

### 55° HNGX 0906

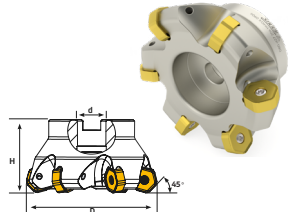

Order Code	Product Code	Dimensions (mm)					TC	T	ISO
		D	d	Z	H	kg			
T418	D063 d22 Z06 HNGX 09	63	22	6	40	0,518	TC080	T15	
T419	D080 d27 Z06 HNGX 09	80	27	6	50	1,067	TC080	T15	HNGX 0906
T420	D100 d32 Z08 HNGX 09	100	32	8	50	1,542	TC080	T15	PRMT
T421	D125 d40 Z08 HNGX 09	125	40	8	63	3,314	TC080	T15	
T422	D160 d40 Z12 HNGX 09	160	40	12	63	3,962	TC080	T15	

Get information for cooling tool

Compatible with. / Kompatible für (PRMT)

### ZDEW 1204

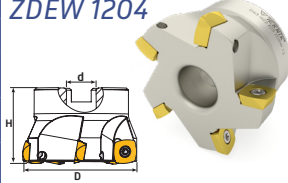

Order Code	Product Code	Dimensions (mm)					TC	T	ISO
		D	d	Z	H	kg			
T196	D050 d22 Z04 ZDEW 12	50	22	4	40	0,256	TC080-1	T15	ZDEW 1204
T197	D063 d22 Z05 ZDEW 12	63	22	5	40	0,474	TC080-1	T15	PRMT

Get information for cooling tool

Compatible with. / Kompatible für (PRMT)

### 45° SDHT 1204

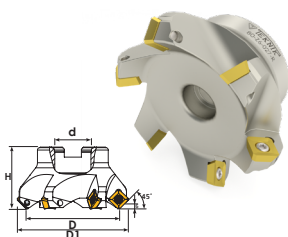

Order Code	Product Code	Dimensions (mm)					TC	T	ISO	
		D	D1	d	Z	H				kg
T300	D063 d22 Z05 SDHT 12	63	77	22	5	45	0,630	TC080	T15	
T302	D080 d27 Z06 SDHT 12	80	94	27	6	52	1,200	TC080	T15	SDHT 1204
T304	D100 d32 Z07 SDHT 12	100	114	32	7	62	2,040	TC080	T15	ISO
T305	D125 d40 Z08 SDHT 12	125	139	40	8	62	4,095	TC080	T15	

### 90° VCGT 1604

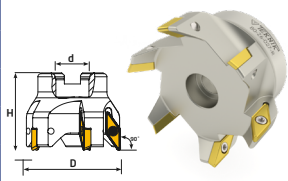

Order Code	Product Code	Dimensions (mm)					TC	T	ISO
		D	d	Z	H	kg			
T498	D040 d16 Z03 VCGT 16	40	16	3	52	0,277	TC074	T15	
T500	D050 d22 Z04 VCGT 16	50	22	4	52	0,362	TC074	T15	VCGT 1604
T502	D063 d22 Z05 VCGT 16	63	22	5	52	0,538	TC074	T15	ISO
T504	D080 d27 Z06 VCGT 16	80	27	6	52	0,848	TC074	T15	

### 43° OFCR 0704

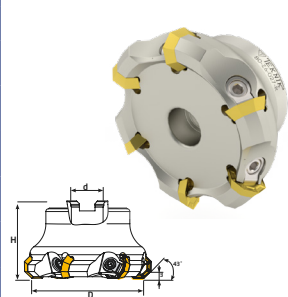

Order Code	Product Code	Dimensions (mm)					TC	T	ISO	
		D	d	Z	H	kg				
T260	D050 d22 Z04 OFCR 07	50	22	4	45	0,488	BK300	TC300 M8x18	4 Allen	
T262	D063 d22 Z04 OFCR 07	63	22	4	45	0,722	BK300	TC300 M8x18	4 Allen	OFCR 0704
T264	D080 d27 Z06 OFCR 07	80	27	6	50	1,205	BK300	TC300 M8x18	4 Allen	ISO
T266	D100 d32 Z08 OFCR 07	100	32	8	50	1,654	BK300	TC300 M8x18	4 Allen	
T268	D125 d40 Z09 OFCR 07	125	40	9	62	3,510	BK300	TC300 M8x18	4 Allen	
T269	D160 d40 Z12 OFCR 07	160	40	12	62	5,112	BK300	TC300 M8x18	4 Allen	

### 90° ANKX 1607

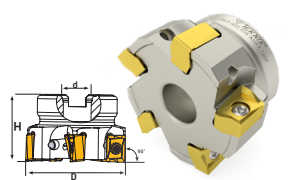

Order Code	Product Code	Dimensions (mm)					TC	T	ISO
		D	d	Z	H	kg			
T171	D050 d22 Z04 ANKX 16	50	22	4	40	0,307	TC080-1	T15	
T172	D063 d22 Z05 ANKX 16	63	22	5	40	0,462	TC080-1	T15	ANKX 1607
T173	D080 d27 Z06 ANKX 16	80	27	6	50	1,101	TC080-1	T15	

Get information for cooling tool (XTC- GSC)

Compatible with / Kompatible für

90° LNGU 15T6	Order Code	Product Code	Dimensions (mm)							
			D	d	Z	H				
	T956	D050 d22 Z05 LNGU 15	50	22	5	40	0,305	TC074	T15	
	T958	D063 d22 Z06 LNGU 15	63	22	6	40	0,541	TC074	T15	LNGU 15T6
	T960	D080 d27 Z07 LNGU 15	80	27	7	50	1,133	TC074	T15	KNNMTL
	T961	D100 d32 Z08 LNGU 15	100	32	8	50	1,933	TC074	T15	

Get information for cooling tool

Compatible with. / Kompatible für (KNNMTL)

RDMT 1003	Order Code	Product Code	Dimensions (mm)								
			D	d	Z	H					
	T288	D040 d16 Z03 RDMT 10	40	16	3	40	0,208	TC067	TC040	T15	
	T289	D040 d16 Z04 RDMT 10	40	16	4	40	0,220	TC067	TC040	T15	
	T290	D050 d22 Z04 RDMT 10	50	22	4	40	0,310	TC067	TC040	T15	
	T291	D050 d22 Z05 RDMT 10	50	22	5	40	0,302	TC067	TC040	T15	RDMT 1003
	T292	D063 d22 Z05 RDMT 10	63	22	5	40	0,445	TC067	TC040	T15	ISO
	T293	D063 d22 Z06 RDMT 10	63	22	6	40	0,460	TC067	TC040	T15	
	T294	D080 d27 Z06 RDMT 10	80	27	6	50	1,033	TC067	TC040	T15	
	T294-1	D080 d27 Z07 RDMT 10	80	27	7	50	1,048	TC067	TC040	T15	
	T295	D100 d32 Z07 RDMT 10	100	32	7	50	1,463	TC067	TC040	T15	
	T295-1	D100 d32 Z08 RDMT 10	100	32	8	50	1,478	TC067	TC040	T15	

RDMT 12T3	Order Code	Product Code	Dimensions (mm)								
			D	d	Z	H					
	T280	D040 d16 Z03 RDMT 12	40	16	3	40	0,235	TC067	TC040	T15	
	T281	D040 d16 Z04 RDMT 12	40	16	4	40	0,236	TC067	TC040	T15	
	T282	D050 d22 Z04 RDMT 12	50	22	4	40	0,311	TC067	TC040	T15	
	T283	D050 d22 Z05 RDMT 12	50	22	5	40	0,309	TC067	TC040	T15	RDMT 12T3
	T284	D063 d22 Z05 RDMT 12	63	22	5	40	0,468	TC067	TC040	T15	ISO
	T285	D063 d22 Z06 RDMT 12	63	22	6	40	0,500	TC067	TC040	T15	
	T286	D080 d27 Z06 RDMT 12	80	27	6	50	0,925	TC067	TC040	T15	
	T286-1	D080 d27 Z07 RDMT 12	80	27	7	50	0,950	TC067	TC040	T15	
	T287	D100 d32 Z07 RDMT 12	100	32	7	50	1,402	TC067	TC040	T15	
	T287-1	D100 d32 Z08 RDMT 12	100	32	8	50	1,435	TC067	TC040	T15	

RDMT 1604	Order Code	Product Code	Dimensions (mm)									
			D	d	Z	H						
	T270	D050 d22 Z04 RDMT 16	50	22	4	50	0,350	TC074	BK035	TC080	T15	
	T271	D052 d22 Z04 RDMT 16	52	22	4	50	0,350	TC074	BK035	TC080	T15	RDMT 1604
	T273	D063 d22 Z05 RDMT 16	63	22	5	45	0,512	TC074	BK035	TC080	T15	ISO
	T272	D066 d27 Z05 RDMT 16	66	27	5	50	0,495	TC074	BK035	TC080	T15	
	T274	D080 d27 Z06 RDMT 16	80	27	6	50	0,890	TC074	BK035	TC080	T15	
	T275	D100 d32 Z07 RDMT 16	100	32	7	52	1,370	TC074	BK035	TC080	T15	

With Shim - Mit U-Platte

TPKN 1603-2204	Order Code	Product Code	Dimensions (mm)										
			D	d	Z	H	E						
	T100	D080 d32 Z05 TPKN 16 A	80	32	5	52	--	0,961	TC052	4 Allen	TA010	TC034 M3	TPKN 1603
	T102	D100 d32 Z06 TPKN 16 A	100	32	6	52	--	1,518	TC052	4 Allen	TA010	TC034 M3	ISO
	T104	D080 d32 Z04 TPKN 22 A	80	32	4	52	--	0,810	TC054	5 Allen	TA012	TC038	
	T106	D100 d32 Z05 TPKN 22 A	100	32	5	52	--	1,444	TC054	5 Allen	TA012	TC038	TPKN 2204
	T108	D125 d40 Z06 TPKN 22 A	125	40	6	62	--	3,164	TC054	5 Allen	TA012	TC038	ISO
	T110	D160 d40 Z07 TPKN 22 A	160	40	7	62	66,7	4,220	TC054	5 Allen	TA012	TC038	
	T112	D200 d60 Z08 TPKN 22 A	200	60	8	62	101,6	5,412	TC054	5 Allen	TA012	TC038	
	T113	D250 d60 Z09 TPKN 22 A	250	60	9	62	101,6	8,166	TC054	5 Allen	TA012	TC038	

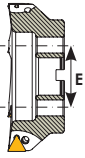
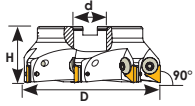
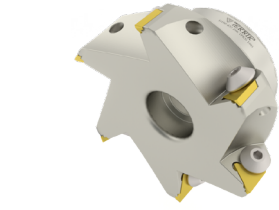
**TPKN 1603-2204**

Order Code	Product Code	Dimensions (mm)									
		D	d	Z	H	E					
T114	D042 d16 Z03 TPKN 16	42	16	3	44	--	0,280	TC052	4 Allen		
T116	D050 d22 Z03 TPKN 16	50	22	3	44	--	0,340	TC052	4 Allen	TPKN 1603	
T118	D063 d22 Z03 TPKN 16	63	22	3	44	--	0,463	TC052	4 Allen	ISO	
T120	D063 d22 Z04 TPKN 16	63	22	4	44	--	0,481	TC052	4 Allen		
T122	D080 d32 Z05 TPKN 16	80	32	5	52	--	0,954	TC052	4 Allen		
T124	D100 d32 Z06 TPKN 16	100	32	6	52	--	1,542	TC052	4 Allen		
T126	D063 d22 Z03 TPKN 22	63	22	3	50	--	0,532	TC054	5 Allen		
T128	D080 d32 Z04 TPKN 22	80	32	4	52	--	0,795	TC054	5 Allen	TPKN 2204	
T130	D100 d32 Z05 TPKN 22	100	32	5	52	--	1,398	TC054	5 Allen	ISO	
T132	D125 d40 Z06 TPKN 22	125	40	6	62	--	3,153	TC054	5 Allen		
T134	D160 d40 Z07 TPKN 22	160	40	7	62	66,7	4,150	TC054	5 Allen		
T136	D200 d60 Z08 TPKN 22	200	60	8	62	101,6	5,458	TC054	5 Allen		
T138	D250 d60 Z09 TPKN 22	250	60	9	62	101,6	8,235	TC054	5 Allen		

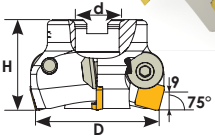
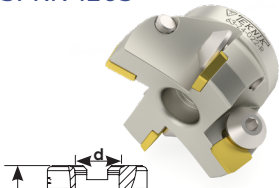
**SPKN 1203**

Order Code	Product Code	Dimensions (mm)						
		ØD	ød	Z	H			
T148	D050 d22 Z03 SPKN 12	50	22	3	45	TC054	5 Allen	SPKN 1203
T150	D063 d22 Z04 SPKN 12	63	22	4	45	TC054	5 Allen	ISO

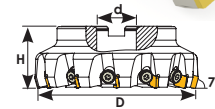
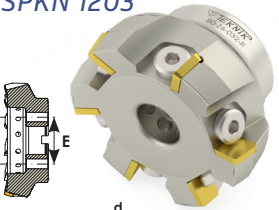
**SPKN 1203**

Order Code	Product Code	Dimensions (mm)									
		D	d	Z	H	E					
T152	D080 d27 Z06 SPKN 12	80	27	6	55	---	1,260	TC056	5 Allen		
T154	D100 d32 Z08 SPKN 12	100	32	8	55	---	1,698	TC056	5 Allen	SPKN 1203	
T156	D125 d40 Z10 SPKN 12	125	40	10	62	---	3,400	TC056	5 Allen	ISO	
T158	D160 d40 Z12 SPKN 12	160	40	12	62	66,7	5,012	TC056	5 Allen		
T160	D200 d60 Z12 SPKN 12	200	60	12	62	101,6	6,542	TC056	5 Allen		
T162	D300 d60 Z20 SPKN 12	300	60	20	65	101,6	15,11	TC056	5 Allen		

## End Mill



[www.teknikcuttingtools.com](http://www.teknikcuttingtools.com)



Kalite için TEKNIK çözüm

Technical solution for quality

20-35

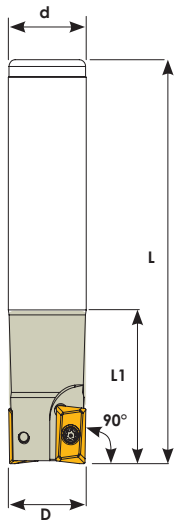
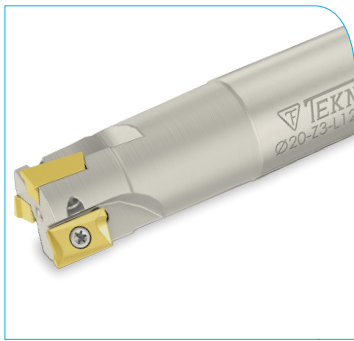

**APXT 1003**

Order Code	Product Code	Dimensions (mm)									
		D	Z	L	d	L1					
S136	D12 d12 Z01 L100 APXT 10	12	1	100	12	27	0,097	TC060	T8		
S138	D14 d14 Z01 L100 APXT 10	14	1	100	14	30	0,126	TC060	T8		
S140	D16 d16 Z02 L100 APXT 10	16	2	100	16	30	0,156	TC060	T8		
S142	D18 d16 Z02 L100 APXT 10	18	2	100	16	30	0,162	TC060	T8		
S144	D20 d20 Z03 L100 APXT 10	20	3	100	20	30	0,231	TC060	T8		
S146	D22 d20 Z03 L100 APXT 10	22	3	100	20	30	0,243	TC060	T8		
S148	D25 d25 Z03 L100 APXT 10	25	3	100	25	35	0,365	TC060	T8		
S150	D30 d25 Z04 L100 APXT 10	30	4	100	25	40	0,400	TC060	T8		
S152	D32 d25 Z04 L100 APXT 10	32	4	100	25	35	0,415	TC060	T8		
S154	D35 d25 Z04 L100 APXT 10	35	4	100	25	30	0,452	TC060	T8		
S156	D40 d25 Z05 L100 APXT 10	40	5	100	25	30	0,477	TC060	T8		
S158	D12 d12 Z01 L120 APXT 10	12	1	120	12	27	0,112	TC060	T8		
S160	D14 d14 Z01 L120 APXT 10	14	1	120	14	30	0,150	TC060	T8		
S162	D16 d16 Z02 L120 APXT 10	16	2	120	16	40	0,185	TC060	T8	APXT 1003	
S164	D18 d16 Z02 L120 APXT 10	18	2	120	16	45	0,190	TC060	T8	KRLY.	
S166	D20 d20 Z03 L120 APXT 10	20	3	120	20	40	0,278	TC060	T8		
S168	D22 d20 Z03 L120 APXT 10	22	3	120	20	40	0,290	TC060	T8		
S169	D25 d25 Z03 L120 APXT 10	25	3	120	25	40	0,452	TC060	T8		
S170	D30 d25 Z04 L120 APXT 10	30	4	120	25	40	0,487	TC060	T8		
S171-1	D32 d25 Z04 L120 APXT 10	32	4	120	25	40	0,511	TC060	T8		
S171	D35 d25 Z04 L120 APXT 10	35	4	120	25	40	0,532	TC060	T8		
S172	D40 d25 Z05 L120 APXT 10	40	5	120	25	40	0,606	TC060	T8		
S173	D16 d16 Z02 L150 APXT 10	16	2	150	16	50	0,230	TC060	T8		
S174	D18 d16 Z02 L150 APXT 10	18	2	150	16	50	0,246	TC060	T8		
S176	D20 d20 Z03 L150 APXT 10	20	3	150	20	60	0,345	TC060	T8		
S178	D22 d20 Z03 L150 APXT 10	22	3	150	20	60	0,360	TC060	T8		
S180	D25 d25 Z03 L150 APXT 10	25	3	150	25	60	0,563	TC060	T8		
S180-1	D30 d25 Z04 L150 APXT 10	30	4	150	25	60	0,610	TC060	T8		
S181	D32 d32 Z04 L150 APXT 10	32	4	150	32	45	0,916	TC060	T8		
S182	D16 d16 Z02 L200 APXT 10	16	2	200	16	60	0,480	TC060	T8		
S184	D18 d16 Z02 L200 APXT 10	18	2	200	16	60	0,350	TC060	T8		
S186	D20 d20 Z03 L200 APXT 10	20	3	200	20	70	0,500	TC060	T8		
S187	D22 d20 Z03 L200 APXT 10	22	3	200	20	70	0,513	TC060	T8		
S188	D25 d25 Z03 L200 APXT 10	25	3	200	25	60	0,771	TC060	T8		
S188-1	D30 d25 Z04 L200 APXT 10	30	4	200	25	50	0,845	TC060	T8		
S189	D32 d32 Z04 L200 APXT 10	32	4	200	32	60	1,253	TC060	T8		
S190	D16 d16 Z02 L250 APXT 10	16	2	250	16	70	0,415	TC060	T8		
S192	D20 d20 Z03 L250 APXT 10	20	3	250	20	70	0,623	TC060	T8		
S194	D25 d25 Z03 L250 APXT 10	25	3	250	25	70	0,953	TC060	T8		

Compatible with / Kompatibel für (KRLY)

## AP-- 1604

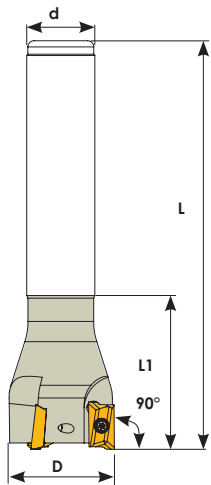

Order Code	Product Code	Dimensions (mm)						TC074	T15	AP-- 1604
		D	Z	L	d	L1	kg			
S256	D25 d25 Z02 L120 AP--16	25	2	120	25	45	0,430	TC074	T15	
S258	D30 d25 Z03 L120 AP--16	30	3	120	25	45	0,460	TC074	T15	
S260	D32 d25 Z03 L120 AP--16	32	3	120	25	45	0,469	TC074	T15	
S262	D35 d25 Z03 L120 AP--16	35	3	120	25	45	0,498	TC074	T15	
S264	D40 d25 Z04 L120 AP--16	40	4	120	25	45	0,547	TC074	T15	
S266	D25 d25 Z02 L150 AP--16	25	2	150	25	55	0,544	TC074	T15	
S268	D30 d25 Z03 L150 AP--16	30	3	150	25	55	0,575	TC074	T15	
S270	D32 d32 Z03 L150 AP--16	32	3	150	32	55	0,876	TC074	T15	AP-- 1604
S272	D35 d32 Z03 L150 AP--16	35	3	150	32	55	0,915	TC074	T15	KRLY.
S274	D40 d32 Z04 L150 AP--16	40	4	150	32	55	0,960	TC074	T15	
S276	D25 d25 Z02 L200 AP--16	25	2	200	25	65	0,750	TC074	T15	
S278	D30 d25 Z03 L200 AP--16	30	3	200	25	55	0,783	TC074	T15	
S280	D32 d32 Z03 L200 AP--16	32	3	200	32	55	1,218	TC074	T15	
S282	D35 d32 Z03 L200 AP--16	35	3	200	32	55	1,245	TC074	T15	
S283	D40 d32 Z04 L200 AP--16	40	4	200	32	55	1,296	TC074	T15	
S432	D25 d25 Z02 L250 AP--16	25	2	250	25	70	0,939	TC074	T15	
S434	D30 d25 Z03 L250 AP--16	30	3	250	25	55	1,028	TC074	T15	
S436	D32 d32 Z03 L250 AP--16	32	3	250	32	60	1,520	TC074	T15	
S438	D35 d32 Z03 L250 AP--16	35	3	250	32	65	1,567	TC074	T15	
S440	D40 d32 Z04 L250 AP--16	40	4	250	32	60	1,612	TC074	T15	
S442	D25 d25 Z02 L300 AP--16	25	2	300	25	70	1,127	TC074	T15	
S444	D30 d25 Z03 L300 AP--16	30	3	300	25	60	1,168	TC074	T15	
S446	D32 d32 Z03 L300 AP--16	32	3	300	32	70	1,827	TC074	T15	
S448	D35 d32 Z03 L300 AP--16	35	3	300	32	65	1,879	TC074	T15	
S450	D40 d32 Z04 L300 AP--16	40	4	300	32	70	1,922	TC074	T15	
S453	D32 d32 Z03 L350 AP--16	32	3	350	32	80	2,274	TC074	T15	
S454	D35 d32 Z03 L350 AP--16	35	3	350	32	65	2,332	TC074	T15	
S456	D40 d32 Z04 L350 AP--16	40	4	350	32	55	2,375	TC074	T15	

Compatible with / Kompatible für (KRLY)

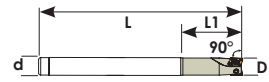
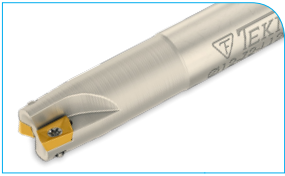
**APMT 0602**

Order Code	Product Code	Dimensions (mm)								
		D	Z	L	d	L1				
S003	D10 d10 Z02 L080 APMT 06	10	2	80	10	20	0,041	TC057-1	T6	
S027	D10 d10 Z02 L100 APMT 06	10	2	100	10	30	0,051	TC057-1	T6	
S009	D10 d10 Z02 L120 APMT 06	10	2	120	10	30	0,085	TC057-1	T6	
S004	D12 d12 Z03 L080 APMT 06	12	3	80	12	25	0,060	TC057-1	T6	APMT 0602
S028	D12 d12 Z03 L100 APMT 06	12	3	100	12	25	0,075	TC057-1	T6	KRLY.
S011	D12 d12 Z02 L120 APMT 06	12	2	120	12	30	0,120	TC057-1	T6	
S005	D16 d16 Z04 L090 APMT 06	16	4	90	16	25	0,120	TC057-1	T6	
S029	D16 d16 Z04 L120 APMT 06	16	4	120	16	25	0,164	TC057-1	T6	
S006	D20 d20 Z05 L110 APMT 06	20	5	110	20	30	0,240	TC057-1	T6	
S030	D20 d20 Z05 L120 APMT 06	20	5	120	20	30	0,263	TC057-1	T6	
S007	D25 d25 Z07 L120 APMT 06	25	7	120	25	30	0,411	TC057-1	T6	
S008	D32 d32 Z08 L120 APMT 06	32	8	120	32	35	0,686	TC057-1	T6	

Compatible with / Kompatible für (KRLY)

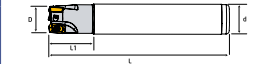
**APMT 0903**

Order Code	Product Code	Dimensions (mm)								
		D	Z	L	d	L1				
S047	D16 d16 Z02 L120 APMT 09	16	2	120	16	30	0,158	TC060	T8	
S048	D20 d20 Z03 L120 APMT 09	20	3	120	20	30	0,261	TC060	T8	APMT 0903
S049	D25 d25 Z04 L130 APMT 09	25	4	130	25	30	0,438	TC060	T8	KRLY
S050	D32 d32 Z05 L130 APMT 09	32	5	130	32	30	0,732	TC060	T8	

Compatible with / Kompatible für (KRLY)

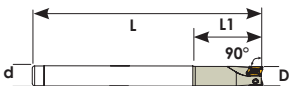
**APMT 11T3**

Order Code	Product Code	Dimensions (mm)								
		D	Z	L	d	L1				
S222	D10 d10 Z01 L085 APMT 11	10	1	85	10	20	0,059	TC060	T8	
S224	D12 d16 Z01 L085 APMT 11	12	1	85	16	25	0,126	TC060	T8	
S226	D14 d16 Z01 L090 APMT 11	14	1	90	16	25	0,139	TC060	T8	
S228	D16 d16 Z02 L090 APMT 11	16	2	90	16	25	0,138	TC060	T8	
S230	D16 d16 Z02 L180 APMT 11	16	2	180	16	30	0,280	TC060	T8	APMT 11T3
S232	D20 d20 Z02 L100 APMT 11	20	2	100	20	30	0,243	TC060	T8	KRLY.
S234	D20 d20 Z02 L210 APMT 11	20	2	210	20	30	0,523	TC060	T8	
S236	D25 d25 Z03 L115 APMT 11	25	3	115	25	35	0,423	TC060	T8	
S238	D25 d25 Z03 L180 APMT 11	25	3	180	25	40	0,749	TC060	T8	
S240	D32 d32 Z04 L125 APMT 11	32	4	125	32	40	0,764	TC061	T8	
S242	D32 d32 Z04 L180 APMT 11	32	4	180	32	50	1,123	TC061	T8	

Compatible with / Kompatible für (KRLY)

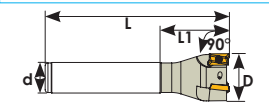
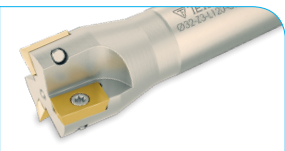
**APMT 1604**

Order Code	Product Code	Dimensions (mm)								
		D	Z	L	d	L1				
S244	D25 d25 Z02 L120 APMT 16	25	2	120	25	45	0,430	TC074	T15	
S245	D25 d25 Z02 L150 APMT 16	25	2	150	25	55	0,610	TC074	T15	APMT 1604
S247	D32 d25 Z03 L120 APMT 16	32	3	120	25	45	0,495	TC074	T15	KRLY.
S248	D32 d32 Z03 L150 APMT 16	32	3	150	32	55	0,874	TC074	T15	
S250	D40 d25 Z04 L120 APMT 16	40	4	120	25	45	0,544	TC074	T15	
S251	D40 d32 Z04 L150 APMT 16	40	4	150	32	55	1,294	TC074	T15	

Compatible with / Kompatible für (KRLY)

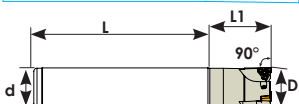
**XNKT 0604**

Order Code	Product Code	Dimensions (mm)								
		D	Z	L	d	L1				
S834	D20 d20 Z02 L150 XNKT 06	20	2	150	20	40	0,365	TC065-1	T8	
S836	D21 d20 Z02 L150 XNKT 06	21	2	150	20	40	0,372	TC065-1	T8	XNKT 0604
S838	D25 d25 Z03 L150 XNKT 06	25	3	150	25	40	0,572	TC065-1	T8	KRLY.
S840	D26 d25 Z03 L150 XNKT 06	26	3	150	25	40	0,572	TC065-1	T8	
S841	D32 d32 Z04 L150 XNKT 06	32	4	150	32	40	0,941	TC065-1	T8	
S842	D40 d32 Z05 L130 XNKT 06	40	5	130	32	45	0,865	TC065-1	T8	

Compatible with / Kompatible für (KRLY)

XNKT 0805	Order Code	Product Code	Dimensions (mm)						TC072	T15	
			D	Z	L	d	L1	kg			
	S843	D32 d32 Z03 L125 XNKT 08	32	3	125	32	37	0,817	TC072	T15	XNKT 0805
	S844	D40 d32 Z04 L130 XNKT 08	40	4	130	32	40	0,986	TC072	T15	KRLY
Compatible with / Kompatible für (KRLY)											

LNMX 1006	Order Code	Product Code	Dimensions (mm)						TC065	T8	
			D	Z	L	d	L1	kg			
	LN096	D16 d16 Z01 L090 LNMX 10	16	1	90	16	25	0,140	TC065	T8	
	LN097	D22 d20 Z02 L100 LNMX 10	22	2	100	20	-	0,263	TC065	T8	LNMX 1006
	LN098	D24 d25 Z03 L100 LNMX 10	24	3	100	25	15	0,389	TC065	T8	KRLY.
	LN099	D20 d20 Z02 L120 LNMX 10	20	2	120	20	25	0,292	TC065	T8	
	LN100	D20 d20 Z03 L120 LNMX 10	20	3	120	20	25	0,285	TC065	T8	
	LN102	D25 d25 Z03 L120 LNMX 10	25	3	120	25	40	0,453	TC065	T8	
	LN103	D32 d32 Z04 L125 LNMX 10	32	4	125	32	40	0,706	TC065	T8	
	LN104	D40 d32 Z05 L130 LNMX 10	40	5	130	32	42	0,857	TC065	T8	
Compatible with / Kompatible für (KRLY)											

LNMX 1510	Order Code	Product Code	Dimensions (mm)						TC076	T15	
			D	Z	L	d	L1	kg			
	S361	D32 d32 Z02 L150 LNMX 15	32	2	150	32	50	0,885	TC076	T15	LNMX 1510
	S362	D40 d32 Z03 L150 LNMX 15	40	3	150	32	50	0,966	TC076	T15	KRLY.
Compatible with / Kompatible für (KRLY)											

WNGX 0403	Order Code	Product Code	Dimensions (mm)						TC060	T8	
			D	Z	L	d	L1	kg			
	S944	D20 d20 Z03 L110 WNGX 04	20	3	110	20	35	0,246	TC060	T8	WNGX 0403
	S945	D25 d25 Z04 L110 WNGX 04	25	4	110	25	35	0,380	TC060	T8	KRLY
	S946	D32 d32 Z05 L110 WNGX 04	32	5	110	32	35	0,642	TC060	T8	
Compatible with / Kompatible für (KRLY)											

WNGX 0806	Order Code	Product Code	Dimensions (mm)						TC083	T20	
			D	Z	L	d	L1	kg			
	S949	D40 d32 Z03 L120 WNGX 08	40	3	120	32	40	0,784	TC083	T20	WNGX 0806 KRLY
Compatible with / Kompatible für (KRLY)											

LNMX 0603	Order Code	Product Code	Dimensions (mm)						TC065	T8	
			D	Z	L	d	L1	kg			
	S284	D16 d16 Z02 L110 LNMX 06	16	2	110	16	30	0,172	TC065	T8	
	S285	D20 d20 Z03 L130 LNMX 06	20	3	130	20	50	0,325	TC065	T8	LNMX 0603
	S286	D25 d25 Z04 L140 LNMX 06	25	4	140	25	60	0,552	TC065	T8	KRLY
	S287	D32 d32 Z05 L150 LNMX 06	32	5	150	32	70	1,516	TC065	T8	
Compatible with / Kompatible für (KRLY)											

WNMX 0603	Order Code	Product Code	Dimensions (mm)						TC061	T8	
			D	Z	L	d	L1	kg			
	S898	D16 d16 Z02 L150 WNMX 06	16	2	150	16	40	0,241	TC061	T8	
	S899	D20 d20 Z02 L150 WNMX 06	20	2	150	20	40	0,378	TC061	T8	WNMX 0603
	S903	D17 d16 Z02 L150 WNMX 06	17	2	150	16	40	0,240	TC061	T8	KRLY.
	S904	D21 d20 Z02 L150 WNMX 06	21	2	150	20	40	0,379	TC061	T8	
	S905	D25 d25 Z03 L150 WNMX 06	25	3	150	25	60	0,578	TC061	T8	
	S906	D26 d25 Z04 L150 WNMX 06	26	4	150	25	60	0,582	TC061	T8	
Compatible with / Kompatible für (KRLY)											

### WNMX 09T3

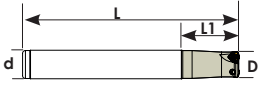

Order Code	Product Code	Dimensions (mm)						TC	S	T	K
		D	Z	L	d	L1	kg				
S802	D25 d25 Z02 L150 WNMX 09	25	2	150	25	60	0,563	TC065	T8		
S803	D26 d25 Z02 L140 WNMX 09	26	2	140	25	60	0,477	TC065	T8		
S804	D30 d25 Z03 L150 WNMX 09	30	3	150	25	60	0,590	TC065	T8	WNMX 09T3	
S805	D32 d32 Z03 L150 WNMX 09	32	3	150	32	70	0,841	TC065	T8	KRLY.	
S806	D33 d32 Z03 L150 WNMX 09	33	3	150	32	70	0,854	TC065	T8		
S807	D40 d32 Z04 L150 WNMX 09	40	4	150	32	60	0,974	TC065	T8		

Compatible with / Kompatible für (KRLY)

### XEKT 1904



Order Code	Product Code	Dimensions (mm)						TC	S	T	K
		D	Z	L	d	L1	kg				
S383	D20 d20 Z01 L130 XEKT 19	20	1	130	20	61	0,251	TC073	T15		
S384	D20 d20 Z01 L200 XEKT 19	20	1	200	20	61	0,412	TC073	T15		
S385	D25 d25 Z02 L140 XEKT 19	25	2	140	25	61	0,415	TC073	T15	XEKT 1904	
S386	D25 d25 Z02 L200 XEKT 19	25	2	200	25	61	0,627	TC073	T15	KRLY	
S387	D32 d32 Z02 L150 XEKT 19	32	2	150	32	71	0,773	TC073	T15		
S388	D32 d32 Z02 L220 XEKT 19	32	2	220	32	81	1,192	TC073	T15		
S389	D40 d40 Z03 L160 XEKT 19	40	3	160	40	61	0,955	TC073	T15		

Compatible with / Kompatible für (KRLY)

### WNMX 1305



Order Code	Product Code	Dimensions (mm)						TC	S	T	K
		D	Z	L	d	L1	kg				
S800	D32 d32 Z02 L120 WNMX 13	32	2	120	32	70	0,933	TC074	T15	WNMX 1305	
S801	D40 d32 Z03 L150 WNMX 13	40	3	150	32	50	1,069	TC074	T15	KRLY	

Compatible with / Kompatible für (KRLY)

### 75° APXT 1003

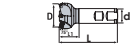
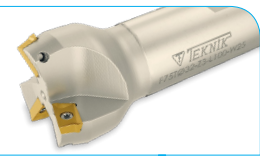

Order Code	Product Code	Dimensions (mm)						TC	S	T	K
		D	Z	L	d	L1	kg				
S344	D32 d25 Z03 L100 APXT 10	32	3	100	25	35	0,413	TC060	T8	APXT	
S346	D40 d25 Z04 L100 APXT 10	40	4	100	25	35	0,494	TC060	T8	1003	
S348	D45 d25 Z04 L100 APXT 10	45	4	100	25	35	0,535	TC060	T8	KRLY.	
S350	D50 d25 Z05 L100 APXT 10	50	5	100	25	35	0,583	TC060	T8		

Compatible with / Kompatible für (KRLY)

### RPMW 0803

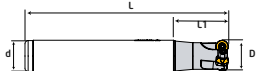
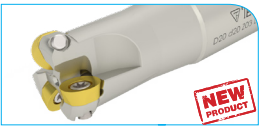

Order Code	Product Code	Dimensions (mm)						TC	S	T	K
		D	Z	L	d	L1	kg				
R310	D16 d16 Z02 L130 RPMW 08	16	2	130	16	35	0,198	TC065-1	T8		
R311	D18 d16 Z02 L150 RPMW 08	18	2	150	16	35	0,240	TC065-1	T8	RPMW 0803	
R312	D20 d20 Z03 L130 RPMW 08	20	3	130	20	35	0,316	TC065-1	T8	KRLY	
R313	D25 d25 Z04 L150 RPMW 08	25	4	150	25	35	0,591	TC065-1	T8		

Compatible with / Kompatible für (KRLY)

### RPMW 10T3

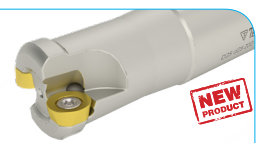

Order Code	Product Code	Dimensions (mm)						TC	S	T	K
		D	Z	L	d	L1	kg				
R316	D20 d20 Z02 L120 RPMW 10	20	2	120	20	40	0,282	TC071	T15		
R317	D25 d25 Z02 L120 RPMW 10	25	2	120	25	40	0,447	TC067	T15	RPMW 10T3	
R318	D25 d25 Z02 L160 RPMW 10	25	2	160	25	60	0,617	TC067	T15	KRLY	
R319	D32 d32 Z04 L125 RPMW 10	32	4	125	32	40	0,792	TC067	T15		
R320	D32 d25 Z04 L200 RPMW 10	32	4	200	25	60	0,891	TC067	T15		
R321	D40 d32 Z04 L150 RPMW 10	40	4	150	32	35	1,071	TC067	T15		

Compatible with / Kompatible für (KRLY)

### RPMW 1204

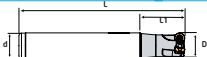
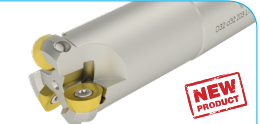

Order Code	Product Code	Dimensions (mm)						TC	S	T	K
		D	Z	L	d	L1	kg				
R325	D25 d25 Z02 L160 RPMW 12	25	2	160	25	60	0,607	TC073	T15		
R326	D32 d32 Z03 L160 RPMW 12	32	3	160	32	60	1,017	TC073	T15	RPMW 1204	
R327	D40 d32 Z04 L150 RPMW 12	40	4	150	32	35	1,056	TC073	T15	KRLY	

Compatible with / Kompatible für (KRLY)

Round Milling Cutter

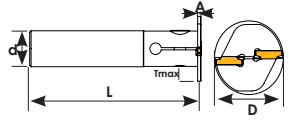

Order Code	Product Code	Dimensions (mm)							TC	Screw	Image	Material
		D	A	Z	L	d	Tmax	kg				
TKÇ300	D50 A03 Z02 L-120	50	3	2	120	25	12,75	0,498	TC163	6 Allen	MGM 3C	
TKÇ301	D63 A03 Z02 L-120	63	3	2	120	25	19,25	0,543	TC163	6 Allen	KRLY.	
TKÇ302	D80 A03 Z02 L-120	80	3	2	120	32	24,25	0,841	TC163	6 Allen		
TKÇ303	D50 A04 Z02 L-120	50	4	2	120	25	12,75	0,536	TC163	6 Allen	MGM 4C	
TKÇ304	D63 A04 Z02 L-120	63	4	2	120	25	19,25	0,556	TC163	6 Allen	KRLY.	
TKÇ305	D80 A04 Z02 L-120	80	4	2	120	32	24,25	0,860	TC163	6 Allen		
TKÇ306	D55 A05 Z02 L-120	55	5	2	120	25	15,25	0,513	TC163	6 Allen	MGM 5C	
TKÇ307	D63 A05 Z02 L-120	63	5	2	120	25	19,25	0,529	TC163	6 Allen	KRLY.	
TKÇ308	D80 A05 Z02 L-120	80	5	2	120	32	24,25	0,860	TC163	6 Allen		

Compatible with / Kompatible für (KRLY)

TWX 16R

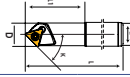

Order Code	Product Code	Dimensions (mm)							TC	Screw	Image	Material
		K	D	Z	L	d	L1	kg				
S352	D21 d20 Z01 L110 TWX 16	45°	21	1	110	20	50	0,260	TC072	T15	TWX 16R-KRLY	

Compatible with / Kompatible für (KRLY)

APKT 1003-1604

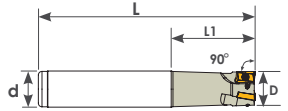

Order Code	Product Code	Dimensions (mm)						TC	Screw	Image	Material
		D	Z	L	d	L1	kg				
S031	D16 d16 Z02 L100 APKT 10	16	2	100	16	30	0,275	TC060	T8		
S032	D20 d20 Z03 L100 APKT 10	20	3	100	20	30	0,342	TC060	T8		
S033	D25 d25 Z03 L100 APKT 10	25	3	100	25	35	0,376	TC063	T8	APKT 1003	
S034	D32 d25 Z04 L100 APKT 10	32	4	100	25	35	0,768	TC063	T8	YG1	
S035	D16 d16 Z02 L150 APKT 10	16	2	150	16	50	0,320	TC060	T8		
S036	D20 d20 Z03 L150 APKT 10	20	3	150	20	60	0,368	TC060	T8		
S037	D25 d25 Z03 L150 APKT 10	25	3	150	25	60	0,541	TC060	T8		
S038	D32 d32 Z04 L150 APKT 10	32	4	150	32	45	0,946	TC063	T8		
S046	D40 d25 Z04 L120 APKT 16	40	4	120	25	45	0,516	TC074	T15	APKT 1604 YG1	

Compatible with / Kompatible für (YG1)

ENMX 0604

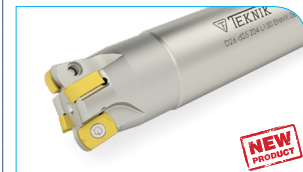

NEW PRODUCT

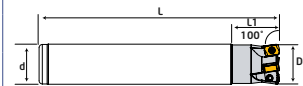

Order Code	Product Code	Dimensions (mm)						TC	Screw	Image	Material
		D	Z	L	d	L1	kg				
S105	D16 d16 Z02 L100 ENMX 06	16	2	100	16	30	0,146	TC063	T8		
S106	D16 d16 Z02 L150 ENMX 06	16	2	150	16	50	0,228	TC063	T8	ENMX 0604	
S107	D17 d16 Z02 L150 ENMX 06	17	2	150	16	20	0,242	TC063	T8	YG1	
S108	D20 d20 Z03 L130 ENMX 06	20	3	130	20	50	0,316	TC063	T8		
S109	D20 d20 Z03 L160 ENMX 06	20	3	160	20	80	0,382	TC063	T8		
S110	D21 d20 Z03 L150 ENMX 06	21	3	150	20	20	0,391	TC063	T8		
S111	D25 d25 Z04 L140 ENMX 06	25	4	140	25	60	0,538	TC063	T8		
S112	D25 d25 Z04 L180 ENMX 06	25	4	180	25	80	0,696	TC063	T8		
S113	D26 d25 Z04 L150 ENMX 06	26	4	150	25	30	0,612	TC063	T8		
S114	D32 d32 Z05 L150 ENMX 06	32	5	150	32	70	0,963	TC063	T8		
S115	D32 d32 Z05 L200 ENMX 06	32	5	200	32	70	0,963	TC063	T8		

Compatible with / Kompatible für (YG1)

ENMX 0905



NEW PRODUCT

Order Code	Product Code	Dimensions (mm)						TC	Screw	Image	Material
		D	Z	L	d	L1	kg				
S934	D25 d25 Z02 L150 ENMX 09	25	2	150	25	70	0,576	TC069	T15		
S935	D32 d32 Z03 L160 ENMX 09	32	3	160	32	70	1,015	TC069	T15	ENMX 0905	
S936	D40 d32 Z05 L180 ENMX 09	40	5	180	32	40	1,308	TC069	T15	YG1	

Compatible with / Kompatible für (YG1)

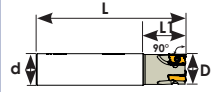
**ANKX 1205**

Order Code	Product Code	Dimensions (mm)									
		D	Z	L	d	L1					
S695	D32 d32 Z03 L120 ANKX 12	32	3	120	32	40	0,700	TC074	T15	ANKX 1205 ISCR.	
<i>Compatible with / Kompatible für (ISCR)</i>											

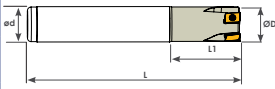
**LNMT 0804**

Order Code	Product Code	Dimensions (mm)									
		D	Z	L	d	L1					
S298	D16 d16 Z02 L120 LNMT 08	16	2	120	16	40	0,206	TC061	T8		
S299	D20 d20 Z03 L120 LNMT 08	20	3	120	20	40	0,313	TC061	T8	LNMT 0804	
S300	D25 d25 Z04 L120 LNMT 08	25	4	120	25	40	0,477	TC061	T8	ISCR.	
S300-1	D32 d32 Z05 L120 LNMT 08	32	5	120	32	40	0,775	TC061	T8		
S301	D16 d16 Z02 L150 LNMT 08	16	2	150	16	40	0,256	TC061	T8		
S302	D20 d20 Z03 L150 LNMT 08	20	3	150	20	40	0,391	TC061	T8		
S303	D25 d25 Z04 L150 LNMT 08	25	4	150	25	40	0,601	TC061	T8		
S303-1	D32 d32 Z05 L150 LNMT 08	32	5	150	32	40	0,978	TC061	T8		
<i>Compatible with / Kompatible für (ISCR)</i>											

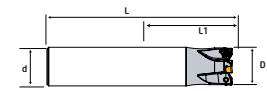
**WNMU 0403**

Order Code	Product Code	Dimensions (mm)									
		D	Z	L	d	L1					
S457	D20 d20 Z03 L120 WNMU 04	20	3	120	20	25	0,290	TC060	T8	WNMU 0403	
S458	D25 d25 Z04 L120 WNMU 04	25	4	120	25	30	0,466	TC060	T8	ISCR	
S459	D32 d32 Z04 L120 WNMU 04	32	4	120	32	35	0,776	TC060	T8		
<i>Compatible with / Kompatible für (ISCR)</i>											

**ADKT 1505**

Order Code	Product Code	Dimensions (mm)									
		D	Z	L	d	L1					
S304	D25 d25 Z02 L120 ADKT 15	25	2	120	25	45	0,434	TC074	T15		
S306	D30 d25 Z03 L120 ADKT 15	30	3	120	25	45	0,466	TC074	T15		
S307	D32 d25 Z03 L120 ADKT 15	32	3	120	25	45	0,477	TC074	T15		
S308	D35 d25 Z03 L120 ADKT 15	35	3	120	25	45	0,500	TC074	T15		
S310	D40 d32 Z04 L120 ADKT 15	40	4	120	32	45	0,759	TC074	T15		
S312	D25 d25 Z02 L150 ADKT 15	25	2	150	25	60	0,550	TC074	T15	ADKT 1505	
S314	D30 d25 Z03 L150 ADKT 15	30	3	150	25	50	0,596	TC074	T15	ISCR.	
S315	D32 d32 Z03 L150 ADKT 15	32	3	150	32	60	0,887	TC074	T15		
S316	D35 d32 Z03 L150 ADKT 15	35	3	150	32	50	0,920	TC074	T15		
S317	D40 d32 Z04 L150 ADKT 15	40	4	150	32	45	1,102	TC074	T15		
S318	D25 d25 Z02 L200 ADKT 15	25	2	200	25	55	0,711	TC074	T15		
S319	D30 d25 Z03 L200 ADKT 15	30	3	200	25	50	0,783	TC074	T15		
S320	D32 d32 Z03 L200 ADKT 15	32	3	200	32	60	1,198	TC074	T15		
S321	D35 d32 Z03 L200 ADKT 15	35	3	200	32	50	1,252	TC074	T15		
S322	D40 d32 Z04 L200 ADKT 15	40	4	200	32	60	1,272	TC074	T15		
<i>Compatible with / Kompatible für (ISCR)</i>											

*Compatible with / Kompatible für (ISCR)*

### AXMT 0602 - APKT 0903

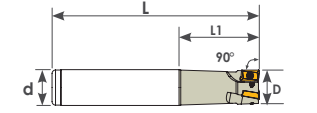
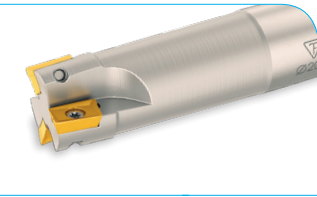

Order Code	Product Code	Dimensions (mm)								
		D	Z	L	d	L1				
S010	D10 d10 Z02 L120 AXMT 06	10	2	120	10	30	0,085	TC057-1	T6	AXMT 0602
S012	D12 d12 Z02 L120 AXMT 06	12	2	120	12	30	0,119	TC057-1	T6	TGTC.
S014	D16 d16 Z02 L120 APKT 09	16	2	120	16	40	0,195	TC060	T8	
S016	D20 d20 Z03 L120 APKT 09	20	3	120	20	45	0,296	TC060	T8	
S018	D25 d25 Z03 L120 APKT 09	25	3	120	25	45	0,447	TC060	T8	
S020	D16 d16 Z02 L150 APKT 09	16	2	150	16	50	0,233	TC060	T8	APKT 0903
S022	D20 d20 Z03 L150 APKT 09	20	3	150	20	60	0,370	TC060	T8	TGTC.
S024	D25 d25 Z03 L150 APKT 09	25	3	150	25	60	0,583	TC060	T8	

Compatible with. / Kompatible für (TGTC)

### APKT 1705

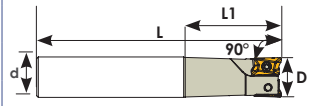
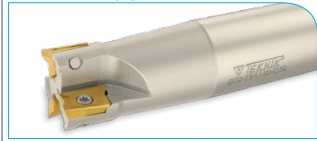

Order Code	Product Code	Dimensions (mm)								
		D	Z	L	d	L1				
S660	D25 d25 Z02 L150 APKT 17	25	2	150	25	60	0,534	TC074	T15	
S660-1	D25 d25 Z02 L200 APKT 17	25	2	200	25	60	0,763	TC074	T15	APKT 1705
S662	D32 d32 Z03 L150 APKT 17	32	3	150	32	60	0,850	TC074	T15	TGTC.
S662-1	D32 d32 Z03 L200 APKT 17	32	3	200	32	60	1,236	TC074	T15	
S664	D40 d32 Z04 L150 APKT 17	40	4	150	32	60	0,850	TC074	T15	

Compatible with. / Kompatible für (TGTC)

### 3PKT 1004

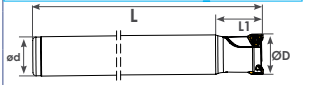

Order Code	Product Code	Dimensions (mm)								
		D	Z	L	d	L1				
S485	D21 d20 Z02 L200 3PKT 10	21	2	200	20	30	1,259	TC093	T8	3PKT 1004
S486	D26 d25 Z02 L200 3PKT 10	26	2	200	25	30	0,773	TC093	T8	TGTC.
S487	D33 d32 Z03 L200 3PKT 10	33	3	200	32	40	0,495	TC093	T8	

Compatible with. / Kompatible für (TGTC)

### 4NKT 06

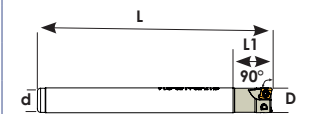

Order Code	Product Code	Dimensions (mm)								
		D	Z	L	d	L1				
S471	D16 d16 Z02 L120 4NKT 06	16	2	120	16	25	0,200	TC064	T8	
S471-1	D16 d16 Z02 L150 4NKT 06	16	2	150	16	25	0,250	TC064	T8	4NKT 06
S472	D17 d16 Z02 L150 4NKT 06	17	2	150	16	22	0,241	TC064	T8	TGTC.
S473	D20 d20 Z03 L120 4NKT 06	20	3	120	20	25	0,306	TC064	T8	
S474	D21 d20 Z03 L200 4NKT 06	21	3	200	20	25	0,524	TC064	T8	
S475	D25 d25 Z04 L120 4NKT 06	25	4	120	25	30	0,474	TC064	T8	
S475-1	D25 d25 Z03 L200 4NKT 06	25	3	200	25	30	0,806	TC064	T8	
S476	D26 d25 Z03 L200 4NKT 06	26	3	200	25	30	0,815	TC064	T8	
S477	D33 d32 Z04 L200 4NKT 06	33	4	200	32	35	1,327	TC064	T8	
S477-1	D33 d32 Z04 L220 4NKT 06	33	4	220	32	35	1,462	TC064	T8	
S477-2	D40 d32 Z05 L200 4NKT 06	40	5	200	32	40	1,395	TC064	T8	

Compatible with. / Kompatible für (TGTC)

### BLMP 0603

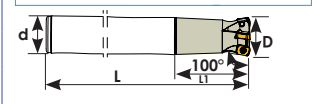

Order Code	Product Code	Dimensions (mm)								
		D	Z	L	d	L1				
S479	D16 d16 Z02 L150 BLMP 06	16	2	150	16	40	0,235	TC064	T8	
S478	D17 d16 Z02 L150 BLMP 06	17	2	150	16	40	0,244	TC064	T8	BLMP 0603
S481	D20 d20 Z03 L150 BLMP 06	20	3	150	20	40	0,335	TC064	T8	TGTC.
S483	D25 d25 Z04 L150 BLMP 06	25	4	150	25	30	0,280	TC064	T8	
S480	D21 d25 Z03 L200 BLMP 06	21	3	200	25	40	0,520	TC064	T8	
S482	D26 d25 Z04 L200 BLMP 06	26	4	200	25	40	0,771	TC064	T8	

Compatible with. / Kompatible für (TGTC)

**SPMG 0502 - 0602-07T3 0904**

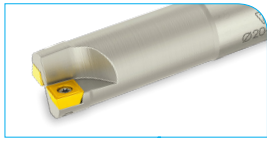

Order Code	Product Code	Dimensions (mm)						TC	T	Icon
		D	Z	L	d	LI	kg			
S810	D013 d14 Z02 L120 SPMG 05	13	2	120	14	40	0,147	TC058	T6	SPMG 0502
S812	D13,5 d14 Z02 L120 SPMG 05	13,5	2	120	14	40	0,149	TC058	T6	TGTC
S814	D014 d14 Z02 L120 SPMG 06	14	2	120	14	40	0,148	TC059	T7	SPMG 0602
S818	D015 d16 Z02 L120 SPMG 06	15	2	120	16	40	0,186	TC059	T7	TGTC
S822	D016 d16 Z02 L120 SPMG 06	16	2	120	16	40	0,194	TC059	T7	
S824	D020 d20 Z02 L150 SPMG 07	20	2	150	20	50	0,198	TC063	T8	SPMG 07T3
S826	D20,5 d20 Z02 L120 SPMG 07	20,5	2	120	20	50	0,290	TC063	T8	TGTC
S828	D025 d25 Z02 L150 SPMG 09	25	2	150	25	50	0,567	TC067	T15	SPMG 0904
S830	D032 d32 Z03 L150 SPMG 09	32	3	150	32	40	0,908	TC067	T15	TGTC

Compatible with / Kompatibel für (TGTC)

**RDMW 0501**

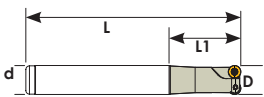

Order Code	Product Code	Dimensions (mm)						TC	T	Icon
		D	Z	L	d	LI	kg			
R080	D08 d10 Z01 L080 RDMW 05	8	1	80	10	27	0,053	TC058	T6	
R082	D10 d12 Z02 L080 RDMW 05	10	2	80	12	34	0,076	TC058	T6	RDMW 0501
R083	D10 d12 Z02 L100 RDMW 05	10	2	100	12	40	0,085	TC058	T6	TGTC
R084	D10 d12 Z02 L120 RDMW 05	10	2	120	12	45	0,111	TC058	T6	
R086	D12 d12 Z02 L100 RDMW 05	12	2	100	12	40	0,099	TC058	T6	
R088	D12 d12 Z02 L120 RDMW 05	12	2	120	12	45	0,118	TC058	T6	

Compatible with / Kompatibel für (TGTC)

**RDMW 0702**

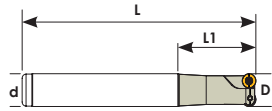
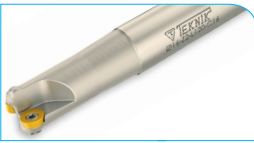

Order Code	Product Code	Dimensions (mm)						TC	T	Icon
		D	Z	L	d	LI	kg			
R136	D15 d16 Z02 L120 RDMW 07	15	2	120	16	40	0,187	TC060	T6	
R138	D16 d16 Z02 L120 RDMW 07	16	2	120	16	40	0,148	TC060	T6	RDMW 0702
R142	D20 d20 Z03 L120 RDMW 07	20	3	120	20	45	0,278	TC060	T6	TGTC
R143	D15 d16 Z02 L150 RDMW 07	15	2	150	16	50	0,228	TC060	T6	
R144	D16 d16 Z02 L150 RDMW 07	16	2	150	16	60	0,230	TC060	T6	
R148	D20 d20 Z03 L150 RDMW 07	20	3	150	20	60	0,354	TC060	T6	

Compatible with / Kompatibel für (TGTC)

**LNMU 0303**

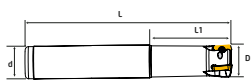
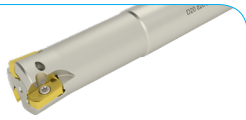

Order Code	Product Code	Dimensions (mm)						TC	T	Icon
		D	Z	L	d	LI	kg			
S671	D16 d16 Z02 L150 LNMU 03	16	2	150	16	50	0,233	TC063	T8	
S672	D17 d16 Z02 L150 LNMU 03	17	2	150	16	40	0,241	TC063	T8	LNMU 0303
S673	D20 d20 Z03 L150 LNMU 03	20	3	150	20	50	0,381	TC063	T8	TNGLY - OKE
S674	D21 d20 Z03 L150 LNMU 03	21	3	150	20	50	0,389	TC063	T8	
S675	D25 d25 Z04 L150 LNMU 03	25	4	150	25	60	0,589	TC063	T8	

Compatible with / Kompatibel für (TNGLY - OKE)

**XNEX 0403**

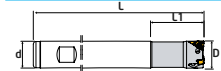
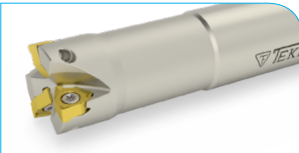

Order Code	Product Code	Dimensions (mm)						TC	T	Icon
		D	Z	L	d	LI	kg			
S194-1	D17 d16 Z02 L150 XNEX 04	17	2	150	16	30	0,225	TC061	T8	
S195	D20 d20 Z03 L150 XNEX 04	20	3	150	20	40	0,344	TC061	T8	XNEX 0403
S196	D21 d20 Z03 L150 XNEX 04	21	3	150	20	40	0,348	TC061	T8	SCO
S198	D26 d25 Z04 L150 XNEX 04	26	4	150	25	40	0,535	TC061	T8	

Compatible withinsert. / Kompatibel für (SCO)

**LOEX 0804**

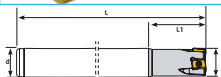

Order Code	Product Code	Dimensions (mm)						TC	T	Icon
		D	Z	L	d	LI	kg			
S295	D20 d20 Z03 L150 LOEX 08	20	3	150	20	40	0,384	TC063	T8	LOEX 0804
S296	D25 d25 Z04 L150 LOEX 08	25	4	150	25	40	0,604	TC063	T8	SCO

Compatible with / Kompatibel für (SCO)

XOMX 0602- 0903-1204

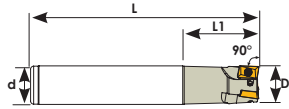
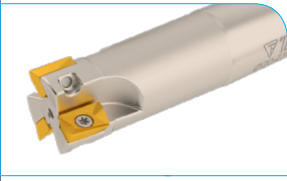

Order Code	Product Code	Dimensions (mm)						TC	T	Material
		D	Z	L	d	L1	kg			
S623	D10 d10 Z02 L120 XOMX 06	10	2	120	10	40	0,086	TC057-1	T6	XOMX 0602
S625	D12 d12 Z02 L120 XOMX 06	12	2	120	12	30	0,119	TC057-1	T6	SCO.
S627	D16 d16 Z02 L120 XOMX 09	16	2	120	16	45	0,197	TC060	T8	
S626	D20 d20 Z03 L120 XOMX 09	20	3	120	20	40	0,297	TC060	T8	XOMX 0903
S629	D16 d16 Z02 L150 XOMX 09	16	2	150	16	45	0,228	TC060	T8	SCO.
S628	D20 d20 Z03 L150 XOMX 09	20	3	150	20	55	0,373	TC060	T8	
S636	D20 d20 Z03 L200 XOMX 09	20	3	200	20	55	0,507	TC060	T8	
S632	D25 d25 Z03 L150 XOMX 09	25	3	150	25	55	0,352	TC060	T8	
S638	D20 d20 Z02 L120 XOMX 12	20	2	120	20	45	0,500	TC069	T10	
S640	D20 d20 Z02 L150 XOMX 12	20	2	150	20	55	0,439	TC069	T10	
S641	D20 d20 Z02 L200 XOMX 12	20	2	200	20	60	0,504	TC069	T10	XOMX 1204
S642	D25 d25 Z03 L120 XOMX 12	25	3	120	25	45	0,443	TC069	T10	SCO.
S643	D25 d25 Z03 L150 XOMX 12	25	3	150	25	55	0,574	TC069	T10	
S644	D25 d25 Z03 L200 XOMX 12	25	3	200	25	60	0,779	TC069	T10	
S645	D25 d25 Z03 L250 XOMX 12	25	3	250	25	70	0,856	TC069	T10	
S647	D32 d32 Z04 L120 XOMX 12	32	4	120	25	45	0,965	TC069	T10	
S648	D32 d32 Z04 L150 XOMX 12	32	4	150	32	55	0,937	TC069	T10	
S650	D40 d32 Z04 L150 XOMX 12	40	4	150	32	45	1,047	TC069	T10	

Compatible with / Kompatible für (SCO)

R390-11T3 -1704-1806

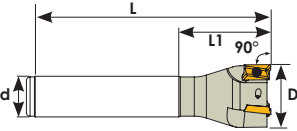

Order Code	Product Code	Dimensions (mm)						TC	T	Material
		D	Z	L	d	L1	kg			
S591	D16 d16 Z02 L120 R390 11	16	2	120	16	40	0,180	TC060	T8	
S592	D20 d20 Z03 L120 R390 11	20	3	120	20	40	0,270	TC063	T8	
S592-1	D25 d25 Z03 L120 R390 11	25	3	120	25	45	0,446	TC063	T8	
S593	D16 d16 Z02 L150 R390 11	16	2	150	16	40	0,229	TC060	T8	R390-11T3
S594	D20 d20 Z03 L150 R390 11	20	3	150	20	50	0,348	TC063	T8	SNDVK.
S594-1	D21 d20 Z03 L150 R390 11	21	3	150	20	50	0,366	TC060	T8	
S595	D25 d25 Z03 L150 R390 11	25	3	150	25	50	0,557	TC063	T8	
S595-1	D26 d25 Z04 L150 R390 11	26	4	150	25	50	0,557	TC063	T8	
S596	D20 d20 Z03 L200 R390 11	20	3	200	20	50	0,480	TC060	T8	
S597	D25 d25 Z03 L200 R390 11	25	3	200	25	50	0,762	TC063	T8	
S598	D25 d25 Z03 L250 R390 11	25	3	250	25	60	0,951	TC063	T8	
S510	D25 d25 Z02 L120 R390 17	25	2	120	25	45	0,425	TC067	T15	
S512	D30 d25 Z03 L120 R390 17	30	3	120	25	45	0,461	TC067	T15	
S514	D32 d25 Z03 L120 R390 17	32	3	120	25	45	0,459	TC067	T15	
S518	D40 d32 Z04 L120 R390 17	40	4	120	32	45	0,782	TC067	T15	
S520	D25 d25 Z02 L150 R390 17	25	2	150	25	55	0,536	TC067	T15	R390-1704
S522	D30 d25 Z03 L150 R390 17	30	3	150	25	55	0,582	TC067	T15	SNDVK.
S524	D32 d32 Z03 L150 R390 17	32	3	150	32	55	0,854	TC067	T15	
S528	D40 d32 Z04 L150 R390 17	40	4	150	32	55	0,936	TC067	T15	
S530	D25 d25 Z02 L200 R390 17	25	2	200	25	60	0,741	TC067	T15	
S532	D30 d25 Z03 L200 R390 17	30	3	200	25	55	0,773	TC067	T15	
S534	D32 d32 Z03 L200 R390 17	32	3	200	32	55	0,781	TC067	T15	
S538	D40 d32 Z04 L200 R390 17	40	4	200	32	55	1,272	TC067	T15	
S603	D25 d25 Z02 L150 R390 18	25	2	150	25	60	0,530	TC074	T15	
S600	D25 d25 Z02 L200 R390 18	25	2	200	25	60	0,756	TC074	T15	R390-1806
S605	D32 d32 Z03 L150 R390 18	32	3	150	32	60	0,850	TC074	T15	SNDVK.
S601	D32 d32 Z03 L200 R390 18	32	3	200	32	60	1,188	TC074	T15	

Compatible with / Kompatible für (SNDVK)

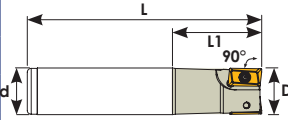
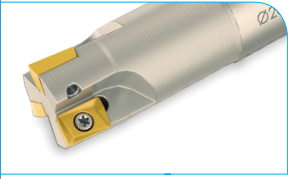
**APKT 0903**

Order Code	Product Code	Dimensions (mm)						TC	T	WLT
		D	Z	L	d	L1	kg			
S204	D16 d16 Z02 L120 APKT 09	16	2	120	16	40	0,185	TC060	T8	
S206	D20 d20 Z03 L120 APKT 09	20	3	120	20	45	0,278	TC063	T8	APKT 0903
S208	D25 d25 Z03 L120 APKT 09	25	3	120	25	45	0,453	TC063	T8	WLTR.
S210	D16 d16 Z02 L150 APKT 09	16	2	150	16	50	0,237	TC060	T8	
S212	D20 d20 Z03 L150 APKT 09	20	3	150	20	45	0,354	TC063	T8	
S214	D25 d25 Z03 L150 APKT 09	25	3	150	25	45	0,590	TC063	T8	
S216	D16 d16 Z02 L200 APKT 09	16	2	200	16	60	0,340	TC060	T8	
S218	D20 d20 Z03 L200 APKT 09	20	3	200	20	60	0,502	TC063	T8	
S220	D25 d25 Z03 L200 APKT 09	25	3	200	25	60	0,765	TC063	T8	

Compatible with/ Kompatible für (WLTR)

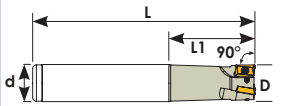
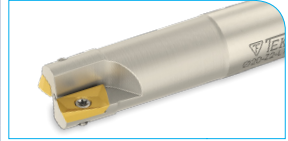
**ADMT 1204**

Order Code	Product Code	Dimensions (mm)						TC	T	WLT
		D	Z	L	d	L1	kg			
S498	D20 d20 Z02 L120 ADMT 12	20	2	120	20	40	0,275	TC065	T8	
S500	D20 d20 Z02 L150 ADMT 12	20	2	150	20	55	0,348	TC065	T8	ADMT 1204
S501	D20 d20 Z02 L200 ADMT 12	20	2	200	20	60	0,498	TC065	T8	WLTR.
S501-1	D25 d25 Z03 L120 ADMT 12	25	3	120	25	40	0,443	TC065	T8	
S502	D25 d25 Z03 L150 ADMT 12	25	3	150	25	60	0,550	TC065	T8	
S503	D30 d25 Z04 L150 ADMT 12	30	4	150	25	60	0,558	TC065	T8	
S504	D32 d32 Z04 L150 ADMT 12	32	4	150	32	50	0,932	TC065	T8	
S506	D40 d32 Z05 L150 ADMT 12	40	5	150	32	50	0,968	TC065	T8	

Compatible with/ Kompatible für (WLTR)

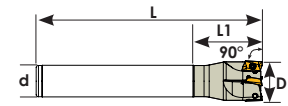
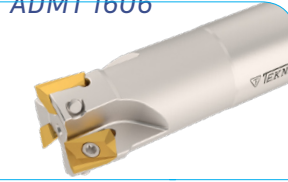
**ADMT 1606**

Order Code	Product Code	Dimensions (mm)						TC	T	WLT
		D	Z	L	d	L1	kg			
S460	D25 d25 Z02 L150 ADMT 16	25	2	150	25	60	0,534	TC079	T15	
S461	D25 d25 Z02 L200 ADMT 16	25	2	200	25	60	0,744	TC079	T15	ADMT 1606
S463	D26 d25 Z02 L150 ADMT 16	26	2	150	25	60	0,545	TC079	T15	WLTR.
S464	D26 d25 Z02 L200 ADMT 16	26	2	200	25	60	0,751	TC079	T15	
S466	D32 d32 Z03 L150 ADMT 16	32	3	150	32	60	0,784	TC079	T15	
S467	D32 d32 Z03 L200 ADMT 16	32	3	200	32	60	1,085	TC079	T15	
S469	D40 d32 Z04 L150 ADMT 16	40	4	150	32	60	0,927	TC079	T15	
S470	D40 d32 Z04 L200 ADMT 16	40	4	200	32	60	1,310	TC079	T15	

Compatible with/ Kompatible für (WLTR)

**LNHU 0904**

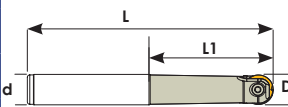

Order Code	Product Code	Dimensions (mm)						TC	T	WLT
		D	Z	L	d	L1	kg			
S328	D25 d25 Z03 L150 LNHU 09	25	3	150	25	40	0,599	TC065-1	T8	LNHU 0904
S329	D32 d32 Z04 L150 LNHU 09	32	4	150	32	40	0,972	TC065-1	T8	WLTR.

Compatible with / Kompatible für (WLTR)

**Indexable Ball Nose End Mill**

Order Code	Product Code	Dimensions (mm)					TC	T	WLT
		D	L	d	L1	kg			
S370	D08 d10 L130 P32-08	8	130	10	35	0,092	TC170 M3	T8	P32 08 WLTR.
S372	D10 d12 L130 P32-10	10	130	12	35	0,118	TC172 M4	T15	P32 10 WLTR.
S374	D12 d12 L150 P32-12	12	150	12	35	0,142	TC174 M5	T20	P32 12 WLTR.
S376	D16 d16 L175 P32-16	16	175	16	46	0,270	TC176 M5	T20	P32 16 WLTR.
S378	D20 d20 L200 P32-20	20	200	20	56	0,505	TC178 M5	T20	P32 20 WLTR.
S380	D25 d25 L200 P32-25	25	200	25	66	0,745	TC181 M6	3 Allen	P32 25 WLTR.
S381	D30 d32 L200 P32-30	30	200	32	66	1,148	TC184 M8	3 Allen	P32 30 WLTR.
S382	D32 d32 L200 P32-32	32	200	32	66	1,150	TC184 M8	4 Allen	P32 32 WLTR.

Compatible with/ Kompatible für (WLTR)

APKT 1003	Order Code	Product Code	Dimensions (mm)					TC060	T8	APKT 1003	
			D	Z	L	d	L1				
	S766	D16 d16 Z02 L085 APKT 10	16	2	85	16	26	0,123	TC060	T8	APKT 1003
	S767	D20 d20 Z03 L090 APKT 10	20	3	90	20	28	0,209	TC060	T8	PLBT
	S768	D25 d20 Z04 L150 APKT 10	25	4	150	20	26	0,388	TC060	T8	
<i>Compatible with /Kompatible für (PLBT)</i>											

ANHX 1004 - 1206	Order Code	Product Code	Dimensions (mm)					TC065	T8	ANHX 1004	
			D	Z	L	d	L1				
	S775	D16 d16 Z02 L090 ANHX 10	16	2	90	16	25	0,140	TC065	T8	
	S776	D20 d20 Z02 L100 ANHX 10	20	2	100	20	30	0,247	TC065	T8	ANHX 1004
	S762	D25 d25 Z03 L115 ANHX 10	25	3	115	25	35	0,432	TC065	T8	PLBT
	S763	D32 d32 Z03 L125 ANHX 10	32	3	125	32	40	0,783	TC065	T8	
	S782	D16 d16 Z02 L160 ANHX 10	16	2	160	16	25	0,036	TC065	T8	
	S783	D20 d20 Z03 L160 ANHX 10	20	3	160	20	30	0,058	TC065	T8	
	S784	D25 d25 Z03 L180 ANHX 10	25	3	180	25	35	0,099	TC065	T8	
	S785	D32 d32 Z04 L150 ANHX 10	32	4	150	32	40	0,136	TC065	T8	
	S764	D25 d25 Z02 L110 ANHX 12	25	2	110	25	35	0,405	TC069	T10	ANHX 1206
	S765	D32 d32 Z03 L150 ANHX 12	32	3	150	32	35	0,922	TC069	T10	PLBT
<i>Compatible with /Kompatible für (PLBT)</i>											

RDMT 1003-12T3	Order Code	Product Code	Dimensions (mm)					TC071	T15	RDMT 1003	
			D	Z	L	d	L1				
	S771	D20 d20 Z02 L160 RDMT 10	20	2	160	20	60	0,359	TC071	T15	RDMT 1003
	S772	D20 d25 Z02 L220 RDMT 10	20	2	220	25	120	0,658	TC071	T15	PLBT
	S773	D25 d25 Z02 L220 RDMT 12	25	2	220	25	120	0,741	TC067	T15	RDMT 12T3
	S774	D25 d32 Z02 L230 RDMT 12	25	2	230	32	130	1,099	TC067	T15	PLBT
<i>Compatible with /Kompatible für (PLBT)</i>											

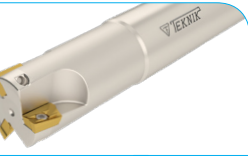
BDMT 11T3	Order Code	Product Code	Dimensions (mm)					TC060	T8	BDMT 11T3	
			D	Z	L	d	L1				
	S565	D16 d16 Z02 L150 BDMT 11	16	2	150	16	45	0,232	TC060	T8	
	S566	D18 d16 Z02 L150 BDMT 11	18	2	150	16	44	0,240	TC060	T8	BDMT 11T3
	S567	D20 d20 Z03 L150 BDMT 11	20	3	150	20	50	0,351	TC060	T8	KYCRA.
	S569	D25 d25 Z03 L150 BDMT 11	25	3	150	25	50	0,563	TC060	T8	
	S570	D25 d25 Z03 L200 BDMT 11	25	3	200	25	60	0,764	TC060	T8	
	S572	D32 d32 Z04 L150 BDMT 11	32	4	150	32	50	0,961	TC060	T8	
	S574	D32 d32 Z04 L200 BDMT 11	32	4	200	32	60	1,294	TC060	T8	
<i>Compatible with /Kompatible für (KYCRA)</i>											

BDMT 1704	Order Code	Product Code	Dimensions (mm)					TC073	T15	BDMT 1704	
			D	Z	L	d	L1				
	S578	D25 d25 Z02 L120 BDMT 17	25	2	120	25	35	0,432	TC073	T15	
	S579	D25 d25 Z02 L150 BDMT 17	25	2	150	25	50	0,548	TC073	T15	BDMT 1704
	S581	D32 d25 Z03 L120 BDMT 17	32	3	120	25	40	0,480	TC073	T15	KYCRA.
	S582	D32 d32 Z03 L150 BDMT 17	32	3	150	32	60	0,895	TC074	T15	
	S584	D40 d32 Z04 L120 BDMT 17	40	4	120	32	40	0,790	TC074	T15	
	S585	D40 d32 Z04 L150 BDMT 17	40	4	150	32	40	0,985	TC074	T15	
<i>Compatible with /Kompatible für (KYCRA)</i>											

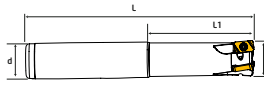
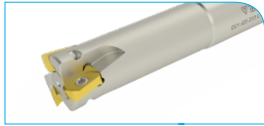
**LOGU 0303**

Order Code	Product Code	Dimensions (mm)						TC	S	ISO
		D	Z	L	d	L1	kg			
S677	D16 d16 Z02 L150 LOGU 03	16	2	150	16	50	0,219	TC064-2	T8	
S678	D20 d20 Z03 L150 LOGU 03	20	3	150	20	60	0,356	TC064-2	T8	LOGU 0303
S679	D21 d20 Z03 L150 LOGU 03	21	3	150	20	60	0,365	TC064-2	T8	KYCR
S680	D25 d25 Z04 L150 LOGU 03	25	4	150	25	60	0,579	TC064-2	T8	

Compatible with/ Kompatible für (KYCRA)

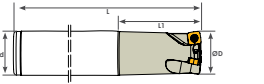
**SDMT 09T3**

Order Code	Product Code	Dimensions (mm)						TC	S	ISO
		D	Z	L	d	L1	kg			
S395	D25 d25 Z02 L150 SDMT 09	25	2	150	25	60	0,573	TC067	T15	SDMT 09T3
S396	D32 d32 Z03 L150 SDMT 09	32	3	150	32	60	0,934	TC067	T15	ZCC.

Compatible with/ Kompatible für (ZCC)

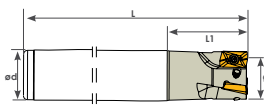
**BOMT 1304**

Order Code	Product Code	Dimensions (mm)						TC	S	ISO
		D	Z	L	d	L1	kg			
S850	D20 d20 Z02 L120 BOMT 13	20	2	120	20	40	0,289	TC069	T10	
S851	D20 d20 Z02 L150 BOMT 13	20	2	150	20	40	0,356	TC069	T10	BOMT 1304
S852	D25 d25 Z03 L120 BOMT 13	25	3	120	25	40	0,451	TC069	T10	INGRSLL.
S853	D25 d25 Z03 L150 BOMT 13	25	3	150	25	40	0,556	TC069	T10	

Compatible with/ Kompatible für (INGRSLL)

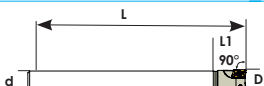
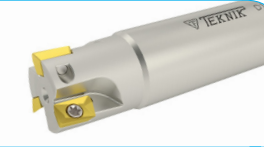
**ADMX 0702**

Order Code	Product Code	Dimensions (mm)						TC	S	ISO
		D	Z	L	d	L1	kg			
S751	D10 d10 Z02 L080 ADMX 07	10	2	80	10	16	0,062	TC058	T6	
S759	D16 d16 Z03 L160 ADMX 07	16	3	160	16	18	0,205	TC058	T6	ADMX 0702
S760	D20 d20 Z04 L125 ADMX 07	20	4	125	20	17	0,293	TC058	T6	PRMT.
S761	D20 d20 Z05 L125 ADMX 07	20	5	125	20	17	0,300	TC058	T6	

Compatible with/ Kompatible für (PRMT)

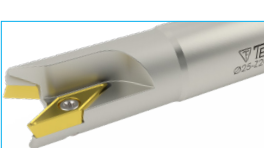
**VCGT 1604**

Order Code	Product Code	Dimensions (mm)						TC	S	ISO
		D	Z	L	d	L1	kg			
S710	D25 d25 Z02 L150 VCGT 16	25	2	150	25	50	0,518	TC074	T15	
S712	D32 d32 Z02 L150 VCGT 16	32	2	150	32	60	0,852	TC074	T15	VCGT 1604
S714	D40 d32 Z03 L150 VCGT 16	40	3	150	32	60	0,951	TC074	T15	ISO.
S718	D25 d25 Z02 L200 VCGT 16	25	2	200	25	60	0,730	TC074	T15	
S720	D32 d32 Z02 L200 VCGT 16	32	2	200	32	60	1,225	TC074	T15	
S724	D25 d25 Z02 L250 VCGT 16	25	2	250	25	60	0,920	TC074	T15	
S726	D32 d32 Z02 L250 VCGT 16	32	2	250	32	60	1,250	TC074	T15	

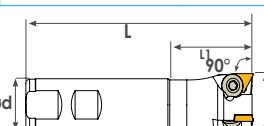
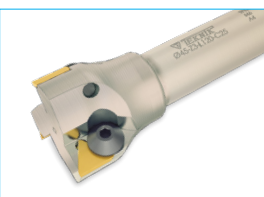
**TPKN 1103-1603-2204**

Order Code	Product Code	Dimensions (mm)						TC	S	ISO
		D	Z	L	d	L1	kg			
S116	D22 d20 Z02 L120 TPKN 11	22	2	120	20	45	0,301	TC050	3 Allen	
S118	D25 d25 Z02 L120 TPKN 11	25	2	120	25	45	0,438	TC050	3 Allen	TPKN 1103
S124	D32 d25 Z03 L120 TPKN 11	32	3	120	25	45	0,480	TC050	3 Allen	ISO
S128	D35 d25 Z02 L120 TPKN 16	35	2	120	25	45	0,507	TC052	4 Allen	TPKN 1603
S130	D40 d25 Z03 L120 TPKN 16	40	3	120	25	45	0,552	TC052	4 Allen	ISO
S132	D45 d25 Z03 L120 TPKN 16	45	3	120	25	45	0,606	TC052	4 Allen	
S134	D50 d32 Z03 L120 TPKN 22	50	3	120	32	55	0,896	TC054	5 Allen	TPKN 2204 ISO

### LNGU 15T6

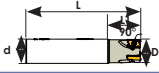

Order Code	Product Code	Dimensions (mm)						TC	TC	T	ISO
		D	Z	L	d	L1	kg				
S950	D25 d25 Z02 L150 LNGU 15	25	2	150	25	45	0,547	TC074	T15	LNGU 15T6	
S951	D32 d32 Z03 L150 LNGU 15	32	3	150	32	45	0,884	TC074	T15	KNNMTL	

*Compatible with. / Kompatible für (KNNMTL)*

### RDMT 1003

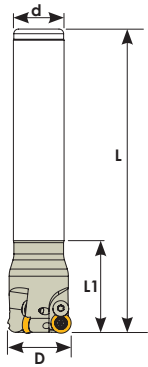
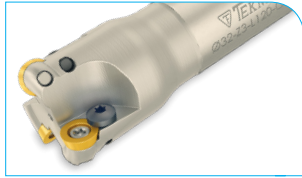

Order Code	Product Code	Dimensions (mm)						TC	TC	T	ISO
		D	Z	L	d	L1	kg				
R190	D20 d20 Z02 L120 RDMT 10	20	2	120	20	55	0,265	TC071	TC040	T15	
R192	D25 d25 Z02 L120 RDMT 10	25	2	120	25	50	0,435	TC067	TC040	T15	
R193	D30 d25 Z03 L120 RDMT 10	30	3	120	25	40	0,468	TC067	TC040	T15	
R194	D32 d25 Z03 L120 RDMT 10	32	3	120	25	40	0,484	TC067	TC040	T15	
R196	D35 d25 Z03 L120 RDMT 10	35	3	120	25	45	0,508	TC067	TC040	T15	RDMT 1003
R198	D40 d25 Z04 L120 RDMT 10	40	4	120	25	45	0,558	TC067	TC040	T15	ISO.
R200	D20 d20 Z02 L150 RDMT 10	20	2	150	20	60	0,336	TC067	TC040	T15	
R202	D25 d25 Z02 L150 RDMT 10	25	2	150	25	60	0,544	TC067	TC040	T15	
R203	D30 d25 Z03 L150 RDMT 10	30	3	150	25	40	0,586	TC067	TC040	T15	
R204	D32 d32 Z03 L150 RDMT 10	32	3	150	32	45	0,898	TC067	TC040	T15	
R206	D35 d32 Z03 L150 RDMT 10	35	3	150	32	45	0,923	TC067	TC040	T15	
R208	D40 d32 Z04 L150 RDMT 10	40	4	150	32	45	0,967	TC067	TC040	T15	
R210	D20 d20 Z02 L200 RDMT 10	20	2	200	20	80	0,477	TC067	TC040	T15	
R212	D25 d25 Z02 L200 RDMT 10	25	2	200	25	70	0,747	TC067	TC040	T15	
R213	D30 d25 Z03 L200 RDMT 10	30	3	200	25	40	0,789	TC067	TC040	T15	
R214	D32 d32 Z03 L200 RDMT 10	32	3	200	32	45	1,273	TC067	TC040	T15	
R216	D35 d32 Z03 L200 RDMT 10	35	3	200	32	45	1,227	TC067	TC040	T15	
R218	D40 d32 Z04 L200 RDMT 10	40	4	200	32	45	1,281	TC067	TC040	T15	

### RDMT 12T3

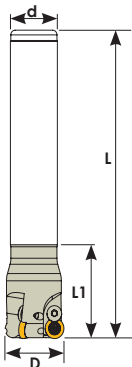
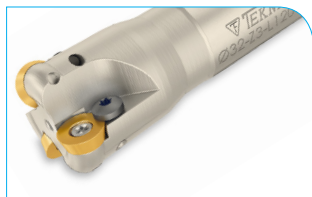

Order Code	Product Code	Dimensions (mm)						TC	TC	T	ISO
		D	Z	L	d	L1	kg				
R228	D25 d25 Z02 L120 RDMT 12	25	2	120	25	50	0,422	TC067	T15	TC040	
R229	D30 d25 Z02 L120 RDMT 12	30	2	120	25	40	0,456	TC067	T15	TC040	
R230	D32 d25 Z03 L120 RDMT 12	32	3	120	25	40	0,473	TC067	T15	TC040	
R232	D35 d25 Z03 L120 RDMT 12	35	3	120	25	40	0,485	TC067	T15	TC040	
R234	D40 d25 Z03 L120 RDMT 12	40	3	120	25	40	0,513	TC067	T15	TC040	RDMT 12T3
R236	D25 d25 Z02 L150 RDMT 12	25	2	150	25	60	0,539	TC067	T15	TC040	ISO.
R237	D30 d25 Z02 L150 RDMT 12	30	2	150	25	55	0,536	TC067	T15	TC040	
R238	D32 d32 Z03 L150 RDMT 12	32	3	150	32	45	0,876	TC067	T15	TC040	
R240	D35 d32 Z03 L150 RDMT 12	35	3	150	32	45	0,900	TC067	T15	TC040	
R242	D40 d32 Z03 L150 RDMT 12	40	3	150	32	45	0,956	TC067	T15	TC040	
R244	D25 d25 Z02 L200 RDMT 12	25	2	200	25	70	0,740	TC067	T15	TC040	
R245	D30 d25 Z02 L200 RDMT 12	30	2	200	25	55	0,784	TC067	T15	TC040	
R246	D32 d32 Z03 L200 RDMT 12	32	3	200	32	45	1,201	TC067	T15	TC040	
R248	D35 d32 Z03 L200 RDMT 12	35	3	200	32	45	1,226	TC067	T15	TC040	
R250	D40 d32 Z03 L200 RDMT 12	40	3	200	32	45	1,287	TC067	T15	TC040	
R255	D30 d25 Z02 L300 RDMT 12	30	2	300	25	55	1,168	TC067	T15	TC040	
R256	D32 d32 Z03 L300 RDMT 12	32	3	300	32	70	1,829	TC067	T15	TC040	
R258	D35 d32 Z03 L300 RDMT 12	35	3	300	32	45	1,855	TC067	T15	TC040	
R260	D40 d32 Z03 L300 RDMT 12	40	3	300	32	45	1,995	TC067	T15	TC040	

**Kalite için TEKNİK çözüm**  
**Technical solution for quality**



## Modular End Mill



[www.teknikcuttingtools.com](http://www.teknikcuttingtools.com)



Kalite için TEKNİK çözüm  
Technical solution for quality

38-41

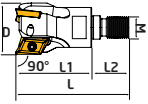

XEKT 1904	Order Code	Product Code	Dimensions (mm)							TC075-1	T15	XEKT 1904
			D	Z	M	L	L1	L2	kg			
	VT260	D25 Z02 M12 XEKT 19	25	2	M12	79	55	24	0,120			
	VT261	D32 Z02 M16 XEKT 19	32	2	M16	82	55	28	0,230			KRLY
	VT262	D40 Z03 M16 XEKT 19	40	3	M16	82	55	28	0,307			

*Compatible with / Kompatible für (KRLY)*

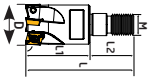
APMT 0602	Order Code	Product Code	Dimensions (mm)							TC057-1	T6	APMT 0603
			D	Z	M	L	L1	L2	kg			
	VT220	D10 Z02 M06 APMT 06	10	2	M06	41	25	16	0,011			
	VT221	D12 Z03 M06 APMT 06	12	3	M06	40	25	15	0,015			KRLY
	VT222	D16 Z04 M08 APMT 06	16	4	M08	42	25	17	0,030			
	VT223	D20 Z05 M10 APMT 06	20	5	M10	51	31	20	0,064			

*Compatible with / Kompatible für (KRLY)*

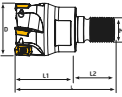
APMT 0903	Order Code	Product Code	Dimensions (mm)							TC060	T8	APMT 0903
			D	Z	M	L	L1	L2	kg			
	VT224	D16 Z02 M08 APMT 09	16	2	M08	41	25	16	0,040			
	VT225	D20 Z03 M10 APMT 09	20	3	M10	48	30	18	0,071			KRLY
	VT226	D25 Z04 M12 APMT 09	25	4	M12	57	35	22	0,116			
	VT227	D32 Z05 M16 APMT 09	32	5	M16	65,3	40	25,3	0,229			
	VT228	D35 Z05 M16 APMT 09	35	5	M16	65,3	40	25,3	0,261			
	VT229	D40 Z06 M16 APMT 09	40	6	M16	65,3	40	25,3	0,299			

*Compatible with / Kompatible für (KRLY)*

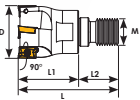
APXT 1003	Order Code	Product Code	Dimensions (mm)							TC060	T8	APXT 1003
			D	Z	M	L	L1	L2	kg			
	VT136	D16 Z02 M08 APXT 10	16	2	M08	41	25	16	0,050			
	VT138	D20 Z03 M10 APXT 10	20	3	M10	55	35	20	0,097			KRLY
	VT140	D25 Z03 M12 APXT 10	25	3	M12	55	33	22	0,135			
	VT143	D32 Z04 M16 APXT 10	32	4	M16	60	36	24,5	0,195			
	VT146	D35 Z04 M16 APXT 10	35	4	M16	60	36	24,5	0,225			
	VT148	D40 Z05 M16 APXT 10	40	5	M16	60	36	24,5	0,266			
	VT150	D42 Z05 M16 APXT 10	42	5	M16	60	36	24,5	0,294			

*Compatible with / Kompatible für (KRLY)*

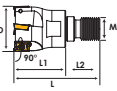
AP-- 1604	Order Code	Product Code	Dimensions (mm)							TC074	T15	AP-- 1604
			D	Z	M	L	L1	L2	kg			
	VT160	D25 Z02 M12 AP--16	25	2	M12	55	33	22	0,107			
	VT163	D32 Z03 M16 AP--16	32	3	M16	60	24	24,5	0,180			KRLY
	VT166	D35 Z03 M16 AP--16	35	3	M16	60	24	24,5	0,211			
	VT168	D40 Z04 M16 AP--16	40	4	M16	60	24	24,5	0,238			
	VT170	D42 Z04 M16 AP--16	42	4	M16	60	24	24,5	0,251			

*Compatible with / Kompatible für (KRLY)*

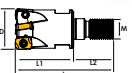
LNMX 0603	Order Code	Product Code	Dimensions (mm)							TC065	T8	LNMX 0603
			D	Z	M	L	L1	L2	kg			
	VT152	D16 Z02 M08 LNMX 06	16	2	M08	42	25	17	0,031			
	VT153	D20 Z03 M10 LNMX 06	20	3	M10	51	30	21	0,060			KRLY
	VT154	D25 Z04 M12 LNMX 06	25	4	M12	59	35	24	0,120			
	VT155	D32 Z05 M16 LNMX 06	32	5	M16	67	40	27	0,227			

*Compatible with / Kompatible für (KRLY)*

**BLMP 0603**

Order Code	Product Code	Dimensions (mm)							TC	Hole	Insert	Image
		D	Z	M	L	L1	L2	kg				
VT190	D16 Z02 M08 BLMP 06	16	2	M08	41	25	16	0,044	TC064	T8		
VT191	D20 Z03 M10 BLMP 06	20	3	M10	48	30	18	0,081	TC064	T8	BLMP 0603	
VT192	D25 Z04 M12 BLMP 06	25	4	M12	57	35	22	0,119	TC064	T8	TGTC.	
VT193	D32 Z05 M16 BLMP 06	32	5	M16	65	40	25	0,233	TC064	T8		
VT194	D35 Z05 M16 BLMP 06	35	5	M16	65	40	25	0,240	TC064	T8		
VT195	D40 Z06 M16 BLMP 06	40	6	M16	68	43	25	0,291	TC064	T8		
VT196	D42 Z06 M16 BLMP 06	42	6	M16	68	43	25	0,313	TC064	T8		

Compatible with / Kompatibel für (TGTC)

**LNMU 0303**

Order Code	Product Code	Dimensions (mm)							TC	Hole	Insert	Image
		D	Z	M	L	L1	L2	kg				
VT300	D16 Z02 M08 LNMU 03	16	2	M08	42	25	17	0,029	TC063	T8		
VT302	D20 Z03 M10 LNMU 03	20	3	M10	49	30	19	0,061	TC063	T8	LNMU 0303	
VT304	D25 Z04 M12 LNMU 03	25	4	M12	57	35	22	0,108	TC063	T8	TNGLY-OKE	
VT305	D32 Z05 M16 LNMU 03	32	5	M16	63	40	23	0,227	TC063	T8		
VT307	D40 Z06 M16 LNMU 03	40	6	M16	63	40	23	0,272	TC063	T8		

Compatible with / Kompatibel für (TNGLY-OKE)

**XNEX 0403**

Order Code	Product Code	Dimensions (mm)							TC	Hole	Insert	Image
		D	Z	M	L	L1	L2	kg				
VT244	D17 Z02 M8 XNEX 04	17	2	M8	41	25	16	0,035	TC061	T8	XNEX 0403	
VT245	D20 Z03 M10 XNEX 04	20	3	M10	46	28	18	0,073	TC061	T8	SCO	
VT247	D25 Z04 M12 XNEX 04	25	4	M12	52	30	22	0,115	TC061	T8	XNEX 0403	
VT249	D32 Z05 M16 XNEX 04	32	5	M16	65	40	25	0,253	TC061	T8	SCO	

Compatible with SCO insert / Kompatibel für (SCO)

**LOGU 0303**

Order Code	Product Code	Dimensions (mm)							TC	Hole	Insert	Image
		D	Z	M	L	L1	L2	kg				
VT310	D16 Z02 M08 LOGU 03	16	2	M08	46	30	16	0,030	TC064-2	T8		
VT312	D20 Z03 M10 LOGU 03	20	3	M10	54	34	20	0,060	TC064-2	T8	LOGU 0303	
VT314	D25 Z04 M12 LOGU 03	25	4	M12	57	35	22	0,097	TC064-2	T8	KYCR	
VT316	D32 Z05 M16 LOGU 03	32	5	M16	65	40	25	0,210	TC064-2	T8		
VT318	D35 Z05 M16 LOGU 03	35	5	M16	65	40	25	0,230	TC064-2	T8		
VT319	D40 Z05 M16 LOGU 03	40	5	M16	68	45	23	0,316	TC064-2	T8		

Compatible with / Kompatibel für (KYCR)

**SDMT 09T3**

Order Code	Product Code	Dimensions (mm)							TC	Hole	Insert	Image
		D	Z	M	L	L1	L2	kg				
VT240	D32 Z03 M16 SDMT 09	32	3	M16	69	40	29	0,211	TC067	T15	SDMT 09T3	
VT241	D35 Z03 M16 SDMT 09	35	3	M16	69	40	29	0,231	TC067	T15	ZCC.	
VT242	D40 Z04 M16 SDMT 09	40	3	M16	69	40	29	0,253	TC067	T15		

Compatible with / Kompatibel für (ZCC)

### ADMX 0702



Order Code	Product Code	Dimensions (mm)							TC	TC	T	Icon
		D	Z	M	L	L1	L2	kg				
VT200	D16 Z04 M08 ADMX 07	16	4	M08	41	23	18	0,041	TC058	TC058	T6	ADMX 0702
VT201	D20 Z05 M10 ADMX 07	20	5	M10	49	30	19	0,080	TC058	TC058	T6	PRMT.
VT203	D32 Z08 M16 ADMX 07	32	8	M16	66	43	23	0,235	TC058	TC058	T6	

Compatible with / Kompatible für (PRMT)

### RDMT 1003

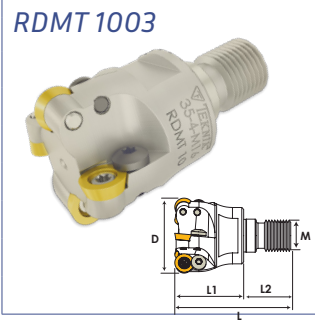

Order Code	Product Code	Dimensions (mm)							TC	TC	T	Icon
		D	Z	M	L	L1	L2	kg				
VT098	D20 Z02 M10 RDMT 10	20	2	M10	55	35	20	0,087	TC071	TC040	T15	
VT100	D25 Z03 M12 RDMT 10	25	3	M12	55	33	22	0,114	TC067	TC040	T15	RDMT 1003
VT103	D32 Z03 M16 RDMT 10	32	3	M16	60	35,5	24,5	0,188	TC067	TC040	T15	ISO.
VT106	D35 Z04 M16 RDMT 10	35	4	M16	60	35,5	24,5	0,201	TC067	TC040	T15	
VT107	D35 Z05 M16 RDMT 10	35	5	M16	60	35,5	24,5	0,211	TC067	TC040	T15	
VT108	D40 Z05 M16 RDMT 10	40	5	M16	60	35,5	24,5	0,241	TC067	TC040	T15	
VT110	D42 Z05 M16 RDMT 10	42	5	M16	60	35,5	24,5	0,265	TC067	TC040	T15	

### RDMT 12T3



Order Code	Product Code	Dimensions (mm)							TC	TC	T	Icon
		D	Z	M	L	L1	L2	kg				
VT120	D25 Z02 M12 RDMT 12	25	2	M12	55	33	22	0,106	TC067	TC040	T15	
VT123	D32 Z03 M16 RDMT 12	32	3	M16	60	35,5	24,5	0,177	TC067	TC040	T15	RDMT 12T3
VT126	D35 Z03 M16 RDMT 12	35	3	M16	60	35,5	24,5	0,196	TC067	TC040	T15	ISO.
VT128	D40 Z04 M16 RDMT 12	40	4	M16	60	35,5	24,5	0,230	TC067	TC040	T15	
VT130	D42 Z04 M16 RDMT 12	42	4	M16	60	35,5	24,5	0,237	TC067	TC040	T15	

### RPMT 10-12

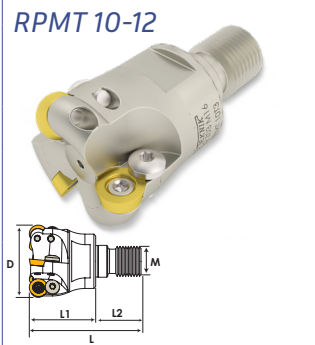

Order Code	Product Code	Dimensions (mm)							TC	TC	T	Icon
		D	Z	M	L	L1	L2	kg				
VT180	D25 Z03 M12 RPMT 10	25	3	M12	55	33	22	0,084	TC067	TC040	T15	RPMT 10
VT182	D32 Z03 M16 RPMT 10	32	3	M16	68	36	24,5	0,189	TC067	TC040	T15	MTSBSH.
VT174	D25 Z02 M12 RPMT 12	25	2	M12	55	33	22	0,109	TC073	-----	T15	RPMT 12
VT176	D32 Z03 M16 RPMT 12	32	3	M16	60	34,7	25,3	0,164	TC073	-----	T15	MTSBSH.

Compatible with / Kompatible für (MTSBSH)

### EPMT 0603



Order Code	Product Code	Dimensions (mm)							TC	TC	T	Icon
		D	Z	M	L	L1	L2	kg				
VT230	D16 Z02 M08 EPMT 06	16	2	M08	41	16	25	0,040	TC060	TC060	T8	
VT231	D20 Z03 M10 EPMT 06	20	3	M10	48	18	30	0,070	TC060	TC060	T8	
VT232	D25 Z04 M12 EPMT 06	25	4	M12	55	20	35	0,110	TC060	TC060	T8	EPMT 0603
VT233	D32 Z05 M16 EPMT 06	32	5	M16	60	25,3	34,7	0,197	TC060	TC060	T8	HTCH.
VT234	D35 Z05 M16 EPMT 06	35	5	M16	60	25,3	34,7	0,224	TC060	TC060	T8	
VT235	D40 Z06 M16 EPMT 06	40	6	M16	60	25,3	34,7	0,256	TC060	TC060	T8	
VT236	D42 Z06 M16 EPMT 06	42	6	M16	65,3	25,3	40	0,300	TC060	TC060	T8	

Compatible with / Kompatible für (HTCH)

## Modular End Mill Holder

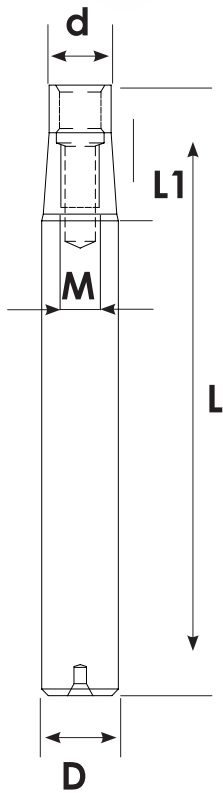

Order Code	Product Code	Dimensions (mm)						
		D	d	L	L1	M		
VT500	D15 d12 L150 M8	15	12,7	150	30	M8	0,208	
VT501	D15 d12 L150 M8-IC	15	12,7	150	30	M8	0,202	
VT502	D16 d14 L100 M8	16	14	100	30	M8	0,153	
VT503	D16 d14 L100 M8-IC	16	14	100	30	M8	0,150	
VT504	D16 d14 L150 M8	16	14	150	30	M8	0,234	
VT505	D16 d14 L150 M8-IC	16	14	150	30	M8	0,230	
VT506	D19 d17 L150 M10	19	17,7	150	30	M10	0,329	
VT507	D19 d17 L150 M10-IC	19	17,7	150	30	M10	0,324	
VT508	D20 d17 L100 M10	20	17,7	100	30	M10	0,238	
VT509	D20 d17 L100 M10-IC	20	17,7	100	30	M10	0,235	
VT510	D20 d17 L150 M10	20	17,7	150	40	M10	0,357	
VT511	D20 d17 L150 M10-IC	20	17,7	150	40	M10	0,354	
VT512	D24 d20 L150 M12	24	20,7	150	40	M12	0,508	
VT513	D24 d20 L150 M12-IC	24	20,7	150	40	M12	0,502	
VT514	D25 d20 L150 M12	25	20,7	150	40	M12	0,546	
VT515	D25 d20 L150 M12-IC	25	20,7	150	40	M12	0,542	
VT516	D25 d20 L200 M12	25	20,7	200	40	M12	0,680	
VT517	D25 d20 L200 M12-IC	25	20,7	200	40	M12	0,675	
VT518	D25 d20 L250 M12	25	20,7	250	40	M12	0,700	
VT519	D25 d20 L250 M12-IC	25	20,7	250	40	M12	0,695	
VT520	D32 d28 L170 M16	32	28,7	170	40	M16	0,790	
VT521	D32 d28 L170 M16-IC	32	28,7	170	40	M16	0,784	
VT522	D32 d28 L220 M16	32	28,7	220	40	M16	0,860	
VT523	D32 d28 L220 M16-IC	32	28,7	220	40	M16	0,854	
VT524	D32 d28 L300 M16	32	28,7	300	40	M16	1,380	
VT525	D32 d28 L300 M16 -IC	32	28,7	300	40	M16	1,375	

IC Codes are coolant.



# Boring Tools Finish Ausdrehwerkzeug für die Fertigbearbeitung

Superior Smoothness – Resistant to  
abrasion and harsh conditions.  
High Efficiency – Less processing  
time, more productivity.

Technical Solution For Quality!

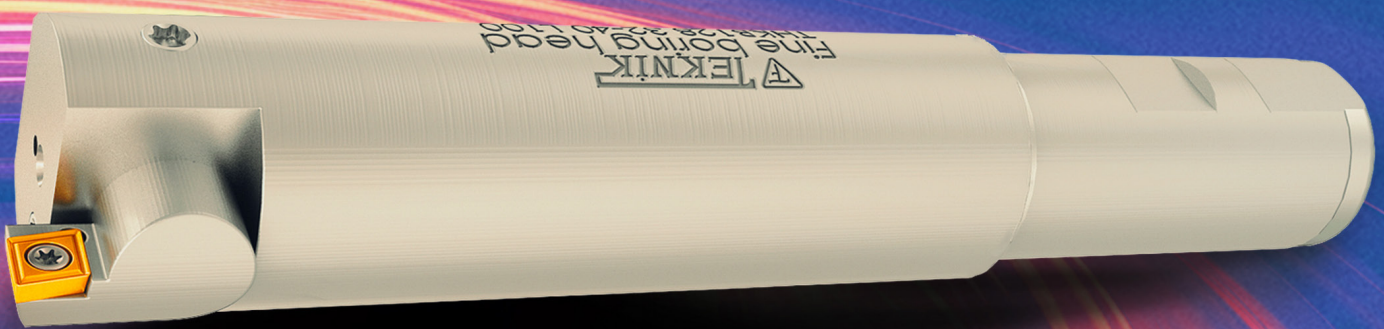

 **TEKNIK**  
Cutting Tools



[technikcuttingtools.com](http://technikcuttingtools.com)



+90 332 345 08 45

## Boring Tools



[www.teknikcuttingtools.com](http://www.teknikcuttingtools.com)



Kalite için TEKNIK çözüm  
Technical solution for quality

42-48



THB 01 SET 9-130 mm

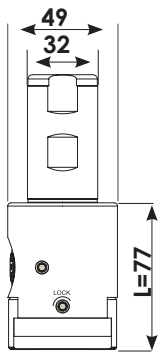
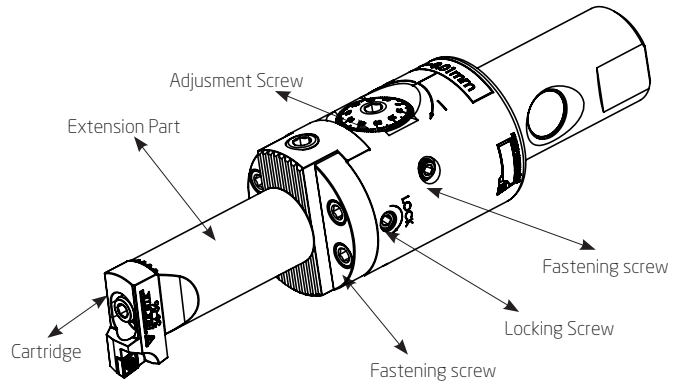
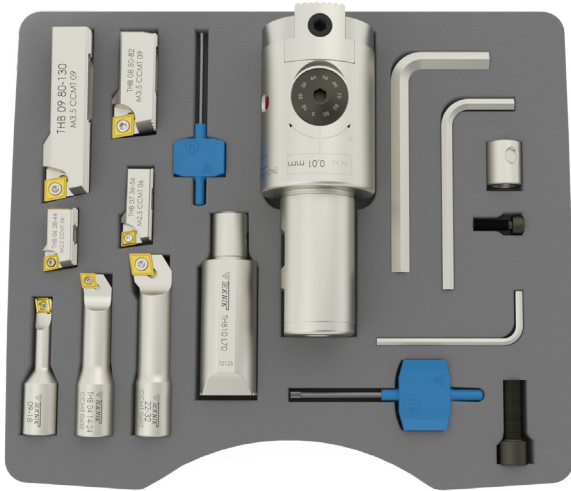

**THB 02**  
**GÖVDE**  
**BODY**  
**Fine / Fein**

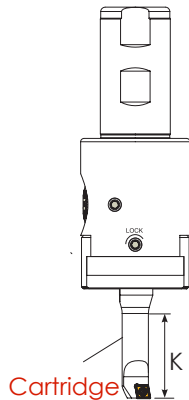
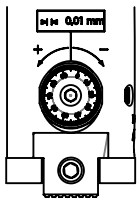

Cartridge

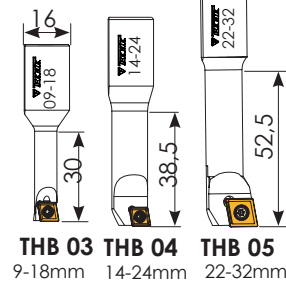

**THB 03** 9-18mm  
**THB 04** 14-24mm  
**THB 05** 22-32mm

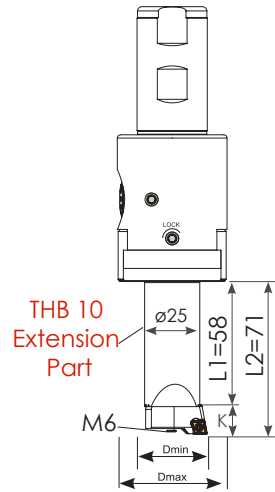

THB 10  
Extension  
Part

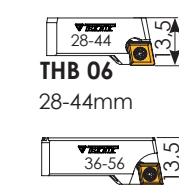

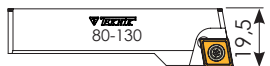
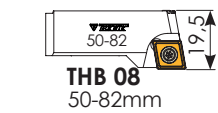
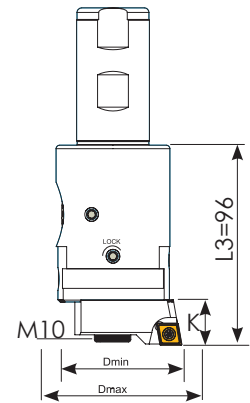

**THB 06**  
28-44mm  
**THB 07**  
36-56mm

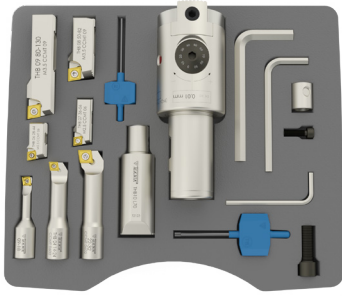

**THB 08**  
50-82mm  
**THB 09**  
80-30mm

	Order Code	Product Code	K	L1	L2	L3	Dmin - Dmax		
	THB03	09-18 Cartridge	32,5	...	...	...	9-18	-	CCMT 0602
	THB04	14-24 Cartridge	39,6	...	...	...	14-24	-	CCMT 0602
	THB05	22-32 Cartridge	52,5	...	...	...	22-32	-	CCMT 0903
	THB06	28-44 Cartridge	13,7	...	71	...	28-44	-	CCMT 0602
	THB07	36-56 Cartridge	13,7	...	71	...	36-56	-	CCMT 0602
	THB08	50-82 Cartridge	19,5	...	...	95,5	50-82	-	CCMT 0903
	THB09	80-130 Cartridge	19,5	...	...	95,5	80-130	-	CCMT 0903
	THB10	Extension Part	...	58	...	...	...	-	...





Order Code	Product Code	Dmin - Dmax	
THB01	Boring Tools Finish SETİ / SET	9-130	3,100



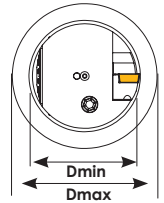
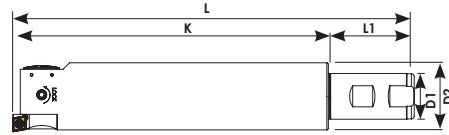

Order Code	Product Code	Dmin - Dmax	
THB02	BODY	...	-



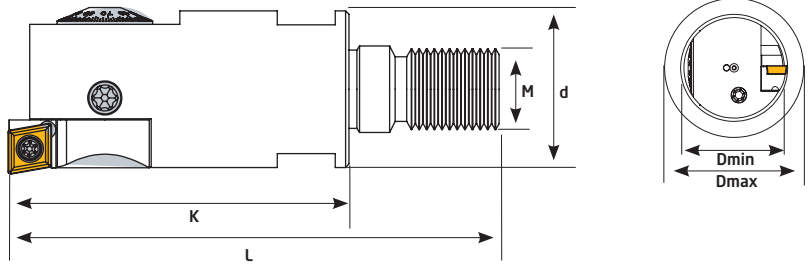

Order Code	Product Code	Dimensions (mm)										Fine
		Dmin	Dmax	K	D1	L1	D2	L	 (mm)			
THKB120	25-32 K050 CCMT 06	25	32	50	25	56	23	106	0,402	CCMT 0602	0,02	
THKB122	25-32 K100 CCMT 06	25	32	100	25	56	23	156	0,570	ISO.		
THKB126	32-40 K060 CCMT 06	32	40	60	25	56	29	116	0,510		0,01	
THKB128	32-40 K104 CCMT 06	32	40	104	25	56	29	160	0,760			
THKB132	40-50 K069 CCMT 06	40	50	69	25	56	36	125	0,722	CCMT 0602		
THKB134	40-50 K109 CCMT 06	40	50	109	25	56	36	165	1,085			
THKB136	40-50 K189 CCMT 06	40	50	189	25	56	36	245	1,723			
THKB138	50-65 K065 CCMT 09	50	65	65	32	60	47	125	1,231		0,01	
THKB140	50-65 K130 CCMT 09	50	65	130	32	60	47	190	2,135	CCMT 0903		
THKB142	50-65 K220 CCMT 09	50	65	220	32	60	47	280	3,383	ISO.		
THKB144	65-80 K085 CCMT 09	65	80	85	32	60	60	145	1,900			
THKB146	65-80 K130 CCMT 09	65	80	130	32	60	60	190	2,547			
THKB148	65-80 K220 CCMT 09	65	80	220	32	60	60	280	3,895			

### 25-40 mm Boring Tools Finish



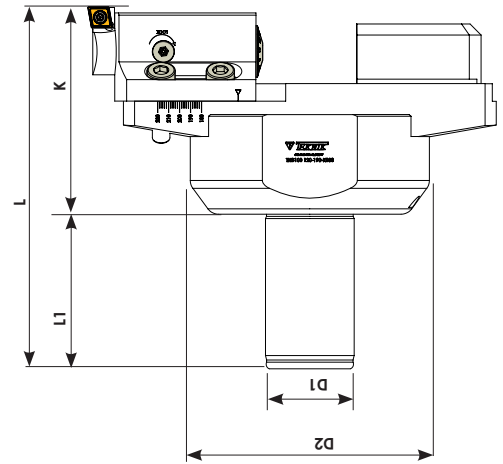
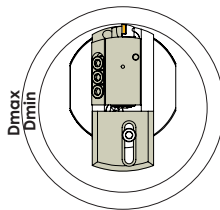

Order Code	Product Code	Dimensions (mm)								Fine → ← (mm)	
		Dmin	Dmax	M	K	L	d				
THKB102	25-32 K050 M12 CCMT 06	25	32	M12	50	72	23	0,194	<b>0,02</b>	CCMT 0602 ISO.	
THKB104	32-40 K050 M16 CCMT 06	32	40	M16	50	74,3	29	0,287	<b>0,01</b>	CCMT 0602 ISO.	

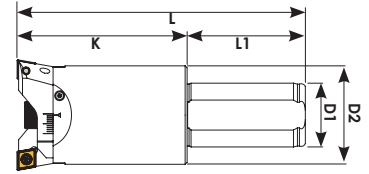
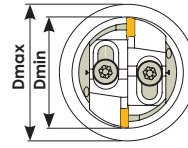

Order Code	Product Code	Dimensions (mm)								
		Dmin	Dmax	K	D1	L1	D2	L		
THB100	120-190 K093 CCMT 09	120	190	93,7	40	70	109	163,7	5,060	CCMT 0903
THB101	180-240 K093 CCMT 09	180	240	93,7	40	70	109	163,7	5,967	ISO.
THB102	240-300 K093 CCMT 09	240	300	93,7	40	70	109	163,7	7,000	



Order Code	Product Code	Dimensions (mm)								kg	 
		Dmin	Dmax	K	D1	L1	D2	L			
TKB088	16-20 K052 WCMX 03	16	20	52	16	48	15,7	100	0,176	WCMX 0302	
TKB090	16-20 K102 WCMX 03	16	20	102	16	48	15,7	150	0,237	ISO.	
TKB092	16-20 K152 WCMX 03	16	20	152	16	48	15,7	200	0,362		
TKB094	19-23 K052 CCMT 06	19	23	52	16	48	17,7	100	0,192		
TKB096	19-23 K102 CCMT 06	19	23	102	16	48	17,7	150	0,292	CCMT 0602	
TKB098	19-23 K152 CCMT 06	19	23	152	16	48	17,7	200	0,401	ISO.	
TKB100	23-28 K050 CCMT 06	23	28	50	20	50	21,2	100	0,298		
TKB102	23-28 K100 CCMT 06	23	28	100	20	50	21,2	150	0,347		
TKB104	23-28 K185 CCMT 06	23	28	185	20	50	21,2	235	0,682		
TKB106	28-38 K055 CCMT 09	28	38	55	20	50	25,7	105	0,378		
TKB108	28-38 K105 CCMT 09	28	38	105	20	50	25,7	155	0,376		
TKB110	28-38 K174 CCMT 09	28	38	174	25	56	25,7	230	0,267		
TKB111	28-38 K274 CCMT 09	28	38	274	25	56	25,7	330	1,342		
TKB112	37-48 K064 CCMT 09	37	48	64	25	56	32	120	0,661		
TKB114	37-48 K114 CCMT 09	37	48	114	25	56	33	170	0,991	CCMT 0903	
TKB116	37-48 K204 CCMT 09	37	48	204	25	56	33	260	1,597	ISO.	
TKB118	45-56 K070 CCMT 09	45	56	70	32	60	39,5	130	1,035		
TKB120	45-56 K120 CCMT 09	45	56	120	32	60	40	180	1,528		
TKB122	45-56 K200 CCMT 09	45	56	200	32	60	40	260	2,385		
TKB124	55-75 K085 CCMT 09	55	75	85	32	60	50	145	1,638		
TKB126	55-75 K135 CCMT 09	55	75	135	32	60	50	195	2,422		
TKB128	55-75 K220 CCMT 09	55	75	220	32	60	50	280	3,745		
TKB130	70-90 K085 CCMT 09	70	90	85	32	60	64	145	2,100		
TKB132	70-90 K135 CCMT 09	70	90	135	32	60	64	195	2,942		
TKB134	70-90 K220 CCMT 09	70	90	220	40	70	64	290	4,915		
TKB136	90-130 K115 CCMT 09	90	130	115	32	60	74	175	3,130		
TKB138	90-130 K165 CCMT 09	90	130	165	32	60	74	225	4,138		

Cartridge

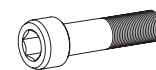
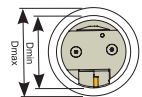
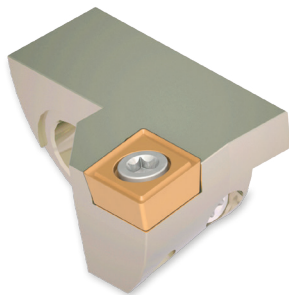

Order Code	Dmin-Dmax	
KR096	16-20	WCMX 0302
KR098	19-23	CCMT 0602
KR100	23-28	CCMT 0602
KR102	28-38	CCMT 09T3
KR104	37-48	CCMT 09T3
KR106	45-56	CCMT 09T3
KR108	55-75	CCMT 09T3
KR110	70-90	CCMT 09T3
KR112	90-130	CCMT 09T3
KR115	55-75	CCMT 1204
KR116	70-90	CCMT 1204
KR117	90-130	CCMT 1204

Order Code	Screw
TC102	M4x16
TC102	M4x16
TC104	M5x25
TC104	M5x25
TC106	M6x30
TC108	M8x25
TC108	M8x25
TC108	M8x25
TC108	M8x25
TC108	M8x25
TC108	M8x25
TC108	M8x25

16-38 mm Boring Tools

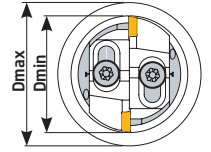
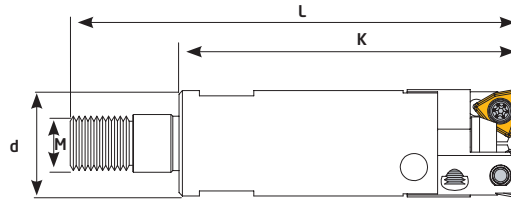

Order Code	Product Code	Dimensions (mm)									
		Dmin	Dmax	M	K	L	d				
TKB170	16-20 K050 M08 WCMX 03	16	20	M08	50	66	15,5	0,078		WCMX 0302 ISO.	
TKB172	19-23 K050 M10 CCMT 06	19	23	M10	50	70	17,5	0,095		CCMT 0602 ISO.	
TKB174	23-28 K050 M12 CCMT 06	23	28	M12	50	72	21,2	0,145		CCMT 0602 ISO.	
TKB176	28-38 K050 M16 CCMT 09	28	38	M16	50	74,5	25,7	0,213		CCMT 0903 ISO.	

120-350 mm Boring Tools

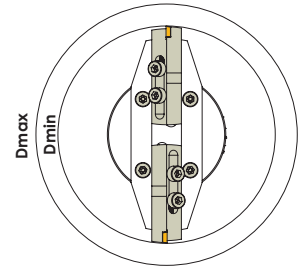
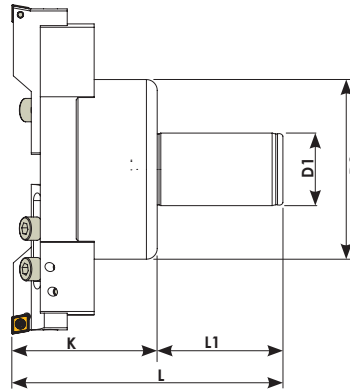

Order Code	Product Code	Dimensions (mm)									
		Dmin	Dmax	K	D1	L1	D2	L			
TKB148	120-170 K069 CCMT 12	120	170	69	40	70	115,5	139	3,281		CCMT 1204
TKB150	170-250 K084 CCMT 12	170	250	84	40	70	99,5	154	5,011		ISO.
TKB152	240-350 K084 CCMT 12	240	350	84	40	70	149,5	154	8,294		

Cartridge

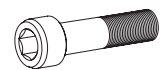
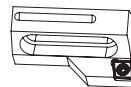
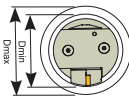
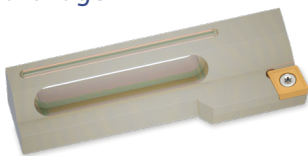



Order Code	Dmin-Dmax		Order Code	Screw
KR119	120-170	CC MT 1204	TC109	M8x25
KR120	170-250	CC MT 1204	TC109	M8x25
KR124	240-350	CC MT 1204	TC109	M8x25

15-90 mm Boring Tools

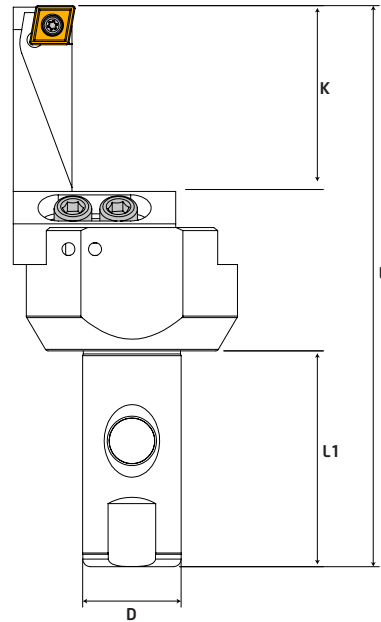
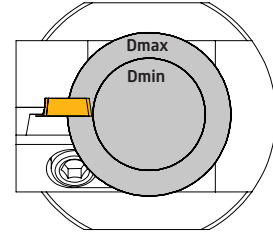
**NEW  
PRODUCT**



Order Code	Product Code	Dimensions (mm)								
		Dmin	Dmax	K	D	L	L1			
TKB180	15-45 K060 CCMT09	15	45	60	32	174	70	1,832	CCMT 0903	
TKB181	45-90 K060 CCMT09	45	90	60	32	182	70	2,168	ISO.	

# BORING TOOLS

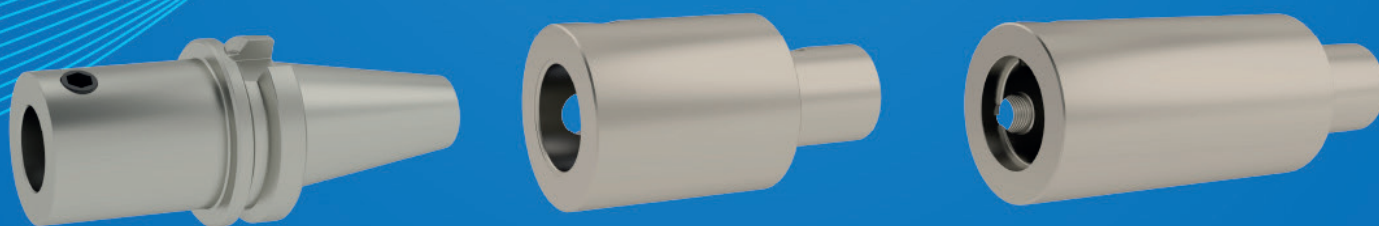

**BT40-SK40**



**Technical Solution  
for quality**

Technical Solution For Quality | [teknikcuttingtools.com](http://teknikcuttingtools.com)

# Shoulder Milling & Disc Milling



[www.teknikcuttingtools.com](http://www.teknikcuttingtools.com)

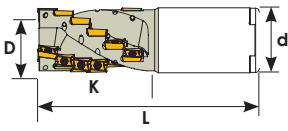
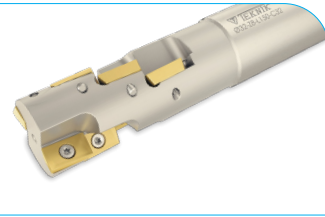

**AP-- 1604**

Order Code	Product Code	Dimensions (mm)								
		D	Z	K	d	L				
HF20	D32 Z06 K43 AP--16	32	6	43	32	125	0,658	TC074	T15	
HF22	D40 Z09 K43 AP--16	40	9	43	32	125	0,821	TC074	T15	AP-- 1604
HF24	D32 Z08 K58 AP--16	32	8	58	32	150	0,771	TC074	T15	KRLY
HF26	D40 Z12 K58 AP--16	40	12	58	32	150	0,950	TC074	T15	
HF30	D32 Z08 K58 AP--16	32	8	58	32	200	1,120	TC074	T15	
HF32	D40 Z12 K58 AP--16	40	12	58	32	200	1,280	TC074	T15	

*Compatible with / Kompatible für (KRLY)*

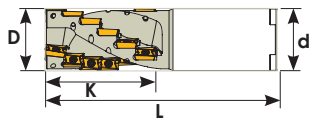
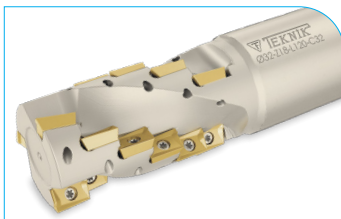
**APXT 1003**

Order Code	Product Code	Dimensions (mm)								
		D	Z	K	d	L				
HF06	D20 Z06 K28 APXT 10	20	6	28	20	120	0,265	TC060	T8	
HF07	D25 Z08 K37 APXT 10	25	8	37	25	120	0,404	TC060	T8	
HF08	D32 Z15 K46 APXT 10	32	15	46	32	120	0,627	TC060	T8	
HF09	D40 Z18 K55 APXT 10	40	18	55	32	125	0,873	TC060	T8	
HF10	D20 Z06 K28 APXT 10	20	6	28	20	150	0,326	TC060	T8	APXT 1003
HF11	D25 Z08 K37 APXT 10	25	8	37	25	150	0,515	TC060	T8	KRLY
HF12	D32 Z15 K46 APXT 10	32	15	46	32	150	1,120	TC060	T8	
HF13	D40 Z18 K55 APXT 10	40	18	55	32	150	1,100	TC060	T8	
HF15	D20 Z06 K28 APXT 10	20	6	28	20	200	0,481	TC060	T8	
HF16	D25 Z08 K37 APXT 10	25	8	37	25	200	0,727	TC060	T8	
HF17	D32 Z15 K46 APXT 10	32	15	46	32	200	1,144	TC060	T8	
HF18	D40 Z18 K55 APXT 10	40	18	55	32	200	1,621	TC060	T8	

*Compatible with / Kompatible für (KRLY)*

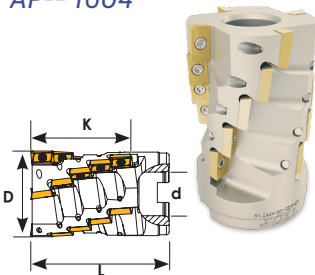
**AP-- 1604**

Order Code	Product Code	Dimensions (mm)								
		D	Z	K	d	L				
HF52	D63 Z20 K75 AP--16	63	20	75	32	100	1,455	TC074	T15	AP-- 1604
HF53	D80 Z25 K75 AP--16	80	25	75	32	100	2,645	TC074	T15	KRLY
HF54	D100 Z30 K75 AP--16	100	30	75	40	100	4,329	TC074	T15	

*Compatible with / Kompatible für (KRLY)*

**SCMT 09T3-1204**

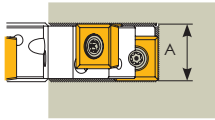
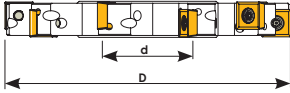
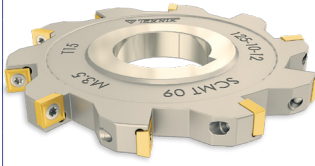

Order Code	Product Code	Dimensions (mm)					TC	T	ISO
		D	A	Z	d	kg			
DF086	D080 A10 Z08 SCMT 09	80	10	8	27	0,229	TC074	T15	
DF092	D100 A10 Z08 SCMT 09	100	10	8	32	0,408	TC074	T15	
DF100	D125 A10 Z10 SCMT 09	125	10	10	40	0,612	TC074	T15	
DF108	D160 A10 Z12 SCMT 09	160	10	12	40	1,280	TC074	T15	
DF116	D200 A10 Z14 SCMT 09	200	10	14	40	1,738	TC074	T15	
DF088	D080 A12 Z08 SCMT 09	80	12	8	27	0,445	TC074	T15	SCMT 09T3
DF094	D100 A12 Z08 SCMT 09	100	12	8	32	0,477	TC074	T15	ISO.
DF102	D125 A12 Z10 SCMT 09	125	12	10	40	0,748	TC074	T15	
DF110	D160 A12 Z12 SCMT 09	160	12	12	40	1,313	TC074	T15	
DF118	D200 A12 Z14 SCMT 09	200	12	14	40	2,140	TC074	T15	
DF090	D080 A16 Z08 SCMT 12	80	16	8	27	0,564	TC083	T20	
DF096	D100 A16 Z08 SCMT 12	100	16	8	32	0,353	TC083	T20	
DF104	D125 A16 Z10 SCMT 12	125	16	10	40	0,927	TC083	T20	SCMT 1204
DF112	D160 A16 Z12 SCMT 12	160	16	12	40	1,634	TC083	T20	ISO.
DF120	D200 A16 Z14 SCMT 12	200	16	14	40	2,769	TC083	T20	
DF106	D125 A20 Z10 SCMT 12	125	20	10	40	1,167	TC083	T20	
DF114	D160 A20 Z12 SCMT 12	160	20	12	40	2,145	TC083	T20	

**CCMT 0602-09T3-1204**

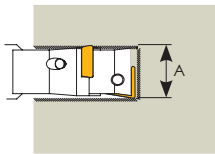
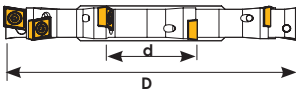
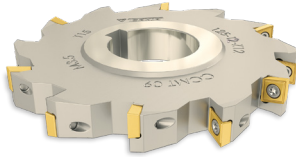

Order Code	Product Code	Dimensions (mm)					TC	T	ISO
		D	A	Z	d	kg			
DF150	D080 A08 Z10 CCMT 06	80	8	10	27	0,236	TC063	T8	
DF160	D100 A08 Z12 CCMT 06	100	8	12	32	0,365	TC063	T8	
DF170	D125 A08 Z14 CCMT 06	125	8	14	40	0,512	TC063	T8	
DF182	D160 A08 Z16 CCMT 06	160	8	16	40	0,996	TC063	T8	CCMT 0602
DF194	D200 A08 Z18 CCMT 06	200	8	18	40	1,587	TC063	T8	ISO.
DF152	D080 A10 Z10 CCMT 06	80	10	10	27	0,289	TC063	T8	
DF162	D100 A10 Z12 CCMT 06	100	10	12	32	0,453	TC063	T8	
DF172	D125 A10 Z14 CCMT 06	125	10	14	40	0,703	TC063	T8	
DF184	D160 A10 Z16 CCMT 06	160	10	16	40	1,228	TC063	T8	
DF196	D200 A10 Z18 CCMT 06	200	10	18	40	2,035	TC063	T8	
DF154	D080 A12 Z08 CCMT 09	80	12	8	27	0,470	TC067	T15	
DF164	D100 A12 Z10 CCMT 09	100	12	10	32	0,472	TC067	T15	
DF174	D125 A12 Z12 CCMT 09	125	12	12	40	0,750	TC067	T15	
DF186	D160 A12 Z14 CCMT 09	160	12	14	40	1,360	TC067	T15	CCMT 0903
DF198	D200 A12 Z16 CCMT 09	200	12	16	40	2,400	TC067	T15	ISO.
DF156	D080 A14 Z08 CCMT 09	80	14	8	27	0,335	TC067	T15	
DF166	D100 A14 Z10 CCMT 09	100	14	10	32	0,552	TC067	T15	
DF176	D125 A14 Z12 CCMT 09	125	14	12	40	0,871	TC067	T15	
DF188	D160 A14 Z14 CCMT 09	160	14	14	40	1,535	TC067	T15	
DF200	D200 A14 Z16 CCMT 09	200	14	16	40	2,575	TC067	T15	
DF158	D080 A16 Z06 CCMT 12	80	16	6	27	0,545	TC083	T20	
DF168	D100 A16 Z08 CCMT 12	100	16	8	32	0,567	TC083	T20	
DF178	D125 A16 Z10 CCMT 12	125	16	10	40	1,121	TC083	T20	CCMT 1204
DF190	D160 A16 Z12 CCMT 12	160	16	12	40	1,727	TC083	T20	ISO.
DF180	D125 A20 Z10 CCMT 12	125	20	10	40	1,430	TC083	T20	
DF192	D160 A20 Z12 CCMT 12	160	20	12	40	2,650	TC083	T20	

*Insert Clamping Systems*

# SHOULDER MILLING

Technical Solution For Quality



## T-Slot Milling Cutter



[www.teknikcuttingtools.com](http://www.teknikcuttingtools.com)



Kalite için TEKNİK çözüm

Technical solution for quality

54-56



CCMT 0602-09T3-1204

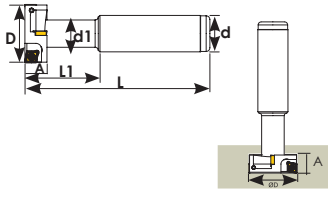
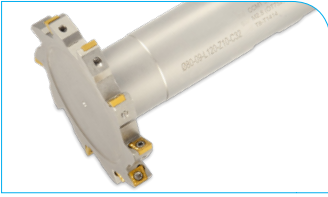

Order Code	Product Code	Dimensions (mm)								kg			
		D	A	Z	d	d1	L	L1					
TKÇ096	D17 A08 Z02 CCMT 06	17	8	2	16	10	100	28	0,145	TC060	T8	CCMT 0602	
TKÇ098	D21 A09 Z02 CCMT 06	21	9	2	16	11	100	31,5	0,151	TC060	T8	ISO.	
TKÇ100	D25 A11 Z04 CCMT 06	25	11	4	20	15	100	32,5	1,232	TC060	T8		
TKÇ102	D32 A12 Z04 CCMT 06	32	12	4	20	15	100	40	0,300	TC060	T8		
TKÇ103	D32 A14 Z04 CCMT 09	32	14	4	25	16	100	33	0,434	TC067	T15	CCMT 0903	
TKÇ104	D35 A15 Z04 CCMT 09	35	15	4	25	14	100	40	0,447	TC067	T15	ISO.	
TKÇ106	D40 A17 Z04 CCMT 09	40	17	4	25	20	110	50	0,509	TC067	T15		
TKÇ108	D50 A20 Z04 CCMT 12	50	20	4	32	26	110	50	0,691	TC083	T20	CCMT 1204 ISO	
TKÇ120	D63 A09 Z08 CCMT 06	63	9	8	32	19,5	125	37	0,842	TC060	T8	CCMT 0602	
TKÇ122	D80 A09 Z10 CCMT 06	80	9	10	31,5	32	120	32	1,025	TC060	T8	ISO.	

SPMG 05-06-07

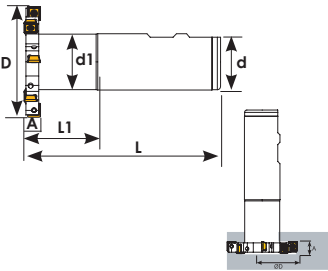
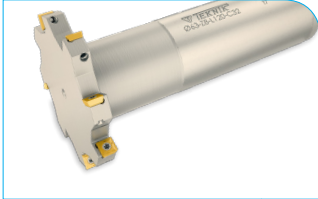

Order Code	Product Code	Dimensions (mm)								kg			
		D	A	Z	d	d1	L	L1					
TKÇ050	D50 A05 Z07 SPMG 05	50	5	7	32	31,5	120	45	0,830	TC058	T6	SPMG 05	
TKÇ052	D63 A05 Z08 SPMG 05	63	5	8	32	31,5	120	45	0,861	TC058	T6	TGTC.	
TKÇ054	D50 A06 Z07 SPMG 06	50	6	7	32	31,5	120	45	0,833	TC059	T7		
TKÇ056	D63 A06 Z08 SPMG 06	63	6	8	32	31,5	120	45	0,850	TC059	T7	SPMG 06	
TKÇ058	D80 A06 Z10 SPMG 06	80	6	10	32	31,5	120	45	0,944	TC059	T7	TGTC.	
TKÇ060	D50 A08 Z06 SPMG 06	50	8	6	32	31,5	120	45	0,839	TC059	T7		
TKÇ062	D63 A08 Z08 SPMG 06	63	8	8	32	31,5	120	45	0,874	TC059	T7		
TKÇ064	D80 A08 Z10 SPMG 06	80	8	10	32	31,5	120	45	0,995	TC059	T7		
TKÇ066	D50 A10 Z06 SPMG 07	50	10	6	32	31,5	120	45	0,496	TC063	T8	SPMG 07	
TKÇ068	D63 A10 Z08 SPMG 07	63	10	8	32	31,5	120	45	0,868	TC063	T8	TGTC.	
TKÇ070	D80 A10 Z10 SPMG 07	80	10	10	32	31,5	120	45	0,994	TC063	T8		

Compatible with / Kompatible für (TGTC)

TCMT 1102 16T3

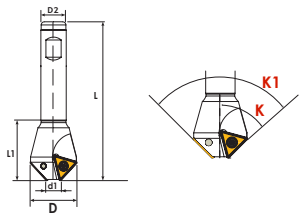
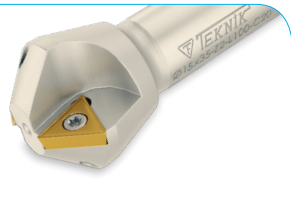

Order Code	Product Code	Dimensions (mm)									kg			
		K	K1	d1	D	Z	d2	L	L1					
S337	06-20 Z01 K30° TCMT 16	30°	60°	6	20	1	16	100	37	0,170	TC067	T15	TCMT 16T3	
S345	10-34 Z02 K30° TCMT 16	30°	60°	10	34	2	20	100	40	0,307	TC067	T15	TCMT 16T3	
S343	24-39 Z02 K30° TCMT 16	30°	60°	24	39	2	20	100	36	0,356	TC067	T15	TCMT 16T3	
S343-1	01-15,2 Z01 K45° TCMT 11	45°	90°	01	15,2	1	20	95,5	25	0,141	TC060	T8	TCMT 1102	
S334	04-16 Z01 K45° TCMT 11	45°	90°	4	16	1	16	100	35	0,140	TC060	T8	TCMT 1102	
S341	06-24 Z01 K45° TCMT 16	45°	90°	6	24	1	20	100	30	0,256	TC067	T15	TCMT 16T3	
S336	10-31 Z02 K45° TCMT 16	45°	90°	10	31	2	16	100	35	0,204	TC067	T15	TCMT 16T3	
S338	14-35 Z02 K45° TCMT 16	45°	90°	14	35	2	20	100	35	0,324	TC067	T15	TCMT 16T3	
S340	22-43 Z03 K45° TCMT 16	45°	90°	22	43	3	25	100	37	0,634	TC067	T15	TCMT 16T3	
S342	32-53 Z03 K45° TCMT 16	45°	90°	32	53	3	25	100	37	0,634	TC067	T15	TCMT 16T3	
S335	02-18 Z01 K60° TCMT 11	60°	120°	2	18	1	16	100	35	0,157	TC060	T8	TCMT 1102	
S339	10-31 Z02 K60° TCMT 16	60°	120°	10	31	2	16	100	35	0,213	TC067	T15	TCMT 16T3	

Angled Chamfering Mill

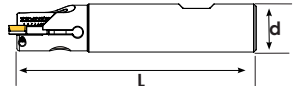

Order Code	Product Code	Dimensions (mm)					kg					
		D min	D max	d	L	Y°						
AH10	D20 R1 L100 TCMT 11	5	27	20	100	10-80	0,241	AH20 TCMT 11	TC063	M5x12	T8	TCMT 1102 ISO.
AH15	D25 R1 L100 TCMT 16	5	34	25	100	10-80	0,370	AH21 TCMT 16	TC067	M6x15	T15	TCMT 16T3 ISO.

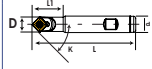

Order Code	Product Code	Dimensions (mm)							TC	ISO	Material
		K	D	Z	L	d	L1	kg			
S769	D16 d16 Z01 L100 SOMT 11	45°	16	1	100	16	32	0,153	TC067	T15	SOMT 11T3
S770	D16 d16 Z01 L150 SOMT 11	45°	16	1	150	16	32	0,238	M3,5x8,5		PLBT

*Compatible with / Kompatible für (PLBT)*

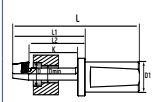

Order Code	Product Code	Dimensions (mm)							TC	ISO	Material	
		D	Dmin	K	L	L1	L2	D1				kg
C100	D18 K40 CCMT 06	18	10	40	47	60	110	20	0,194	TC060	T8	CCMT 060204
C102	D20 K45 CCMT 06	20	12	45	52	67	117	20	0,210	TC060	T8	ISO.
C104	D26 K60 CCMT 06	26	17	60	67	82	132	20	0,261	TC060	T8	
C106	D33 K75 CCMT 09	33	21	75	82	102	152	20	0,308	TC067	T15	CCMT 090304 ISO.

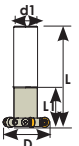

Order Code	Product Code	Dimensions (mm)					TC	ISO	Material		
		D	Z	L	d	L1				kg	
TKÇ200	D40 d20 Z04 L100 RHKW 10	40	4	100	20	40	0,285	TC074	TC040	T15	RHKW 1003
TKÇ202	D50 d25 Z05 L120 RHKW 10	50	5	120	25	40	0,284	TC074	TC040	T15	INGRSL.

*Compatible with / Kompatible für (INGRSL)*

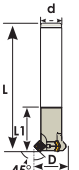

Order Code	Product Code	Dimensions (mm)					TC	ISO	Material	
		D	Z	L	d	L1				kg
S060	D32 d25 Z02 L150 SPMT 09	32	2	150	25	30	0,589	TC067	T15	SPMG 0904
S062	D40 d25 Z03 L150 SPMT 09	40	3	150	25	50	0,562	TC067	T15	TGTC.

*Compatible with. / Kompatible für (TGTC)*

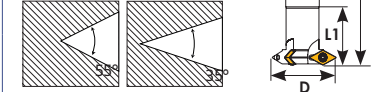
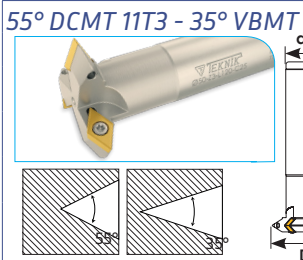

Order Code	Product Code	Dimensions (mm)					TC	ISO	Material	
		D	Z	L	d	L1				kg
S070	D50 d25 Z03 L120 DCMT 11	50	3	120	25	40	0,584	TC067	T15	DCMT 11T3 ISO.
S072	D63 d25 Z04 L120 DCMT 11	63	4	120	25	40	0,536	TC067	T15	
S073	D75 d25 Z03 L130 VBMT 16	75	3	130	25	40	0,924	TC074	T15	VBMT 1604 ISO.

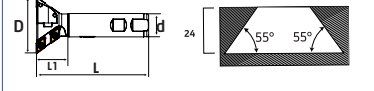

Order Code	Product Code	Dimensions (mm)					TC	ISO	Material	
		D	Z	L	d	L1				kg
TKÇ251	D60 d25 Z04 L120 DCMT 11	60	4	120	25	35	0,583	TC067	T15	DCMT 11T3 ISO.

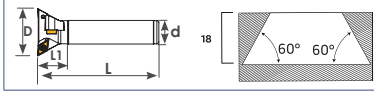

Order Code	Product Code	Dimensions (mm)					TC	ISO	Material	
		D	Z	L	d	L1				kg
TKÇ250	D50 d25 Z04 L120 DCMT 11	50	4	120	25	30	0,521	TC067	T15	DCMT 11T3 ISO.

Technical Solution for quality

# ANGLED CHAMFERING MILL

Chamfering end  
Milling

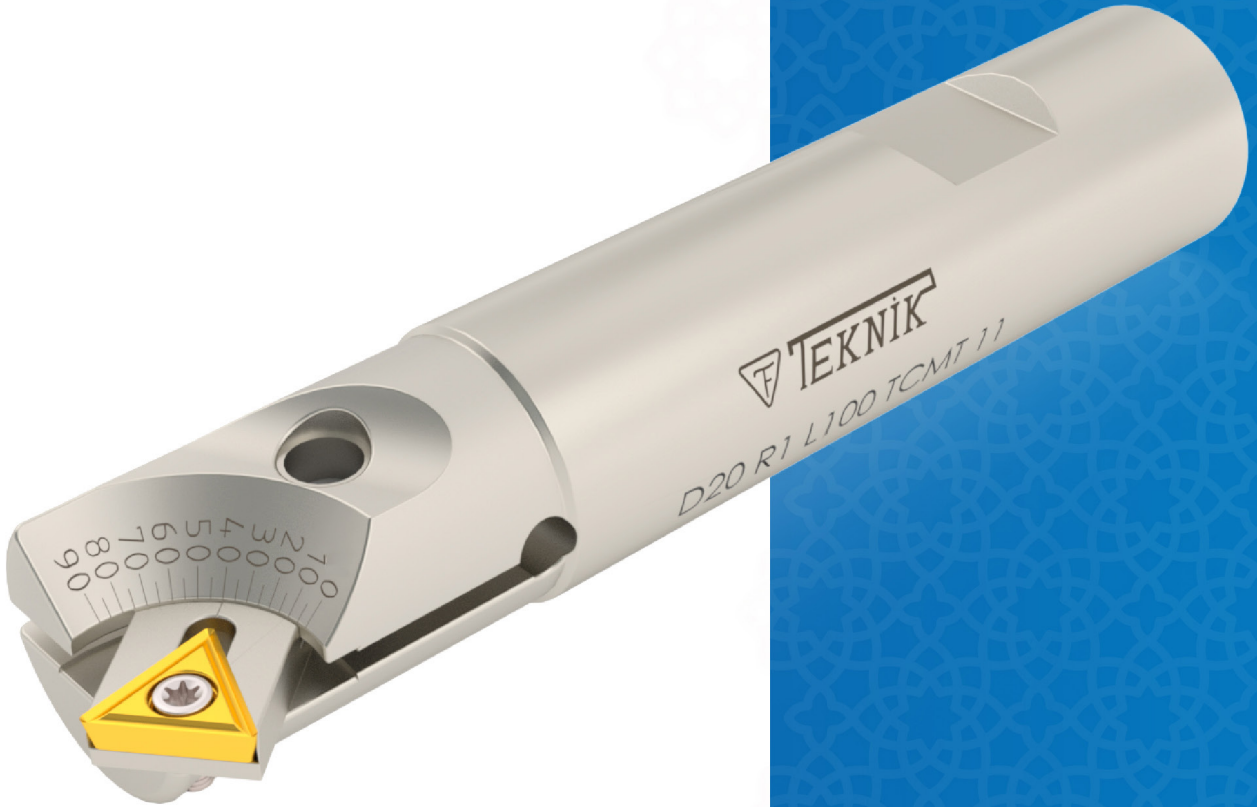

Derecesi ayarlanabilir havşa freze  
Adjustable angle chamfering mill

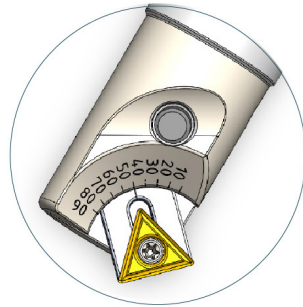

 **TEKNIK**  
Cutting Tools

[teknikcuttingtools.com](http://teknikcuttingtools.com) | +90 332 345 08 45

## Threading Holders



[www.teknikcuttingtools.com](http://www.teknikcuttingtools.com)



Kalite için TEKNİK çözüm  
Technical solution for quality

58-62



## External Threading Holder/R

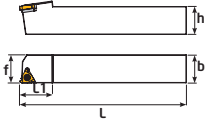
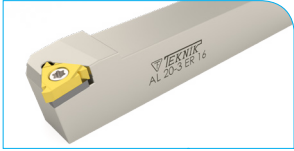

Order Code	Product Code	Dimensions (mm)						kg					
		h	b	f	L	L1	kg						
D261	ER 1212 J16- ER16	12	12	16	110	20	0,140	TC068	TA040	TC048	T15		
D259	ER 1616 H16- ER16	16	16	16	100	22	0,250	TC068	TA040	TC048	T15	16 ER	
D258	ER 2020 K16- ER16	20	20	20	125	25	0,410	TC068	TA040	TC048	T15		
D260	ER 2525 M16- ER16	25	25	25	150	30	0,750	TC068	TA040	TC048	T15		
D262	ER 3232 P16- ER16	32	32	32	170	30	1,430	TC068	TA040	TC048	T15		
D265	ER 2020 K22- ER22	20	20	20	125	30	0,458	TC078	--	--	T15	22 ER	
D266	ER 2525 M22- ER22	25	25	25	150	30	0,740	TC078	--	--	T15		

## External Threading Holder/L

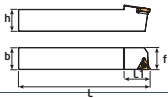

Order Code	Product Code	Dimensions (mm)						kg					
		h	b	f	L	L1	kg						
D268	EL 2020 K16 - L IR16	20	20	20	125	25	0,410	TC068	TA040	TC048	T15		
D269	EL 2525 M16 - L IR16	25	25	25	150	30	0,754	TC068	TA040	TC048	T15	16 IR	
D266-1	EL 2525 M22 - L IR22	25	25	25	150	30	0,748	TC078	--	--	T15	22 IR	

## Internal Threading Holder/R

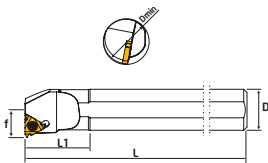
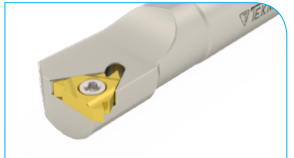

Order Code	Product Code	Dimensions (mm)					Hole Diameter	kg			
		D	L	L1	f	Dmin					
K348	SIR S10J- IR11	10	110	20	6	12	0,079	TC060	T8		
K350	SIR S12K- IR11	12	125	25	7,2	14	0,117	TC060	T8	11 IR	
K352	SIR S16Q- IR16	16	180	40	11	20	0,286	TC067	T10		
K354	SIR S20Q- IR16	20	180	40	13	25	0,436	TC067	T10	16 IR	
K356	SIR S25R- IR16	25	200	40	16	29	0,762	TC067	T10		
K358	SIR S32T- IR16	32	300	60	19,5	36	1,829	TC067	T10		
K358-1	SIR S20Q- IR22	20	180	40	14	24	0,431	TC078	T15		
K359	SIR S25R- IR22	25	200	40	17	32	0,757	TC078	T15	22 IR	
K360	SIR S32T- IR22	32	300	60	19,5	36	1,818	TC078	T15		
K360-1	SIR S40T- IR22	40	300	60	24,5	45	2,831	TC078	T15		

## Internal Threading Holder/L

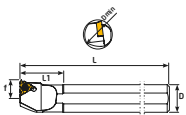
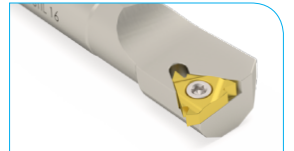

Order Code	Product Code	Dimensions (mm)					Hole Diameter	kg			
		D	L	L1	f	Dmin					
K360-2	SIL S10J-ER11	10	110	20	6	12	0,079	TC060	T8	11 ER	
K361	SIL S16Q-ER16	16	180	40	11	20	0,286	TC067	T10		
K362	SIL S20Q-ER16	20	180	40	13	25	0,436	TC067	T10	16 ER	
K363	SIL S25R-ER16	25	200	40	16	29	0,762	TC067	T10		

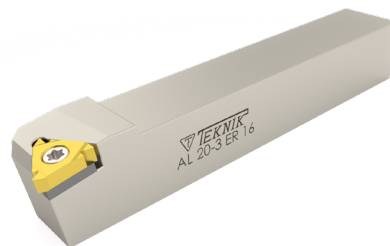
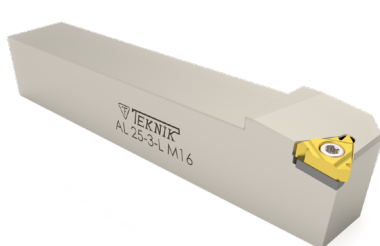

External Threading Holder/R

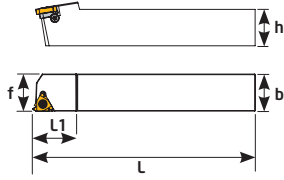
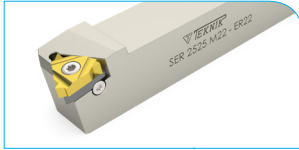

Order Code	Product Code	Dimensions (mm)						kg	TC	TA	BSP	TC	T	ER
		h	b	f	L	L1								
D494	AR 0808 H11 - ER11	8	8	11	100	20	0,061	TC060	--	--	--	T8		
D495	AR 1010 H11 - ER11	10	10	11	100	20	0,091	TC060	--	--	--	T8	11 ER	
D496	AR 1010 M11 - ER11	10	10	11	150	20	0,136	TC060	--	--	--	T8		
D497	AR 1212 K11 - ER11	12	12	12	125	20	0,160	TC060	--	--	--	T8		
D498	AR 1212 M11 - ER11	12	12	12	150	20	0,193	TC060	--	--	--	T8		
D500	AR 1212 J16 - ER16	12	12	16	110	22	0,110	TC068	TA061	BSP010	TC062	T15		
D501	AR 1616 H16 - ER16	16	16	16	100	25	0,220	TC068	TA061	BSP010	TC062	T15		
D502	AR 2020 K16 - ER16	20	20	20	125	30	0,410	TC068	TA061	BSP010	TC062	T15	16 ER	
D503	AR 2525 M16 - ER16	25	25	25	150	30	0,750	TC068	TA061	BSP010	TC062	T15		
D504	AR 3232 P16 - ER16	32	32	32	170	30	1,410	M3,5x11	TA061	BSP010	TC062	T15		
D505	AR 2525 M22 - ER22	25	25	25	150	30	0,740	TC077	TA062	BSP010	TC062	T15		
D506	AR 3232 P22 - ER22	32	32	32	170	30	1,430	TC077	TA062	BSP010	TC062	T15	22 ER	
D507	AR 4040 R22 - ER22	40	40	40	200	36	1,396	TC077	TA062	BSP010	TC062	T15		
D491	AR 2525 M27 - ER27	25	25	32	150	36	2,585	TC086	TA064	--	TC053	T20		
D492	AR 3232 P27 - ER27	32	32	32	170	40	0,791	TC086	TA064	--	TC053	T20	27 ER	
D493	AR 4040 R27 - ER27	40	40	40	200	40	1,405	TC086	TA064	--	TC053	T20		

External Threading Holder/L

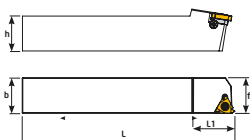

Order Code	Product Code	Dimensions (mm)						kg	TC	TA	BSP	TC	T	ER
		h	b	f	L	L1								
D508	AL 1212 J16 -L- IR16	12	12	16	110	22	0,119	TC068	TA060	BSP010	TC062	T15		
D509	AL 1616H16 -L- IR16	16	16	16	100	25	0,223	TC068	TA060	BSP010	TC062	T15		
D510	AL 2020 K16 -L- IR16	20	20	20	125	30	0,414	TC068	TA060	BSP010	TC062	T15	16 IR	
D511	AL 2525 M16 -L- IR16	25	25	25	150	30	0,753	TC068	TA060	BSP010	TC062	T15		
D512	AL 3232 P16 -L- IR16	32	32	32	170	30	1,417	TC068	TA060	BSP010	TC062	T15		
D513	AL 2525 M22 -L- IR22	25	25	25	150	30	0,749	TC077	TA063	BSP010	TC062	T15	22 IR	
D515	AL 3232 P22 -L- IR22	32	32	32	170	36	1,434	TC077	TA063	BSP010	TC062	T15		

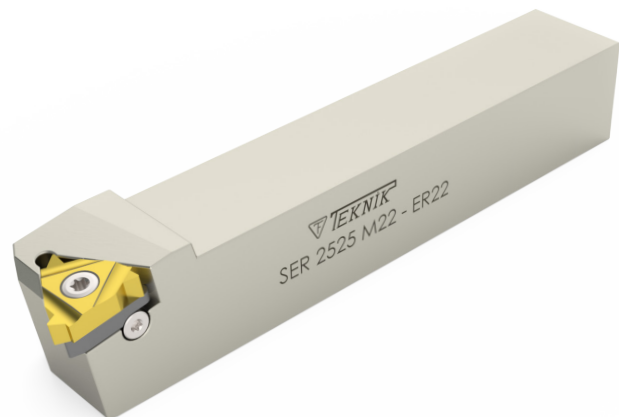
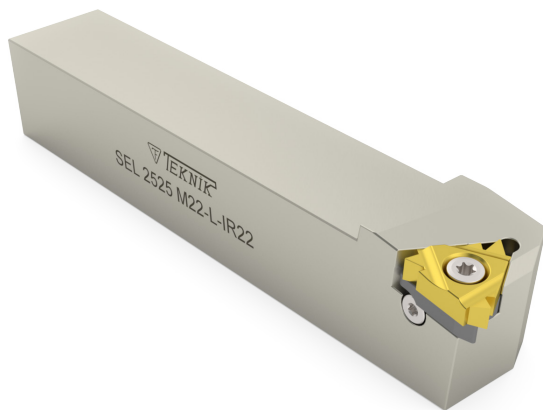

Internal Threading Holder/R

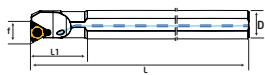
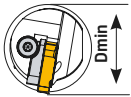
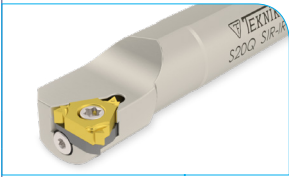

Order Code	Product Code	Dimensions (mm)					Hole Diameter	kg	Image 1	Image 2	Image 3	Image 4	Image 5	Image 6
		D	D1	L	L1	f								
K337-1	IR S12H - IR06	12	5,1	100	12	4,3	6	0,089	TC058	--	--	--	T6	6 IR
K337-2	IR S16K - IR08	16	6,6	125	18	5,3	7,8	0,195	TC058-1	--	--	--	T6	8 IR
K337-3	IR S10H - IR11	10	-	100	20	7,4	12	0,063	TC060	--	--	--	T8	
K337-4	IR S16K - IR11	16	10	125	25	7,4	12	0,167	TC060	--	--	--	T8	11 IR
K337-5	IR S16L - IR11	16	13	140	32	8,9	15	0,207	TC060	--	--	--	T8	
K337-6	IR S16M - IR16	16	13	150	32	10,2	16	0,221	TC067	--	--	--	T15	
K337-7	IR S20P - IR16	20	16	170	40	11,7	19	0,381	TC067	--	--	--	T15	
K338	IR S20Q - IR16	20	-	180	40	13,4	24	0,440	TC068	TA060	BSP010	TC062	T15	16 IR
K339	IR S25R - IR16	25	-	200	45	16,2	29	0,760	TC068	TA060	BSP010	TC062	T15	
K340	IR S32T - IR16	32	-	300	60	19,7	39	1,830	TC068	TA060	BSP010	TC062	T15	
K341	IR S40T - IR16	40	-	300	60	23,7	45	2,830	TC068	TA060	BSP010	TC062	T15	
K342	IR S50U - IR16	50	-	350	75	28,7	54	5,337	TC068	TA060	BSP010	TC062	T15	
K342-1	IR S20P - IR22	20	-	170	40	15,6	24	0,433	TC078	--	--	--	T15	
K343	IR S25R - IR22	25	-	200	45	18,1	30	0,760	TC077	TA063	BSP010	TC062	T15	
K344	IR S32T - IR22	32	-	300	40	21,6	39	1,820	TC077	TA063	BSP010	TC062	T15	22 IR
K345	IR S40T - IR22	40	-	300	60	25,6	46	2,840	TC077	TA063	BSP010	TC062	T15	
K346	IR S50U - IR22	50	-	350	75	30,6	56	5,335	TC077	TA063	BSP010	TC062	T15	
K347	IR S32S - IR27	32	-	250	60	22,6	40	1,523	TC086	TA065	--	TC053	T20	
K347-1	IR S40T - IR27	40	-	300	60	26,6	48	2,890	TC086	TA065	--	TC053	T20	27 IR
K347-2	IR S50U - IR27	50	-	350	75	31,6	58	5,177	TC086	TA065	--	TC053	T20	
K347-4	IR S60V - IR27	60	-	400	75	36,6	68	8,700	TC086	TA065	--	TC053	T20	

Internal Threading Holder/R with Coolant

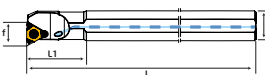

Order Code	Product Code	Dimensions (mm)					Hole Diameter	kg	Image 1	Image 2	Image 3	Image 4	Image 5	Image 6
		D	L	L1	f	Dmin								
K327-1	IR A16K - IR11	16	125	25	7,4	12	0,165	TC060	--	--	--	T8	11 IR	
K327-2	IR A16M - IR16	16	150	32	10,2	16	0,220	TC067	--	--	--	T8		
K327-3	IR A20P - IR16	20	170	40	11,7	19	0,380	TC067	--	--	--	T8		
K327-4	IR A20P - IR16	20	170	40	13,7	24	0,412	TC068	TA060	BSP10	TC062	T15	16 IR	
K327-5	IR A25R - IR16	25	200	45	16,2	29	0,710	TC068	TA060	BSP10	TC062	T15		
K327-6	IR A25R - IR22	25	200	45	18,1	29	0,730	TC077	TA063	BSP10	TC062	T15	22 IR	

Internal Threading Holder/L

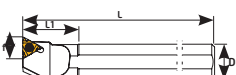
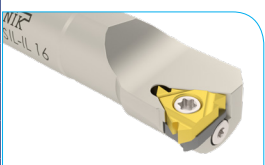

Order Code	Product Code	Dimensions (mm)					Hole Diameter	kg	Image 1	Image 2	Image 3	Image 4	Image 5	Image 6
		D	L	L1	f	Dmin								
K330	IL S20Q - ER16	20	180	40	13,4	24	0,440	TC068	TA061	BSP010	TC062	T15		
K331	IL S25R - ER16	25	200	45	16,2	29	0,760	TC068	TA061	BSP010	TC062	T15		
K332	IL S32T - ER16	32	300	60	19,7	39	1,830	TC068	TA061	BSP010	TC062	T15	16ER	
K333	IL S40T - ER16	40	300	60	23,7	45	2,830	TC068	TA061	BSP010	TC062	T15		
K334	IL S25R - ER22	25	200	45	18,1	30	0,760	TC077	TA062	BSP010	TC062	T15		
K335	IL S32T - ER22	32	300	40	21,6	39	1,820	TC077	TA062	BSP010	TC062	T15	22ER	
K336	IL S40T - ER22	40	300	60	24,5	50	2,840	TC077	TA062	BSP010	TC062	T15		

External Threading Holder

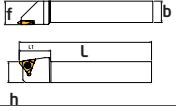

**NEW PRODUCT**

Order Code	Product Code	Dimensions (mm)						TC	T	VER
		L	L1	h	b	f	kg			
D520	AR 2020 VER 16	125	30	20	20	22	0,385	TC067	T15	VER16
D521	AR 2525 VER 16	150	30	25	25	27	0,705	TC067	T15	VER16
D522	AR 2525 VER 22	150	30	25	25	27,5	0,705	TC075	T15	VER22
D523	AR 3232 VER 27	170	-	32	32	36	1,215	TC075	T15	VER27

External Threading Holder

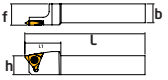

**NEW PRODUCT**

Order Code	Product Code	Dimensions (mm)						TC	T	VER
		L	L1	h	b	f	kg			
D524	AR 1616 S VER 16	100	30	16	16	18	0,185	TC067	T15	VER16
D525	AR 2020 S VER 16	125	30	20	20	22	0,360	TC067	T15	VER16
D526	AR 2525 S VER 16	150	30	25	25	27	0,675	TC067	T15	VER16

Internal Threading



**NEW PRODUCT**

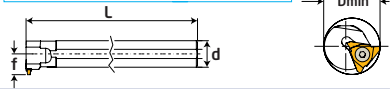

Order Code	Product Code	Dimensions (mm)					TC	T	VER
		Dmin	L	d	f	kg			
K345-5	IR S32T - VER 27	41	300	32	25	1,950	TC039	T20	VER27
K345-6	IR S40T - VER 27	49	300	40	25	3,110	TC039	T20	VER27

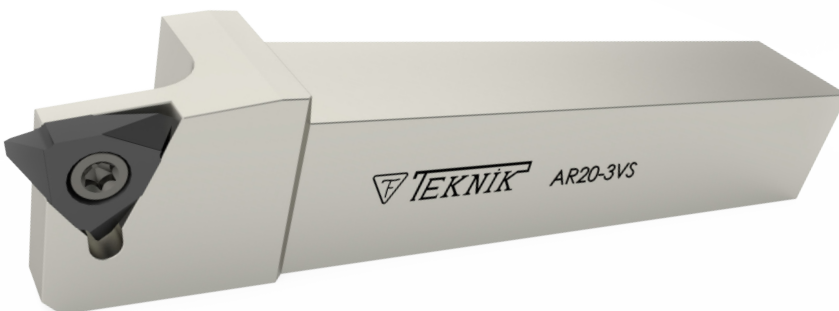

### Thread Cutting Tool With Coolant

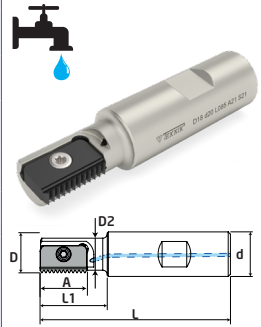

Order Code	Product Code	Dimensions (mm)									TC	T	S
		A	D	d	D2	L	L1	kg					
DC201	D9,5 d20 L085 A12 S12	12	9,5	20	7,5	85	14	0,195	TC092	T8	S12		
DC202	D9,9 d20 L085 A12 S12	12	9,9	20	7,6	85	16	0,191	TC092	T8	S12		
DC203	D12 d20 L075 A14 S14	14	12	20	8,9	75	20	0,156	TC096	T8	S14		
DC204	D14,5 d20 L085 A14 S14	14	14,5	20	11,2	85	25	0,179	TC096	T8	S14		
DC205	D17 d20 L085 A14 S14	14	17	20	13,4	85	30	0,180	TC096	T8	S14		
DC206	D18 d20 L085 A21 S21	21	18	20	14,4	85	30	0,176	TC074	T15	S21		
DC207	D21 d20 L094 A21 S21	21	21	20	16,5	94	40	0,204	TC074	T15	S21		
DC208	D29 d25 L110 A30 S30	30	29	25	22,4	110	50	0,390	TC256	T20	S30		
DC209	D48 d40 L153 A40 S40	40	48	40	35	153	78	1,325	TC086	T20	S40		

### Thread Cutting Tool With Coolant

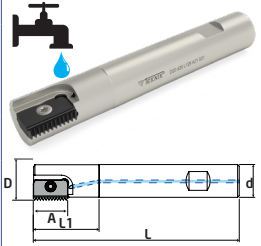

Order Code	Product Code	Dimensions (mm)						TC	T	S
		A	D	d	L	L1	kg			
DC210	D25 d20 L125 A21 S21	21	25	20	125	40	0,320	TC074	T15	S21
DC211	D31 d25 L150 A30 S30	30	31	25	150	60	0,597	TC256	T20	S30
DC212	D38 d32 L150 A30 S30	30	38	32	150	60	1,005	TC256	T20	S30
DC213	D48 d40 L210 A40 S40	40	48	40	210	78	2,068	TC086	T20	S40

### Thread Cutting Tool With Coolant

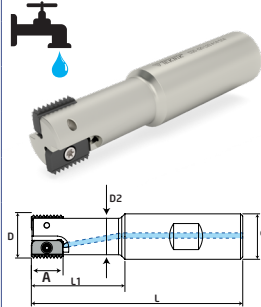

Order Code	Product Code	Dimensions (mm)									TC	T	S
		A	D	d	D2	L	L1	kg					
DC214	D20 d20 L093 A14 S14	14	20	20	16	93	41	0,202	TC093	T8	S14		
DC215	D30 d25 L108 A21 S21	21	30	25	24	108	52	0,401	TC074	T15	S21		
DC216	D40 d32 L130 A30 S30	30	40	32	30	130	70	0,781	TC256	T20	S30		
DC217	D50 d40 L153 A40 S40	40	50	40	38	153	78	1,455	TC086	T20	S40		



## P-S System Turning Holder With Coolant

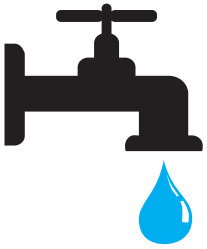
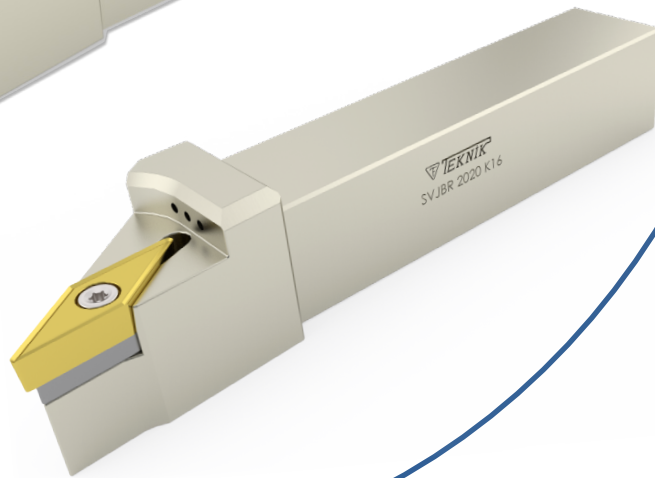
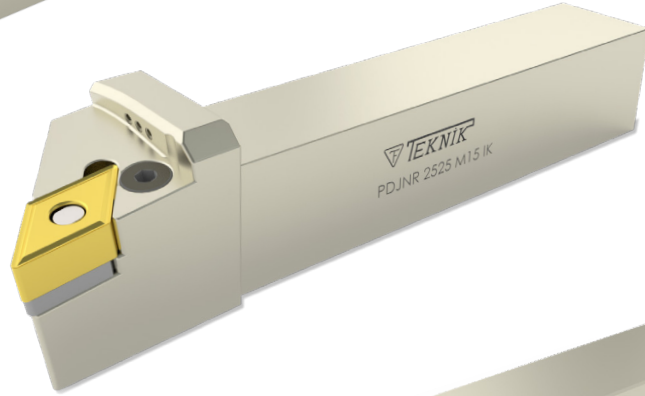
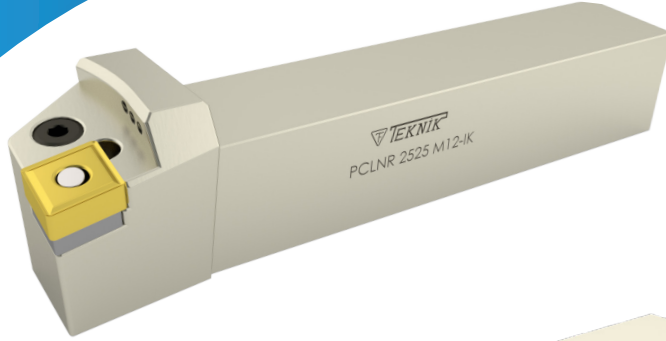

[www.teknikcuttingtools.com](http://www.teknikcuttingtools.com)



Kalite için TEKNİK çözüm

Technical solution for quality

64-68



93° PDJNR IC

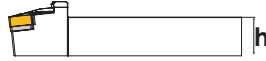
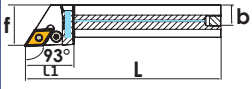
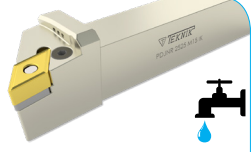

Order Code	Product Code	Dimensions (mm)											
		L	L1	h	b	f							
AP110	PDJNR 2020 K15-IKG1/8	125	30	20	20	25	0,409	TH821	TA014-1	TS-4	TL4B	3 Allen	DNMG 1506
AP112	PDJNR 2525 M15-IKG1/8	150	38	25	25	32	0,759	TH825	TA014-1	TS-4	TL4B	3 Allen	ISO.

93° PDJNL IC

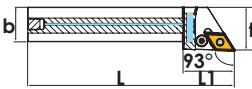

Order Code	Product Code	Dimensions (mm)											
		L	L1	h	b	f							
AP122	PDJNL 2020 K15-IKG1/8	125	40	20	20	25	0,409	TH821	TA014-1	TS-4	TL4B	3 Allen	DNMG 1506
AP124	PDJNL 2525 M15-IKG1/8	150	40	25	25	32	0,759	TH825	TA014-1	TS-4	TL4B	3 Allen	ISO.

95° PCLNR IC

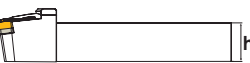
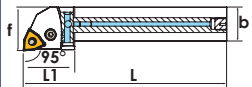

Order Code	Product Code	Dimensions (mm)											
		L	L1	h	b	f							
AP129	PCLNR 1616 H12-IKG1/8	100	28	16	16	20	0,236	TH818	TA016-1	TS4	TL4	3 Allen	CNMG 1204
AP130	PCLNR 2020 K12-IKG1/8	125	28	20	20	25	0,428	TH821	TA016-1	TS4	TL4	3 Allen	ISO.
AP132	PCLNR 2525 M12-IKG1/8	150	30	25	25	32	0,781	TH821	TA016-1	TS4	TL4	3 Allen	

95° PCLNL IC

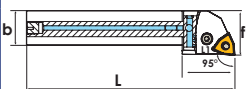
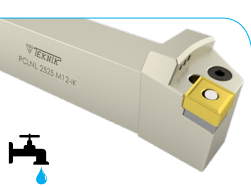

Order Code	Product Code	Dimensions (mm)											
		L	L1	h	b	f							
AP139	PCLNL 1616 H12-IKG1/8	100	28	16	16	20	0,236	TH818	TA016-1	TS4	TL4	3 Allen	
AP140	PCLNL 2020 K12-IKG1/8	125	28	20	20	25	0,428	TH821	TA016-1	TS4	TL4	3 Allen	CNMG 1204
AP142	PCLNL 2525 M12-IKG1/8	150	30	25	25	32	0,781	TH821	TA016-1	TS4	TL4	3 Allen	ISO.

95° PWLNR 08 IC

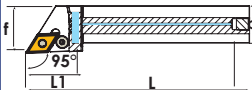
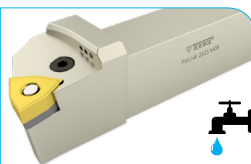

Order Code	Product Code	Dimensions (mm)											
		L	L1	h	b	f							
AP150	PWLNR 2020 K08-IKG1/8	125	30	20	20	25	0,425	TH821	TA020-1	TS4	TL4	3 Allen	WNMG 0804
AP151	PWLNR 2525 M08-IKG1/8	150	38	25	25	32	0,782	TH821	TA020-1	TS4	TL4	3 Allen	ISO.

95° PWLNL 08 IC

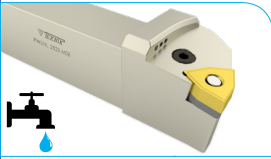

Order Code	Product Code	Dimensions (mm)						kg						
		L	L1	h	b	f	kg							
AP155	PWLNL 2020 K08-IKG1/8	125	30	20	20	25	0,425	TH821	TA020-1	TS4	TL4	3 Allen	WNMG 0804	
AP156	PWLNL 2525 M08-IKG1/8	150	38	25	25	32	0,782	TH821	TA020-1	TS4	TL4	3 Allen	ISO.	

95° PWLNR 06 IC

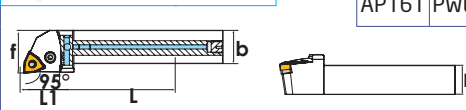

Order Code	Product Code	Dimensions (mm)						kg						
		L	L1	h	b	f	kg							
AP158	PWLNR 1616 H06-IKG1/8	100	30	16	16	20	0,218	TH617	TA021	TS3	TL3	2,5 Allen		
AP160	PWLNR 2020 K06-IKG1/8	125	30	20	20	25	0,415	TH617	TA021	TS3	TL3	2,5 Allen	WNMG 0604	
AP161	PWLNR 2525 M06-IKG1/8	150	30	25	25	32	0,756	TH617	TA021	TS3	TL3	2,5 Allen	ISO.	

95° PWLNL 06 IC



Order Code	Product Code	Dimensions (mm)						kg						
		L	L1	h	b	f	kg							
AP164	PWLNL 1616 H06-IKG1/8	100	30	16	16	20	0,218	TH617	TA021	TS3	TL3	2,5 Allen		
AP165	PWLNL 2020 K06-IKG1/8	125	30	20	20	25	0,415	TH617	TA021	TS3	TL3	2,5 Allen	WNMG 0604	
AP166	PWLNL 2525 M06-IKG1/8	150	30	25	25	32	0,756	TH617	TA021	TS3	TL3	2,5 Allen	ISO.	

95° SCLCR IC

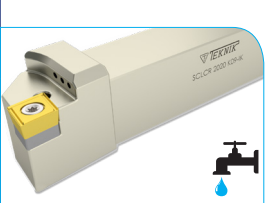

Order Code	Product Code	Dimensions (mm)						kg						
		L	L1	h	b	f	kg							
AP500	SCLCR 1616 H09-IK	100	25	16	16	20	0,205	TC068	TA015	TC048	T15		CCMT 0903	
AP501	SCLCR 2020 K09-IK	125	25	20	20	25	0,418	TC068	TA015	TC048	T15		ISO.	
AP502	SCLCR 2020 K12-IK	125	30	20	20	25	0,370	TC075	TA15-1	TC049-1	T15		CCMT 1204	
AP503	SCLCR 2525 M12-IK	150	30	25	25	32	0,771	TC075	TA15-1	TC049-1	T15			

95° SCLCL IC

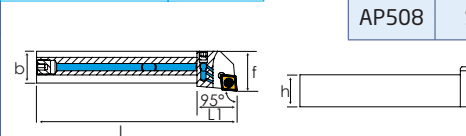
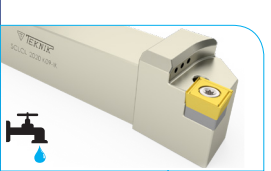

Order Code	Product Code	Dimensions (mm)						kg						
		L	L1	h	b	f	kg							
AP505	SCLCL 1616 H09-IK	100	25	16	16	20	0,205	TC068	TA015	TC048	T15		CCMT 0903	
AP506	SCLCL 2020 K09-IK	125	25	20	20	25	0,418	TC068	TA015	TC048	T15		ISO.	
AP507	SCLCL 2020 K12-IK	125	30	20	20	25	0,375	TC075	TA15-1	TC049-1	T15		CCMT 1204	
AP508	SCLCL 2525 M12-IK	150	30	25	25	32	0,771	TC075	TA15-1	TC049-1	T15			

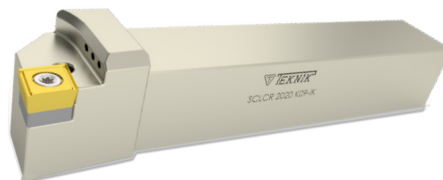

93° SDJCR IC

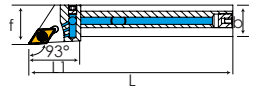
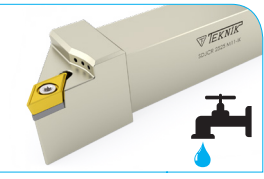

Order Code	Product Code	Dimensions (mm)						kg					
		L	L1	h	f	b							
AP509	SDJCR 1212 J11-1K	110	32	12	16	12	0,107	TC068	TA030	TC048	T8	DCMT 11T3	
AP510	SDJCR 1616 H11-1K	100	32	16	20	16	0,204	TC068	TA030	TC048	T8	ISO.	
AP511	SDJCR 2020 K11-1K	125	32	20	25	20	0,404	TC068	TA030	TC048	T8		
AP512	SDJCR 2525 M11-1K	150	35	25	32	25	0,735	TC068	TA030	TC048	T8		

93° SDJCL IC

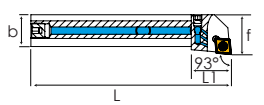

Order Code	Product Code	Dimensions (mm)						kg					
		L	L1	h	f	b							
AP514	SDJCL 1212 J11-1K	110	32	12	16	12	0,107	TC068	TA030	TC048	T8	DCMT 11T3	
AP515	SDJCL 1616 H11-1K	100	32	16	16	16	0,204	TC068	TA030	TC048	T8	ISO.	
AP516	SDJCL 2020 K11-1K	125	32	20	25	20	0,404	TC068	TA030	TC048	T8		
AP517	SDJCL 2525 M11-1K	150	35	25	32	25	0,735	TC068	TA030	TC048	T8		

93° SDJCR IC

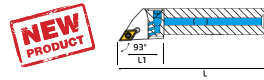

**NEW PRODUCT**

Order Code	Product Code	Dimensions (mm)						kg			
		L	L1	h	b	f					
AP560	SDJCR 1212 K07-1C	125	27	12	12	16	0,175	TC060	T8		
AP561	SDJCR 1616 H07-1C	100	27	16	16	20	0,210	TC060	T8	DCMT 0702	
AP562	SDJCR 2020 K07-1C	125	27	20	20	25	0,400	TC060	T8	ISO.	

93° SDJCL IC

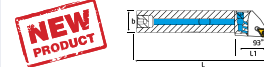
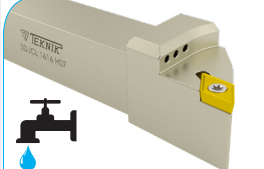

**NEW PRODUCT**

Order Code	Product Code	Dimensions (mm)						kg			
		L	L1	h	f	b					
AP565	SDJCL 1212 K07-1C	125	27	12	16	12	0,175	TC060	T8		
AP566	SDJCL 1616 H07-1C	100	27	16	20	16	0,210	TC060	T8	DCMT 0702	
AP567	SDJCL 2020 K07-1C	125	27	20	25	20	0,400	TC060	T8	ISO.	

93° SDJCR -F IC

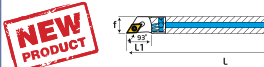

**NEW PRODUCT**

Order Code	Product Code	Dimensions (mm)						kg						
		L	L1	h	f	b								
AP569	SDJCR 1212 K07-F-1C	125	27	12	12	12	0,175	TC060	---	---	T8	ISO.		
AP570	SDJCR 1616 H07-F-1C	100	27	16	16	16	0,210	TC060	---	---	T8	DCMT 0702		
AP571	SDJCR 1212 J11-F-1C	110	32	12	12	12	0,106	TC067	TA030	TC048	T15	DCMT 11T3		
AP572	SDJCR 1616 H11-F-1C	100	32	16	16	16	0,167	TC067	TA030	TC048	T15			

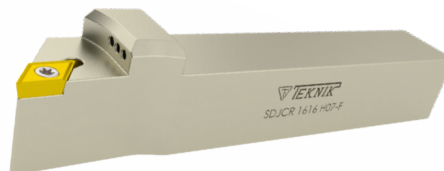



Order Code	Product Code	Dimensions (mm)						kg					
		L	L1	h	f	b							
AP573	SDJCL 1212 K07 F-IC	125	27	12	12	12	0,175	TC060	---	---	T8	ISO.	
AP574	SDJCL 1616 H07 F-IC	100	27	16	16	16	0,210	TC060	---	---	T8	DCMT 0702	
AP575	SDJCL 1212 J11-F-IC	110	32	12	12	12	0,106	TC067	TA030	TC048	T15	DCMT 11T3	

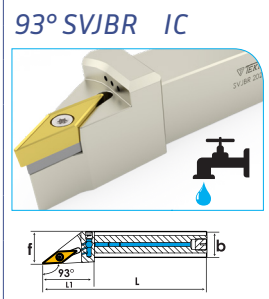

Order Code	Product Code	Dimensions (mm)						kg					
		L	L1	h	f	b							
AP540	SVJBR 1010 J11-1K	110	30	10	12	10	0,097	TC061	---	---	T8	VBMT 1103	
AP541	SVJBR 1212 J11-1K	110	32	12	16	12	0,141	TC061	---	---	T8	ISO.	
AP545	SVJBR 2020 K16-1K	125	40	20	25	20	0,192	TC068	TA034	TC048	T15	VBMT 1604	
AP546	SVJBR 2525 M16-1K	150	40	25	32	25	0,192	TC068	TA034	TC048	T15	ISO.	

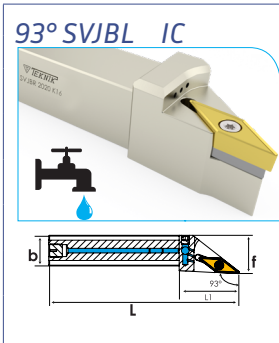

Order Code	Product Code	Dimensions (mm)						kg					
		L	L1	h	f	b							
AP550	SVJBL 1010 J11-1K	110	30	10	12	10	0,097	TC061	---	---	T8	VBMT 1103	
AP551	SVJBL 1212 J11-1K	110	32	12	16	12	0,141	TC061	---	---	T8	ISO.	
AP552	SVJBL 1616 H11-1K	100	35	16	20	16	0,167	TC061	---	---	T8		
AP555	SVJBL 2020 K16-1K	125	40	20	25	20	0,192	TC068	TA034	TC048	T15	VBMT 1604	
AP556	SVJBL 2525 M16-1K	150	40	25	32	25	0,192	TC068	TA034	TC048	T15	ISO.	

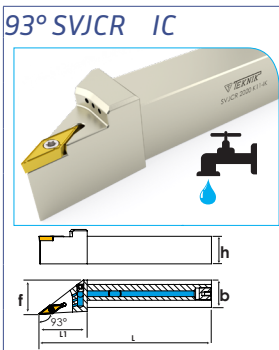

Order Code	Product Code	Dimensions (mm)						kg					
		L	L1	h	f	b							
AP519	SVJCR 1212 J11-1K	110	32	12	16	12	0,109	TC061	---	---	T8	VCMT 1103	
AP520	SVJCR 1616 H11-1K	100	25	16	20	16	0,204	TC061	---	---	T8	ISO.	
AP521	SVJCR 2020 K11-1K	125	33	20	25	20	0,378	TC061	---	---	T8		
AP522	SVJCR 2525 M11-1K	150	40	25	32	25	0,690	TC061	---	---	T8		
AP525	SVJCR 2020 K16-1K	125	33	20	25	20	0,385	TC068	TA034	TC048	T15	VCMT 1604	
AP526	SVJCR 2525 M16-1K	150	40	25	32	25	0,683	TC068	TA034	TC048	T15	ISO.	

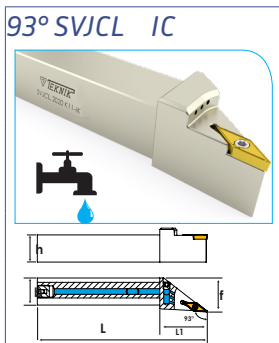

Order Code	Product Code	Dimensions (mm)						kg					
		L	L1	h	f	b							
AP529	SVJCL 1212 J11-1K	110	32	12	16	12	0,109	TC061	---	---	T8	VCMT 1103	
AP530	SVJCL 1616 H11-1K	100	25	16	20	16	0,204	TC061	---	---	T8	ISO.	
AP531	SVJCL 2020 K11-1K	125	33	20	25	20	0,378	TC061	---	---	T8		
AP532	SVJCL 2525 M11-1K	150	40	25	32	25	0,627	TC061	---	---	T8		
AP535	SVJCL 2020 K16-1K	125	33	20	25	20	0,385	TC068	TA034	TC048	T15	VCMT 1604	
AP536	SVJCL 2525 M16-1K	150	40	25	32	25	0,683	TC068	TA034	TC048	T15	ISO.	

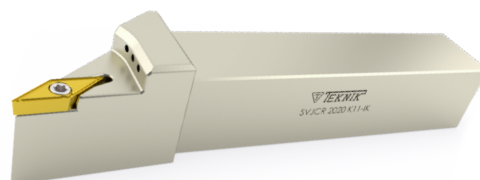

93° SVJBR-F IC

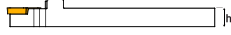
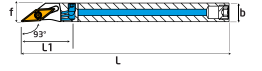
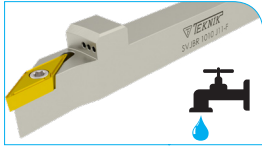

Order Code	Product Code	Dimensions (mm)						kg	TC061	T8	VBMT 1103
		h	b	f	L	L1					
AP547	SVJBR 1010 J11-F-İK	10	10	10	110	30	0,72	TC061	T8	VBMT 1103	
AP548	SVJBR 1212 J11-F-İK	12	12	12	110	32	0,105	TC061	T8	ISO.	
AP549	SVJBR 1616 H11-F-İK	16	16	16	100	35	0,160	TC061	T8		

93° SVJBL-F IC

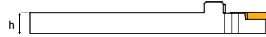
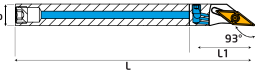
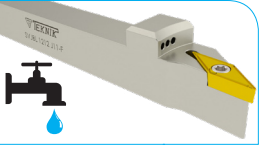

Order Code	Product Code	Dimensions (mm)						kg	TC061	T8	VBMT 1103
		L	L1	h	f	b					
AP557	SVJBL 1010 J11-F-İK	110	30	10	10	10	0,72	TC061	T8	VBMT 1103	
AP558	SVJBL 1212 J11-F-İK	110	32	12	12	12	0,105	TC061	T8	ISO.	

93° SVJCR-F IC

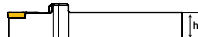
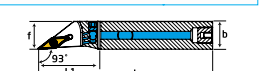

Order Code	Product Code	Dimensions (mm)						kg	TC061	T8	VCMT 1103
		L	L1	h	f	b					
AP527	SVJCR 1212 J11-F-İK	110	32	12	12	12	0,102	TC061	T8	VCMT 1103	
AP528	SVJCR 1616 H11-F-İK	100	35	16	16	16	0,185	TC061	T8	ISO.	

93° SVJCL-F IC

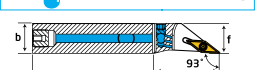

Order Code	Product Code	Dimensions (mm)						kg	TC061	T8	VCMT 1103
		L	L1	h	f	b					
AP537	SVJCL 1212 J11-F-İK	110	32	12	12	12	0,102	TC061	T8	VCMT 1103	
AP538	SVJCL 1616 H11-F-İK	100	35	16	16	16	0,185	TC061	T8	ISO.	

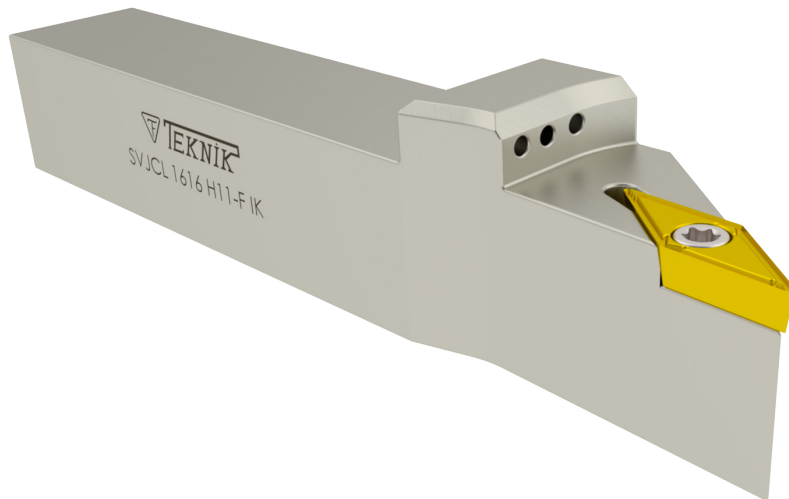

## P System External Turning Holder



[www.teknikcuttingtools.com](http://www.teknikcuttingtools.com)



Kalite için **TEKNIK** çözüm  
Technical solution for quality

70-71



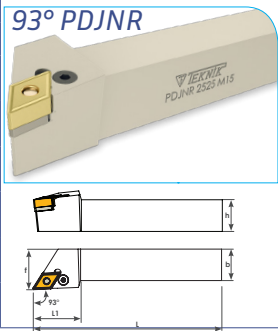

Order Code	Product Code	Dimensions (mm)						kg						
		L	L1	h	f	b								
P107	PDJNR 1616 H11	100	25	16	25	16	0,242	TH613	TA013	TS-3	TL3	2,5 Allen	DNMG 1104	
P108	PDJNR 2020 K11	125	30	20	25	20	0,435	TH617	TA013	TS-3	TL3	2,5 Allen	ISO.	
P109	PDJNR 2525 M11	150	30	25	32	25	0,767	TH617	TA013	TS-3	TL3	2,5 Allen		
P110	PDJNR 2020 K15	125	35	20	25	20	0,402	TH821	TA014-1	TS-4	TL4B	3 Allen		
P112	PDJNR 2525 M15	150	38	25	32	25	0,730	TH825	TA014-1	TS-4	TL4B	3 Allen	DNMG 1506	
P114	PDJNR 3232 P15	170	38	32	40	32	1,384	TH825	TA014-1	TS-4	TL4B	3 Allen	ISO.	

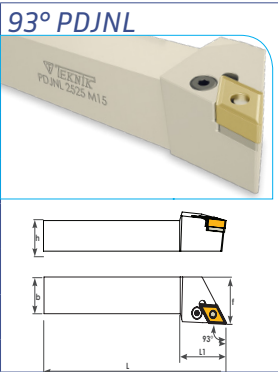

Order Code	Product Code	Dimensions (mm)						kg						
		L	L1	h	f	b								
P119	PDJNL 1616 H11	100	25	16	25	16	0,242	TH613	TA013	TS-3	TL3	2,5 Allen	DNMG 1104	
P120	PDJNL 2020 K11	125	30	20	25	20	0,435	TH617	TA013	TS-3	TL3	2,5 Allen	ISO.	
P121	PDJNL 2525 M11	150	30	25	32	25	0,767	TH617	TA013	TS-3	TL3	2,5 Allen		
P122	PDJNL 2020 K15	125	35	20	25	20	0,402	TH821	TA014-1	TS-4	TL4B	3 Allen		
P124	PDJNL 2525 M15	150	38	25	32	25	0,730	TH825	TA014-1	TS-4	TL4B	3 Allen	DNMG 1506	
P126	PDJNL 3232 P15	170	38	32	40	32	1,384	TH825	TA014-1	TS-4	TL4B	3 Allen	ISO.	

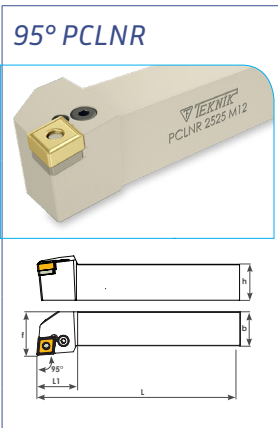

Order Code	Product Code	Dimensions (mm)						kg						
		L	L1	h	f	b								
P126-1	PCLNR 1616 H09	100	20	16	20	16	0,231	TH617	TA023	TS3	TL3	2,5 Allen	CNMG 09T3	
P127	PCLNR 2020 K09	125	22	20	25	20	0,428	TH617	TA023	TS3	TL3	2,5 Allen	ISO.	
P128	PCLNR 2525 M09	150	22	25	32	25	0,785	TH617	TA023	TS3	TL3	2,5 Allen		
P129	PCLNR 1616 H12	100	30	16	20	16	0,225	TH818	TA016-1	TS4	TL4	3 Allen		
P130	PCLNR 2020 K12	125	30	20	25	20	0,421	TH821	TA016-1	TS4	TL4	3 Allen	CNMG 1204	
P132	PCLNR 2525 M12	150	30	25	32	25	0,766	TH821	TA016-1	TS4	TL4	3 Allen	ISO.	
P134	PCLNR 3232 P12	170	30	32	40	32	1,429	TH821	TA016-1	TS4	TL4	3 Allen		

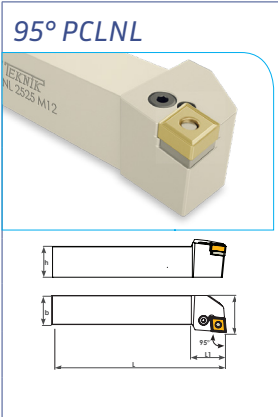

Order Code	Product Code	Dimensions (mm)						kg						
		L	L1	h	f	b								
P136	PCLNL 1616 H09	100	20	16	20	16	0,231	TH617	TA023	TS3	TL3	2,5 Allen	CNMG 09T3	
P137	PCLNL 2020 K09	125	22	20	25	20	0,428	TH617	TA023	TS3	TL3	2,5 Allen	ISO.	
P138	PCLNL 2525 M09	150	22	25	32	25	0,785	TH617	TA023	TS3	TL3	2,5 Allen		
P139	PCLNL 1616 H12	100	30	16	20	16	0,225	TH818	TA016-1	TS4	TL4	3 Allen		
P140	PCLNL 2020 K12	125	30	20	25	20	0,421	TH821	TA016-1	TS4	TL4	3 Allen	CNMG 1204	
P142	PCLNL 2525 M12	150	30	25	32	25	0,766	TH821	TA016-1	TS4	TL4	3 Allen	ISO.	
P144	PCLNL 3232 P12	170	30	32	40	32	1,429	TH821	TA016-1	TS4	TL4	3 Allen		

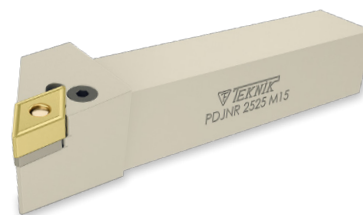
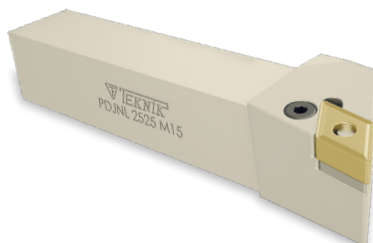

95° PWLNR 08	Order Code	Product Code	Dimensions (mm)											
			L	L1	h	f	b							
	P150	PWLNR 2020 K08	125	30	20	25	20	0,430	TH821	TA020-1	TS4	TL4	3 Allen	
	P151	PWLNR 2525 M08	150	38	25	32	25	0,773	TH821	TA020-1	TS4	TL4	3 Allen	WNMG 0804
	P152	PWLNR 3232 P08	170	38	32	40	32	1,421	TH821	TA020-1	TS4	TL4	3 Allen	ISO.

95° PWLNL 08	Order Code	Product Code	Dimensions (mm)											
			L	L1	h	f	b							
	P155	PWLNL 2020 K08	125	30	20	25	20	0,430	TH821	TA020-1	TS4	TL4	3 Allen	
	P156	PWLNL 2525 M08	150	38	25	32	25	0,773	TH821	TA020-1	TS4	TL4	3 Allen	WNMG 0804
	P157	PWLNL 3232 P08	170	38	32	40	32	1,421	TH821	TA020-1	TS4	TL4	3 Allen	ISO.

95° PWLNR 06	Order Code	Product Code	Dimensions (mm)											
			L	L1	h	f	b							
	P158	PWLNR 1616 H06	100	30	16	20	16	0,223	TH617	TA021	TS3	TL3	2,5 Allen	
	P160	PWLNR 2020 K06	125	30	20	25	20	0,429	TH617	TA021	TS3	TL3	2,5 Allen	WNMG 0604
	P161	PWLNR 2525 M06	150	30	25	32	25	0,758	TH617	TA021	TS3	TL3	2,5 Allen	ISO.

95° PWLNL 06	Order Code	Product Code	Dimensions (mm)											
			L	L1	h	f	b							
	P164	PWLNL 1616 H06	100	30	16	20	16	0,223	TH617	TA021	TS3	TL3	2,5 Allen	
	P165	PWLNL 2020 K06	125	30	20	25	20	0,429	TH617	TA021	TS3	TL3	2,5 Allen	WNMG 0604
	P166	PWLNL 2525 M06	150	30	25	32	25	0,758	TH617	TA021	TS3	TL3	2,5 Allen	ISO.

45° PSSNR	Order Code	Product Code	Dimensions (mm)											
			L	L1	h	f	b							
	P170	PSSNR 1616 H12	100	30	16	20	16	0,218	TH818	TA050	TS4	TL4	3 Allen	
	P171	PSSNR 2020 K12	125	30	20	25	20	0,416	TH821	TA050	TS4	TL4	3 Allen	SNMG 1204
	P172	PSSNR 2525 M12	150	30	25	32	25	0,742	TH821	TA050	TS4	TL4	3 Allen	ISO.

45° PSSNL	Order Code	Product Code	Dimensions (mm)											
			L	L1	h	f	b							
	P180	PSSNL 1616 H12	100	30	16	20	16	0,218	TH818	TA050	TS4	TL4	3 Allen	
	P181	PSSNL 2020 K12	125	30	20	25	20	0,416	TH821	TA050	TS4	TL4	3 Allen	SNMG 1204
	P182	PSSNL 2525 M12	150	30	25	32	25	0,742	TH821	TA050	TS4	TL4	3 Allen	ISO.

**TEKNIK**

» ÇALIŞKAN »  
« TEKNOLOJİ «

[www.teknikcuttingtools.com](http://www.teknikcuttingtools.com)



## D-M-C System External Turning Holders

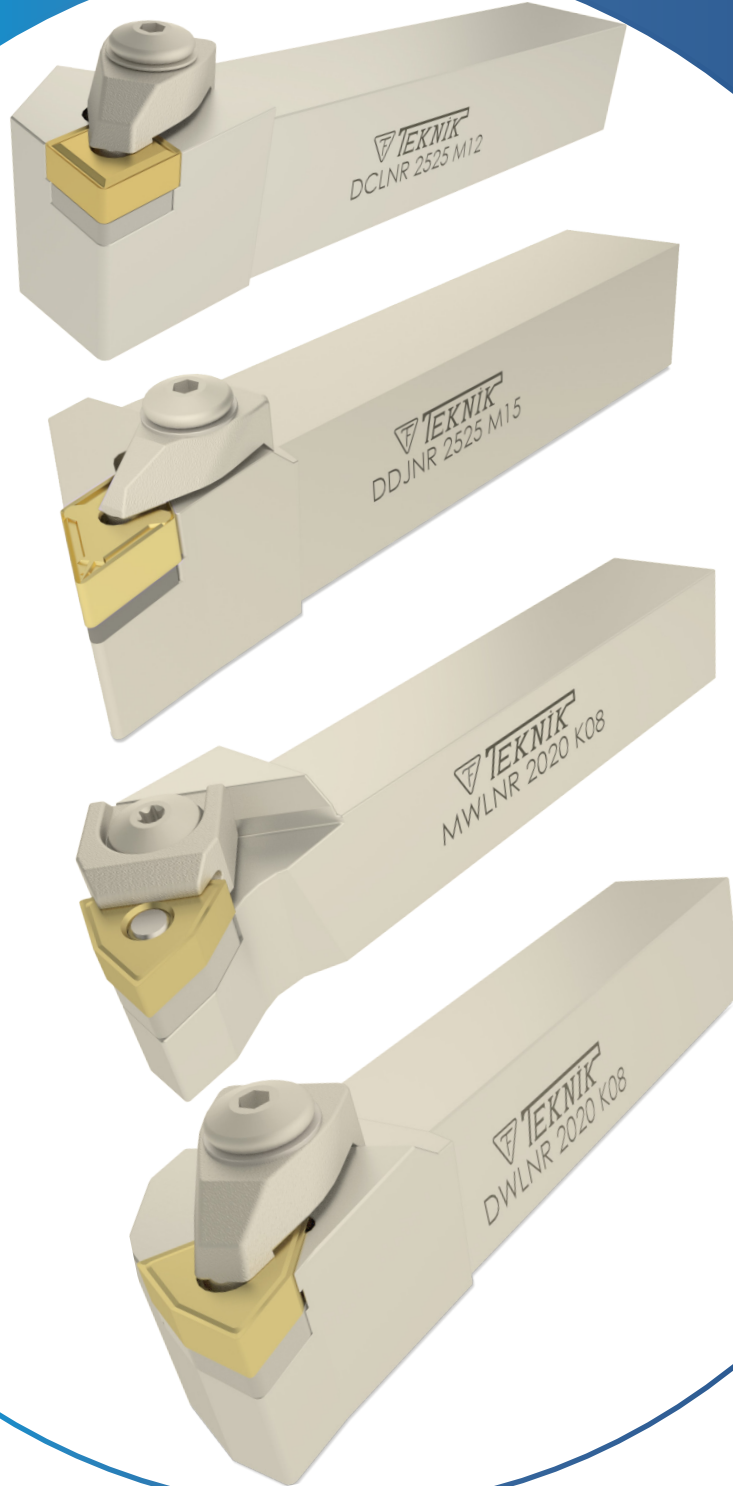

[www.teknikcuttingtools.com](http://www.teknikcuttingtools.com)



Kalite için TEKNİK çözüm

Technical solution for quality

74-78



93° DDJNR

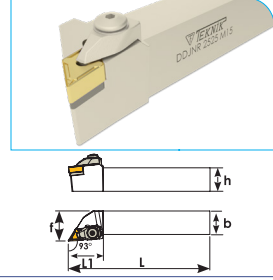

Order Code	Product Code	Dimensions (mm)													ISO
		L	L1	h	f	b									
D167	DDJNR 2020 K11	125	30	20	25	20	0,421	TC046	TA013	TC034	BK024	BY041	BSP031	3 Allen	DNMG 1104
D168	DDJNR 2525 M11	150	30	25	32	25	0,751	TC046	TA013	TC034	BK024	BY041	BSP031	3 Allen	ISO.
D170	DDJNR 2020 K15	125	35	20	25	20	0,425	TC044	TA014-1	TC038	BK020	BY040	BSP030	3 Allen	
D172	DDJNR 2525 M15	150	35	25	32	25	0,756	TC044	TA014-1	TC038	BK020	BY040	BSP030	3 Allen	DNMG 1506
D174	DDJNR 3232 P15	170	35	32	40	32	1,345	TC044	TA014-1	TC038	BK020	BY040	BSP030	3 Allen	ISO.

93° DDJNL

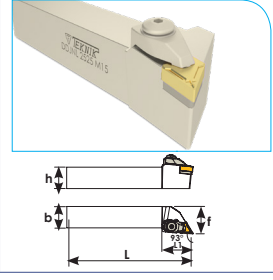

Order Code	Product Code	Dimensions (mm)													ISO
		L	L1	h	f	b									
D307-1	DDJNL 2020 K11	125	30	20	25	20	0,421	TC046	TA013	TC034	BK024	BY041	BSP031	3 Allen	DNMG 1104
D308	DDJNL 2525 M11	150	30	25	32	25	0,751	TC046	TA013	TC034	BK024	BY041	BSP031	3 Allen	ISO.
D310	DDJNL 2020 K15	125	35	20	25	20	0,425	TC044	TA014-1	TC038 M3x10	BK020	BY040	BSP030	3 Allen	
D312	DDJNL 2525 M15	150	35	25	32	25	0,756	TC044	TA014-1	TC038 M3x10	BK020	BY040	BSP030	3 Allen	DNMG 1506
D314	DDJNL 3232 P15	170	35	32	40	32	1,345	TC044	TA014-1	TC038 M3x10	BK020	BY040	BSP030	3 Allen	ISO.

93° DDJNR



Order Code	Product Code	Dimensions (mm)													ISO
		L	L1	h	f	b									
D171	DDJNR 2020 K15	125	38	20	25	20	0,426	TC044	TA014-1	TC038	BK020	BY040	BSP030	3 Allen	DNMG 1504
D169	DDJNR 2525 M15	150	38	25	32	25	0,763	TC044	TA014-1	TC038	BK020	BY040	BSP030	3 Allen	ISO.

93° DDJNL

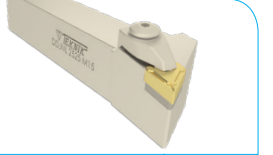

Order Code	Product Code	Dimensions (mm)													ISO
		L	L1	h	f	b									
D313	DDJNL 2020 K15	125	38	20	25	20	0,426	TC044	TA014-1	TC038	BK020	BY040	BSP030	3 Allen	DNMG 1504
D309	DDJNL 2525 M15	150	38	25	32	25	0,763	TC044	TA014-1	TC038	BK020	BY040	BSP030	3 Allen	ISO.

107,5° DDHNR

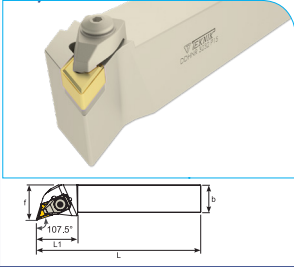

Order Code	Product Code	Dimensions (mm)													ISO
		L	L1	h	f	b									
D096	DDHNR 2020 K15	125	33	20	25	20	0,428	TC044	TA014-1	TC038	BK020	BY040	BSP030	3 Allen	
D097	DDHNR 2525 M15	150	33	25	32	25	0,753	TC044	TA014-1	TC038	BK020	BY040	BSP030	3 Allen	DNMG 1506
D098	DDHNR 3232 P15	170	33	32	40	32	1,290	TC044	TA014-1	TC038	BK020	BY040	BSP030	3 Allen	ISO.

107,5° DDHNL

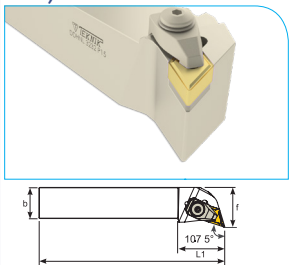

Order Code	Product Code	Dimensions (mm)													ISO
		L	L1	h	f	b									
D295	DDHNL 2020 K15	125	33	20	25	20	0,428	TC044	TA014-1	TC038	BK020	BY040	BSP030	3 Allen	
D296	DDHNL 2525 M15	150	33	25	32	25	0,753	TC044	TA014-1	TC038	BK020	BY040	BSP030	3 Allen	DNMG 1506
D297	DDHNL 3232 P15	170	33	32	40	32	1,290	TC044	TA014-1	TC038	BK020	BY040	BSP030	3 Allen	ISO.

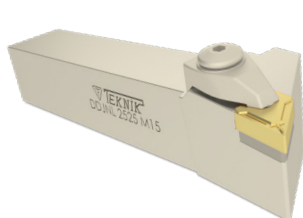

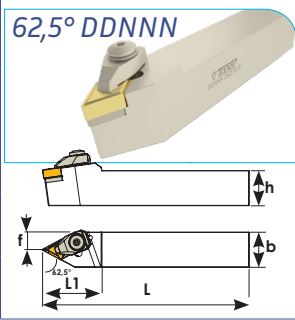

Order Code	Product Code	Dimensions (mm)													
		L	L1	h	f	b									
D103	DDNNN 2525 M11	150	38	25	25	25	0,700	TC046	TA030	TC075	BK024	BY041	BSP031	3 Allen	DNMG 1104
D104	DDNNN 2020 K15	125	40	20	10	20	0,404	TC044	TA014-1	TC038	BK020	BY040	BSP030	3 Allen	DNMG 1506
D106	DDNNN 2525 M15	150	40	25	12,5	25	0,724	TC044	TA014-1	TC038	BK020	BY040	BSP030	3 Allen	ISO.
D109	DDNNN 3232 P15	170	40	32	16	32	1,290	TC044	TA014-1	TC038	BK020	BY040	BSP030	3 Allen	

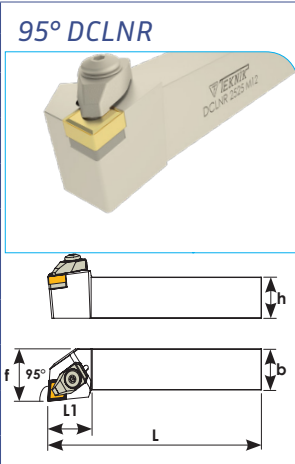

Order Code	Product Code	Dimensions (mm)													
		L	L1	h	f	b									
D160	DCLNR 2020 K12	125	30	20	25	20	0,441	TC044	TA016-1	TC038	BK020	BY040	BSP030	3 Allen	CNMG
D162	DCLNR 2525 M12	150	30	25	32	25	0,785	TC044	TA016-1	TC038	BK020	BY040	BSP030	3 Allen	1204
D164	DCLNR 3232 P12	170	30	32	40	32	1,379	TC044	TA016-1	TC038	BK020	BY040	BSP030	3 Allen	ISO
D162-1	DCLNR 2525 M16	150	36	25	32	25	0,432	TC044	TA022	TC095	BK018	BY040	BSP030	3 Allen	CNMG 1606
D165	DCLNR 3232 P16	170	36	32	40	32	1,407	TC044	TA022	TC095	BK018	BY040	BSP030	3 Allen	ISO
D163	DCLNR 2525 M19	150	40	25	32	25	0,820	TC047	TA017	TC039	BK025	BY044	BSP032	5 Allen	
D166	DCLNR 3232 P19	170	40	32	40	32	1,430	TC047	TA017	TC039	BK025	BY044	BSP032	5 Allen	CNMG 1909
D166-1	DCLNR 4040 S19	250	40	40	40	40	3,195	TC047	TA017	TC039	BK025	BY044	BSP032	5 Allen	ISO

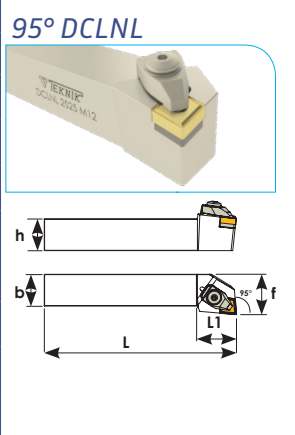

Order Code	Product Code	Dimensions (mm)													
		L	L1	h	f	b									
D301	DCLNL 2020 K12	125	30	20	25	20	0,441	TC044	TA016-1	TC038	BK020	BY040	BSP030	3 Allen	CNMG
D302	DCLNL 2525 M12	150	30	25	32	25	0,785	TC044	TA016-1	TC038	BK020	BY040	BSP030	3 Allen	1204
D305	DCLNL 3232 P12	170	30	32	40	32	1,379	TC044	TA016-1	TC038	BK020	BY040	BSP030	3 Allen	ISO
D303	DCLNL 2525 M16	150	36	25	32	25	0,432	TC044	TA022	TC095	BK018	BY040	BSP030	3 Allen	CNMG 1606
D306	DCLNL 3232 P16	170	36	32	40	32	1,407	TC044	TA022	TC095	BK018	BY040	BSP030	3 Allen	ISO
D304	DCLNL 2525 M19	150	40	25	32	25	0,820	TC047	TA017	TC039	BK025	BY044	BSP032	5 Allen	CNMG
D307	DCLNL 3232 P19	170	40	32	40	32	1,430	TC047	TA017	TC039	BK025	BY044	BSP032	5 Allen	1909
D307-2	DCLNL 4040 S19	250	40	40	40	40	3,195	TC047	TA017	TC039	BK025	BY044	BSP032	5 Allen	ISO

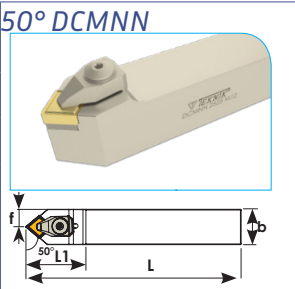

Order Code	Product Code	Dimensions (mm)													
		L	L1	h	f	b									
D214-1	DCMNN 2020 K12	125	35	20	10	20	0,445	TC044	TA016-1	TC038	BK020	BY040	BSP030	3 Allen	CNMG 1204
D215	DCMNN 2525 M12	150	35	25	12,5	25	0,778	TC044	TA016-1	TC038	BK020	BY040	BSP030	3 Allen	ISO.

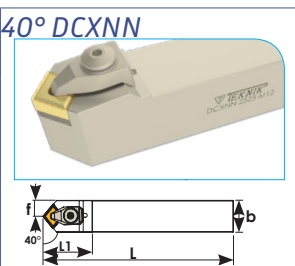

Order Code	Product Code	Dimensions (mm)													
		L	L1	h	f	b									
D216	DCXNN 2525 M12	150	35	25	12,5	25	0,756	TC044	TA016-1	TC038 M3x10	BK020	BY040	BSP030	3 Allen	CNMG 1204 ISO.



Order Code	Product Code	Dimensions (mm)						TC044	TA016-1	TC038	BK020	BY040	BSP030	3 Allen	CNMG 1204 ISO
		L	L1	h	f	b	kg								
D116-1	DCKNR 2525 M12	150	30	25	32	25	0,440								
D162-3	DCKNR 2525 M16	150	40	25	32	25	0,576		TA022	TC095	BK018	BY040	BSP030	3 Allen	CNMG 1606 ISO.

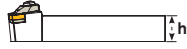
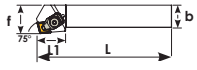

Order Code	Product Code	Dimensions (mm)						TC044	TA016-1	TC038	BK020	BY040	BSP030	3 Allen	CNMG 1204 ISO.
		L	L1	h	f	b	kg								
D218	DCSNR 2525 M12	150	35	25	32	25	0,774								



Order Code	Product Code	Dimensions (mm)						TC044	TA050	TC038	BK020	BY040	BSP030	3 Allen	SNMG 1204
		L	L1	h	f	b	kg								
D210	DSSNR 2020 K12	125	35	20	25	20	0,440								
D212	DSSNR 2525 M12	150	35	25	32	25	0,576								ISO.
D205	DSSNR 3232 P12	170	36	32	32	40	1,280								
D206	DSSNR 3232 P19	170	46	32	32	40	1,383	TA051	TC039	TC038	BK025	BY044	BSP032	5 Allen	SNMG 1906
D207	DSSNR 4040 S19	250	46	40	40	50	3,123	TA051	TC039	TC038	BK025	BY044	BSP032	5 Allen	ISO.
D208	DSSNR 4040 S25	250	60	40	40	50	3,012	TC047	TA053	TC041	BK027	BY044	BSP032	5 Allen	SNMG 2508

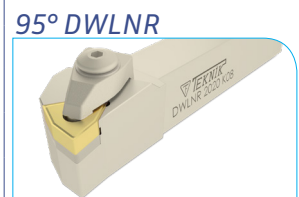
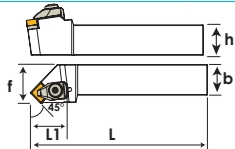

Order Code	Product Code	Dimensions (mm)						TC046	TA021	TC034	BK024	BY041	BSP031	3 Allen	WNMG
		L	L1	h	f	b	kg								
D181	DWLNR 1616 H06	100	26	16	20	16	0,229								
D177	DWLNR 2020 K06	125	26	20	25	20	0,436								0604
D179	DWLNR 2525 M06	150	26	25	32	25	0,772								ISO.
D176	DWLNR 2020 K08	125	32	20	25	20	0,442	TC044	TA020-1	TC038	BK020	BY040	BSP030	3 Allen	WNMG
D178	DWLNR 2525 M08	150	32	25	32	25	0,793	TC044	TA020-1	TC038	BK020	BY040	BSP030	3 Allen	0804
D180	DWLNR 3232 P08	170	32	32	40	32	1,377	TC044	TA020-1	TC038	BK020	BY040	BSP030	3 Allen	ISO.

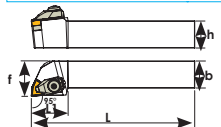

Order Code	Product Code	Dimensions (mm)						TC046	TA021	TC034	BK024	BY041	BSP031	3 Allen	WNMG
		L	L1	h	f	b	kg								
D328	DWLNL 1616 H06	100	26	16	20	16	0,229								
D329	DWLNL 2020 K06	125	26	20	25	20	0,436								0604
D319	DWLNL 2525 M06	150	26	25	32	25	0,772								ISO.
D316	DWLNL 2020 K08	125	32	20	25	20	0,442	TC044	TA020-1	TC038	BK020	BY040	BSP030	3 Allen	WNMG
D318	DWLNL 2525 M08	150	32	25	32	25	0,793	TC044	TA020-1	TC038	BK020	BY040	BSP030	3 Allen	0804
D320	DWLNL 3232 P08	170	32	32	40	32	1,377	TC044	TA020-1	TC038	BK020	BY040	BSP030	3 Allen	ISO.

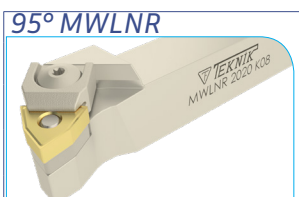
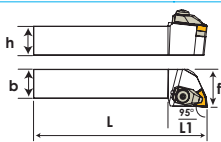

Order Code	Product Code	Dimensions (mm)						TC044	TA020	BSP021	BK026	BY040	BSP030	3 Allen	WNMG
		L	L1	h	f	b	kg								
D182	MWLNR 2020 K08	125	32	20	25	20	0,435								
D184	MWLNR 2525 M08	150	32	25	32	25	0,761								0804
D185	MWLNR 3232 P08	170	32	32	40	32	1,349								ISO.

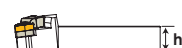
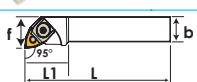

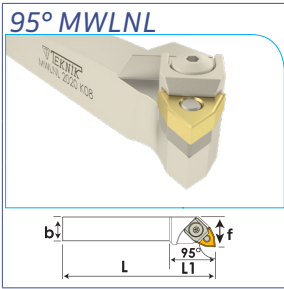

Order Code	Product Code	Dimensions (mm)													Material
		L	L1	h	f	b									
D322	MWLNL 2020 K08	125	32	20	25	20	0,435	TC044	TA020	BSP021	BK026	BY040	BSP030	3 Allen	WNMG
D324	MWLNL 2525 M08	150	32	25	32	25	0,761	TC044	TA020	BSP021	BK026	BY040	BSP030	3 Allen	0804
D326	MWLNL 3232 P08	170	32	32	40	32	1,349	TC044	TA020	BSP021	BK026	BY040	BSP030	3 Allen	ISO.

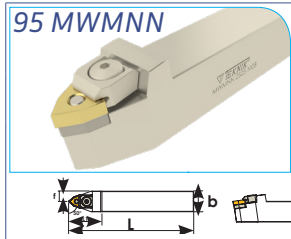

Order Code	Product Code	Dimensions (mm)													Material
		L	L1	h	f	b									
D114	MWMNN 2020 K08	125	40	20	10	20	0,432	TC044	TA020	BSP021	BK026	BY040	BSP030	3 Allen	WNMG 0804
D116	MWMNN 2525 M08	150	40	25	12,5	25	0,724	TC044	TA020	BSP021	BK026	BY040	BSP030	3 Allen	ISO

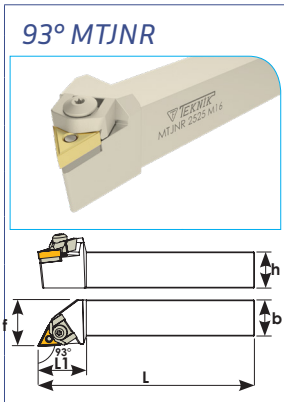

Order Code	Product Code	Dimensions (mm)													Material
		L	L1	h	f	b									
D194	MTJNR 2020 K16	125	35	20	25	20	0,429	TC046	TA019	BSP020	BK022	BY043	BSP031	3 Allen	TNMG 1604
D196	MTJNR 2525 M16	150	35	25	32	25	0,760	TC046	TA019	BSP020	BK022	BY043	BSP031	3 Allen	ISO.
D198	MTJNR 3232 P16	170	35	32	40	32	1,360	TC046	TA019	BSP020	BK022	BY043	BSP031	3 Allen	
D200	MTJNR 2020 K22	125	37	20	25	20	0,429	TC044	TA045	BSP021	BK023	BY040	BSP030	3 Allen	TNMG 2204
D202	MTJNR 2525 M22	150	40	25	32	25	0,775	TC044	TA045	BSP021	BK023	BY040	BSP030	3 Allen	ISO.
D204	MTJNR 3232 P22	170	40	32	40	32	1,348	TC044	TA045	BSP021	BK023	BY040	BSP030	3 Allen	

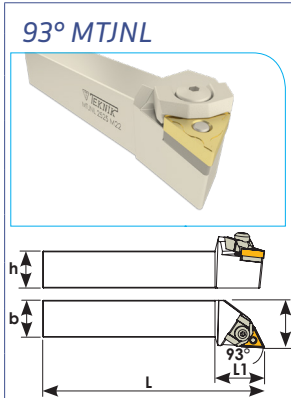

Order Code	Product Code	Dimensions (mm)													Material
		L	L1	h	f	b									
D332	MTJNL 2020 K16	125	35	20	25	20	0,429	TC046	TA019	BSP020	BK022	BY043	BSP031	3 Allen	
D334	MTJNL 2525 M16	150	35	25	32	25	0,760	TC046	TA019	BSP020	BK022	BY043	BSP031	3 Allen	TNMG 1604
D336	MTJNL 3232 P16	170	35	32	40	32	1,360	TC046	TA019	BSP020	BK022	BY043	BSP031	3 Allen	ISO.
D338	MTJNL 2020 K22	125	37	20	25	20	0,429	TC044	TA045	BSP021	BK023	BY040	BSP030	3 Allen	TNMG 2204
D340	MTJNL 2525 M22	150	40	25	32	25	0,775	TC044	TA045	BSP021	BK023	BY040	BSP030	3 Allen	ISO.
D342	MTJNL 3232 P22	170	40	32	40	32	1,348	TC044	TA045	BSP021	BK023	BY040	BSP030	3 Allen	

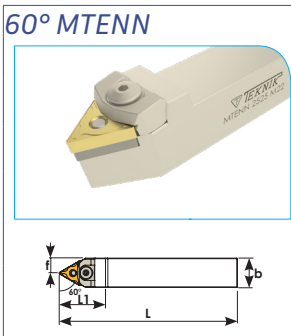

Order Code	Product Code	Dimensions (mm)													Material
		L	L1	h	f	b									
D108	MTENN 2020 K16	125	35	20	10	20	0,408	TC046	TA019	BSP020	BK022	BY043	BSP031	3 Allen	TNMG 1604
D110	MTENN 2525 M16	150	35	25	12,5	25	0,724	TC046	TA019	BSP020	BK022	BY043	BSP031	3 Allen	ISO.
D112	MTENN 2525 M22	150	40	25	12,5	25	0,734	TC044	TA045	BSP021	BK023	BK023	BSP030	3 Allen	TNMG 2204
D113	MTENN 3232 P22	170	40	32	16	32	1,311	TC044	TA045	BSP021	BK023	BK023	BSP030	3 Allen	ISO.

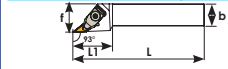

Order Code	Product Code	Dimensions (mm)						TC046	TA033	TC074	BK021	BY043	BSP031	3 Allen	VNMG 1604 ISO.
		L	L1	h	f	b	kg								
D105-1	DVJNR 2020 K16	125	40	20	27	20	0,428								
D105	DVJNR 2525 M16	150	40	25	32	25	0,427								

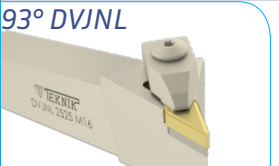
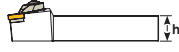

Order Code	Product Code	Dimensions (mm)						TC046	TA033	TC074	BK021	BY043	BSP031	3 Allen	VNMG 1604 ISO.
		L	L1	h	f	b	kg								
D343	DVJNL 2020 K16	125	40	20	27	20	0,428								
D344	DVJNL 2525 M16	150	40	25	32	25	0,427								

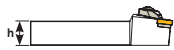

Order Code	Product Code	Dimensions (mm)						TC046	TA033	TC074	BK021	BY043	BSP031	3 Allen	VNMG 1604
		L	L1	h	f	b	kg								
D105-2	DVVNN 2525 M16	150	45	25	12,5	25	0,690								

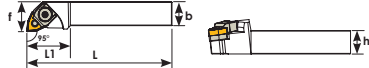

Order Code	Product Code	Dimensions (mm)						TC044	TA046	TC036	BK028	BY042	BSP030	3 Allen	KNUX 1604 ISO.
		L	L1	h	f	b	kg								
RD018	CKJNR 2020 K16	125	32	20	27	20	0,434								
RD014	CKJNR 2525 M16	150	35	25	30	25	0,753								
RD013	CKJNR 3232 P16	170	35	32	40	32	1,311								

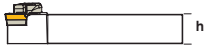

Order Code	Product Code	Dimensions (mm)						TC044	TA046	TC036	BK028	BY042	BSP030	3 Allen	KNUX 1604 ISO.
		L	L1	h	f	b	kg								
RD038	CKJNL 2020 K16	125	32	20	27	20	0,434								
RD034	CKJNL 2525 M16	150	35	25	30	25	0,753								
RD032	CKJNL 3232 P16	170	35	32	40	32	1,311								

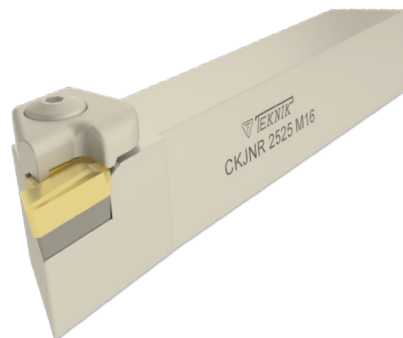
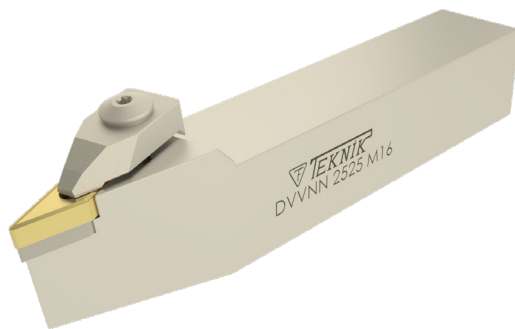
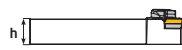

## S System External Turning Holder



[www.teknikcuttingtools.com](http://www.teknikcuttingtools.com)



Kalite için TEKNİK çözüm

Technical solution for quality

80-86



95° SCLCR

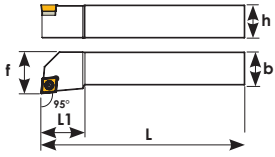
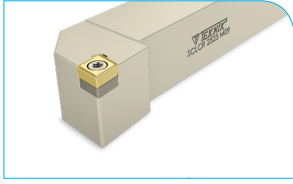

Order Code	Product Code	Dimensions (mm)						kg					
		L	L1	h	f	b	kg						
D398	SCLCR 1010 J06	110	10	10	12	10	0,105	TC060	--	--	T8	CCMT 0602 ISO.	
D400	SCLCR 1212 J09	110	16	12	16	12	0,140	TC067	--	--	T15		
D401	SCLCR 1616 H09	100	20	16	20	16	0,215	TC068	TA015	TC048	T15	CCMT 0903	
D402	SCLCR 2020 K09	125	25	20	25	20	0,425	TC068	TA015	TC048	T15	ISO.	
D403	SCLCR 2525 M09	150	25	25	32	25	0,772	TC068	TA015	TC048	T15		
D418	SCLCR 2020 K12	125	25	20	25	20	0,421	TC075	TA015-1	TC049-1	T15	CCMT 1204	
D403-1	SCLCR 2525 M12	150	25	25	32	25	0,768	TC075	TA015-1	TC049-1	T15	ISO.	

95° SCLCL

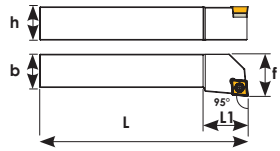
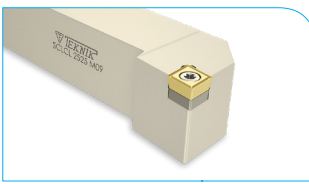

Order Code	Product Code	Dimensions (mm)						kg					
		L	L1	h	f	b	kg						
D404	SCLCL 1010 J06	110	10	10	12	10	0,105	TC060	--	--	T8	CCMT 0602 ISO.	
D405	SCLCL 1212 J09	110	16	12	16	12	0,140	TC067	--	--	T15		
D406	SCLCL 1616 H09	100	20	16	20	16	0,215	TC068	TA015	TC048	T15	CCMT 0903	
D407	SCLCL 2020 K09	125	25	20	25	20	0,425	TC068	TA015	TC048	T15	ISO.	
D408	SCLCL 2525 M09	150	25	25	32	25	0,772	TC068	TA015	TC048	T15		
D420	SCLCL 2020 K12	125	25	20	25	20	0,421	TC075	TA015-1	TC049-1	T15	CCMT 1204	
D421	SCLCL 2525 M12	150	25	25	32	25	0,768	TC075	TA015-1	TC049-1	T15	ISO.	

90° SCACR-F

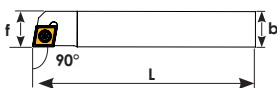
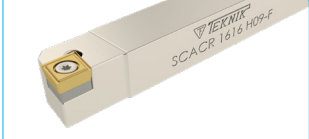

Order Code	Product Code	Dimensions (mm)						kg					
		L	L1	h	f	b	kg						
D411	SCACR 1010 J06-F	110	10	10	10	0,104	0,105	TC060	--	--	T8	CCMT 0602 ISO.	
D412	SCACR 1212 J09-F	110	12	12	12	0,143	0,140	TC067	--	--	T15		
D414	SCACR 1616 H09-F	100	16	16	16	0,221	0,215	TC068	TA015	TC048	T15	CCMT 0903	
D416	SCACR 2020 K09-F	125	20	20	20	0,420	0,425	TC068	TA015	TC048	T15	ISO.	

95° SCLCR-F

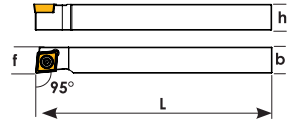
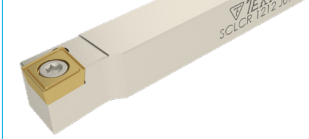

Order Code	Product Code	Dimensions (mm)						kg					
		L	L1	h	f	b	kg						
D422	SCLCR 1010 J06-F	110	10	10	10	10	0,106	TC060	--	--	T8	CCMT 0602	
D424	SCLCR 1212 J06-F	110	12	12	12	12	0,147	TC060	--	--	T8	ISO.	
D426	SCLCR 1212 J09-F	110	12	12	12	12	0,144	TC068	--	--	T15	CCMT 0903	
D428	SCLCR 1616 H09-F	100	16	16	16	16	0,424	TC068	TA015	TC048	T15	ISO.	
D430	SCLCR 2020 K09-F	125	20	20	20	20	0,426	TC068	TA015	TC048	T15		



93° SDJCR

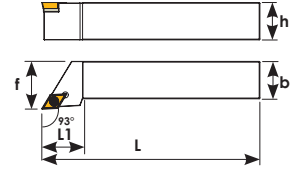
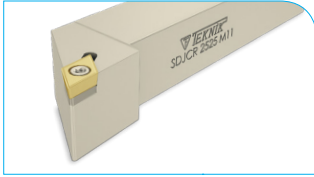

Order Code	Product Code	Dimensions (mm)						TC	Cutter	Screw	Screwdriver	ISO
		L	L1	h	f	b	kg					
D220	SDJCR 1010 J07	110	15	10	12	10	0,097	TC060	--	--	T8	DCMT 0702
D220-1	SDJCR 1212 K07	125	15	12	16	12	0,132	TC060	--	--	T8	ISO
D221	SDJCR 1616 H07	100	18	16	20	16	0,204	TC060	--	--	T8	
D221-1	SDJCR 2020 K07	125	20	20	25	20	0,404	TC060	--	--	T8	
D222	SDJCR 1212 J11	110	20	12	16	12	0,132	TC067	--	--	T15	
D224	SDJCR 1616 H11	100	25	16	20	16	0,204	TC068	TA030	TC048	T15	DCMT 11T3
D226	SDJCR 2020 K11	125	25	20	25	20	0,404	TC068	TA030	TC048	T15	ISO.
D228	SDJCR 2525 M11	150	30	25	32	25	0,735	TC068	TA030	TC048	T15	

93° SDJCL

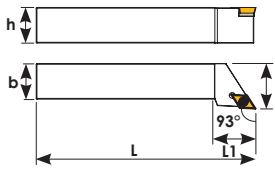
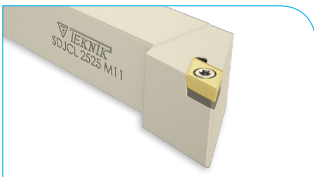

Order Code	Product Code	Dimensions (mm)						TC	Cutter	Screw	Screwdriver	ISO
		L	L1	h	f	b	kg					
D360	SDJCL 1010 J07	110	15	10	12	10	0,097	TC060	--	--	T8	DCMT 0702
D360-1	SDJCL 1212 K07	125	15	12	16	12	0,132	TC060	--	--	T8	ISO
D361	SDJCL 1616 H07	100	18	16	20	16	0,204	TC060	--	--	T8	
D361-1	SDJCL 2020 K07	125	20	20	25	20	0,404	TC060	--	--	T8	
D362	SDJCL 1212 J11	110	20	12	16	12	0,132	TC067	--	--	T15	
D364	SDJCL 1616 H11	100	25	16	20	16	0,204	TC068	TA030	TC048	T15	DCMT 11T3
D366	SDJCL 2020 K11	125	25	20	25	20	0,404	TC068	TA030	TC048	T15	ISO.
D368	SDJCL 2525 M11	150	30	25	32	25	0,735	TC068	TA030	TC048	T15	

62,5° SDNCN

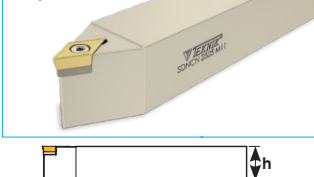

Order Code	Product Code	Dimensions (mm)						TC	Cutter	Screw	Screwdriver	ISO
		L	L1	h	f	b	kg					
D117	SDNCN 1010 J07	110	15	10	5	10	0,096	TC060	--	--	T8	DCMT 0702 ISO
D118	SDNCN 1212 J11	110	25	12	6	12	0,131	TC067	--	--	T15	
D120	SDNCN 1616 H11	100	25	16	8	16	0,196	TC068	TA030	TC048	T15	DCMT 11T3
D122	SDNCN 2020 K11	125	25	20	10	20	0,390	TC068	TA030	TC048	T15	ISO.
D124	SDNCN 2525 M11	150	25	25	12,5	25	0,705	TC068	TA030	TC048	T15	

90° SDACR-F

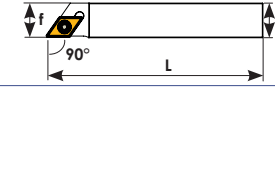
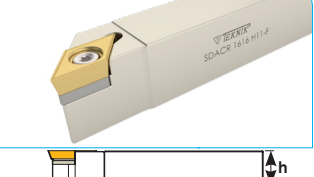

Order Code	Product Code	Dimensions (mm)						TC	Cutter	Screw	Screwdriver	ISO
		L	L1	h	f	kg						
D434	SDACR 1010 J07-F	110	10	10	10	0,970	TC060	--	--	T8	DCMT 0702	
D436	SDACR 1212 J07-F	110	12	12	12	0,135	TC060	--	--	T8	ISO.	
D438	SDACR 1616 H07-F	100	16	16	16	0,207	TC060	--	--	T8		
D440	SDACR 1212 J11-F	110	12	12	12	0,135	TC067	--	--	T15		
D442	SDACR 1616 H11-F	100	16	16	16	0,200	TC067	TA030	TC048	T15	DCMT 11T3	
D444	SDACR 2020 K11-F	125	20	20	20	0,397	TC067	TA030	TC048	T15	ISO.	

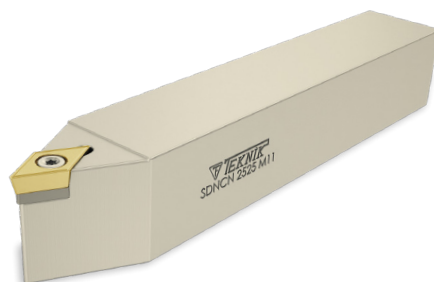



Order Code	Product Code	Dimensions (mm)						kg					
		L	L1	h	f	b	kg						
D452	SDJCR 1010 J07-F	110	10	10	10	10	0,103	TC060	--	--	T8	DCMT 0702	
D454	SDJCR 1212 J07-F	110	12	12	12	12	0,131	TC060	--	-	T8	ISO.	
D456	SDJCR 1616 H07-F	100	16	16	16	16	0,192	TC067	TA030	TC048	T15		
D457	SDJCR 1212 J11-F	110	12	12	12	12	0,134	TC067	TA030	TC048	T15	DCMT 11T3 ISO.	
D458	SDJCR 1616 H11-F	100	16	16	16	16	0,181	TC067	TA030	TC048	T15		

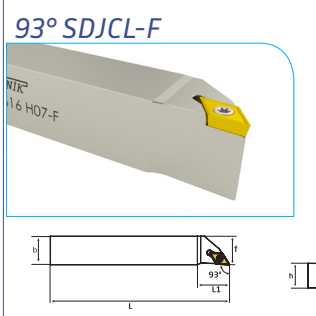

Order Code	Product Code	Dimensions (mm)						kg					
		L	L1	h	f	b	kg						
D154	SDJCL 1212 K07-F	125	15	12	12	12	0,135	TC060	--	--	T8	DCMT 0702	
D155	SDJCL 1616 H07-F	100	18	16	16	16	0,152	TC060	--	-	T8	ISO.	
D156	SDJCL 1212 J11-F	110	20	12	12	12	0,134	TC067	TA030	TC048	T15	DCMT 11T3	
D157	SDJCL 1616 H11-F	100	25	16	16	16	0,180	TC067	TA030	TC048	T15	ISO.	

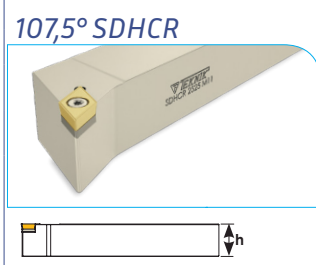

Order Code	Product Code	Dimensions (mm)						kg					
		L	L1	h	f	b	kg						
D250	SDHCR 2020 K11	125	25	20	25	20	0,411	TC068	TA030	TC048	T15	DCMT 11T3	
D252	SDHCR 2525 M11	150	25	25	32	25	0,738	TC068	TA030	TC048	T15	ISO.	

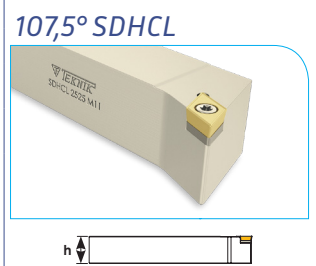

Order Code	Product Code	Dimensions (mm)						kg					
		L	L1	h	f	b	kg						
D350	SDHCL 2020 K11	125	25	20	25	20	0,411	TC068	TA030	TC048	T15	DCMT 11T3	
D352	SDHCL 2525 M11	150	25	25	32	25	0,738	TC068	TA030	TC048	T15	ISO.	

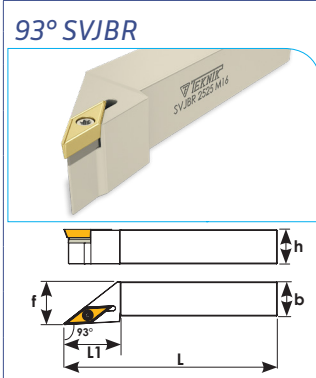

Order Code	Product Code	Dimensions (mm)						kg					
		L	L1	h	f	b	kg						
D230	SVJBR 1010 J11	110	21	10	12	10	0,097	TC061	--	--	T8	VBMT 1103	
D232	SVJBR 1212 J11	110	21	12	16	12	0,141	TC061	--	--	T8	ISO.	
D234	SVJBR 1616 H11	100	25	16	20	16	0,192	TC061	--	--	T8		
D235	SVJBR 1616 H16	100	33	16	20	16	0,192	TC068	TA034	TC048	T15	VBMT 1604	
D236	SVJBR 2020 K16	125	33	20	25	20	0,382	TC068	TA034	TC048	T15	ISO.	
D238	SVJBR 2525 M16	150	40	25	32	25	0,688	TC068	TA034	TC048	T15		
D238-1	SVJBR 3232 P16	170	40	32	40	32	1,370	TC068	TA034	TC048	T15		

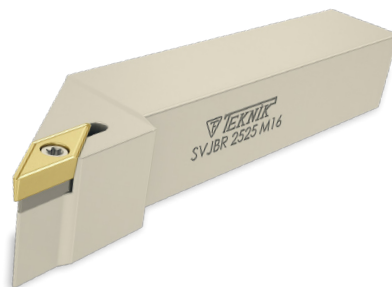

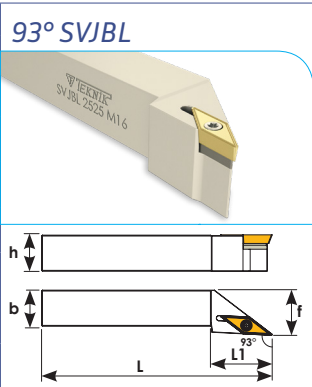

Order Code	Product Code	Dimensions (mm)						TC	TA	TC	T	ISO
		L	L1	h	f	b	kg					
D370	SVJBL 1010 J11	110	21	10	12	10	0,097	TC061	--	--	T8	VBMT 1103
D372	SVJBL 1212 J11	110	21	12	16	12	0,141	TC061	--	--	T8	ISO.
D373	SVJBL 1616 H11	100	25	16	20	16	0,192	TC061	--	--	T8	
D374	SVJBL 1616 H16	100	33	16	20	16	0,192	TC068	TA034	TC048	T15	VBMT 1604
D380	SVJBL 2020 K16	125	33	20	25	20	0,382	TC068	TA034	TC048	T15	ISO.
D382	SVJBL 2525 M16	150	40	25	32	25	0,688	TC068	TA034	TC048	T15	
D382-1	SVJBL 3232 P16	170	40	32	40	32	1,370	TC068	TA034	TC048	T15	

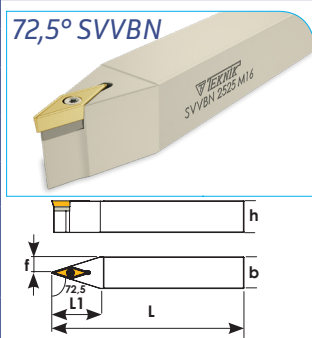

Order Code	Product Code	Dimensions (mm)						TC	TA	TC	T	ISO
		L	L1	h	f	b	kg					
D131	SVVBN 1212 J11	110	25	12	6	12	0,129	TC061	--	--	T8	VBMT 1103 ISO
D132	SVVBN 1616 H16	100	33	16	8	16	0,184	TC068	TA034	TC048	T15	VBMT 1604
D138	SVVBN 2020 K16	125	35	20	10	20	0,370	TC068	TA034	TC048	T15	ISO.
D140	SVVBN 2525 M16	150	40	25	12,5	25	0,668	TC068	TA034	TC048	T15	
D141	SVVBN 3232-P16	170	40	32	40	32	1,386	TC068	TA034	TC048	T15	

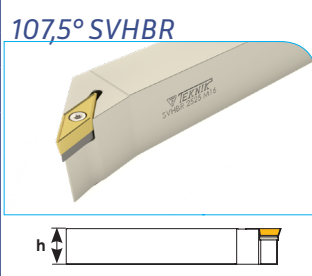

Order Code	Product Code	Dimensions (mm)						TC	TA	TC	T	ISO
		L	L1	h	f	b	kg					
D354-1	SVHBR 2020 K16	125	30	20	25	20	0,387	TC068	TA034	TC048	T15	VBMT 1604
D356-1	SVHBR 2525 M16	150	30	25	32	25	0,712	TC068	TA034	TC048	T15	ISO.

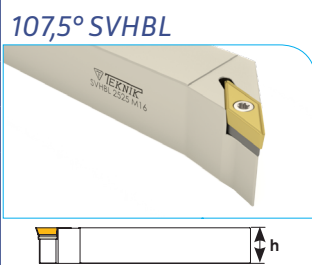

Order Code	Product Code	Dimensions (mm)						TC	TA	TC	T	ISO
		L	L1	h	f	b	kg					
D355	SVHBL 2020 K16	125	30	20	25	20	0,387	TC068	TA034	TC048	T15	VBMT 1604
D356-2	SVHBL 2525 M16	150	30	25	32	25	0,712	TC068	TA034	TC048	T15	ISO.

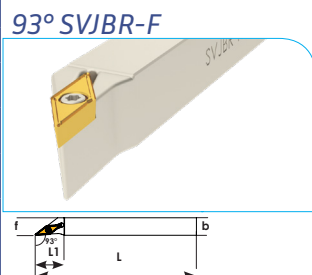

Order Code	Product Code	Dimensions (mm)						TC	T	ISO
		L	L1	h	f	b	kg			
D128	SVJBR 1010 J11-F	110	22	10	10	10	0,098	TC061	T8	VBMT 1103
D129	SVJBR 1212 J11-F	110	22	12	12	12	0,132	TC061	T8	ISO.
D130	SVJBR 1616 H11-F	100	25	16	16	16	0,204	TC061	T8	

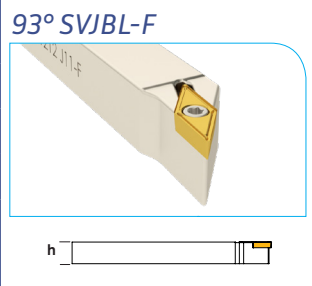

Order Code	Product Code	Dimensions (mm)						TC	T	ISO
		L	L1	h	f	b	kg			
D395	SVJBL 1010 J11-F	110	22	10	10	10	0,098	TC061	T8	VBMT 1103
D396	SVJBL 1212 J11-F	110	22	12	12	12	0,132	TC061	T8	ISO.
D397	SVJBL 1616 H11-F	100	25	16	16	16	0,204	TC061	T8	

93° SVJCR

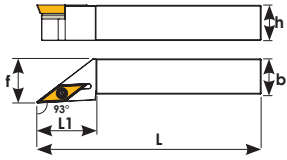

Order Code	Product Code	Dimensions (mm)						TC	TA	TC	T	ISO
		L	L1	h	f	b	kg					
D239	SVJCR 1010 J11	110	21	10	12	10	0,086	TC061	--	--	T8	
D240	SVJCR 1212 J11	110	21	12	16	12	0,135	TC061	--	--	T8	VCMT 1103
D241	SVJCR 1616 H11	100	25	16	20	16	0,204	TC061	--	--	T8	ISO.
D242	SVJCR 2020 K11	125	33	20	25	20	0,378	TC061	--	--	T8	
D243	SVJCR 2525 M11	150	40	25	32	25	0,738	TC061	--	--	T8	
D244	SVJCR 1616 H16	100	33	16	20	16	0,195	TC068	TA034	TC048	T15	VCMT 1604
D246	SVJCR 2020 K16	125	33	20	25	20	0,385	TC068	TA034	TC048	T15	ISO.
D248	SVJCR 2525 M16	150	40	25	32	25	0,683	TC068	TA034	TC048	T15	
D249	SVJCR 3232 P16	170	50	32	40	32	1,284	TC068	TA034	TC048	T15	

93° SVJCL

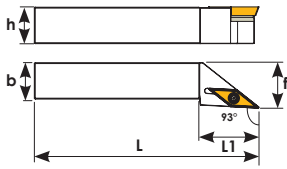
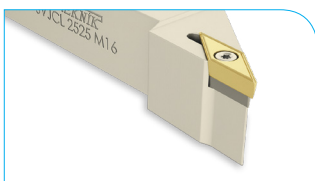

Order Code	Product Code	Dimensions (mm)						TC	TA	TC	T	ISO
		L	L1	h	f	b	kg					
D383	SVJCL 1010 J11	110	21	10	12	10	0,086	TC061	--	--	T8	
D384	SVJCL 1212 J11	110	21	12	16	12	0,135	TC061	--	--	T8	VCMT 1103
D385	SVJCL 1616 H11	100	25	16	20	16	0,204	TC061	--	--	T8	ISO.
D386	SVJCL 2020 K11	125	33	20	25	20	0,378	TC061	--	--	T8	
D387	SVJCL 2525 M11	150	40	25	32	25	0,738	TC061	--	--	T8	
D388	SVJCL 1616 H16	100	33	16	20	16	0,195	TC068	TA034	TC048	T15	VCMT 1604
D390	SVJCL 2020 K16	125	33	20	25	20	0,385	TC068	TA034	TC048	T15	ISO.
D392	SVJCL 2525 M16	150	40	25	32	25	0,683	TC068	TA034	TC048	T15	
D393	SVJCL 3232 P16	170	50	32	40	32	1,284	TC068	TA034	TC048	T15	

90° SVJCR -F

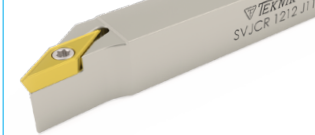

Order Code	Product Code	Dimensions (mm)					TC	T	ISO
		L	h	f	b	kg			
D460	SVJCR 1212 J11-F	110	12	12	12	0,134	TC061	T8	VCMT 1103
D462	SVJCR 1616 H11-F	100	16	16	16	0,202	TC061	T8	ISO.

72,5° SVVCN

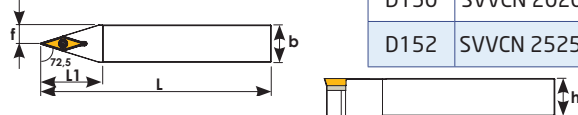

Order Code	Product Code	Dimensions (mm)						TC	TA	TC	T	ISO
		L	L1	h	f	b	kg					
D142	SVVCN 1212 J11	110	22	12	6	12	0,127	TC061	--	--	T8	VCMT 1103 ISO
D144	SVVCN 1616 H16	100	35	16	8	16	0,187	TC068	TA034	TC048	T15	VCMT 1604
D150	SVVCN 2020 K16	125	35	20	10	20	0,373	TC068	TA034	TC048	T15	ISO.
D152	SVVCN 2525 M16	150	40	25	12,5	25	0,675	TC068	TA034	TC048	T15	

**107,5° SVHCR**

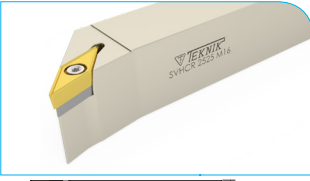

Order Code	Product Code	Dimensions (mm)											
		L	L1	h	f	b	kg						
D254	SVHCR 2020 K16	125	30	20	25	20	0,384	TC068	TA034	TC048	T15	VCMT 1604	
D256	SVHCR 2525 M16	150	30	25	32	25	0,707	TC068	TA034	TC048	T15	ISO.	

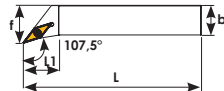

**107,5° SVHCL**



Order Code	Product Code	Dimensions (mm)											
		L	L1	h	f	b	kg						
D354	SVHCL 2020 K16	125	30	20	25	20	0,384	TC068	TA034	TC048	T15	VCMT 1604	
D356	SVHCL 2525 M16	150	30	25	32	25	0,707	TC068	TA034	TC048	T15	ISO.	

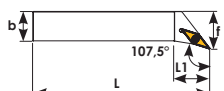

**45° SSDCR**

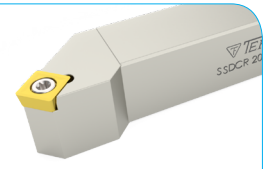

Order Code	Product Code	Dimensions (mm)								
		L	L1	h	b	f	kg			
D464	SSDCR 1616 H09	100	20	16	16	20	0,193	TC074	T15	SCMT 09T3
D465	SSDCR 2020 K09	125	25	20	20	25	0,373	TC074	T15	SCMT 09T3
D466	SSDCR 2020 K12	125	25	20	20	25	0,374	TC083	T20	SCMT 1204
D467	SSDCR 2525 M12	150	30	25	25	32	0,695	TC083	T20	SCMT 1204



**45° SSDCL**



Order Code	Product Code	Dimensions (mm)								
		L	L1	h	b	f	kg			
D468	SSDCL 1616 H09	100	20	16	16	20	0,193	TC074	T15	SCMT 09T3
D469	SSDCL 2020 K09	125	25	20	20	25	0,373	TC074	T15	SCMT 09T3
D470	SSDCL 2020 K12	125	25	20	20	25	0,374	TC083	T20	SCMT 1204
D471	SSDCL 2525 M12	150	30	25	25	32	0,695	TC083	T20	SCMT 1204

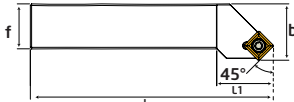
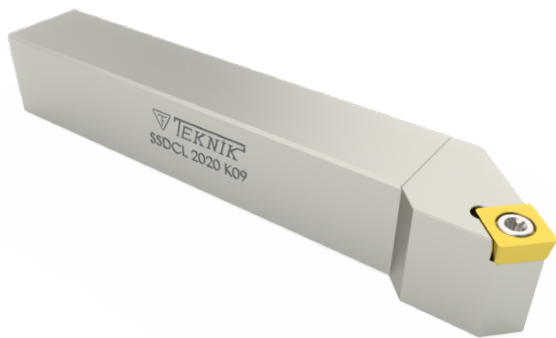

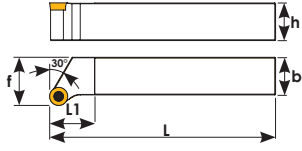
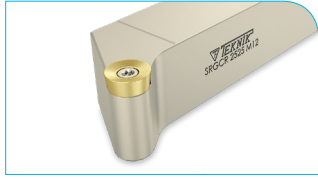

### 30° SRGCR

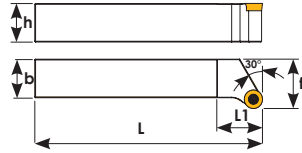

Order Code	Product Code	Dimensions (mm)						TC	Screw	Key	ISO
		L	L1	h	f	b	kg				
D280	SRGCR 2020 K08	125	25	20	25	20	0,411	TC065	T8	RCMT 0803	
D282	SRGCR 2525 M08	150	30	25	32	25	0,710	TC065	T8	ISO.	
D284	SRGCR 2020 K10	125	25	20	25	20	0,410	TC067	T15	RCMT 10T3	
D286	SRGCR 2525 M10	150	30	25	32	25	0,720	TC067	T15	ISO.	
D288	SRGCR 2020 K12	125	25	20	25	20	0,422	TC067	T15	RCMT 1204	
D290	SRGCR 2525 M12	150	30	25	32	25	0,744	TC067	T15	ISO.	

### 30° SRGCL



Order Code	Product Code	Dimensions (mm)						TC	Screw	Key	ISO
		L	L1	h	f	b	kg				
D293	SRGCL 2020 K08	125	25	20	25	20	0,411	TC065	T8	RCMT 0803	
D294	SRGCL 2525 M08	150	30	25	32	25	0,710	TC065	T8	ISO.	
D283	SRGCL 2020 K10	125	25	20	25	20	0,410	TC067	T15	RCMT 10T3	
D292	SRGCL 2525 M10	150	30	25	32	25	0,720	TC067	T15	ISO.	
D281	SRGCL 2020 K12	125	25	20	25	20	0,422	TC067	T15	RCMT 1204	
D291	SRGCL 2525 M12	150	30	25	32	25	0,744	TC067	T15	ISO.	

### SRDCN

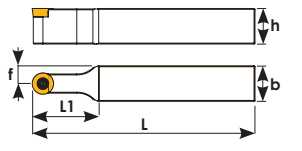
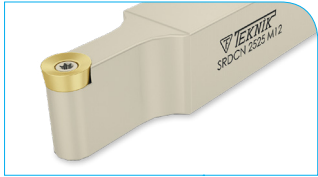

Order Code	Product Code	Dimensions (mm)						TC	Screw	Key	ISO
		L	L1	h	f	b	kg				
D270	SRDCN 2020 K08	125	37	20	10	20	0,358	TC065	T8	RCMT 0803	
D271	SRDCN 2525 M08	150	37	25	12.5	25	0,653	TC065	T8	ISO.	
D272	SRDCN 2020 K10	125	35	20	10	20	0,370	TC067	T15	RCMT 10T3	
D274	SRDCN 2525 M10	150	35	25	12.5	25	0,670	TC067	T15	ISO.	
D276	SRDCN 2020 K12	125	33	20	10	20	0,372	TC067	T15	RCMT 1204	
D278	SRDCN 2525 M12	150	38	25	12.5	25	0,668	TC067	T15	ISO.	
D273	SRDCN 2525 M16	150	35	25	12.5	25	0,701	TC083	T15	RCMT 1606 ISO.	

### TIRTIL Kater

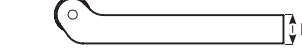
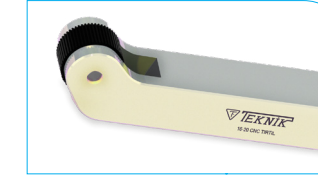

Order Code	Product Code	TC	Screw	Dimensions (mm)			
				L	h	b	kg
P100	16-20 CNC TIRTIL	20x10x6	BSP041 6-23	125	16	20	0,351
P102	20-20 CNC TIRTIL	20x10x6	BSP041 6-18	125	20	20	0,427
P104	25-25 CNC TIRTIL	20x10x6	BSP040 6-23	150	25	25	0,600



## P System Boring Bars

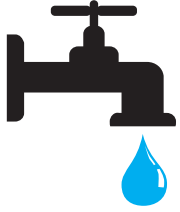

[www.teknikcuttingtools.com](http://www.teknikcuttingtools.com)



Kalite için TEKNİK çözüm

Technical solution for quality

88-90



**93° PDUNR IC**  
With Coolant

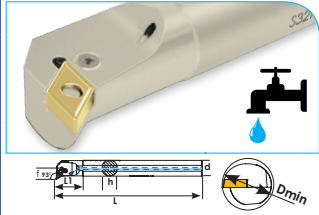

Order Code	Product Code	Dimensions (mm)							K	T	S	R	L	A
		Dmin	d	L	L1	f	h	⊙						
AP299	A20R PDUNR 11	25	20	200	40	13	18	0,500	TH512	--	--	TL3B	2 Allen	DNMG 1104
AP300	A25S PDUNR 15	32	25	250	50	17	23	0,900	TH6134	--	--	TL4A	2,5 Allen	
AP302	A32T PDUNR 15	40	32	300	55	22	30	1,770	TH821	TA014-1	TS-4	TL4B	3 Allen	DNMG 1506
AP304	A40T PDUNR 15	50	40	300	55	27	38	1,790	TH821	TA014-1	TS-4	TL4B	3 Allen	ISO.

**93° PDUNR**

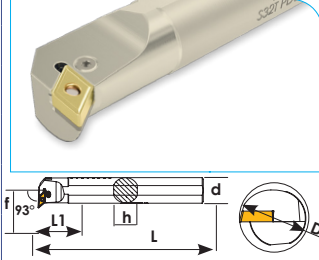

Order Code	Product Code	Dimensions (mm)							K	T	S	R	L	A
		Dmin	d	L	L1	f	h	⊙						
P300	S25S PDUNR 15	32	25	250	50	17	23	0,930	TH6134	--	--	TL4A	2,5 Allen	
P302	S32T PDUNR 15	40	32	300	55	22	30	1,805	TH821	TA014-1	TS-4	TL4B	3 Allen	DNMG 1506
P304	S40T PDUNR 15	50	40	300	55	27	38	2,790	TH821	TA014-1	TS-4	TL4B	3 Allen	ISO.

**93° PDUNL IC** With Coolant

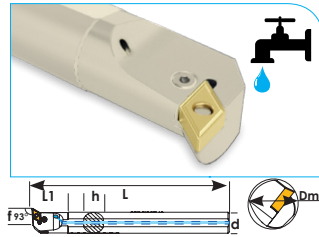

Order Code	Product Code	Dimensions (mm)							K	T	S	R	L	A
		Dmin	d	L	L1	f	h	⊙						
AP309	A20R PDUNL 11	25	20	200	40	13	18	0,500	TH512	--	--	TL3B	2 Allen	DNMG 1104
AP310	A25S PDUNL 15	32	25	250	50	17	23	0,900	TH6134	--	--	TL4A	2,5 Allen	
AP312	A32T PDUNL 15	40	32	300	55	22	30	1,770	TH821	TA014-1	TS-4	TL4B	3 Allen	DNMG 1506
AP314	A40T PDUNL 15	50	40	300	55	27	38	1,790	TH821	TA014-1	TS-4	TL4B	3 Allen	ISO.

**93° PDUNL**

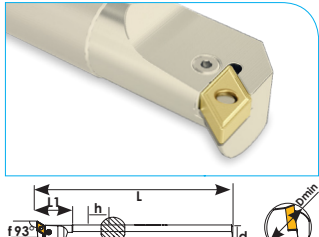

Order Code	Product Code	Dimensions (mm)							K	T	S	R	L	A
		Dmin	d	L	L1	f	h	⊙						
P310	S25S PDUNL 15	32	25	250	50	17	23	0,930	TH6134	--	--	TL4A	2,5 Allen	
P312	S32T PDUNL 15	40	32	300	55	22	30	1,805	TH821	TA014-1	TS-4	TL4B	3 Allen	DNMG 1506
P314	S40T PDUNL 15	50	40	300	55	27	38	2,790	TH821	TA014-1	TS-4	TL4B	3 Allen	ISO.

**95° PCLNR IC** With Coolant

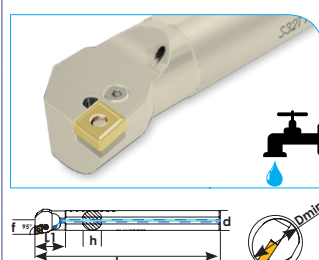

Order Code	Product Code	Dimensions (mm)							K	T	S	R	L	A
		Dmin	d	L	L1	f	h	⊙						
AP337	A20R PCLNR 09	25	20	200	40	13	18	0,435	THB617	TA023	TS3	TL3	2,5 Allen	CNMG 09T3
AP338	A20R PCLNR 12	24	20	200	50	13	18	0,520	TH6134	--	--	TL4A	2,5 Allen	
AP340	A25S PCLNR 12	32	25	250	50	17	23	0,921	TH6134	--	--	TL4A	2,5 Allen	CNMG 1204
AP342	A32T PCLNR 12	40	32	300	50	22	30	1,809	TH821	TA016-1	TS-4	TL4	3 Allen	ISO.
AP344	A40T PCLNR 12	50	40	300	55	27	38	1,820	TH821	TA016-1	TS-4	TL4	3 Allen	



95° PCLNR

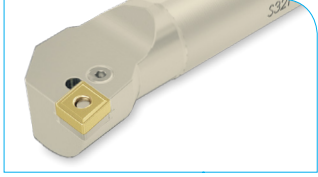

Order Code	Product Code	Dimensions (mm)							kg						
		Dmin	d	L	L1	f	h								
P338	S20R PCLNR 12	24	20	200	50	13	18	0,540	TH6134	--	--	TL4A	2,5 Allen		
P340	S25S PCLNR 12	32	25	250	50	17	23	0,978	TH6134	--	--	TL4A	2,5 Allen	CNMG 1204	
P342	S32T PCLNR 12	40	32	300	50	22	30	1,815	TH821	TA016-1	TS-4	TL4	3 Allen	ISO.	
P344	S40T PCLNR 12	50	40	300	55	27	38	1,825	TH821	TA016-1	TS-4	TL4	3 Allen		

95° PCLNL IC

With Coolant

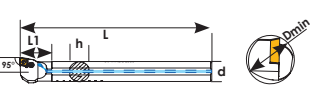
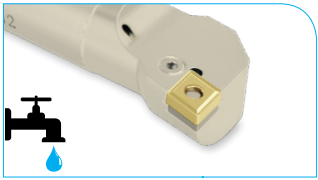

Order Code	Product Code	Dimensions (mm)							kg						
		Dmin	d	L	L1	f	h								
AP347	A20R PCLNL 09	25	20	200	40	13	18	0,435	THB617	TA023	TS3	TL3	2,5 Allen	CNMG 09T3	
AP348	A20R PCLNL 12	24	20	200	50	13	18	0,520	TH6134	--	--	TL4A	2,5 Allen		
AP350	A25S PCLNL 12	32	25	250	50	17	23	0,921	TH6134	--	--	TL4A	2,5 Allen	CNMG 1204	
AP352	A32T PCLNL 12	40	32	300	50	22	30	1,809	TH821	TA016-1	TS-4	TL4	3 Allen	ISO.	
AP354	A40T PCLNL 12	50	40	300	55	27	38	1,820	TH821	TA016-1	TS-4	TL4	3 Allen		

95° PCLNL

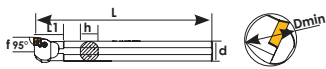

Order Code	Product Code	Dimensions (mm)							kg						
		Dmin	d	L	L1	f	h								
P348	Z0R PCLNL 12	24	20	200	50	13	18	0,540	TH6134	--	--	TL4A	2,5 Allen		
P350	S25S PCLNL 12	32	25	250	50	17	23	0,978	TH6134	--	--	TL4A	2,5 Allen	CNMG 1204	
P352	S32T PCLNL 12	40	32	300	50	22	30	1,815	TH821	TA016-1	TS-4	TL4	3 Allen	ISO.	
P354	S40T PCLNL 12	50	40	300	55	27	38	1,825	TH821	TA016-1	TS-4	TL4	3 Allen		

95° PWLNR 08 IC

With Coolant

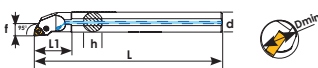
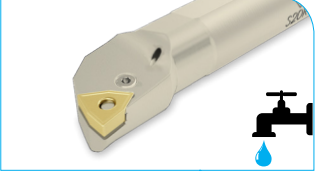

Order Code	Product Code	Dimensions (mm)							kg						
		Dmin	d	L	L1	f	h								
AP360	A25S PWLNR 08	32	25	250	50	17	23	0,911	TH6134	--	--	TL4A	2,5 Allen	WNMG 0804	
AP362	A32T PWLNR 08	40	32	300	60	22	30	1,764	TH6134	--	--	TL4A	2,5 Allen	ISO.	
AP364	A40T PWLNR 08	50	40	300	60	27	38	2,800	TH821	TA016-1	TS-4	TL4	3 Allen		

95° PWLNR 08

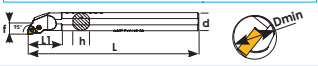
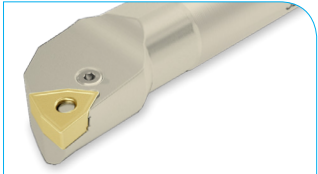

Order Code	Product Code	Dimensions (mm)							kg						
		Dmin	d	L	L1	f	h								
P360	S25S PWLNR 08	32	25	250	50	17	23	0,911	TH6134	--	--	TL4A	2,5 Allen	WNMG 0804	
P362	S32T PWLNR 08	40	32	300	60	22	30	1,764	TH821	TA020-1	TS-4	TL4	3 Allen	ISO.	
P364	S40T PWLNR 08	50	40	300	60	27	38	2,450	TH821	TA020-1	TS-4	TL4	3 Allen		



95° PWLNL 08 IC *With Coolant*



Order Code	Product Code	Dimensions (mm)							kg						
		Dmin	d	L	L1	f	h								
AP370	A25S PWLNL 08	32	25	250	50	17	23	0,911	TH6134	--	--	TL4A	2,5 Allen	WNMG 0804	
AP372	A32T PWLNL 08	40	32	300	60	22	30	1,764	TH6134	--	--	TL4A	2,5 Allen	ISO.	
AP374	A40T PWLNL 08	50	40	300	60	27	38	2,800	TH821	TA016-1	TS-4	TL4	3 Allen		

95° PWLNL 08

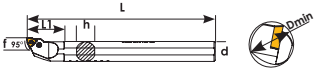

Order Code	Product Code	Dimensions (mm)							kg						
		Dmin	d	L	L1	f	h								
P370	S25S PWLNL 08	32	25	250	50	17	23	0,911	TH6134	--	--	TL4A	2,5 Allen	WNMG 0804	
P372	S32T PWLNL 08	40	32	300	60	22	30	1,764	TH821	TA020-1	TS-4	TL4	3 Allen	ISO.	
P374	S40T PWLNL 08	50	40	300	60	27	38	2,450	TH821	TA020-1	TS-4	TL4	3 Allen		

95° PWLNR 06 IC *With Coolant*

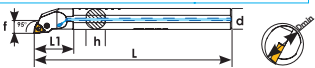
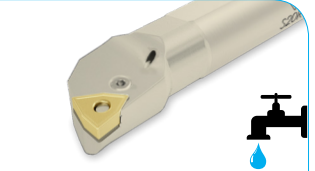

Order Code	Product Code	Dimensions (mm)							kg						
		Dmin	d	L	L1	f	h								
AP380	A16R PWLNR 06	20	16	200	40	11	15	0,326	TH512 M5			TL3B	2 Allen	WNMG 0604	
AP382	A20R PWLNR 06	25	20	200	40	13	18	0,471	TH512 M5			TL3B	2 Allen	ISO.	

95° PWLNR 06



Order Code	Product Code	Dimensions (mm)							kg						
		Dmin	d	L	L1	f	h								
P380	S16R PWLNR 06	20	16	200	40	11	15	0,316	TH512 M5			TL3B	2 Allen	WNMG 0604	
P382	S20R PWLNR 06	25	20	200	40	13	18	0,502	TH512 M5			TL3B	2 Allen	ISO.	

95° PWLNL 06 IC *With Coolant*



Order Code	Product Code	Dimensions (mm)							kg						
		Dmin	d	L	L1	f	h								
AP388	A16R PWLNL 06	20	16	200	40	11	15	0,326	TH512 M5			TL3B	2 Allen	WNMG 0604	
AP390	A20R PWLNL 06	25	20	200	40	13	18	0,471	TH512 M5			TL3B	2 Allen	ISO.	

95° PWLNL 06

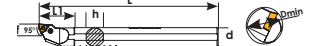
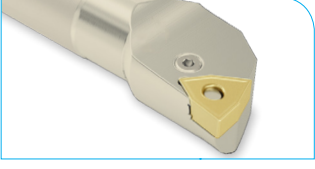

Order Code	Product Code	Dimensions (mm)							kg						
		Dmin	d	L	L1	f	h								
P388	S16R PWLNL 06	20	16	200	40	11	15	0,316	TH512 M5			TL3B	2 Allen	WNMG 0604	
P390	S20R PWLNL 06	25	20	200	40	13	18	0,502	TH512 M5			TL3B	2 Allen	ISO.	

## D-M System Boring Bars



[www.teknikcuttingtools.com](http://www.teknikcuttingtools.com)



Kalite için TEKNİK çözüm  
Technical solution for quality

92-95



93° DDUNR

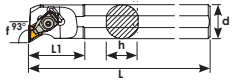
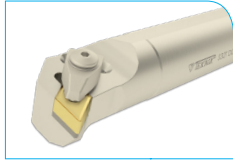

Order Code	Product Code	Dimensions (mm)							TC	TA	TC	BK	BY	BSP	3 Allen	Coating
		Dmin	d	L	L1	f	h	kg								
K408	S20R DDUNR 11	30	20	200	50	13	18	0,508	TC046	TA013	TC034	BK024	BY041	BSP031	3 Allen	DNMG 1104
K409	S25S DDUNR 11	32	25	250	50	17	23	0,956	TC046	TA013	TC034	BK024	BY041	BSP031	3 Allen	ISO.
K410	S25S DDUNR 15	32	25	250	50	17	23	0,950	TC044	TA014-1	TC038	BK020	BY040	BSP030	3 Allen	
K412	S32T DDUNR 15	40	32	300	55	22	30	1,835	TC044	TA014-1	TC038	BK020	BY040	BSP030	3 Allen	
K414	S40T DDUNR 15	50	40	300	60	27	38	2,848	TC044	TA014-1	TC038	BK020	BY040	BSP030	3 Allen	
K415	S40U DDUNR 15	50	40	350	60	27	38	3,336	TC044	TA014-1	TC038	BK020	BY040	BSP030	3 Allen	DNMG
K416	S50U DDUNR 15	63	50	350	65	35	47	5,153	TC044	TA014-1	TC038	BK020	BY040	BSP030	3 Allen	1506
K417	S50X DDUNR 15	63	50	550	65	35	47	8,716	TC044	TA014-1	TC038	BK020	BY040	BSP030	3 Allen	ISO.
K417-1	S60X DDUNR 15	73	60	600	65	37,5	57	13,66	TC044	TA014-1	TC038	BK020	BY040	BSP030	3 Allen	
K411	S25S DDUNR 15	32	25	250	50	17	23	0,958	TC044	TA014-1	TC038	BK020	BY040	BSP030	3 Allen	DNMG 1504
K413	S32T DDUNR 15	40	32	300	55	22	30	1,830	TC044	TA014-1	TC038	BK020	BY040	BSP030	3 Allen	ISO.

93° DDUNL

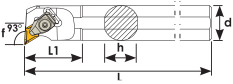
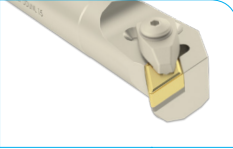

Order Code	Product Code	Dimensions (mm)							TC	TA	TC	BK	BY	BSP	3 Allen	Coating
		Dmin	d	L	L1	f	h	kg								
K487	S20R DDUNL 11	30	20	200	50	13	18	0,508	TC046	TA013	TC034	BK024	BY041	BSP031	3 Allen	DNMG 1104
K488	S25S DDUNL 11	32	25	250	50	17	23	0,956	TC046	TA013	TC034	BK024	BY041	BSP031	3 Allen	ISO.
K490	S25S DDUNL 15	32	25	250	50	17	23	0,950	TC044	TA014-1	TC038	BK020	BY040	BSP030	3 Allen	DNMG
K492	S32T DDUNL 15	40	32	300	55	22	30	1,835	TC044	TA014-1	TC038	BK020	BY040	BSP030	3 Allen	1506
K494	S40T DDUNL 15	50	40	300	60	27	38	2,848	TC044	TA014-1	TC038	BK020	BY040	BSP030	3 Allen	ISO.
K495	S40U DDUNL 15	50	40	350	60	27	38	3,336	TC044	TA014-1	TC038	BK020	BY040	BSP030	3 Allen	
K496	S50U DDUNL 15	63	50	350	65	35	47	5,153	TC044	TA014-1	TC038	BK020	BY040	BSP030	3 Allen	

107,5° DDQNR

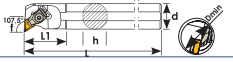
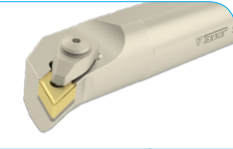

Order Code	Product Code	Dimensions (mm)							TC	TA	TC	BK	BY	BSP	3 Allen	Coating
		Dmin	d	L	L1	f	h	kg								
K476	S25S DDQNR 15	32	25	250	50	17	23	0,935	TC044	TA014-1	TC038	BK020	BY040	BSP030	3 Allen	DNMG
K477	S32T DDQNR 15	40	32	300	60	22	30	1,805	TC044	TA014-1	TC038	BK020	BY040	BSP030	3 Allen	1506
K478	S40T DDQNR 15	50	40	300	60	27	38	2,786	TC044	TA014-1	TC038	BK020	BY040	BSP030	3 Allen	ISO.
K479	S50U DDQNR 15	63	50	350	65	35	47	5,166	TC044	TA014-1	TC038	BK020	BY040	BSP030	3 Allen	

107,5° DDQNL

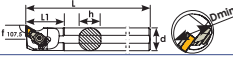
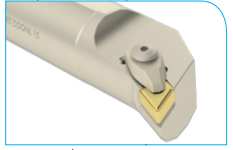

Order Code	Product Code	Dimensions (mm)							TC	TA	TC	BK	BY	BSP	3 Allen	Coating
		Dmin	d	L	L1	f	h	kg								
K533	S25S DDQNL 15	32	25	250	50	17	23	0,935	TC044	TA014-1	TC038	BK020	BY040	BSP030	3 Allen	
K534	S32T DDQNL 15	40	32	300	60	22	30	1,805	TC044	TA014-1	TC038	BK020	BY040	BSP030	3 Allen	DNMG 1506
K535	S40T DDQNL 15	50	40	300	60	27	38	2,786	TC044	TA014-1	TC038	BK020	BY040	BSP030	3 Allen	ISO.
K536	S50U DDQNL 15	63	50	350	65	35	47	5,166	TC044	TA014-1	TC038	BK020	BY040	BSP030	3 Allen	



93° MDUNR



Order Code	Product Code	Dimensions (mm)							kg	TC046	BSP021	BK017	BY041	3 Allen	DNMG 1104 ISO.
		Dmin	d	L	L1	f	h								
K408-1	S20R MDUNR 11	25	20	200	50	13	18	0,508							

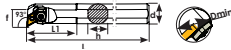

62,5° DDWNR

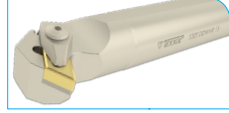

Order Code	Product Code	Dimensions (mm)							kg	TC044	TA014-1	TC038	BK020	BY040	BSP030	3 Allen	DNMG 1506 ISO.
		Dmin	d	L	L1	f	h										
K464	S32T DDWNR 15	40	32	300	55	24	30	1,859									
K466	S40T DDWNR 15	50	40	300	50	30	38	2,918									
K468	S50U DDWNR 15	63	50	350	60	35	47	5,298									

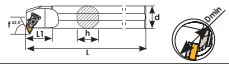

60° MTENR



Order Code	Product Code	Dimensions (mm)							kg	TC046	TA019	TC038	BK020	BY040	BSP030	3 Allen	TNMG 1604 ISO.
		Dmin	d	L	L1	f	h										
K456	S25S MTENR 16	32	25	250	55	17	23	0,960									
K458	S32T MTENR 16	40	32	300	60	22	30	1,842									
K460	S40T MTENR 16	50	40	300	60	27	38	2,802									
K462	S50U MTENR 16	63	50	350	70	35	47	5,125									

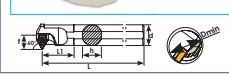

93° MTUNR

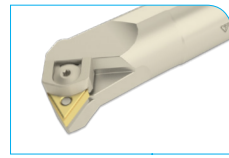

Order Code	Product Code	Dimensions (mm)							kg	TC043-1	TA019	BSP018	BK017-1	BY041	BSP031	3 Allen	TNMG 1604 ISO.
		Dmin	d	L	L1	f	h										
K441	S20R MTUNR 16	25	20	200	50	13	18	0,513									
K442	S25S MTUNR 16	32	25	250	50	17	23	0,952									
K444	S32T MTUNR 16	40	32	300	60	22	30	1,835									
K446	S40T MTUNR 16	50	40	300	60	27	38	2,852									
K448	S50U MTUNR 16	63	50	350	65	35	47	5,150									
K450	S32T MTUNR 22	40	32	300	60	22	30	1,836									
K452	S40T MTUNR 22	50	40	300	60	27	38	2,814									
K454	S50U MTUNR 22	63	50	350	65	35	47	5,145									

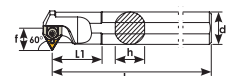

93° MTUNL

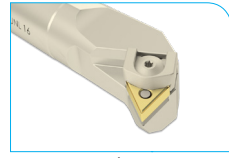

Order Code	Product Code	Dimensions (mm)							kg	TC043-1	TA019	BSP018	BK017-1	BY041	BSP031	3 Allen	TNMG 1604 ISO.
		Dmin	d	L	L1	f	h										
K519	S20R MTUNL 16	25	20	200	30	13	18	0,513									
K520	S25S MTUNL 16	32	25	250	50	17	23	0,952									
K522	S32T MTUNL 16	40	32	300	60	22	30	1,835									
K524	S40T MTUNL 16	50	40	300	60	27	38	2,852									
K526	S50U MTUNL 16	63	50	350	65	35	47	5,150									
K528	S32T MTUNL 22	40	32	300	60	22	30	1,836									
K530	S40T MTUNL 22	50	40	300	60	27	38	2,814									
K532	S50U MTUNL 22	63	50	350	65	35	47	5,145									

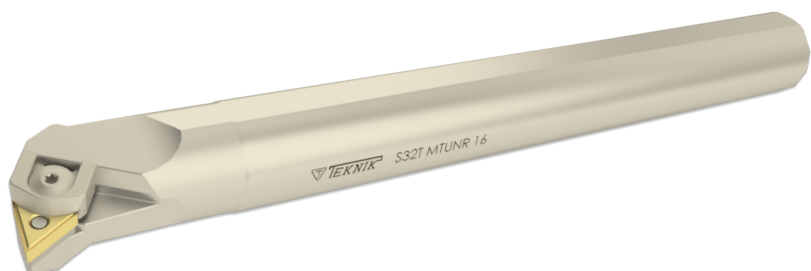
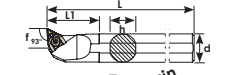

107,5° MTQNR	Order Code	Product Code	Dimensions (mm)														
			Dmin	d	L	L1	f	h									
	K365	S25S MTQNR 16	32	25	250	50	17	23	0,942	TC046	TA019	BSP020	BK022	BY043	BSP031	3 Allen	
	K366	S32T MTQNR 16	40	32	300	60	22	30	1,821	TC046	TA019	BSP020	BK022	BY043	BSP031	3 Allen	TNMG 1604
	K367	S40T MTQNR 16	50	40	300	60	27	38	2,807	TC046	TA019	BSP020	BK022	BY043	BSP031	3 Allen	ISO.
	K368	S50U MTQNR 16	63	50	350	65	35	47	5,121	TC046	TA019	BSP020	BK022	BY043	BSP031	3 Allen	

107,5° MTQNL	Order Code	Product Code	Dimensions (mm)														
			Dmin	d	L	L1	f	h									
	K537	S25S MTQNL 16	32	25	250	50	17	23	0,942	TC046	TA019	BSP020	BK022	BY043	BSP031	3 Allen	
	K538	S32T MTQNL 16	40	32	300	60	22	30	1,821	TC046	TA019	BSP020	BK022	BY043	BSP031	3 Allen	TNMG 1604
	K539	S40T MTQNL 16	50	40	300	60	27	38	2,807	TC046	TA019	BSP020	BK022	BY043	BSP031	3 Allen	ISO.
	K540	S50U MTQNL 16	63	50	350	65	35	47	5,121	TC046	TA019	BSP020	BK022	BY043	BSP031	3 Allen	

95° MWLNR	Order Code	Product Code	Dimensions (mm)														
			Dmin	d	L	L1	f	h									
	K427	S16Q MWLNR 06	21	16	180	40	11	15	0,286	TC046	--	BSP020	BK019	BY041	BSP031	3 Allen	WNMG 0604
	K427-1	S20R MWLNR 06	25	20	200	50	13	18	0,502	TC046	--	BSP020	BK019	BY041	BSP031	3 Allen	ISO.
	K428	S25S MWLNR 08	32	25	250	45	17	23	0,945	TC044	TA020	BSP021	BK026	BY040	BSP030	3 Allen	
	K430	S32T MWLNR 08	40	32	300	60	22	30	1,833	TC044	TA020	BSP021	BK026	BY040	BSP030	3 Allen	WNMG
	K432	S40T MWLNR 08	50	40	300	60	27	38	2,841	TC044	TA020	BSP021	BK026	BY040	BSP030	3 Allen	0804
	K434	S50U MWLNR 08	63	50	350	65	35	47	5,110	TC044	TA020	BSP021	BK026	BY040	BSP030	3 Allen	ISO.

95° MWLNL	Order Code	Product Code	Dimensions (mm)														
			Dmin	d	L	L1	f	h									
	K510	S25S MWLNL 08	32	25	250	45	17	23	0,945	TC044	TA020	BSP021	BK026	BY040	BSP030	3 Allen	WNMG
	K512	S32T MWLNL 08	40	32	300	60	22	30	1,833	TC044	TA020	BSP021	BK026	BY040	BSP030	3 Allen	0804
	K514	S40T MWLNL 08	50	40	300	60	27	38	2,841	TC044	TA020	BSP021	BK026	BY040	BSP030	3 Allen	ISO.
	K516	S50U MWLNL 08	63	50	350	65	35	47	5,110	TC044	TA020	BSP021	BK026	BY040	BSP030	3 Allen	

95° DWLNR	Order Code	Product Code	Dimensions (mm)														
			Dmin	d	L	L1	f	h									
	K418	S25S DWLNR 06	32	25	250	50	17	23	0,955	TC046	TA021	TC034	BK024	BY041	BSP031	3 Allen	WNMG 0604 ISO
	K420	S25S DWLNR 08	32	25	250	50	17	23	0,966	TC044	TA020-1	TC038	BK020	BY040	BSP030	3 Allen	
	K422	S32T DWLNR 08	40	32	300	60	22	30	1,837	TC044	TA020-1	TC038	BK020	BY040	BSP030	3 Allen	WNMG
	K424	S40T DWLNR 08	50	40	300	60	27	38	2,820	TC044	TA020-1	TC038	BK020	BY040	BSP030	3 Allen	0804
	K426	S50U DWLNR 08	63	50	350	75	35	47	5,123	TC044	TA020-1	TC038	BK020	BY040	BSP030	3 Allen	ISO.



**95° DWLNL**

Order Code	Product Code	Dimensions (mm)							TC	TA	TC	BK	BY	BSP	3 Allen	Material
		Dmin	d	L	L1	f	h	kg								
K498	S25S DWLNL 06	32	25	250	50	17	23	0,955	TC046	TA021	TC034	BK024	BY041	BSP031	3 Allen	WNMG 0604 ISO
K500	S25S DWLNL 08	32	25	250	50	17	23	0,966	TC044	TA020-1	TC038	BK020	BY040	BSP030	3 Allen	
K502	S32T DWLNL 08	40	32	300	60	22	30	1,837	TC044	TA020-1	TC038	BK020	BY040	BSP030	3 Allen	WNMG
K504	S40T DWLNL 08	50	40	300	60	27	38	2,820	TC044	TA020-1	TC038	BK020	BY040	BSP030	3 Allen	0804
K506	S50U DWLNL 08	63	50	350	75	35	47	5,123	TC044	TA020-1	TC038	BK020	BY040	BSP030	3 Allen	ISO.

**95° DCLNR**

Order Code	Product Code	Dimensions (mm)							TC	TA	TC	BK	BY	BSP	3 Allen	Material
		Dmin	d	L	L1	f	h	kg								
K400	S25S DCLNR 12	32	25	250	50	17	23	0,964	TC044	TA016-1	TC038	BK020	BY040	BSP030	3 Allen	
K402	S32T DCLNR 12	40	32	300	60	22	30	1,867	TC044	TA016-1	TC038	BK020	BY040	BSP030	3 Allen	CNMG 1204
K404	S40T DCLNR 12	50	40	300	60	27	38	2,845	TC044	TA016-1	TC038	BK020	BY040	BSP030	3 Allen	ISO.
K406	S50U DCLNR 12	63	50	350	60	35	47	5,166	TC044	TA016-1	TC038	BK020	BY040	BSP030	3 Allen	
K370	S32U DCLNR 16	40	32	350	60	22	30	2,272	TC044	TA022	TC095	BK018	BY040	BSP030	3 Allen	CNMG 1606
K371	S40U DCLNR 16	50	40	350	60	27	38	3,550	TC044	TA022	TC095	BK018	BY040	BSP030	3 Allen	ISO.
K374	S40U DCLNR 19	50	40	350	60	27	38	3,503	TC048	TA017	TC039	BK025	BY044	BSP032	3 Allen	CNMG 1906
K375	S50V DCLNR 19	63	50	400	60	35	47	6,333	TC048	TA017	TC039	BK025	BY044	BSP032	3 Allen	ISO.

**95° DCLNL**

Order Code	Product Code	Dimensions (mm)							TC	TA	TC	BK	BY	BSP	3 Allen	Material
		Dmin	d	L	L1	f	h	kg								
K480	S25S DCLNL 12	32	25	250	50	17	23	0,964	TC044	TA016-1	TC038	BK020	BY040	BSP030	3 Allen	
K482	S32T DCLNL 12	40	32	300	60	22	30	1,867	TC044	TA016-1	TC038	BK020	BY040	BSP030	3 Allen	CNMG 1204
K484	S40T DCLNL 12	50	40	300	60	27	38	2,845	TC044	TA016-1	TC038	BK020	BY040	BSP030	3 Allen	ISO.
K486	S50U DCLNL 12	63	60	350	75	35	47	5,166	TC044	TA016-1	TC038	BK020	BY040	BSP030	3 Allen	

**75° DCKNR**

Order Code	Product Code	Dimensions (mm)							TC	TA	TC	BK	BY	BSP	3 Allen	Material
		Dmin	d	L	L1	f	h	kg								
K401	S25S DCKNR 12	32	25	250	55	17	23	0,955	TC044	TA016-1	TC038	BK020	BY040	BSP030	3 Allen	
K403	S32T DCKNR 12	40	32	300	60	22	30	0,966	TC044	TA016-1	TC038	BK020	BY040	BSP030	3 Allen	CNMG 1204
K405	S40T DCKNR 12	50	40	300	65	27	38	1,837	TC044	TA016-1	TC038	BK020	BY040	BSP030	3 Allen	ISO.

**93° CKUNR**

Order Code	Product Code	Dimensions (mm)							TC	TA	TC	BK	BY	BSP	3 Allen	Material
		Dmin	d	L	L1	f	h	kg								
RK750	S25T CKUNR 16	32	25	300	52	19	23	1,400	TC044	TA048	TC036	BK030	BY042	BSP030	3 Allen	
RK754	S32U CKUNR 16	40	32	350	52	21	30	2,264	TC044	TA048	TC036	BK030	BY042	BSP030	3 Allen	KNUX 1604
RK756	S40V CKUNR 16	50	40	400	55	27	38	3,999	TC044	TA048	TC036	BK030	BY042	BSP030	3 Allen	ISO.
RK760	S50W CKUNR 16	63	50	450	60	35	47	0,408	TC044	TA048	TC036	BK030	BY042	BSP030	3 Allen	





**Uç Baglama Sistemleri**  
**Insert Clamping Systems**  
**Wendeplatten klem systems**



## A-S System Boring Bars

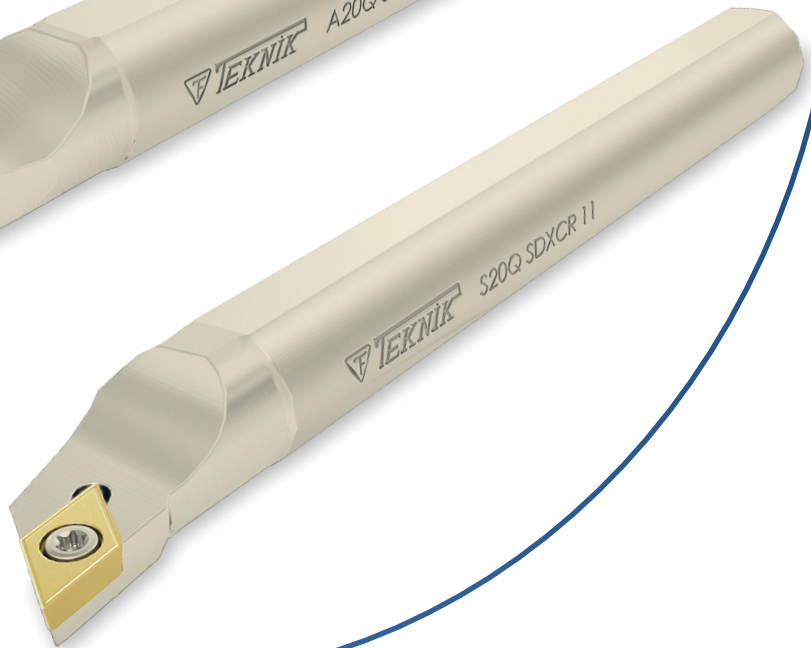
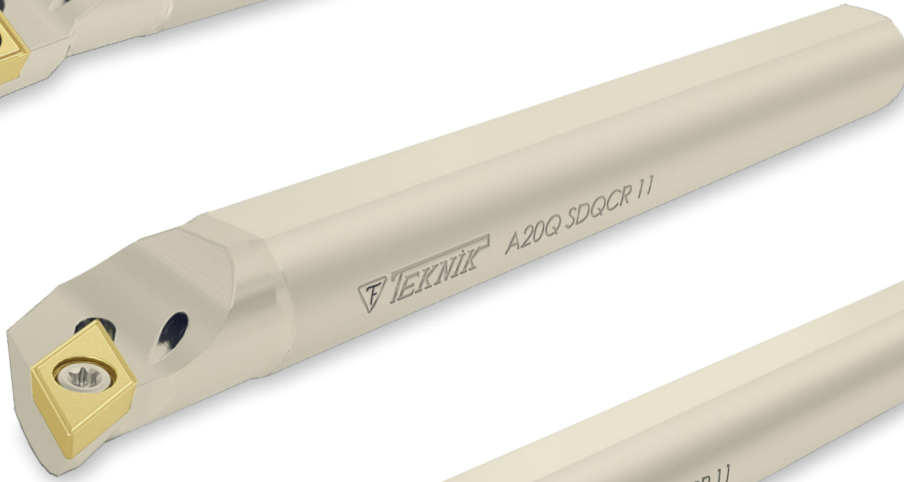
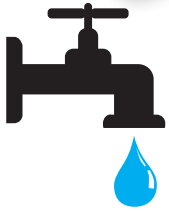

[www.teknikcuttingtools.com](http://www.teknikcuttingtools.com)



Kalite için TEKNİK çözüm  
Technical solution for quality

98-104



**95° SCLCR IC With Coolant**

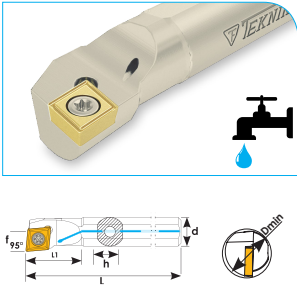

Order Code	Product Code	Dimensions (mm)							TC	T	ISO
		Dmin	d	L	L1	f	h	kg			
KA102	A08H SCLCR 06	10	8	100	16	5,5	7	0,050	TC060	T8	CCMT 0602
KA104	A10J SCLCR 06	12	10	110	20	6	9	0,074	TC060	T8	ISO.
KA106	A12K SCLCR 06	16	12	125	25	9	11	0,113	TC060	T8	
KA108	A14-16Q SCLCR 09	18	16	180	45	9,5	15	0,267	TC067	T15	CCMT 0903
KA110	A16Q SCLCR 09	20	16	180	30	11	15	0,260	TC067	T15	ISO.
KA111	A16M SCLCR 09	20	16	150	30	11	15	0,227	TC067	T15	
KA114	A20Q SCLCR 09	25	20	180	40	13	18	0,422	TC067	T15	
KA116	A25R SCLCR 09	32	25	200	40	17	23	0,734	TC067	T15	

**95° SCLCR**

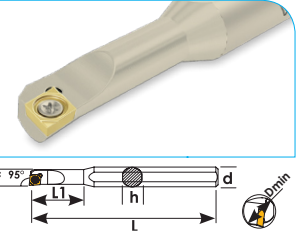

Order Code	Product Code	Dimensions (mm)							TC	T	ISO
		Dmin	d	L	L1	f	h	kg			
K097	S05-08H SCLCR 03	5	8	100	15	2,5	7,3	0,046	TC057	T6	CCMT 0301
K098	S06-08H SCLCR 03	6	8	100	18	3	7,3	0,048	TC057	T6	ISO.
K099	S07-08H SCLCR 04	7	8	100	21	3,5	7,3	0,050	TC058	T6	CCMT 0401 ISO.

**95° SCLCR**

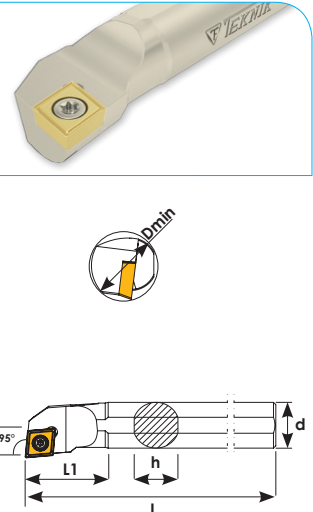

Order Code	Product Code	Dimensions (mm)							TC	T	ISO
		Dmin	d	L	L1	f	h	kg			
K100	S06-08H SCLCR 06	9	8	100	25	4,3	7,3	0,052	TC059-1	T8	
K102	S08H SCLCR 06	10	8	100	16	5,5	7,3	0,053	TC060	T8	CCMT 0602
K104	S10J SCLCR 06	12	10	110	20	6	9	0,080	TC060	T8	ISO.
K105	S10K SCLCR 06	12	10	125	20	6	9	0,085	TC060	T8	
K106	S12K SCLCR 06	16	12	125	25	9	11	0,120	TC060	T8	
K107	S12Q SCLCR 06	16	12	180	25	9	11	0,170	TC060	T8	
K107-1	S12K SCLCR 09	16	12	125	25	9	11	0,271	TC067	T15	
K108	S14-16Q SCLCR 09	18	16	180	45	9,5	15	0,285	TC067	T15	
K109	S16M SCLCR 09	20	16	150	30	11	15	0,228	TC067	T15	
K110	S16Q SCLCR 09	20	16	180	30	11	15	0,317	TC067	T15	
K111	S16R SCLCR 09	20	16	200	30	11	15	0,329	TC067	T15	CCMT 0903
K112	S18-20Q SCLCR 09	21	20	180	38	11	18	0,436	TC067	T15	ISO.
K114	S20Q SCLCR 09	25	20	180	40	13	18	0,612	TC067	T15	
K115	S20S SCLCR 09	25	20	250	40	13	18	0,780	TC067	T15	
K116	S25R SCLCR 09	32	25	200	40	17	23	0,694	TC067	T15	
K117	S25T SCLCR 09	32	25	300	40	17	23	1,165	TC067	T15	
K116-1	S25S SCLCR 12	32	25	250	45	17	23	0,965	TC083	T20	CCMT 1204 ISO.

**95° SCLCL IC With Coolant**

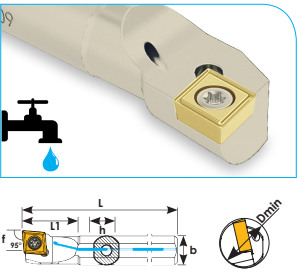

Order Code	Product Code	Dimensions (mm)							TC	T	ISO
		Dmin	d	L	L1	f	h	kg			
KA232	A08H SCLCL 06	10	8	100	16	5,5	7	0,050	TC060	T8	CCMT 0602
KA234	A10J SCLCL 06	12	10	110	20	6	9	0,074	TC060	T8	ISO.
KA236	A12K SCLCL 06	16	12	125	25	9	11	0,113	TC060	T8	
KA238	A14-16Q SCLCL 09	18	16	180	45	9,5	15	0,271	TC067	T15	
KA239	A16M SCLCL 09	20	16	150	30	11	15	0,227	TC067	T15	CCMT 0903
KA240	A16Q SCLCL 09	20	16	180	30	11	15	0,260	TC067	T15	ISO.
KA244	A20Q SCLCL 09	25	20	180	40	13	18	0,422	TC067	T15	
KA246	A25R SCLCL 09	32	25	200	40	17	23	0,734	TC067	T15	

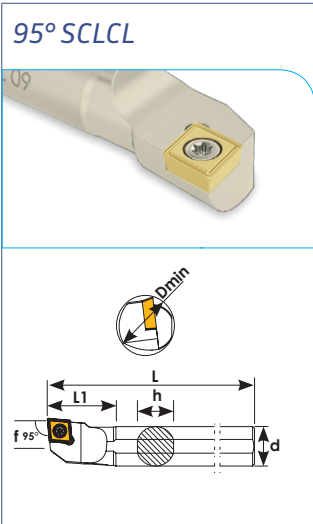

Order Code	Product Code	Dimensions (mm)							TC060	T8	ISO
		Dmin	d	L	L1	f	h	ISO			
K230	S06-08H SCLCL 06	9	8	100	25	4.3	7	0,052	TC060	T8	
K232	S08H SCLCL 06	10	8	100	16	5.5	7	0,053	TC060	T8	CCMT 0602
K233	S10K SCLCL 06	12	10	125	20	6	9	0,073	TC060	T8	ISO.
K234	S10J SCLCL 06	12	10	110	20	6	9	0,080	TC060	T8	
K235	S12Q SCLCL 06	16	12	180	25	9	11	0,145	TC060	T8	
K236	S12K SCLCL 06	16	12	125	25	9	11	0,120	TC060	T8	
K238	S14-16Q SCLCL 09	18	16	180	45	9,5	15	0,271	TC067	T15	
K239	S16M SCLCL 09	20	16	150	30	11	15	0,228	TC067	T15	
K240	S16Q SCLCL 09	20	16	180	30	11	15	0,285	TC067	T15	CCMT 0903
K241	S16R SCLCL 09	20	16	200	30	11	15	0,317	TC067	T15	ISO.
K244	S20Q SCLCL 09	25	20	180	40	13	18	0,436	TC067	T15	
K245	S20S SCLCL 09	25	20	250	40	13	18	0,612	TC067	T15	
K246	S25R SCLCL 09	32	25	200	40	17	23	0,780	TC067	T15	

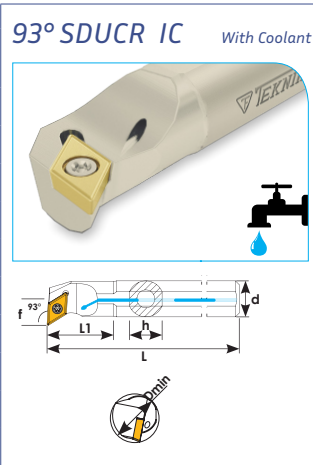

Order Code	Product Code	Dimensions (mm)							TC060	T8	DCMT
		Dmin	d	L	L1	f	h	ISO			
KA120	A10J SDUCR 07	12	10	110	20	7	9	0,080	TC060	T8	
KA122	A12K SDUCR 07	16	12	125	25	9	11	0,120	TC060	T8	DCMT 0702
KA124	A14-16Q SDUCR 07	18	16	180	40	10,5	15	0,267	TC060	T8	ISO.
KA126	A16Q SDUCR 07	20	16	180	30	11	15	0,263	TC060	T8	
KA127	A16M SDUCR 07	20	16	150	30	11	15	0,250	TC060	T8	
KA128	A16Q SDUCR 11	20	16	180	30	11	15	0,285	TC067	T15	
KA129	A16M SDUCR 11	20	16	150	30	11	15	0,246	TC067	T15	DCMT 11T3
KA130	A20Q SDUCR 11	25	20	180	32	13	18	0,432	TC067	T15	ISO.
KA132	A25R SDUCR 11	32	25	200	40	17	23	0,746	TC067	T15	
KA134	A32T SDUCR 11	40	32	300	45	22	30	1,924	TC067	T15	

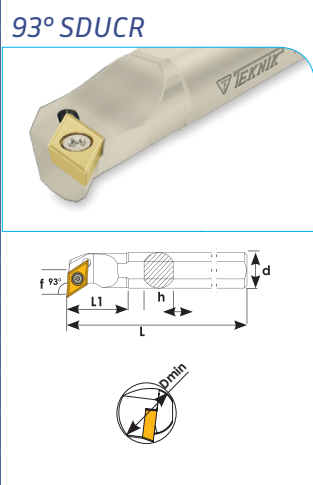

Order Code	Product Code	Dimensions (mm)							TC060	T8	DCMT
		Dmin	d	L	L1	f	h	ISO			
K120	S10J SDUCR 07	12	10	110	20	7	9	0,080	TC060	T8	
K122	S12K SDUCR 07	16	12	125	25	9	11	0,120	TC060	T8	DCMT 0702
K123	S12Q SDUCR 07	16	12	180	25	9	11	0,170	TC060	T8	ISO.
K124	S14-16Q SDUCR 07	18	16	180	40	10,5	15	0,266	TC060	T8	
K126	S16Q SDUCR 07	20	16	180	30	11	15	0,292	TC060	T8	
K125	S14-16Q SDUCR 11	18	16	180	45	10,5	15	0,272	TC067	T15	
K128	S16Q SDUCR 11	20	16	180	30	11,5	15	0,285	TC067	T15	DCMT 11T3
K129	S16M SDUCR 11	20	16	150	30	11	15	0,246	TC067	T15	ISO.
K130	S20Q SDUCR 11	25	20	180	32	13	18	0,435	TC067	T15	
K132	S25R SDUCR 11	32	25	200	40	17	23	0,748	TC067	T15	
K134	S32T SDUCR 11	40	32	300	45	22	30	1,833	TC067	T15	

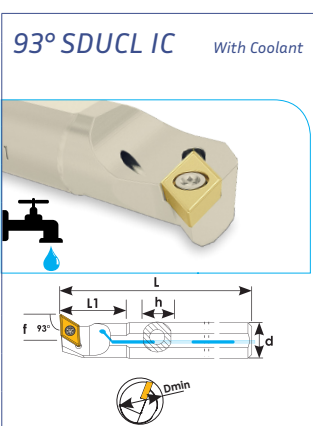

Order Code	Product Code	Dimensions (mm)							TC060	T8	DCMT
		Dmin	d	L	L1	f	h	ISO			
KA250	A10J SDUCL 07	12	10	110	20	7	9	0,080	TC060	T8	DCMT 0702
KA252	A12K SDUCL 07	16	12	125	25	9	11	0,120	TC060	T8	ISO.
KA254	A14-16Q SDUCL 07	18	16	180	40	10,5	15	0,267	TC060	T8	
KA256	A16Q SDUCL 07	20	16	180	30	11	15	0,263	TC060	T8	
KA258	A16Q SDUCL 11	20	16	180	30	11	15	0,285	TC067	T15	
KA259	A16M SDUCL 11	20	16	150	30	11	15	0,246	TC067	T15	DCMT 11T3
KA260	A20Q SDUCL 11	25	20	180	32	13	18	0,432	TC067	T15	ISO.
KA262	A25R SDUCL 11	32	25	200	40	17	23	0,746	TC067	T15	
KA263	A32T SDUCL 11	40	32	300	45	22	30	1,924	TC067	T15	

### 93° SDUCL

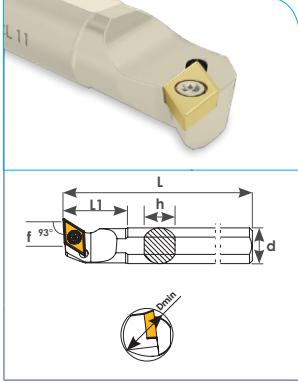

Order Code	Product Code	Dimensions (mm)							kg	TC	T	ISO
		Dmin	d	L	L1	f	h					
K250	S10J SDUCL 07	12	10	110	20	7	9	0,080	TC060	T8		
K252	S12K SDUCL 07	16	12	125	25	9	11	0,120	TC060	T8	DCMT 0702	
K254	S14-16Q SDUCL 07	18	16	180	40	10,5	15	0,266	TC060	T8	ISO.	
K256	S16Q SDUCL 07	20	16	180	30	11	15	0,292	TC060	T8		
K258	S16Q SDUCL 11	20	16	180	30	11	15	0,285	TC067	T15	DCMT 11T3	
K259	S16M SDUCL 11	20	16	150	30	11	15	0,246	TC067	T15		
K260	S20Q SDUCL 11	25	20	180	32	13	18	0,435	TC067	T15	ISO.	
K262	S25R SDUCL 11	32	25	200	40	17	23	0,748	TC067	T15		
K263	S32T SDUCL 11	40	32	300	45	22	30	1,833	TC067	T15		

### 107,5° SDQCR IC With Coolant



Order Code	Product Code	Dimensions (mm)							kg	TC	T	ISO
		Dmin	d	L	L1	f	h					
KA140	A10J SDQCR 07	12	10	110	20	7	9	0,074	TC060	T8	DCMT 0702	
KA142	A12K SDQCR 07	16	12	125	25	9	11	0,110	TC060	T8	ISO.	
KA143	A16M SDQCR 07	20	16	150	30	11	15	0,232	TC060	T8		
KA144	A16Q SDQCR 07	20	16	180	30	11	15	0,282	TC060	T8		
KA146	A16Q SDQCR 11	20	16	180	32	11	15	0,275	TC067	T15		
KA148	A20Q SDQCR 11	25	20	180	32	13	18	0,425	TC067	T15	DCMT 11T3	
KA150	A25R SDQCR 11	32	25	200	40	17	23	0,738	TC067	T15	ISO.	

### 107,5° SDQCR

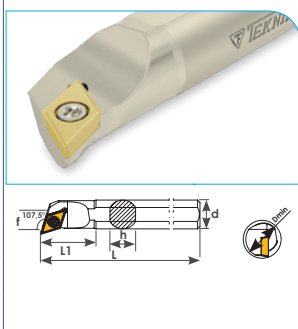

Order Code	Product Code	Dimensions (mm)							kg	TC	T	ISO
		Dmin	d	L	L1	f	h					
K140	S10J SDQCR 07	12	10	110	20	7	9	0,080	TC060	T8	DCMT 0702	
K142	S12K SDQCR 07	16	12	125	25	9	11	0,120	TC060	T8	ISO.	
K144	S16Q SDQCR 07	20	16	180	30	11	15	0,292	TC060	T8		
K146	S16Q SDQCR 11	20	16	180	32	11	15	0,285	TC067	T15		
K148	S20Q SDQCR 11	25	20	180	32	13	18	0,435	TC067	T15	DCMT 11T3	
K150	S25R SDQCR 11	32	25	200	40	17	23	0,748	TC067	T15	ISO.	
K152	S32T SDQCR 11	40	32	300	50	22	30	1,833	TC067	T15		
K154	S40T SDQCR 11	50	40	300	50	27	38	0,268	TC067	T15		

### 107,5° SDQCL IC With Coolant

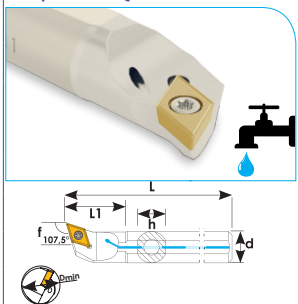

Order Code	Product Code	Dimensions (mm)							kg	TC	T	ISO
		Dmin	d	L	L1	f	h					
KA270	A10J SDQCL 07	12	10	110	20	7	9	0,074	TC060	T8	DCMT 0702	
KA272	A12K SDQCL 07	16	12	125	25	9	11	0,110	TC060	T8	ISO.	
KA273	A16M SDQCL 07	20	16	150	30	11	15	0,232	TC060	T8		
KA274	A16Q SDQCL 07	20	16	180	30	11	15	0,282	TC060	T8		
KA276	A16Q SDQCL 11	20	16	180	30	11	15	0,275	TC067	T15	DCMT 11T3	
KA278	A20Q SDQCL 11	25	20	180	32	13	18	0,425	TC067	T15	ISO.	
KA280	A25R SDQCL 11	32	25	200	40	17	23	0,738	TC067	T15		

### 107,5° SDQCL



Order Code	Product Code	Dimensions (mm)							kg	TC	T	ISO
		Dmin	d	L	L1	f	h					
K270	S10J SDQCL 07	12	10	110	20	7	9	0,080	TC060	T8	DCMT 0702	
K272	S12K SDQCL 07	16	12	125	25	9	11	0,120	TC060	T8	ISO.	
K274	S16Q SDQCL 07	20	16	180	30	11	15	0,292	TC060	T8		
K276	S16Q SDQCL 11	20	16	180	30	11	15	0,285	TC067	T15		
K278	S20Q SDQCL 11	25	20	180	32	13	18	0,435	TC067	T15	DCMT 11T3	
K280	S25R SDQCL 11	32	25	200	40	17	23	0,748	TC067	T15	ISO.	
K281	S32T SDQCL 11	40	32	300	50	22	30	1,833	TC067	T15		

120° SDXCR	Order Code	Product Code	Dimensions (mm)									
			Dmin	d	L	L1	f	h	kg			
 	K469	S10J SDXCR 07	12	10	110	25	5,5	9	0,080	TC060	T8	DCMT 0702
	K470	S12K SDXCR 07	16	12	125	30	9	11	0,120	TC060	T8	ISO.
	K471	S16Q SDXCR 11	20	16	180	40	11	15	0,285	TC067	T15	
	K472	S20Q SDXCR 11	25	20	180	40	13	18	0,435	TC067	T15	
	K473	S25R SDXCR 11	32	25	200	50	13,5	23	0,748	TC067	T15	DCMT 11T3
	K474	S32T SDXCR 11	40	32	300	55	17	30	1,833	TC067	T15	ISO.
	K475	S40T SDXCR 11	50	40	300	55	21	38	0,268	TC067	T15	

62,5° SD-CR	Order Code	Product Code	Dimensions (mm)									
			Dmin	d	L	L1	f	h	kg			
 	K168	S10J SD-CR 07	14	10	110	25	8,2	9	0,082	TC060	T8	DCMT 0702
	K170	S12K SD-CR 07	16	12	125	25	9	11	0,122	TC060	T8	ISO.
	K173	S16Q SD-CR 07	20	16	180	35	12	15	0,280	TC060	T8	
	K172	S16Q SD-CR 11	23	16	180	35	14	15	0,288	TC067	T15	
	K174	S20Q SD-CR 11	25	20	180	32	15	18	0,443	TC067	T15	DCMT 11T3
	K176	S25R SD-CR 11	32	25	200	35	17	23	0,771	TC067	T15	ISO.
	K178	S32T SD-CR 11	40	32	300	55	23	30	1,865	TC067	T15	

5° SDZCR	Order Code	Product Code	Dimensions (mm)									
			Dmin	d	L	L1	f	h	kg			
 	K190	S12K SDZCR 07	18	12	125	20	11	11	0,128	TC060	T8	DCMT 0702 ISO
	K192	S16Q SDZCR 11	23	16	180	25	14	15	0,302	TC067	T16	
	K194	S20Q SDZCR 11	30	20	180	32	19	18	0,498	TC067	T16	DCMT 11T3
	K196	S25R SDZCR 11	35	25	200	32	22	23	0,816	TC067	T16	ISO

60° ST-CR	Order Code	Product Code	Dimensions (mm)									
			Dmin	d	L	L1	f	h	kg			
 	K180	S16Q ST-CR 16	20	16	180	40	11	15	0,817	TC067	T15	TCMT 16T3
	K182	S20Q ST-CR 16	25	20	180	40	13	18	0,432	TC067	T15	ISO
	K183	S25R ST-CR 16	32	25	200	50	17	23	0,772	TC067	T15	
	K183-1	S32T ST-CR 16	30	32	300	60	22	30	1,961	TC067	T15	

90° STFCR IC <small>With Coolant</small>	Order Code	Product Code	Dimensions (mm)									
			Dmin	d	L	L1	f	h	kg			
 	KA160	A12K STFCR 11	16	12	125	25	9	11	0,053	TC060	T8	TCMT 1102
	KA161	A16Q STFCR 11	20	16	180	30	11	15	0,289	TC060	T8	ISO.
	KA162	A16Q STFCR 16	20	16	180	30	11	15	0,287	TC067	T16	
	KA164	A20Q STFCR 16	25	20	180	32	13	18	0,440	TC067	T16	TCMT 16T3
	KA166	A25R STFCR 16	32	25	200	40	16	23	0,754	TC067	T16	ISO.

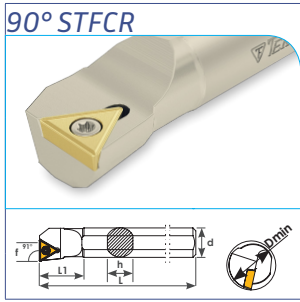

Order Code	Product Code	Dimensions (mm)									
		Dmin	d	L	L1	f	h				
K160	S12K STFCR 11	16	12	125	25	9	11	0,118	TC060	T8	TCMT 1102
K161	S16Q STFCR 11	20	16	180	30	11	15	0,290	TC060	T8	ISO.
K162	S16Q STFCR 16	20	16	180	30	11	15	0,287	TC067	T15	TCMT 16T3
K164	S20Q STFCR 16	25	20	180	32	13	18	0,440	TC067	T15	ISO.
K166	S25R STFCR 16	32	25	200	40	16	23	0,773	TC067	T15	

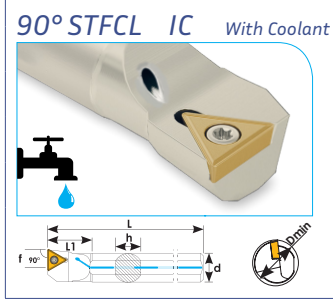

Order Code	Product Code	Dimensions (mm)									
		Dmin	d	L	L1	f	h				
KA184	A12K STFCL 11	16	12	125	25	9	11	0,053	TC060	T8	TCMT 1102
KA185	A16Q STFCL 11	20	16	180	30	11	15	0,289	TC060	T8	ISO.
KA186	A16Q STFCL 16	20	16	180	30	11	15	0,287	TC067	T16	
KA187	A20Q STFCL 16	25	20	180	32	13	18	0,440	TC067	T16	TCMT 16T3
KA188	A25R STFCL 16	32	25	200	40	16	23	0,754	TC067	T16	ISO.

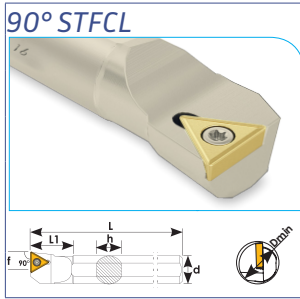

Order Code	Product Code	Dimensions (mm)									
		Dmin	d	L	L1	f	h				
K184	S12K STFCL 11	16	12	125	25	9	11	0,118	TC060	T8	TCMT 1102
K185	S16Q STFCL 11	20	16	180	30	11	15	0,290	TC060	T8	ISO.
K186	S16Q STFCL 16	20	16	180	30	11	15	0,287	TC067	T15	
K187	S20Q STFCL 16	25	20	180	32	13	18	0,440	TC067	T15	TCMT 16T3
K188	S25R STFCL 16	32	25	200	40	16	23	0,773	TC067	T15	ISO.



Order Code	Product Code	Dimensions (mm)									
		Dmin	d	L	L1	f	h				
KA206	A16Q SVUBR 11	20	16	180	30	11	15	0,275	TC061	T8	VBMT 1103
KA207	A20Q SVUBR 11	25	20	180	32	13	18	0,697	TC061	T8	ISO.
KA208	A25R SVUBR 16	32	25	200	40	17	23	0,723	TC074	T15	VBMT 1604
KA209	A32T SVUBR 16	40	32	300	50	22	30	1,909	TC074	T15	ISO.

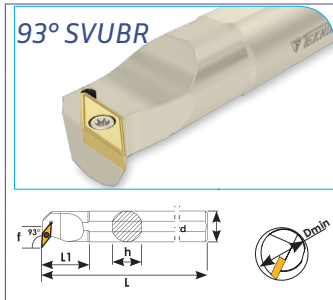

Order Code	Product Code	Dimensions (mm)									
		Dmin	d	L	L1	f	h				
K206	S16Q SVUBR 11	20	16	180	30	11	15	0,278	TC061	T8	VBMT 1103
K207	S20Q SVUBR 11	25	20	180	32	13	18	0,700	TC061	T8	ISO.
K208	S25R SVUBR 16	32	25	200	40	17	23	0,730	TC074	T15	
K209	S32T SVUBR 16	40	32	300	50	22	30	1,822	TC074	T15	VBMT 1604
K210	S40T SVUBR 16	50	40	300	50	27	38	2,836	TC074	T15	ISO.

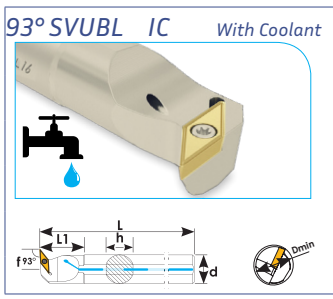

Order Code	Product Code	Dimensions (mm)									
		Dmin	d	L	L1	f	h				
KA282	A16Q SVUBL 11	20	16	180	30	11	15	0,278	TC061	T8	VBMT 1103
KA284	A20Q SVUBL 11	25	20	180	32	13	18	0,700	TC061	T8	ISO.
KA286	A25R SVUBL 16	32	25	200	40	17	23	0,723	TC074	T15	VBMT 1604
KA288	A32T SVUBL 16	40	32	300	50	22	30	1,909	TC074	T15	ISO.

**93° SVUBL**

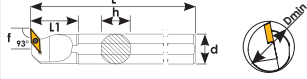
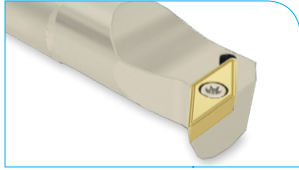

Order Code	Product Code	Dimensions (mm)									
		Dmin	d	L	L1	f	h				
K282	S16Q SVUBL 11	20	16	180	30	11	15	0,278	TC061	T8	VBMT 1103
K284	S20Q SVUBL 11	25	20	180	32	13	18	0,700	TC061	T8	ISO.
K286	S25R SVUBL 16	32	25	200	40	17	23	0,730	TC074	T15	VBMT 1604
K288	S32T SVUBL 16	40	32	300	50	22	30	1,822	TC074	T15	ISO.

**93° SVUCR IC**

With Coolant

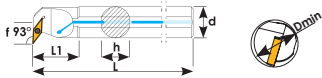
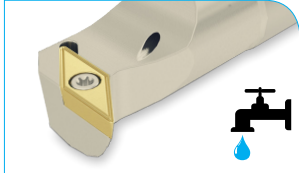

Order Code	Product Code	Dimensions (mm)									
		Dmin	d	L	L1	f	h				
KA211	A16Q SVUCR 11	20	16	180	30	11	15	0,268	TC061	T8	VCMT 1103
KA212	A20Q SVUCR 11	25	20	180	32	13	18	0,689	TC061	T8	ISO.
KA213	A25R SVUCR 16	32	25	200	40	17	23	0,720	KA213-KA214	T15	VCMT 1604
KA214	A32T SVUCR 16	40	32	300	50	22	30	1,812	KA213-KA214	T15	ISO.

**93° SVUCR**

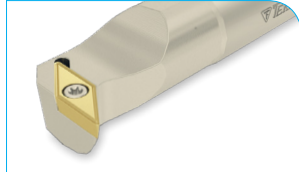

Order Code	Product Code	Dimensions (mm)									
		Dmin	d	L	L1	f	h				
K211	S16Q SVUCR 11	20	16	180	30	11	15	0,280	TC061	T8	VCMT 1103
K212	S20Q SVUCR 11	25	20	180	32	13	18	0,432	TC061	T8	ISO.
K213	S25R SVUCR 16	32	25	200	40	17	23	0,771	TC074	T15	
K214	S32T SVUCR 16	40	32	300	50	22	30	1,833	TC074	T15	VCMT 1604
K215	S40T SVUCR 16	50	40	300	55	27	38	2,807	TC074	T15	ISO.

**93° SVUCL IC**

With Coolant

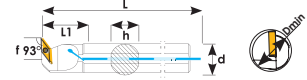
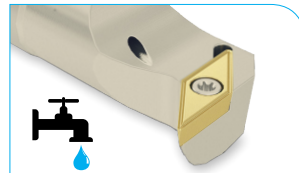

Order Code	Product Code	Dimensions (mm)									
		Dmin	d	L	L1	f	h				
KA300	A16Q SVUCL 11	20	16	180	30	11	15	0,268	TC061	T8	VCMT 1103
KA302	A20Q SVUCL 11	25	20	180	32	13	18	0,689	TC061	T8	ISO.
KA304	A25R SVUCL 16	32	25	200	40	17	23	0,720	TC074	T15	VCMT 1604
KA306	A32T SVUCL 16	40	32	300	50	22	30	1,812	TC074	T15	ISO.

**SVUCL**

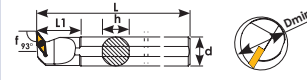
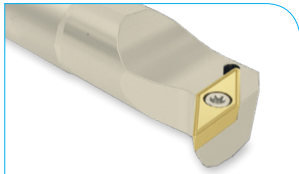

Order Code	Product Code	Dimensions (mm)									
		Dmin	d	L	L1	f	h				
K300	S16Q SVUCL 11	20	16	180	30	11	15	0,280	TC061	T8	VCMT 1103
K302	S20Q SVUCL 11	25	20	180	32	13	18	0,432	TC061	T8	ISO.
K304	S25R SVUCL 16	32	25	200	40	17	23	0,771	TC074	T15	VCMT 1604
K306	S32T SVUCL 16	40	32	300	50	22	30	1,833	TC074	T15	ISO.

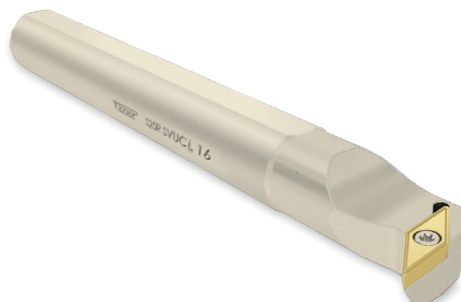

**107,5° SVQCR IC** With Coolant

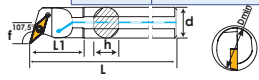

Order Code	Product Code	Dimensions (mm)							kg			
		Dmin	d	L	L1	f	h					
KA221	A16Q SVQCR 11	20	16	180	30	11	15	0,271	TC061	T8	VCMT 1103	
KA222	A20Q SVQCR 11	25	20	180	30	13	18	1,752	TC061	T8	ISO.	

**107,5° SVQCR**

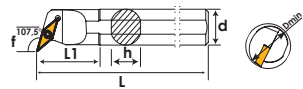
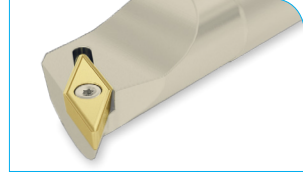

Order Code	Product Code	Dimensions (mm)							kg			
		Dmin	d	L	L1	f	h					
K221	S16Q SVQCR 11	20	16	180	30	11	15	0,281	TC061	T8	VCMT 1103	
K222	S20Q SVQCR 11	25	20	180	30	13	18	1,762	TC061	T8	ISO.	
K223	S25R SVQCR 16	32	25	200	50	17	23	0,728	TC074	T15		
K224	S32T SVQCR 16	40	32	300	50	22	30	1,786	TC074	T15	VCMT 1604	
K225	S40T SVQCR 16	50	40	300	55	27	38		TC074	T15	ISO.	

**107,5° SVQCL IC** With Coolant

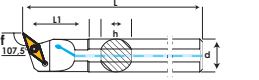

Order Code	Product Code	Dimensions (mm)							kg			
		Dmin	d	L	L1	f	h					
KA319	A16Q SVQCL 11	20	16	180	30	11	15	0,271	TC061	T8	VCMT 1103	
KA320	A20Q SVQCL 11	25	20	180	30	13	18	1,752	TC061	T8	ISO.	

**107,5° SVQCL**

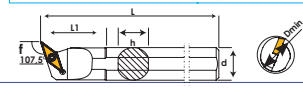

Order Code	Product Code	Dimensions (mm)							kg			
		Dmin	d	L	L1	f	h					
K319	S16Q SVQCL 11	20	16	180	30	11	15	0,281	TC061	T8	VCMT 1103	
K320	S20Q SVQCL 11	25	20	180	30	13	18	0,430	TC061	T8	ISO.	
K322	S25R SVQCL 16	32	25	200	50	17	23	0,728	TC074	T15	VCMT 1604	
K324	S32T SVQCL 16	40	32	300	50	22	30	0,725	TC074	T15	ISO.	

**107,5° SVQBR**

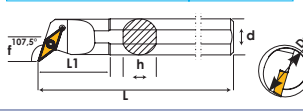
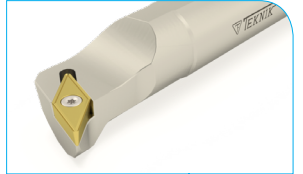

Order Code	Product Code	Dimensions (mm)							kg			
		Dmin	d	L	L1	f	h					
K216	S16Q SVQBR 11	20	16	180	30	11	15	0,276	TC061	T8	VBMT 1103	
K217	S20Q SVQBR 11	25	20	180	30	13	18	0,422	TC061	T8	ISO.	
K218	S25R SVQBR 16	32	25	200	50	17	23	0,725	TC074	T15		
K219	S32T SVQBR 16	40	32	300	50	22	30	1,790	TC074	T15	VBMT 1604	
K220	S40T SVQBR 16	50	40	300	55	27	38	2,765	TC074	T15	ISO.	

**107,5° SVQBL**

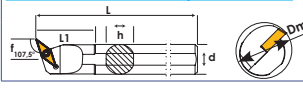
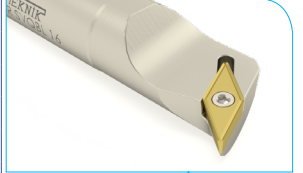

Order Code	Product Code	Dimensions (mm)							kg			
		Dmin	d	L	L1	f	h					
K310	S16Q SVQBL 11	20	16	180	30	11	15	0,276	TC061	T8	VBMT 1103	
K312	S20Q SVQBL 11	25	20	180	30	13	18	0,422	TC061	T8	ISO.	
K314	S25R SVQBL 16	32	25	200	50	17	23	0,725	TC074	T15		
K316	S32T SVQBL 16	40	32	300	50	22	30	1,790	TC074	T15	VBMT 1604	
K318	S40T SVQBL 16	50	40	300	55	27	38	2,765	TC074	T15	ISO.	

## Carbide Boring Bars / Set

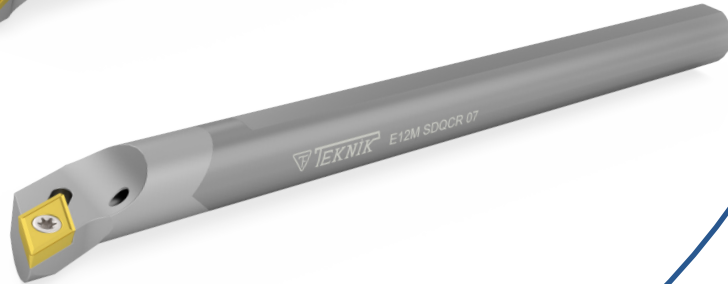
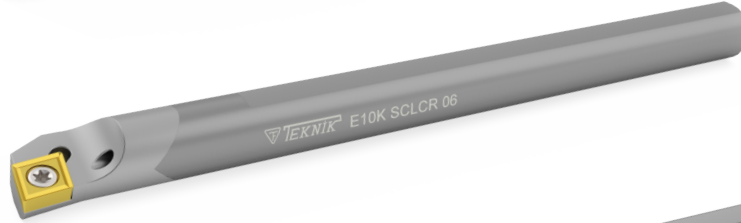
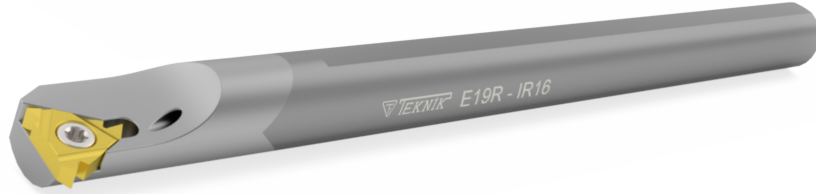
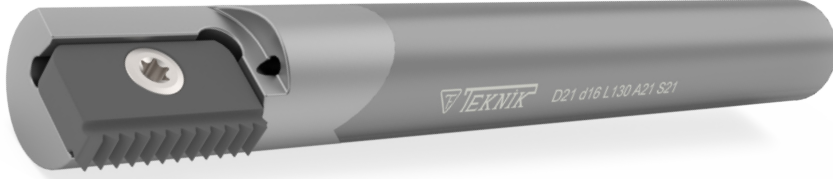
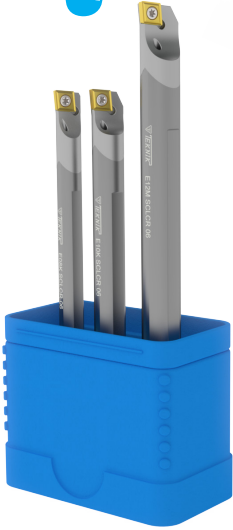

[www.teknikcuttingtools.com](http://www.teknikcuttingtools.com)



Kalite için TEKNİK çözüm



Technical solution for quality

106-108







*E-SCLCR SET*



Order Code	Product Code in Set	
iPS30 	E08K SCLCR 06	CCMT 0602
	E10K SCLCR 06	ISO.
	E12M SCLCR 06	

*E-SCLCL SET*

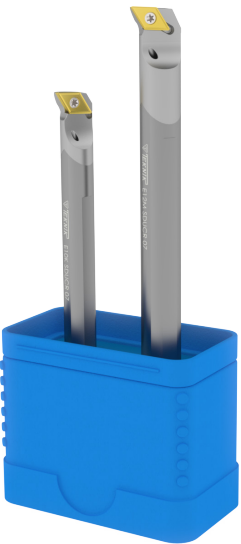

Order Code	Product Code in Set	
iPS31 	E08K SCLCL 06	CCMT 0602
	E10K SCLCL 06	ISO.
	E12M SCLCL 06	



*E-SDUCR SET*



Order Code	Product Code in Set	
iPS32 	E10K SDUCR 07	DCMT 0702
	E12M SDUCR 07	ISO.

*E-SDUCL SET*



Order Code	Product Code in Set	
iPS33 	E10K SDUCL 07	DCMT 0702
	E12M SDUCL 07	ISO.



*E-SDQCR SET*

Order Code	Product Code in Set	
iPS34 	E10K SDQCR 07	DCMT 0702
	E12M SDQCR 07	ISO.

*E-SDQCL SET*

Order Code	Product Code in Set	
iPS35 	E10K SDQCL 07	DCMT 0702
	E12M SDQCL 07	ISO.

95° E-SCLCR IC	Order Code	Product Code	Dimensions (mm)					TC	TC	ISO	
			Dmin	d	L	f	h				
	KE10	E08K SCLCR 06	10	8	125	5	7,5	0,050	TC060	T8	CCMT 0602
	KE11	E10K SCLCR 06	12	10	125	6	9,5	0,100	TC060	T8	ISO.
	KE12	E12M SCLCR 06	16	12	150	7	11,5	0,200	TC060	T8	
	KE13	E16R SCLCR 09	20	16	200	10	15,5	0,500	TC067	T15	CCMT 0903
	KE14	E20S SCLCR 09	25	20	250	13	19,5	0,950	TC067	T15	ISO

95° E-SCLCL IC	Order Code	Product Code	Dimensions (mm)					TC	TC	ISO	
			Dmin	d	L	f	h				
	KE17	E08K SCLCL 06	10	8	125	5	7,5	0,050	TC060	T8	CCMT 0602
	KE18	E10K SCLCL 06	12	10	125	6	9,5	0,100	TC060	T8	ISO.
	KE19	E12M SCLCL 06	16	12	150	7	11,5	0,200	TC060	T8	
	KE20	E16R SCLCL 09	20	16	200	10	15,5	0,500	TC067	T15	CCMT 0903
	KE21	E20S SCLCL 09	25	20	250	13	19,5	0,950	TC067	T15	ISO

93° E-SDUCR IC	Order Code	Product Code	Dimensions (mm)					TC	TC	ISO	
			Dmin	d	L	f	h				
	KE30	E10K SDUCR 07	13	10	125	7	9,5	0,050	TC060	T8	DCMT 0702
	KE31	E12M SDUCR 07	16	12	150	9	11,5	0,100	TC060	T8	ISO.
	KE32	E16R SDUCR 07	20	16	200	11	15,5	0,200	TC060	T8	
	KE33	E16R SDUCR 11	20	16	200	11	15,5	0,500	TC067	T15	DCMT 11T3
	KE34	E20S SDUCR 11	25	20	250	13	19,5	0,950	TC067	T15	ISO

93° E-SDUCL IC	Order Code	Product Code	Dimensions (mm)					TC	TC	ISO	
			Dmin	d	L	f	h				
	KE40	E10K SDUCL 07	13	10	125	7	9,5	0,050	TC060	T8	DCMT 0702
	KE41	E12M SDUCL 07	16	12	150	9	11,5	0,100	TC060	T8	ISO.
	KE42	E16R SDUCL 07	20	16	200	11	15,5	0,200	TC060	T8	
	KE43	E16R SDUCL 11	20	16	200	11	15,5	0,500	TC067	T15	DCMT 11T3
	KE44	E20S SDUCL 11	25	20	250	13	19,5	0,950	TC067	T15	ISO

107,5° E-SDQCR IC

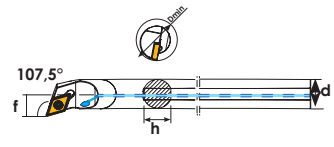
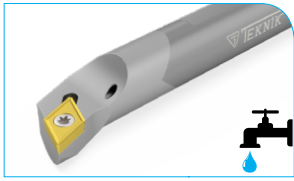

Order Code	Product Code	Dimensions (mm)									
		Dmin	d	L	f	h					
KE50	E10K SDQCR 07	13	10	125	7	9,5	0,050	TC060	T8	DCMT 0702	
KE51	E12M SDQCR 07	16	12	150	9	11,5	0,100	TC060	T8	ISO.	
KE52	E16R SDQCR 07	20	16	200	11	15,5	0,200	TC060	T8		
KE53	E16R SDQCR 11	20	16	200	11	15,5	0,500	TC067	T15	DCMT 11T3	
KE54	E20S SDQCR 11	25	20	250	13	19,5	0,950	TC067	T15	ISO	

107,5° E-SDQCL IC

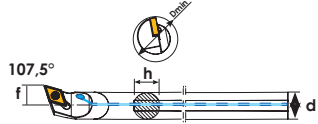
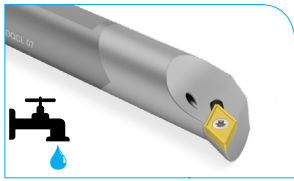

Order Code	Product Code	Dimensions (mm)									
		Dmin	d	L	f	h					
KE60	E10K SDQCL 07	13	10	125	7	9,5	0,050	TC060	T8	DCMT 0702	
KE61	E12M SDQCL 07	16	12	150	9	11,5	0,100	TC060	T8	ISO.	
KE62	E16R SDQCL 07	20	16	200	11	15,5	0,200	TC060	T8		
KE63	E16R SDQCL 11	20	16	200	11	15,5	0,500	TC067	T15	DCMT 11T3	
KE64	E20S SDQCL 11	25	20	250	13	19,5	0,950	TC067	T15	ISO	

Carbide Internal Threading Holder/R With Coolant

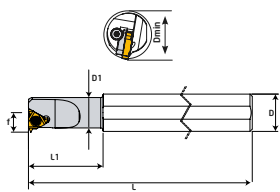
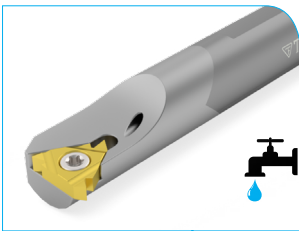

Order Code	Product Code	Dimensions (mm)												
		D	L	L1	f	Dmin								
KE70	E06H - IR06	6	100	26	4,3	6	0,024	TC058-1	-	-	-	T6	6 IR	
KE71	E08K - IR08	8	125	31	5,3	7,8	0,045	TC058	-	-	-	T6	8 IR	
KE72	E10K - IR11	10	125	-	7,4	12	0,085	TC060	-	-	-	T8	11 IR	
KE73	E12M - IR11	12	150	-	8,4	15	0,150	TC060	-	-	-	T8	11 IR	
KE74	E16R - IR16	16	200	-	11,7	19	0,260	TC067	-	-	-	T15	16 IR	
KE75	E20S - IR16	20	250	-	13,7	24	0,560	TC068	TA060	BSP010	TC062	T15	16 IR	
KE76	E25S - IR16	25	250	-	16,2	29	0,900	TC068	TA060	BSP010	TC062	T15	16 IR	
KE78	E20S - IR22	20	250	-	15,6	24,5	0,570	TC078 M4x11	-	-	-	T15	22 IR	

Carbide Threa Cutting Tool With Coolant

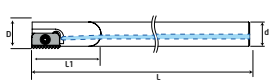

Order Code	Product Code	Dimensions (mm)									
		A	D	d	L	L1					
KE90	D9,9 d08 L125 A12 S12	12	9,9	8	125	-	0,049	TC060	T8	S12	
KE91	D13,2 d10 L110 A14 S14	14	13,2	10	110	-	0,067	TC093	T8	S14	
KE92	D13,2 d10 L155 A14 S14	14	13,2	10	155	-	0,100	TC093	T8	S14	
KE93	D15,2 d12 L175 A14 S14	14	15,2	12	175	-	0,167	TC093	T8	S14	
KE94	D21 d16 L130 A21 S21	21	21	16	130	-	0,212	TC074	T15	S21	
KE95	D21 d16 L200 A21 S21	21	21	16	200	-	0,327	TC074	T15	S21	

## Boring Bars Set



[www.teknikcuttingtools.com](http://www.teknikcuttingtools.com)



Kalite için TEKNIK çözüm  
Technical solution for quality

110-114





**SCLCR SET-IC**

Order Code	Product Code in Set	
iPS01 	A08H SCLCR 06	CCMT 0602
	A10J SCLCR 06	ISO.
	A12K SCLCR 06	
	A16M SCLCR 09	CCMT 0903

**SCLCL SET**

Order Code	Product Code in Set	
iPS04 	A08H SCLCL 06	CCMT 0602
	A10J SCLCL 06	ISO.
	A12K SCLCL 06	
	A16M SCLCL 09	CCMT 0903



**SCLCR SET-IC**

Order Code	Product Code in Set	
iPS07 	A06-08H SCLCR 06	
	A08-10J SCLCR 06	CCMT 0602
	A10-12K SCLCR 06	ISO.
	A12-16M SCLCR 06	



**SCLCL SET-IC**

Order Code	Product Code in Set	
iPS08 	A06-08H SCLCL 06	
	A08-10J SCLCL 06	CCMT 0602
	A10-12K SCLCL 06	ISO.
	A12-16M SCLCL 06	







**SDUCR SET**



Order Code	Product Code in Set	
iPS02 	A10J SDUCR 07	DCMT 0702
	A12K SDUCR 07	ISO.
	A16M SDUCR 07	

**SDUCL SET**



Order Code	Product Code in Set	
iPS05 	A10J SDUCL 07	DCMT 0702
	A12K SDUCL 07	ISO.
	A16M SDUCL 07	



**SDUCR SET -IC**



Order Code	Product Code in Set	
iPS09 	A08-10H SDUCR 07	DCMT 0702
	A10-12K SDUCR 07	ISO.
	A12-16M SDUCR 07	

**SDUCL SET -IC**



Order Code	Product Code in Set	
iPS10 	A08-10H SDUCL 07	DCMT 0702
	A10-12K SDUCL 07	ISO.
	A12-16M SDUCL 07	



**SDQCR SET**

Order Code	Product Code in Set	
iPS03 	A10J SDQCR 07	DCMT 0702
	A12K SDQCR 07	ISO.
	A16M SDQCR 07	

**SDQCL SET**

Order Code	Product Code in Set	
iPS06 	A10J SDQCL 07	DCMT 0702
	A12K SDQCL 07	ISO.
	A16M SDQCL 07	



**SCLCR SET**

Order Code	Product Code in Set	
İPS20	S08H SCLCR 06	CCMT 0602
	S10J SCLCR 06	ISO.
	S12K SCLCR 06	
	S16M SCLCR 09	CCMT 0903

**SCLCL SET**

Order Code	Product Code in Set	
İPS21	S08H SCLCL 06	CCMT 0602
	S10J SCLCL 06	ISO.
	S12K SCLCL 06	
	S16M SCLCL 09	CCMT 0903



**SDUCR SET**

Order Code	Product Code in Set	
İPS22	S10J SDUCR 07	DCMT 0702
	S12K SDUCR 07	ISO.
	S16M SDUCR 11	DCMT 11T3

**SDUCL SET**

Order Code	Product Code in Set	
İPS23	S10J SDUCL 07	DCMT 0702
	S12K SDUCL 07	ISO.
	S16M SDUCL 11	DCMT 11T3



**SDQCR SET**

Order Code	Product Code in Set	
İPS24	S10J SDQCR 07	DCMT 0702
	S12K SDQCR 07	ISO.
	S16M SDQCR 11	DCMT 11T3

**SDQCL SET**

Order Code	Product Code in Set	
İPS25	S10J SDQCL 07	DCMT 0702
	S12K SDQCL 07	ISO.
	S16M SDQCL 11	DCMT 11T3



# Technical Solution For Quality

Teknik Cutting Tools, we are a leading company that combines quality and innovation in the manufacturing of cutting tools. In our state-of-the-art production facility, we deliver industry-shaping solutions with a focus on precision and durability.



**KALİTE İÇİN TEKNİK ÇÖZÜM**  
**TECHNICAL SOLUTION FOR QUALITY**



## Indexable Drills



[www.teknikcuttingtools.com](http://www.teknikcuttingtools.com)



Kalite için TEKNİK çözüm  
Technical solution for quality

116-125



Adaptor Indexable Drill

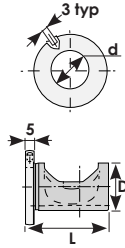

Order Code	Product Code	Dimensions (mm)		
		D	d	L
UA10	D25 d20 L46	25	20	46,5
UA12	D32 d25 L47	32	25	47
UA14	D40 d32 L57	40	32	57

D2 WCM\_

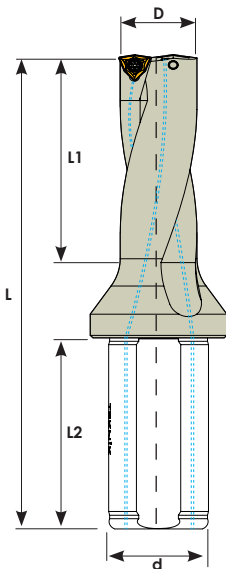
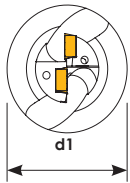

Order Code	Product Code	Dimensions (mm)									
		D	d	d1	L	L1	L2				
U104	16 D2 WCM_03	16	25	34	108	32	56	0,294	TC060	T8	WCM_0302
U105	17 D2 WCM_03	17	25	34	110	34	56	0,293	TC060	T8	KRLY
U106	18 D2 WCM_03	18	25	34	113	36	56	0,303	TC060	T8	
U107	19 D2 WCM_03	19	25	34	115	38	56	0,312	TC060	T8	
U108	20 D2 WCM_04	20	25	34	119	40	56	0,327	TC060	T8	
U110	21 D2 WCM_04	21	25	34	121	42	56	0,340	TC060	T8	WCM_0402
U112	22 D2 WCM_04	22	25	34	123	44	56	0,345	TC060	T8	KRLY
U114	23 D2 WCM_04	23	25	34	127	46	56	0,370	TC060	T8	
U116	24 D2 WCM_05	24	25	34	130	48	56	0,390	TC065	T8	
U118	25 D2 WCM_05	25	25	34	133	50	56	0,420	TC065	T8	
U120	26 D2 WCM_05	26	25	34	135	52	56	0,420	TC065	T8	WCM_0503
U122	27 D2 WCM_05	27	25	34	137	54	56	0,450	TC065	T8	KRLY
U124	28 D2 WCM_05	28	25	39	140	56	56	0,491	TC065	T8	
U126	29 D2 WCM_05	29	25	39	142	58	56	0,515	TC065	T8	
U128	30 D2 WCM_06	30	32	44	151	60	58	0,755	TC067	T10	
U130	31 D2 WCM_06	31	32	44	154	62	58	0,775	TC067	T10	
U132	32 D2 WCM_06	32	32	44	156	64	58	0,802	TC067	T10	
U134	33 D2 WCM_06	33	32	44	159	66	58	0,845	TC067	T10	WCM_06T3
U136	34 D2 WCM_06	34	32	44	161	68	58	0,851	TC067	T10	KRLY
U137	35 D2 WCM_06	35	32	44	164	70	58	0,900	TC067	T10	
U138	36 D2 WCM_06	36	32	44	167	72	58	0,970	TC067	T10	
U139	37 D2 WCM_06	37	32	44	170	74	58	0,875	TC067	T10	
U140	38 D2 WCM_06	38	32	44	173	76	58	0,975	TC067	T10	
U141	39 D2 WCM_06	39	32	44	175	78	58	1,006	TC067	T10	
U142	40 D2 WCM_06	40	32	44	178	80	58	1,007	TC067	T10	

Compatible with / Kompatible für (KRLY)

D3 WCM\_

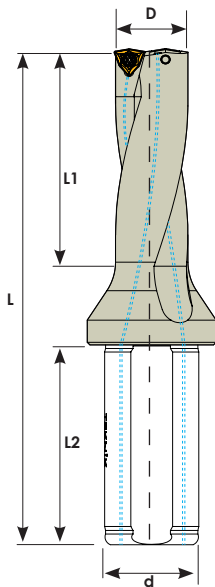
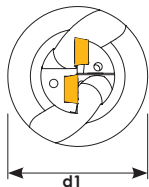

Order Code	Product Code	Dimensions (mm)							K <sub>20</sub>			
		D	d	d1	L	L1	L2					
U143	16 D3 WCM_03	16	25	34	124	48	56	0,307	TC060	T8		
U143-1	16,5 D3 WCM_03	16,5	25	34	124	48	56	0,304	TC060	T8		
U144	17 D3 WCM_03	17	25	34	127	51	56	0,320	TC060	T8	WCM_0302	
U145	17,5 D3 WCM_03	17,5	25	34	127	51	56	0,336	TC060	T8	KRLY	
U146	18 D3 WCM_03	18	25	34	131	54	56	0,332	TC060	T8		
U147	18,5 D3 WCM_03	18,5	25	34	131	54	56	0,348	TC060	T8		
U148	19 D3 WCM_03	19	25	34	134	57	56	0,338	TC060	T8		
U149	19,5 D3 WCM_03	19,5	25	34	134	57	56	0,340	TC060	T8		
U150	20 D3 WCM_04	20	25	34	139	60	56	0,344	TC060	T8		
U151	20,5 D3 WCM_04	20,5	25	34	139	60	56	0,360	TC060	T8		
U152	21 D3 WCM_04	21	25	34	142	63	56	0,376	TC060	T8	WCM_0402	
U153	21,5 D3 WCM_04	21,5	25	34	142	63	56	0,281	TC060	T8	KRLY	
U154	22 D3 WCM_04	22	25	34	145	66	56	0,385	TC060	T8		
U155	22,5 D3 WCM_04	22,5	25	34	145	66	56	0,394	TC060	T8		
U156	23 D3 WCM_04	23	25	34	150	69	56	0,400	TC060	T8		
U157	23,5 D3 WCM_04	23,5	25	34	150	69	56	0,413	TC06	T8		
U158	24 D3 WCM_05	24	25	34	154	72	56	0,446	TC065	T8		
U159	24,5 D3 WCM_05	24,5	25	34	154	72	56	0,453	TC065	T8		
U160	25 D3 WCM_05	25	25	34	158	75	56	0,467	TC065	T8	WCM_0503	
U161	25,5 D3 WCM_05	25,5	25	34	158	75	56	0,490	TC065	T8	KRLY	
U162	26 D3 WCM_05	26	25	34	161	78	56	0,494	TC065	T8		
U163	26,5 D3 WCM_05	26,5	25	34	161	78	56	0,497	TC065	T8		
U164	27 D3 WCM_05	27	25	34	164	81	56	0,512	TC065	T8		
U165	27,5 D3 WCM_05	27,5	25	34	164	81	56	0,520	TC065	T8		
U166	28 D3 WCM_05	28	25	39	168	84	56	0,576	TC065	T8		
U167	28,5 D3 WCM_05	28,5	25	39	168	84	56	0,584	TC065	T8		
U168	29 D3 WCM_05	29	25	39	171	87	56	0,617	TC065	T8		
U169	29,5 D3 WCM_05	29,5	25	39	171	87	56	0,610	TC065	T8		

Compatible with / Kompatible für (KRLY)

D3 WCM\_

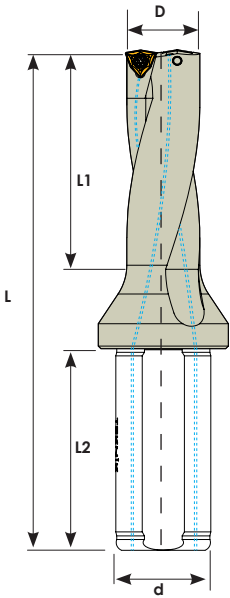
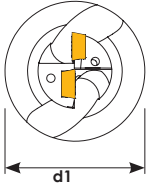

Order Code	Product Code	Dimensions (mm)										
		D	d	d1	L	L1	L2					
U170	30 D3 WCM_06	30	32	44	181	90	58	0,847	TC067	T15		
U171	30,5 D3 WCM_06	30,5	32	44	181	90	58	0,844	TC067	T15		
U172	31 D3 WCM_06	31	32	44	185	93	58	0,872	TC067	T15	WCM_06T3	
U174	32 D3 WCM_06	32	32	44	188	96	58	0,921	TC067	T15	KRLY	
U176	33 D3 WCM_06	33	32	44	192	99	58	0,973	TC067	T15		
U178	34 D3 WCM_06	34	32	44	195	102	58	1,037	TC067	T15		
U179	35 D3 WCM_06	35	32	44	199	105	58	1,082	TC067	T15		
U180	36 D3 WCM_06	36	32	44	203	108	58	1,092	TC067	T15		
U181	37 D3 WCM_06	37	32	44	207	111	58	1,141	TC067	T15		
U182	38 D3 WCM_06	38	32	44	211	114	58	1,188	TC067	T15		
U183	39 D3 WCM_06	39	32	44	214	117	58	1,244	TC067	T15		
U184	40 D3 WCM_06	40	32	44	218	120	58	1,295	TC067	T15		
U186	41 D3 WCM_06	41	32	49	232	123	58	1,465	TC067	T15		
U188	42 D3 WCM_06	42	32	49	235	126	58	1,646	TC067	T15		
U190	43 D3 WCM_06	43	32	54	239	129	58	1,726	TC067	T15		
U192	44 D3 WCM_06	44	32	54	242	132	58	1,916	TC067	T15		
U194	45 D3 WCM_06	45	40	59	247	135	68	2,238	TC067	T15		
U196	46 D3 WCM_08	46	40	59	251	138	68	2,276	TC074	T15		
U198	47 D3 WCM_08	47	40	59	254	141	68	1,919	TC074	T15		
U200	48 D3 WCM_08	48	40	59	258	144	68	2,486	TC074	T15		
U201	49 D3 WCM_08	49	40	59	261	147	68	5,562	TC074	T15		
U202	50 D3 WCM_08	50	40	59	265	150	68	2,725	TC074	T15	WCM_0804	
U203	51 D3 WCM_08	51	40	59	268	153	68	2,537	TC074	T15	KRLY	
U205	52 D3 WCM_08	52	40	59	271	156	68	2,655	TC074	T15		
U207	53 D3 WCM_08	53	40	59	274	159	68	2,740	TC074	T15		
U209	54 D3 WCM_08	54	40	59	277	162	68	3,210	TC074	T15		
U211	55 D3 WCM_08	55	40	59	280	165	68	3,237	TC074	T15		

Compatible with / Kompatible für (KRLY)

D4 WCM\_

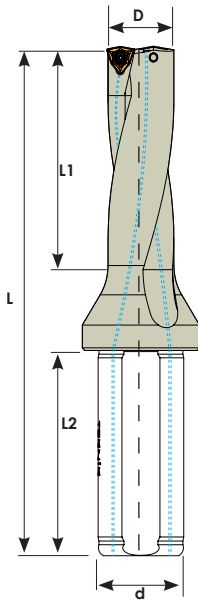
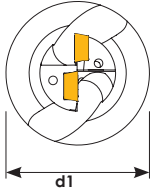
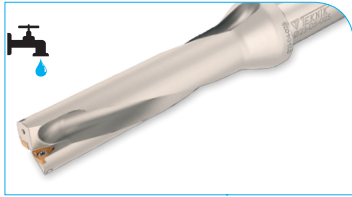

Order Code	Product Code	Dimensions (mm)							TC	T	KRLY
		D	d	d1	L	L1	L2	TC			
U600	16 D4 WCM_03	16	25	34	140	64	56	0,324	TC060	T8	
U602	17 D4 WCM_03	17	25	34	144	68	56	0,328	TC060	T8	WCM_0302
U604	18 D4 WCM_03	18	25	34	149	72	56	0,355	TC060	T8	KRLY
U606	19 D4 WCM_03	19	25	34	153	76	56	0,357	TC060	T8	
U608	20 D4 WCM_04	20	25	34	159	80	56	0,383	TC060	T8	WCM_0402
U610	21 D4 WCM_04	21	25	34	163	84	56	0,411	TC060	T8	KRLY
U612	22 D4 WCM_04	22	25	34	167	88	56	0,430	TC060	T8	
U614	23 D4 WCM_04	23	25	34	173	92	56	0,464	TC060	T8	
U616	24 D4 WCM_05	24	25	34	178	96	56	0,425	TC065	T8	
U618	25 D4 WCM_05	25	25	34	183	100	56	0,526	TC065	T8	
U620	26 D4 WCM_05	26	25	34	187	104	56	0,542	TC065	T8	WCM_0503
U622	27 D4 WCM_05	27	25	34	191	108	56	0,580	TC065	T8	KRLY
U624	28 D4 WCM_05	28	25	39	196	112	56	0,662	TC065	T8	
U626	29 D4 WCM_05	29	25	39	200	116	56	0,680	TC065	T8	
U628	30 D4 WCM_06	30	32	44	211	120	58	0,912	TC067	T15	
U631	31 D4 WCM_06	31	32	44	216	124	58	0,981	TC067	T15	
U632	32 D4 WCM_06	32	32	44	220	128	58	1,046	TC067	T15	
U633	33 D4 WCM_06	33	32	44	225	132	58	1,102	TC067	T15	
U634	34 D4 WCM_06	34	32	44	229	136	58	1,111	TC067	T15	WCM_06T3
U635	35 D4 WCM_06	35	32	44	234	140	58	1,187	TC067	T15	KRLY
U636	36 D4 WCM_06	36	32	44	239	144	58	1,172	TC067	T15	
U637	37 D4 WCM_06	37	32	44	244	148	58	1,260	TC067	T15	
U638	38 D4 WCM_06	38	32	44	249	152	58	1,430	TC067	T15	
U639	39 D4 WCM_06	39	32	44	253	156	58	1,380	TC067	T15	
U640	40 D4 WCM_06	40	32	44	258	160	58	1,460	TC067	T15	

Compatible with / Kompatible für (KRLY)



D5 WCM\_

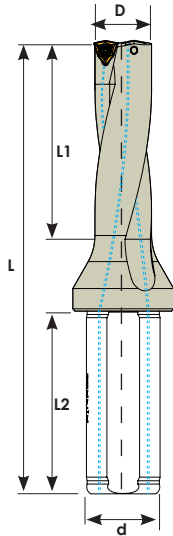
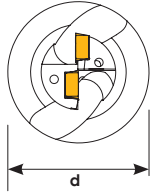

Order Code	Product Code	Dimensions (mm)							TC	T	KRLY
		D	d	d1	L	L1	L2	ISO			
U776	16 D5 WCM_03	16	25	34	156	80	56	0,378	TC060	T8	
U777	17 D5 WCM_03	17	25	34	161	85	56	0,468	TC060	T8	WCM_0302
U778	18 D5 WCM_03	18	25	34	167	90	56	0,471	TC060	T8	KRLY
U779	19 D5 WCM_03	19	25	34	172	95	56	0,397	TC060	T8	
U780	20 D5 WCM_04	20	25	34	179	100	56	0,421	TC060	T8	
U781	21 D5 WCM_04	21	25	34	184	105	56	0,451	TC060	T8	WCM_0402
U782	22 D5 WCM_04	22	25	34	190	110	56	0,470	TC060	T8	KRLY
U783	23 D5 WCM_04	23	25	34	196	115	56	0,504	TC060	T8	
U784	24 D5 WCM_05	24	25	34	202	120	56	0,465	TC065	T8	
U785	25 D5 WCM_05	25	25	34	208	125	56	0,678	TC065	T8	WCM_0503
U786	26 D5 WCM_05	26	25	34	213	130	56	0,620	TC065	T8	KRLY
U787	27 D5 WCM_05	27	25	34	218	135	56	0,620	TC065	T8	
U788	28 D5 WCM_05	28	25	39	224	140	56	0,742	TC065	T8	
U789	29 D5 WCM_05	29	25	39	229	145	56	0,760	TC065	T8	
U790	30 D5 WCM_06	30	32	44	241	150	58	0,992	TC067	T15	
U791	31 D5 WCM_06	31	32	44	246	155	58	1,061	TC067	T15	
U792	32 D5 WCM_06	32	32	44	252	160	58	1,126	TC067	T15	WCM_06T3
U793	33 D5 WCM_06	33	32	44	258	165	58	1,182	TC067	T15	KRLY
U794	34 D5 WCM_06	34	32	44	263	170	58	1,191	TC067	T15	
U795	35 D5 WCM_06	35	32	44	269	175	58	1,227	TC067	T15	
U796	36 D5 WCM_06	36	32	44	275	180	58	1,172	TC067	T15	
U797	37 D5 WCM_06	37	32	44	281	185	58	1,300	TC067	T15	
U798	38 D5 WCM_06	38	32	44	287	190	58	1,480	TC067	T15	
U799	39 D5 WCM_06	39	32	44	292	195	58	1,520	TC067	T15	
U800	40 D5 WCM_06	40	32	44	298	200	58	1,490	TC067	T15	

Compatible with / Kompatible für (KRLY)



**D2 SPMG**

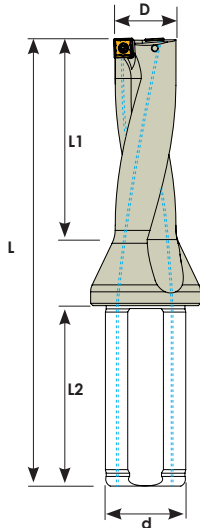
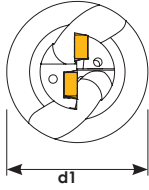



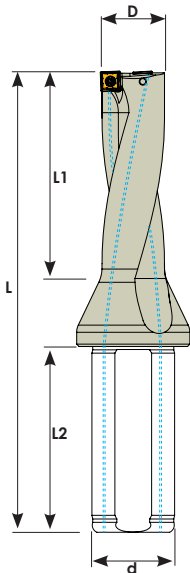
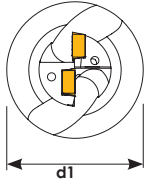
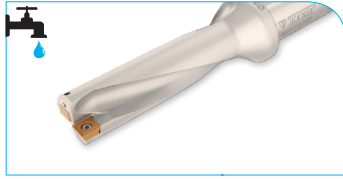

Order Code	Product Code	Dimensions (mm)							TC	T	Material
		D	d	d1	L	L1	L2	kg			
U913	13 D2 SPMG 05	13	20	25	94	26	50	0,145	TC058	T6	SPMG 0502
U914	14 D2 SPMG 05	14	20	25	96	28	50	0,152	TC058	T6	TGTC YG-1
U915	15 D2 SPMG 05	15	20	25	99	30	50	0,157	TC058	T6	
U916	16 D2 SPMG 06	16	25	34	108	32	56	0,275	TC059	T7	
U917	17 D2 SPMG 06	17	25	34	110	34	56	0,291	TC059	T7	
U918	18 D2 SPMG 06	18	25	34	113	36	56	0,302	TC059	T7	SPMG 0602
U919	19 D2 SPMG 06	19	25	34	115	38	56	0,329	TC059	T7	TGTC YG-1
U920	20 D2 SPMG 06	20	25	34	119	40	56	0,334	TC059	T7	
U921	21 D2 SPMG 06	21	25	34	121	42	56	0,338	TC059	T7	
U922	22 D2 SPMG 07	22	25	34	123	44	56	0,340	TC063	T8	
U923	23 D2 SPMG 07	23	25	34	127	46	56	0,354	TC063	T8	SPMG 07T3
U924	24 D2 SPMG 07	24	25	34	130	48	56	0,382	TC063	T8	TGTC YG-1
U925	25 D2 SPMG 07	25	25	34	133	50	56	0,450	TC063	T8	
U926	26 D2 SPMG 07	26	25	34	135	52	56	0,423	TC063	T8	
U927	27 D2 SPMG 07	27	25	34	137	54	56	0,435	TC063	T8	
U928	28 D2 SPMG 09	28	25	39	140	56	56	0,500	TC067	T15	
U929	29 D2 SPMG 09	29	25	39	142	58	56	0,535	TC067	T15	SPMG 0904
U930	30 D2 SPMG 09	30	32	44	151	60	58	0,735	TC067	T15	TGTC YG-1
U931	31 D2 SPMG 09	31	32	44	154	62	58	0,766	TC067	T15	
U932	32 D2 SPMG 09	32	32	44	156	64	58	0,781	TC067	T15	
U933	33 D2 SPMG 09	33	32	44	159	66	58	0,815	TC067	T15	
U934	34 D2 SPMG 11	34	32	44	161	68	58	0,784	TC074	T15	
U935	35 D2 SPMG 11	35	32	44	164	70	58	0,845	TC074	T15	SPMG 1104
U936	36 D2 SPMG 11	36	32	44	167	72	58	0,893	TC074	T15	TGTC YG-1
U937	37 D2 SPMG 11	37	32	44	170	74	58	0,931	TC074	T15	
U938	38 D2 SPMG 11	38	32	44	173	76	58	0,992	TC074	T15	
U939	39 D2 SPMG 11	39	32	44	175	78	58	1,007	TC074	T15	
U940	40 D2 SPMG 11	40	32	44	178	80	58	1,020	TC074	T15	

*Compatible with/ Kompatible (TGTC-YG-1)*

D3 SPMG



Order Code	Product Code	Dimensions (mm)									
		D	d	d1	L	L1	L2				
U812	12,5 D3 SPMG 05	12,5	20	12	106	38	50	0,158	TC058	T6	
U813	13 D3 SPMG 05	13	20	25	107	39	50	0,164	TC058	T6	SPMG 0502
U813-1	13,5 D3 SPMG 05	13,5	20	25	107	39	50	0,167	TC058	T6	TGTC
U814	14 D3 SPMG 05	14	20	25	110	42	50	0,170	TC058	T6	YG-1
U814-1	14,5 D3 SPMG 05	14,5	20	25	110	42	50	0,170	TC058	T6	
U815	15 D3 SPMG 05	15	20	25	114	45	50	0,175	TC058	T6	
U815-1	15,5 D3 SPMG 05	15,5	20	25	114	45	50	0,175	TC058	T6	
U816	16 D3 SPMG 06	16	25	34	124	48	56	0,302	TC059	T7	
U816-1	16,5 D3 SPMG 06	16,5	25	34	124	48	56	0,302	TC059	T7	
U817	17 D3 SPMG 06	17	25	34	127	51	56	0,318	TC059	T7	
U817-1	17,5 D3 SPMG 06	17,5	25	34	127	51	56	0,318	TC059	T7	
U818	18 D3 SPMG 06	18	25	34	131	54	56	0,327	TC059	T7	SPMG 0602
U818-1	18,5 D3 SPMG 06	18,5	25	34	131	54	56	0,327	TC059	T7	TGTC
U819	19 D3 SPMG 06	19	25	34	134	57	56	0,330	TC059	T7	YG-1
U819-1	19,5 D3 SPMG 06	19,5	25	34	134	57	56	0,330	TC059	T7	
U820	20 D3 SPMG 06	20	25	34	139	60	56	0,347	TC059	T7	
U820-1	20,5 D3 SPMG 06	20,5	25	34	139	60	56	0,350	TC059	T7	
U821	21 D3 SPMG 06	21	25	34	142	63	56	0,377	TC059	T7	
U821-1	21,5 D3 SPMG 06	21,5	25	34	142	63	56	0,377	TC059	T7	
U822	22 D3 SPMG 07	22	25	34	145	66	56	0,375	TC063	T8	
U822-1	22,5 D3 SPMG 07	22,5	25	34	145	66	56	0,375	TC063	T8	
U823	23 D3 SPMG 07	23	25	34	150	69	56	0,407	TC063	T8	
U823-1	23,5 D3 SPMG 07	23,5	25	34	150	69	56	0,412	TC063	T8	
U824	24 D3 SPMG 07	24	25	34	154	72	56	0,446	TC063	T8	SPMG 07T3
U824-1	24,5 D3 SPMG 07	24,5	25	34	154	72	56	0,452	TC063	T8	TGTC
U825	25 D3 SPMG 07	25	25	34	158	75	56	0,460	TC063	T8	YG-1
U825-1	25,5 D3 SPMG 07	25,5	25	34	158	75	56	0,467	TC063	T8	
U826	26 D3 SPMG 07	26	25	34	161	78	56	0,481	TC063	T8	
U826-1	26,5 D3 SPMG 07	26,5	25	34	161	78	56	0,487	TC063	T8	
U827	27 D3 SPMG 07	27	25	34	164	81	56	0,504	TC063	T8	
U827-1	27,5 D3 SPMG 07	27,5	25	34	164	81	56	0,511	TC063	T8	
U828	28 D3 SPMG 09	28	25	39	168	84	56	0,562	TC067	T15	
U828-1	28,5 D3 SPMG 09	28,5	25	39	168	84	56	0,572	TC067	T15	
U829	29 D3 SPMG 09	29	25	39	171	87	56	0,580	TC067	T15	SPMG 0904
U829-1	29,5 D3 SPMG 09	29,5	25	39	171	87	56	0,585	TC067	T15	TGTC
U830	30 D3 SPMG 09	30	32	44	181	90	58	0,823	TC067	T15	YG-1
U831	31 D3 SPMG 09	31	32	44	185	93	58	0,884	TC067	T15	
U832	32 D3 SPMG 09	32	32	44	188	96	58	0,923	TC067	T15	
U833	33 D3 SPMG 09	33	32	44	192	99	58	0,920	TC067	T15	
U834	34 D3 SPMG 11	34	32	44	195	102	58	0,943	TC074	T15	
U835	35 D3 SPMG 11	35	32	44	199	105	58	0,960	TC074	T15	SPMG 1104
U836	36 D3 SPMG 11	36	32	44	203	108	58	1,043	TC074	T15	TGTC
U837	37 D3 SPMG 11	37	32	44	207	111	58	1,057	TC074	T15	YG-1
U838	38 D3 SPMG 11	38	32	44	211	114	58	1,062	TC074	T15	
U839	39 D3 SPMG 11	39	32	44	214	117	58	1,155	TC074	T15	
U840	40 D3 SPMG 11	40	32	44	218	120	58	1,238	TC074	T15	

Compatible with/ Kompatible (TGTC-YG-1)

**D4 SPMG**

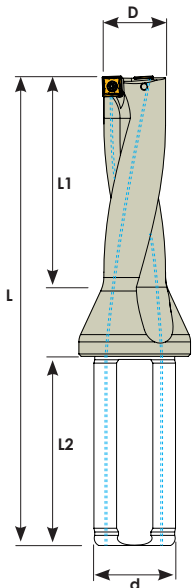
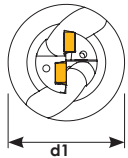

Order Code	Product Code	Dimensions (mm)									
		D	d	d1	L	L1	L2				
U713	13 D4 SPMG 05	13	20	25	120	52	50	0,170	TC058	T6	SPMG 0502
U714	14 D4 SPMG 05	14	20	25	124	56	50	0,180	TC058	T6	TGTC
U715	15 D4 SPMG 05	15	20	25	129	60	50	0,190	TC058	T6	YG-1
U716	16 D4 SPMG 06	16	25	34	140	64	56	0,330	TC059	T7	
U717	17 D4 SPMG 06	17	25	34	144	68	56	0,333	TC059	T7	
U718	18 D4 SPMG 06	18	25	34	149	72	56	0,350	TC059	T7	SPMG 0602
U719	19 D4 SPMG 06	19	25	34	153	76	56	0,357	TC059	T7	TGTC
U720	20 D4 SPMG 06	20	25	34	159	80	56	0,383	TC059	T7	YG-1
U721	21 D4 SPMG 06	21	25	34	163	84	56	0,387	TC059	T7	
U722	22 D4 SPMG 07	22	25	34	167	88	56	0,417	TC063	T8	
U723	23 D4 SPMG 07	23	25	34	173	92	56	0,448	TC063	T8	SPMG 07T3
U724	24 D4 SPMG 07	24	25	34	178	96	56	0,460	TC063	T8	TGTC
U725	25 D4 SPMG 07	25	25	34	183	100	56	0,505	TC063	T8	YG-1
U726	26 D4 SPMG 07	26	25	34	187	104	56	0,539	TC063	T8	
U727	27 D4 SPMG 07	27	25	34	191	108	56	0,561	TC063	T8	
U728	28 D4 SPMG 09	28	25	39	196	112	56	0,642	TC067	T15	
U729	29 D4 SPMG 09	29	25	39	200	116	56	0,646	TC067	T15	SPMG 0904
U730	30 D4 SPMG 09	30	32	44	211	120	58	0,930	TC067	T15	TGTC
U731	31 D4 SPMG 09	31	32	44	216	124	58	0,974	TC067	T15	YG-1
U732	32 D4 SPMG 09	32	32	44	220	128	58	1,014	TC067	T15	
U733	33 D4 SPMG 09	33	32	44	225	132	58	1,050	TC067	T15	
U734	34 D4 SPMG 11	34	32	44	229	136	58	1,040	TC074	T15	
U735	35 D4 SPMG 11	35	32	44	234	140	58	1,155	TC074	T15	SPMG 1104
U736	36 D4 SPMG 11	36	32	44	239	144	58	1,185	TC074	T15	TGTC
U737	37 D4 SPMG 11	37	32	44	244	148	58	1,232	TC074	T15	YG-1
U738	38 D4 SPMG 11	38	32	44	249	152	58	1,320	TC074	T15	
U739	39 D4 SPMG 11	39	32	44	253	156	58	1,356	TC074	T15	
U740	40 D4 SPMG 11	40	32	44	258	160	58	1,421	TC074	T15	

*Compatible with / Kompatible für (TGTC-YG-1)*

**D3 SPMT**

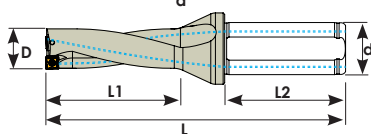

Order Code	Product Code	Dimensions (mm)									
		D	d	d1	L	L1	L2				
U004	13 D3 SPMT 05	13	20	25	107	39	50	0,154	TC058	T6	SPMT 0502
U006	14 D3 SPMT 05	14	20	25	110	42	50	0,158	TC058	T6	KRLY.
U008	15 D3 SPMT 05	15	20	25	114	45	50	0,168	TC058	T6	
U010	16 D3 SPMT 06	16	25	34	124	48	56	0,308	TC059	T7	
U012	17 D3 SPMT 06	17	25	34	127	51	56	0,313	TC059	T7	SPMT 0602
U014	18 D3 SPMT 06	18	25	34	131	54	56	0,327	TC059	T7	KRLY
U016	19 D3 SPMT 06	19	25	34	134	57	56	0,350	TC059	T7	
U018	20 D3 SPMT 07	20	25	34	139	60	56	0,353	TC063	T8	SPMT 0702
U020	21 D3 SPMT 07	21	25	34	142	63	56	0,395	TC063	T8	KRLY.

*Compatible with / Kompatible für (KRLY)*

**D3 SOMT**

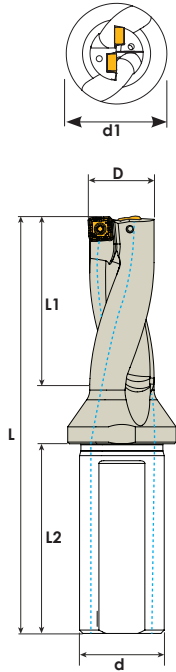

Order Code	Product Code	Dimensions (mm)							TC	TC	TC	TC
		D	d	d1	L	L1	L2	TC				
U302	14 D3 SOMT 05	14	20	25	114	42	50	0,165	TC058	T6	SOMT 0502	
U303	14,5 D3 SOMT 05	14,5	20	25	114	42	50	0,170	TC058	T6	TGTC	
U304	15 D3 SOMT 05	15	20	25	117	45	50	0,175	TC058	T6		
U305	15,5 D3 SOMT 05	15,5	20	25	117	45	50	0,175	TC058	T6		
U306	16 D3 SOMT 05	16	25	34	126	48	56	0,302	TC058	T6		
U307	16,5 D3 SOMT 06	16,5	25	34	126	48	56	0,302	TC059	T7	SOMT 0602	
U308	17 D3 SOMT 06	17	25	34	129	51	56	0,318	TC059	T7	TGTC	
U309	17,5 D3 SOMT 06	17,5	25	34	129	51	56	0,318	TC059	T7		
U310	18 D3 SOMT 06	18	25	34	132	54	56	0,327	TC059	T7		
U311	18,5 D3 SOMT 06	18,5	25	34	132	54	56	0,327	TC059	T7		
U312	19 D3 SOMT 06	19	25	34	135	57	56	0,330	TC059	T7		
U313	19,5 D3 SOMT 07	19,5	25	34	135	57	56	0,330	TC059	T7	SOMT 07T3	
U314	20 D3 SOMT 07	20	25	34	138	60	56	0,347	TC059	T7	TGTC	
U315	20,5 D3 SOMT 07	20,5	25	34	138	60	56	0,350	TC059	T7		
U316	21 D3 SOMT 07	21	25	34	141	63	56	0,377	TC059	T7		
U318	22 D3 SOMT 08	22	25	34	144	66	56	0,375	TC063	T8		
U319	22,5 D3 SOMT 08	22,5	25	34	144	66	56	0,375	TC063	T8	SOMT 08T3	
U320	23 D3 SOMT 08	23	25	34	147	69	56	0,407	TC063	T8	TGTC	
U321	23,5 D3 SOMT 08	23,5	25	34	147	69	56	0,412	TC063	T8		
U322	24 D3 SOMT 08	24	25	34	150	72	56	0,446	TC063	T8		
U323	24,5 D3 SOMT 08	24,5	25	34	150	72	56	0,452	TC063	T8		
U324	25 D3 SOMT 08	25	25	34	153	75	56	0,460	TC063	T8		

Compatible with. / Kompatible für (TGTC)

**D4 SOMT**

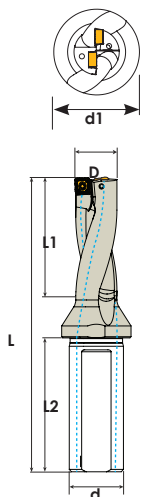

Order Code	Product Code	Dimensions (mm)							TC	TC	TC	TC
		D	d	d1	L	L1	L2	TC				
U402	14 D4 SOMT 05	14	20	25	128	56	50	0,170	TC058	T6	SOMT 0502	
U403	14,5 D4 SOMT 05	14,5	20	25	128	56	50	0,175	TC058	T6	TGTC	
U406	16 D4 SOMT 05	16	25	34	142	64	56	0,322	TC058	T6		
U408	17 D4 SOMT 06	17	25	34	146	68	56	0,338	TC059	T7	SOMT 0602	
U409	17,5 D4 SOMT 06	17,5	25	34	146	68	56	0,348	TC059	T7	TGTC	
U410	18 D4 SOMT 06	18	25	34	150	72	56	0,347	TC059	T7		
U412	19 D4 SOMT 06	19	25	34	154	76	56	0,350	TC059	T7		
U414	20 D4 SOMT 07	20	25	34	158	8	56	0,387	TC059	T7	SOMT 07T3	
U416	21 D4 SOMT 07	21	25	34	162	84	56	0,417	TC059	T7	TGTC	
U418	22 D4 SOMT 07	22	25	34	166	88	56	0,425	TC059	T7		
U420	24 D4 SOMT 08	24	25	34	174	96	56	0,486	TC063	T8	SOMT 08T3	
U422	25 D4 SOMT 08	25	25	34	178	100	56	0,498	TC063	T8	TGTC	

Compatible with. / Kompatible für (TGTC)

D2-D3 XCMT-QCMT

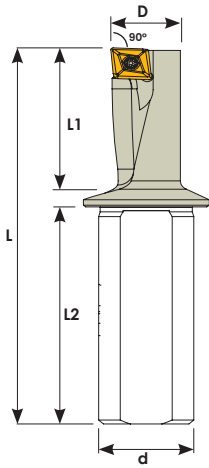
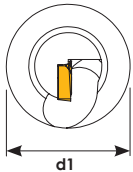
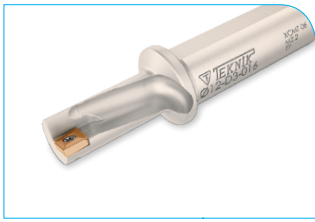

Order Code	Product Code	Dimensions (mm)							TC	T	Material
		D	d	d1	L	L1	L2	kg			
U030	10 D2,25 QC-- 050204	10	12	16	74,5	22,5	42	0,062	TC058	T6	QC-- 050204 KRLY
U032	12 D2,25 QC-- 060204	12	16	20	85	27	45	0,100	TC059	T7	QC-- 060204 KRLY
U034	14 D2,25 QC-- 070304	14	16	20	90	31,5	45	0,111	TC060	T8	QC-- 070304 KRLY
U036	16 D2,25 QC-- 080304	16	20	25	100	36	50	0,191	TC065	T8	QC-- 080304 KRLY
U040	20 D2,25 QC-- 10T304	20	25	31	116	45	56	0,330	TC067	T15	QC-- 10T304 KRLY
U042	25 D2,25 QC-- 130404	25	32	39	135	56,5	60	0,600	TC080	T15	QC-- 130404 KRLY
U038	18 D2,25 XC-- 09T304	18	25	31	112	40,5	56	0,356	TC065	T8	XCMT 09T304 ISCR

Compatible with / Kompatibel für (KRLY)(QC--)(QX--)  
Compatible with / Kompatibel für (ISCR)(QC--)(QX--)

Order Code	Product Code	Dimensions (mm)							TC	T	Material
		D	d	d1	L	L1	L2	kg			
U08	8 D2 XC-- 040104	8	12	16	68	18	42	0,056	TC058	T6	XCMT 0401 TGTC
U12	10 D3 XC-- 050204	10	16	25	90	30	45	0,109	TC058	T6	XCMT 0502
U14	10,5 D3 XC-- 050204	10,5	16	25	90	31	45	0,111	TC058	T6	TGTC
U18	11,5 D3 XC-- 060204	11,5	16	25	92	35	45	0,113	TC059	T7	XCMT 0602
U20	12 D3 XC-- 060204	12	16	25	94	36	45	0,114	TC059	T7	TGTC

Compatible with. / Kompatibel für (TGTC)

Alüminyum											
Order Code	Product Code	Dimensions (mm)							TC	T	Material
		D	d	d1	L	L1	L2	kg			
U32	10,5 D3 XC-- 050204	10,5	16	25	90	31	45	0,114	TC058	T6	XCMT 050204
U34	11 D3 XC-- 050204	11	16	25	92	33	45	0,112	TC058	T6	TGTC
U36	11,5 D3 XC-- 060204	11,5	16	25	92	35	45	0,112	TC059	T7	XCMT 060204 TGTC

Compatible with. / Kompatibel für (TGTC)

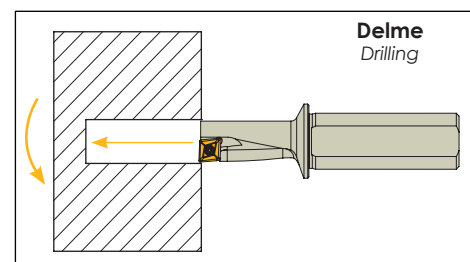
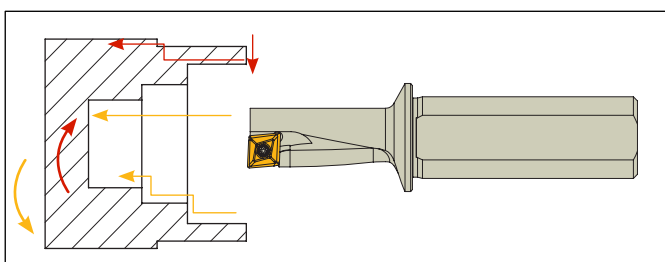

Kalite için **TEKNIK** çözüm  
Technical solution for quality



THE **TEKNIK MAKİNA**®  
**EXCEPTIONAL CUTTING TOOLS**  
COLLECTION

[www.teknikmakinatakim.com](http://www.teknikmakinatakim.com)

## Grooving Holders

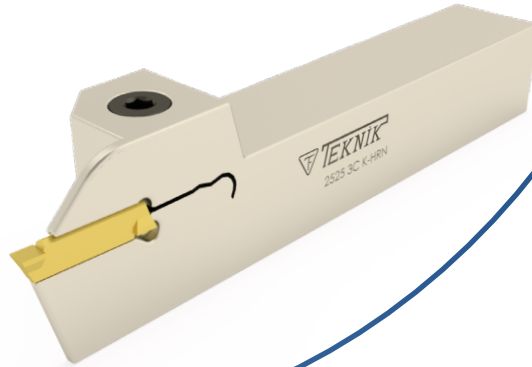
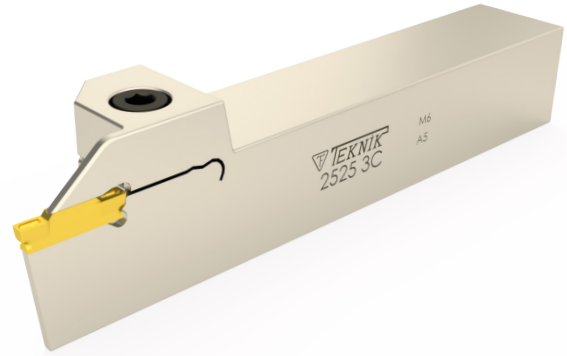
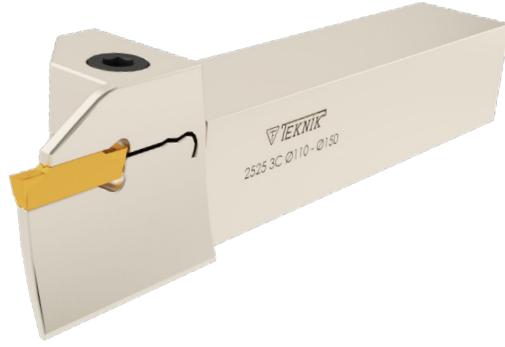

[www.teknikcuttingtools.com](http://www.teknikcuttingtools.com)



Kalite için TEKNİK çözüm  
Technical solution for quality

128-136



**KRLY-R**

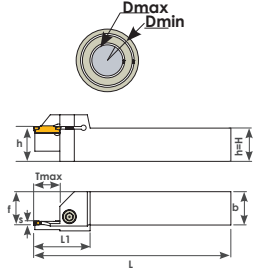
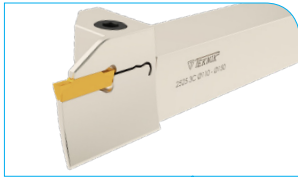

Order Code	Product Code	Dimensions (mm)												
		Dmin	Dmax	S	Tmax	f	b	h	L	L1				
D780	2525 3C-R (50-60)	50	60	3	17	25	25	25	150	40	0,741	TC134	5 Allen	
D782	2525 3C-R (60-80)	60	80	3	17	25	25	25	150	40	0,717	TC134	5 Allen	MGM 300
D784	2525 3C-R (80-110)	80	110	3	17	25	25	25	150	40	0,720	TC134	5 Allen	KRLY.
D785	2525 3C-R (110-150)	110	150	3	17	25	25	25	150	40	0,730	TC134	5 Allen	
D786	2525 4C-R (50-60)	50	60	4	20	25	25	25	150	45	0,704	TC134	5 Allen	
D788	2525 4C-R (60-80)	60	80	4	20	25	25	25	150	45	0,712	TC134	5 Allen	MGM 400
D790	2525 4C-R (80-110)	80	110	4	20	25	25	25	150	45	0,701	TC134	5 Allen	KRLY.
D791	2525 4C-R (110-150)	110	150	4	20	25	25	25	150	45	0,712	TC134	5 Allen	
D791-1	2525 4C (140-600)	140	600	4	25	25	25	25	150	49	0,667	TC134	5 Allen	
D792	2525 5C-R (50-80)	50	80	5	20	25	25	25	150	45	0,721	TC134	5 Allen	
D796	2525 5C-R (80-110)	80	110	5	20	25	25	25	150	45	0,716	TC134	5 Allen	MGM 500
D798	2525 5C-R (110-150)	110	150	5	20	25	25	25	150	45	0,718	TC134	5 Allen	KRLY.
D799-1	2525 5C-R (350-500)	350	500	5	20	25	25	25	150	45	0,713	TC134	5 Allen	
D799-2	2525 5C-R (140-600)	140	600	5	25	25	25	25	150	49	0,664	TC134	5 Allen	

Compatible with / Kompatibel für (KRLY)

**KRLY-L**

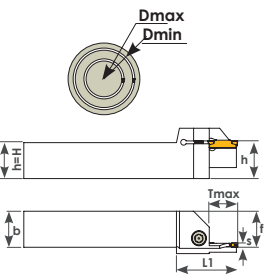

Order Code	Product Code	Dimensions (mm)												
		Dmin	Dmax	S	Tmax	f	b	h	L	L1				
D800	2525 3C-L (50-60)	50	60	3	17	25	25	25	150	40	0,741	TC134	5 Allen	
D802	2525 3C-L (60-80)	60	80	3	17	25	25	25	150	40	0,717	TC134	5 Allen	MGM 300
D804	2525 3C-L (80-110)	80	110	3	17	25	25	25	150	40	0,720	TC134	5 Allen	KRLY
D805	2525 3C-L (110-150)	110	150	3	17	25	25	25	150	40	0,730	TC134	5 Allen	
D806	2525 4C-L (50-60)	50	60	4	20	25	25	25	150	45	0,704	TC134	5 Allen	
D808	2525 4C-L (60-80)	60	80	4	20	25	25	25	150	45	0,712	TC134	5 Allen	MGM 400
D810	2525 4C-L (80-110)	80	110	4	20	25	25	25	150	45	0,700	TC134	5 Allen	KRLY
D811	2525 4C-L (110-150)	110	150	4	20	25	25	25	150	45	0,712	TC134	5 Allen	
D811-1	2525 4C-L (140-600)	140	600	4	25	25	25	25	150	49	0,667	TC134	5 Allen	
D812	2525 5C-L (50-80)	50	80	5	20	25	25	25	150	45	0,721	TC134	5 Allen	
D816	2525 5C-L (80-110)	80	110	5	20	25	25	25	150	45	0,716	TC134	5 Allen	
D818	2525 5C-L (110-150)	110	150	5	20	25	25	25	150	45	0,718	TC134	5 Allen	MGM 500
D819	2525 5C-L (140-600)	140	600	5	25	25	25	25	150	49	0,664	TC134	5 Allen	KRLY
D819-1	2525 5C-L (350-500)	350	500	5	20	25	25	25	150	45	0,713	TC134	5 Allen	

Compatible with / Kompatibel für (KRLY)

**MGMN**

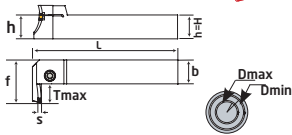
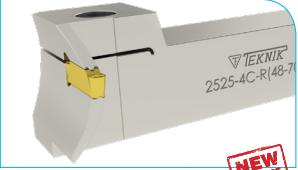

Order Code	Product Code	Dimensions (mm)												
		Dmin	Dmax	S	Tmax	f	b	h	L					
D820	2525 MGMN 3C-R (24-36)	24	36	3	17	42,5	25	25	150	0,773	TC134	5 Allen		
D821	2525 MGMN 3C-R (36-48)	36	48	3	17	42,5	25	25	150	0,772	TC134	5 Allen	MGM 300	
D822	2525 MGMN 3C-R (48-70)	48	70	3	17	42,5	25	25	150	0,767	TC134	5 Allen	KRLY.	
D823	2525 MGMN 3C-R (70-110)	70	110	3	17	42,5	25	25	150	0,762	TC134	5 Allen		
D829	2525 MGMN 4C-4 (36-48)	36	48	4	20	42,5	25	25	150	0,775	TC134	5 Allen		
D830	2525 MGMN 4C-R (48-70)	48	70	4	20	42,5	25	25	150	0,783	TC134	5 Allen	MGM 400	
D831	2525 MGMN 4C-R (70-110)	70	110	4	20	45	25	25	150	0,768	TC134	5 Allen	KRLY.	
D832	2525 MGMN 4C-R (110-150)	110	150	4	20	45	25	25	150	0,776	TC134	5 Allen		

Compatible with / Kompatibel für (KRLY)

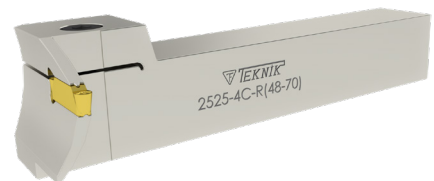

MGM/R

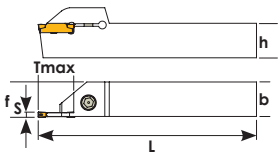
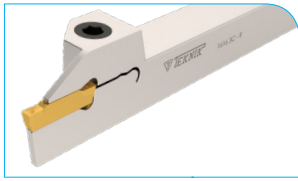

Order Code	Product Code	Dimensions (mm)							TC	Screw	Insert
		h	b	S	Tmax	f	L	KG			
D658	1212 2C-R MGM	12	12	2	16	12	125	0,162	TC131	4 Allen	
D660	1616 2C-R MGM	16	16	2	16	16	125	0,250	TC131	4 Allen	MGM 200
D662	2020 2C-R MGM	20	20	2	16	20	125	0,404	TC132	4 Allen	KRLY
D664	2525 2C-R MGM	25	25	2	16	25	150	0,726	TC134	5 Allen	
D666	3232 2C-R MGM	32	32	2	16	32	170	1,349	TC134	5 Allen	
D667	1212 3C-R MGM	12	12	3	18	12	125	0,162	TC131	4 Allen	
D668	1616 3C-R MGM	16	16	3	18	16	125	0,268	TC131	4 Allen	MGM 300
D670	2020 3C-R MGM	20	20	3	18	20	125	0,407	TC132	4 Allen	KRLY
D672	2525 3C-R MGM	25	25	3	18	25	150	0,727	TC134	5 Allen	
D674	3232 3C-R MGM	32	32	3	18	32	170	1,280	TC134	5 Allen	
D675	1616 4C-R MGM	16	16	4	18	16	125	0,273	TC131	4 Allen	
D676	2020 4C-R MGM	20	20	4	18	20	125	0,408	TC132	4 Allen	MGM 400
D678	2525 4C-R MGM	25	25	4	18	25	150	0,727	TC134	5 Allen	KRLY
D680	3232 4C-R MGM	32	32	4	20	32	170	1,287	TC134	5 Allen	
D682	2020 5C-R MGM	20	20	5	25	20	125	0,391	TC132	4 Allen	MGM 500
D684	2525 5C-R MGM	25	25	5	25	25	150	0,703	TC134	5 Allen	KRLY
D686	3232 5C-R MGM	32	32	5	25	32	170	1,268	TC136	6 Allen	
D687	2525 6C-R MGM	25	25	6	27	25	150	0,745	TC134	5 Allen	MGM 600 KRLY

*Compatible with / Kompatibel für (KRLY)*

MGM/L

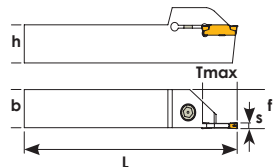
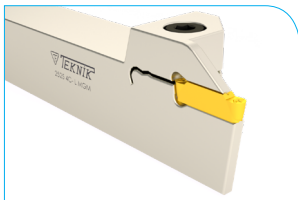

Order Code	Product Code	Dimensions (mm)							TC	Screw	Insert
		h	b	S	Tmax	f	L	KG			
D607	1212 2C-L MGM	12	12	2	16	12	125	0,161	TC131	4 Allen	MGM 200
D608	1616 2C-L MGM	16	16	2	16	16	125	0,250	TC131	4 Allen	KRLY
D610	2020 2C-L MGM	20	20	2	16	20	125	0,404	TC132	4 Allen	
D611	2525 2C-L MGM	25	25	2	16	25	150	0,726	TC134	5 Allen	
D612	1616 3C-L MGM	16	16	3	18	16	125	0,268	TC131	4 Allen	MGM 300
D614	2020 3C-L MGM	20	20	3	18	20	125	0,407	TC132	4 Allen	KRLY
D615	2525 3C-L MGM	25	25	3	18	25	150	0,750	TC134	5 Allen	
D617	2020 4C-L MGM	20	20	4	18	20	125	0,407	TC132	4 Allen	MGM 400
D618	2525 4C-L MGM	25	25	4	18	25	150	0,727	TC134	5 Allen	KRLY
D620	2525 5C-L MGM	25	25	5	25	25	150	0,703	TC134	5 Allen	MGM 500 KRLY
D621	2525 6C-L MGM	25	25	5	27	25	150	0,745	TC134	5 Allen	MGM 600 KRLY

*Compatible with / Kompatibel für (KRLY)*

MGM/R

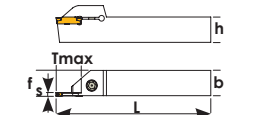
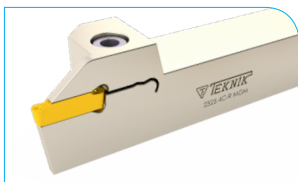

Order Code	Product Code	Dimensions (mm)							TC	Screw	Insert
		h	b	S	Tmax	f	L	KG			
D960	2525 3C-R MGM	25	25	3	25	25	150	0,727	TC134	5 Allen	MGM 300
D963	2525 3C-R MGM	25	25	3	40	25	170	0,722	TC134	5 Allen	KRLY
D961	2525 4C-R MGM	25	25	4	25	25	150	0,727	TC134	5 Allen	MGM 400
D964	2525 4C-R MGM	25	25	4	40	25	170	0,721	TC134	5 Allen	KRLY
D962	2525 5C-R MGM	25	25	5	40	25	170	0,745	TC134	5 Allen	MGM 500 KRLY

*Compatible with / Kompatibel für (KRLY)*

External Threading Toolholders Sliding Automatic Lathes

MGMN	Order Code	Product Code	Dimensions (mm)							TC076	T15	MGMN 200 KRLY
			h	b	S	Tmax	f	L	kg			
	D010	1212 2C MGMN 200	12	12	2	12	12,2	125	0,166	TC076	T15	MGMN 200 KRLY
	D011	1616 2C MGMN 200	16	16	2	16	16,2	125	0,267	TC076	T15	MGMN 200 KRLY
	D013	1212 3C MGMN 300	12	12	3	12	12,3	125	0,166	TC076	T15	MGMN 300 KRLY
	D014	1616 3C MGMN 300	16	16	3	16	16,3	125	0,267	TC076	T15	MGMN 300 KRLY
<i>Compatible with / Kompatible für (KRLY)</i>												

MGMN/L	Order Code	Product Code	Dimensions (mm)							TC076	T15	MGMN 200 KRLY
			h	b	S	Tmax	f	L	kg			
	D054	1212 2C-L MGMN 200	12	12	2	12	12,2	125	0,166	TC076	T15	MGMN 200 KRLY
	D055	1616 2C-L MGMN 200	16	16	2	16	16,2	125	0,267	TC076	T15	MGMN 200 KRLY
	D056	1212 3C-L MGMN 300	12	12	3	12	12,3	125	0,166	TC076	T15	MGMN 300 KRLY
	D057	1616 3C-L MGMN 300	16	16	3	16	16,3	125	0,267	TC076	T15	MGMN 300 KRLY
<i>Compatible with / Kompatible für (KRLY)</i>												

External Threading Toolholders Sliding Automatic Lathes

KGMN	Order Code	Product Code	Dimensions (mm)							TC076	T15	KGMN 200 KRLY
			h	b	S	Tmax	f	L	kg			
	D016	1212 2C KGMN 200	12	12	2	12	12,2	125	0,166	TC076	T15	KGMN 200 KRLY
	D017	1616 2C KGMN 200	16	16	2	16	16,2	125	0,267	TC076	T15	KGMN 200 KRLY
<i>Compatible with / Kompatible für (KRLY)</i>												

KGMN/L	Order Code	Product Code	Dimensions (mm)							TC076	T15	KGMN 200 KRLY
			h	b	S	Tmax	f	L	kg			
	D058	1212 2C-L KGMN 200	12	12	2	12	12,2	125	0,166	TC076	T15	KGMN 200 KRLY
	D059	1616 2C-L KGMN 200	16	16	2	16	16,2	125	0,267	TC076	T15	KGMN 200 KRLY
<i>Compatible with / Kompatible für (KRLY)</i>												

KGMN /R	Order Code	Product Code	Dimensions (mm)							TC132	4 Allen	KGMN 200
			h	b	S	Tmax	f	L	kg			
	D635	2020 2C-R KGMN	20	20	2	18	20	125	0,412	TC132	4 Allen	KGMN 200
	D636	2525 2C-R KGMN	25	25	2	18	25	150	0,726	TC134	5 Allen	KRLY
	D637	2020 3C-R KGMN	20	20	3	20	20	125	0,406	TC132	4 Allen	KGMN 300
	D638	2525 3C-R KGMN	25	25	3	22	25	150	0,732	TC134	5 Allen	KRLY
	D639	2020 4C-R KGMN	20	20	4	20	20	125	0,406	TC132	4 Allen	KGMN 400
	D640	2525 4C-R KGMN	25	25	4	22	25	152	0,737	TC134	5 Allen	KRLY
	<i>Compatible with / Kompatible für (KRLY)</i>											

KGMN	Order Code	Product Code	Dimensions (mm)							TC132	4 Allen	KGMN 200
			h	b	S	Tmax	f	L	kg			
	D622	2020 2C KGMN	20	20	2	3,5	23,5	125	0,412	TC132	4 Allen	KGMN 200
	D623	2525 2C KGMN	25	25	2	3,5	28,5	150	0,833	TC134	5 Allen	KRLY
	D624	2020 3C KGMN	20	20	3	5	25	125	0,468	TC132	4 Allen	KGMN 300
	D625	2525 3C KGMN	25	25	3	5	30	150	0,837	TC134	5 Allen	KRLY
	D626	2020 4C KGMN	20	20	4	5	25	125	0,463	TC132	4 Allen	KGMN 400
	D627	2525 4C KGMN	25	25	4	5	30	150	0,464	TC134	5 Allen	KRLY
	<i>Compatible with / Kompatible für (KRLY)</i>											

**ISCR/R**

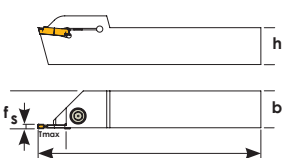
Order Code	Product Code	Dimensions (mm)							TC	Allen	ISCR
		h	b	S	Tmax	f	L	kg			
D750	1212 2C-R DGN	12	12	2	16	12	125	0,158	TC131	4 Allen	
D752	1616 2C-R DGN	16	16	2	16	16	125	0,260	TC131	4 Allen	DGN 2C
D754	2020 2C-R DGN	20	20	2	18	20	125	0,398	TC132	4 Allen	ISCR
D756	2525 2C-R DGN	25	25	2	19	25	150	0,712	TC134	5 Allen	
D758	1212 3C-R DGN	12	12	3	16	12	125	0,160	TC131	4 Allen	
D760	1616 3C-R DGN	16	16	3	19	16	125	0,253	TC131	4 Allen	DGN 3C
D762	2020 3C-R DGN	20	20	3	20	20	125	0,394	TC132	4 Allen	ISCR
D764	2525 3C-R DGN	25	25	3	22	25	150	0,711	TC134	5 Allen	
D764-1	2525 3C-R DGN	25	25	3	25	25	150	0,711	TC134	5 Allen	
D775	2020 4C-R DGN	20	20	4	20	20	125	0,391	TC132	4 Allen	DGN 4C
D777	2525 4C-R DGN	25	25	4	20	25	150	0,709	TC134	5 Allen	ISCR

Compatible with / Kompatibel für (ISCR)

**ISCR/L**



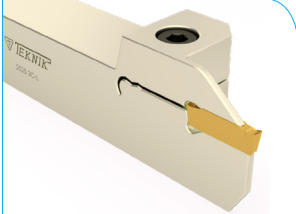
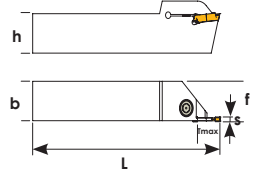

Order Code	Product Code	Dimensions (mm)							TC	Allen	ISCR
		h	b	S	Tmax	f	L	kg			
D726	1212 2C-L DGN	12	12	2	16	12	125	0,158	TC131	4 Allen	DGN 2C
D727	1616 2C-L DGN	16	16	2	16	16	125	0,260	TC131	4 Allen	ISCR
D728	2020 2C-L DGN	20	20	2	18	20	125	0,398	TC132	4 Allen	
D729	2525 2C-L DGN	25	25	2	19	25	150	0,712	TC134	5 Allen	
D730	1212 3C-L DGN	12	12	3	16	12	125	0,160	TC131	4 Allen	DGN 3C
D731	1616 3C-L DGN	16	16	3	19	16	125	0,253	TC131	4 Allen	ISCR
D732	2020 3C-L DGN	20	20	3	20	20	125	0,394	TC132	4 Allen	
D733	2525 3C-L DGN	25	25	3	22	25	150	0,711	TC134	5 Allen	

Compatible with / Kompatibel für (ISCR)

**External Threading Toolholders Sliding Automatic Lathes**

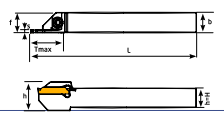

**DGN**

Order Code	Product Code	Dimensions (mm)							TC	Allen	ISCR
		h	b	S	Tmax	f	L	kg			
D019	1212 2C DGN	12	12	2	12	12,2	125	0,166	TC076	T15	DGN 2C ISCR
D020	1616 2C DGN	16	16	2	16	16,2	125	0,267	TC076	T15	DGN 2C ISCR
D021	1212 3C-DGN	12	12	3	12	12,3	125	0,166	TC076	T15	DGN 3C ISCR
D022	1616 3C-DGN	16	16	3	16	16,3	125	0,267	TC076	T15	DGN 3C ISCR

Compatible with / Kompatibel für (ISCR)

**DGN/L**

Order Code	Product Code	Dimensions (mm)							TC	Allen	ISCR
		h	b	S	Tmax	f	L	kg			
D062	1212 2C-L DGN	12	12	2	12	12,2	125	0,166	TC076	T15	DGN 2C ISCR
D063	1616 2C-L DGN	16	16	2	16	16,2	125	0,267	TC076	T15	DGN 2C ISCR
D064	1212 3C-L DGN	12	12	3	12	12,3	125	0,166	TC076	T15	DGN 3C ISCR
D065	1616 3C-L DGN	16	16	3	16	16,3	125	0,267	TC076	T15	DGN 3C ISCR

Compatible with / Kompatibel für (ISCR)

**DCEN**



Order Code	Product Code	Dimensions (mm)						kg			
		h	b	S	Tmax	f	L				
D744	2020 DCEN 300	20	20	3	22	20	125	0,409	M4x30	3 Allen	DCEN 300
D745	2525 DCEN 300	25	25	3	22	25	150	0,755	M4x30	3 Allen	ISCR

Compatible with / Kompatible für (ISCR)

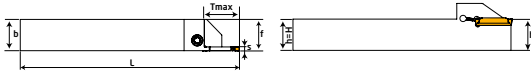

**GRP/R**

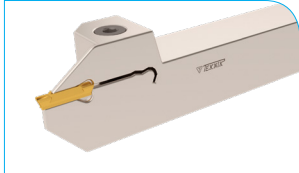

Order Code	Product Code	Dimensions (mm)						kg			
		h	b	S	Tmax	f	L				
D773	2020 3C-R GRP	20	20	3	18	20	125	0,409	TC132	4 Allen	GRP 3C
D769	2525 3C-R GRP	25	25	3	18	25	150	0,755	TC134	5 Allen	ISCR
D770	2525 4C-R GRP	25	25	4	20	25	150	0,747	TC134	5 Allen	GRP 4C
D772	3232 4C-R GRP	32	32	4	18	32	170	1,285	TC134	5 Allen	ISCR
D771	2525 5C-R GRP	25	25	5	24	25	150	0,739	TC134	5 Allen	GRP 5C
D774	3232 5C-R GRP	32	32	5	24	32	170	1,264	TC134	5 Allen	ISCR

Compatible with / Kompatible für (ISCR)

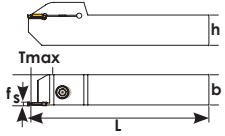

**PHCR**



Order Code	Product Code	Dimensions (mm)				kg			
		L	h	b					
D966	PHCR 12-24 PNT	120	12	12		0,136	TC084-1	T20	24 PNT
D968	PHCR 16-24 PNT	120	16	16		0,232	TC084-1	T20	ISCR
D970	PHCR 20-24 PNT	125	20	20		0,377	TC084-1	T20	24 PNT
D972	PHCR 25-24 PNT	150	25	25		0,706	TC084-1	T20	ISCR
D974	PHCR 20-34 PNT	125	20	20		0,376	TC084-1	T20	34 PNT
D976	PHCR 25-34 PNT	150	25	25		0,695	TC084-1	T20	ISCR

Compatible with / Kompatible für (ISCR)

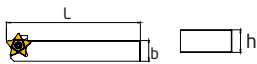

**K.HRN/R S224**

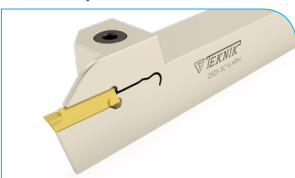

Order Code	Product Code	Dimensions (mm)						kg			
		h	b	S	Tmax	f	L				
D700	1616 2C-R S224	16	16	2	18	16	125	0,258	TC131	4 Allen	2C S224
D701	2020 2C-R S224	20	20	2	18	20	125	0,406	TC132	4 Allen	K.HRN
D702	2525 2C-R S224	25	25	2	18	25	150	0,713	TC134	5 Allen	
D703	1616 3C-R S224	16	16	3	18	16	100	0,260	TC131	4 Allen	3C S224
D704	2020 3C-R S224	20	20	3	18	20	125	0,407	TC132	4 Allen	K.HRN
D705	2525 3C-R S224	25	25	3	18	25	150	0,720	TC134	5 Allen	
D706	2020 4C-R S224	20	20	4	18	20	125	0,401	TC132	4 Allen	4C S224
D707	2525 4C-R S224	25	25	4	18	25	150	0,737	TC134	5 Allen	K.HRN
D708	2020 5C-R S224	20	20	5	18	20	125	0,401	TC132	4 Allen	5C S224
D710	2525 5C-R S224	25	25	5	18	25	150	0,730	TC134	5 Allen	K.HRN

Compatible with / Kompatible für (HRN)

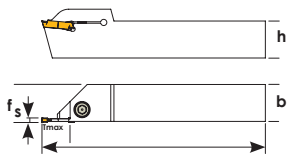

**B.HRN/R S229**



Order Code	Product Code	Dimensions (mm)						kg			
		h	b	S	Tmax	f	L				
D688	2020 3C-R S229	20	20	3	22	20	125	0,391	TC132	4 Allen	3C S229
D690	2525 3C-R S229	25	25	3	22	25	150	0,700	TC134	5 Allen	B.HRN
D692	2020 4C-R S229	20	20	4	22	20	125	0,386	TC132	4 Allen	4C S229
D694	2525 4C-R S229	25	25	4	22	25	150	0,705	TC134	5 Allen	B.HRN
D696	2020 5C-R S229	20	20	5	22	20	125	0,389	TC132	4 Allen	5C S229
D698	2525 5C-R S229	25	25	5	22	25	150	0,709	TC134	5 Allen	B.HRN

Compatible with / Kompatible für (HRN)

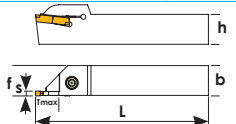

**B.HRN/L S229**

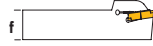
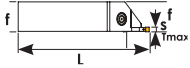
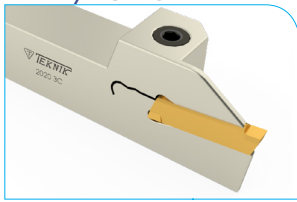

Order Code	Product Code	Dimensions (mm)							TC	Allen	Insert
		h	b	S	Tmax	f	L	kg			
D711	2525 3C-L S229	25	25	3	22	25	150	0,700	TC134	5 Allen	3C S229 B.HRN
D712	2525 4C-L S229	25	25	4	22	25	150	0,705	TC134	5 Allen	4C S229 B.HRN
D713	2525 5C-L S229	25	25	5	22	25	150	0,709	TC134	5 Allen	5C S229 B.HRN

Compatible with/ Kompatibel für (HRN)

**SDV 123/R**

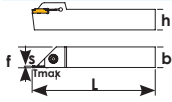

Order Code	Product Code	Dimensions (mm)							TC	Allen	Insert
		h	b	S	Tmax	f	L	kg			
D900	2020 2C-123 SDV-R	20	20	2	18	20	125	0,400	TC132	4 Allen	123 2C
D902	2525 2C-123 SDV-R	25	25	2	18	25	150	0,732	TC134	5 Allen	SDV
D904	2020 3C-123 SDV-R	20	20	3	19	20	125	0,397	TC132	4 Allen	123 3C
D906	2525 3C-123 SDV-R	25	25	3	20	25	150	0,713	TC134	5 Allen	SDV
D908	2020 4C-123 SDV-R	20	20	4	18	20	125	0,415	TC132	4 Allen	123 4C
D910	2525 4C-123 SDV-R	25	25	4	18	25	150	0,724	TC134	5 Allen	SDV
D912	2525 5C-123 SDV-R	25	25	5	18	25	150	0,725	TC134	5 Allen	123 SDV 5C

Compatible with / Kompatibel für (SDVC)

**SDV 123/L**

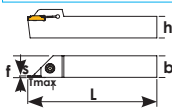

Order Code	Product Code	Dimensions (mm)							TC	Allen	Insert
		h	b	S	Tmax	f	L	kg			
D873	2020 2C-123 SDV-L	20	20	2	18	20	125	0,400	TC132	4 Allen	123 2C
D874	2525 2C-123 SDV-L	25	25	2	18	25	150	0,732	TC134	5 Allen	SDV
D875	2020 3C-123 SDV-L	20	20	3	19	20	125	0,397	TC132	4 Allen	123 3C
D876	2525 3C-123 SDV-L	25	25	3	20	25	150	0,713	TC134	5 Allen	SDV
D877	2020 4C-123 SDV-L	20	20	4	18	20	125	0,415	TC132	4 Allen	123 4C
D878	2525 4C-123 SDV-L	25	25	4	18	25	150	0,724	TC134	5 Allen	SDV
D879	2525 5C-123 SDV-L	25	25	5	18	25	150	0,725	TC134	5 Allen	123 5C SDV

Compatible with / Kompatibel für (SDVC)

**DGM 2-3**

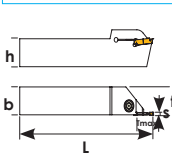

Order Code	Product Code	Dimensions (mm)							TC	Allen	Insert
		h	b	S	Tmax	f	L	kg			
D842	1212 2C-DGM 2	12	12	2	16	12	125	0,166	TC131	4 Allen	
D843	1616 2C-DGM 2	16	16	2	17	16	125	0,267	TC131	4 Allen	DGM 2C
D844	2020 2C-DGM 2	20	20	2	17	20	125	0,403	TC132	4 Allen	TNGLY
D845	2525 2C-DGM 2	25	25	2	17	25	150	0,739	TC134	5 Allen	
D847	1212 3C-DGM 3	12	12	3	16	12	125	0,168	TC132	4 Allen	
D848	1616 3C-DGM 3	16	16	3	17	16	125	0,263	TC132	4 Allen	DGM 3C
D849	2020 3C-DGM 3	20	20	3	20	20	125	0,395	TC132	4 Allen	TNGLY
D850	2525 3C-DGM 3	25	25	3	20	25	150	0,740	TC134	5 Allen	

Compatible with / Kompatibel für (TNGLY)

**GX16-GX24**

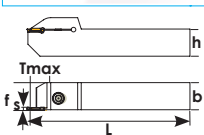

**NEW PRODUCT**

Order Code	Product Code	Dimensions (mm)							TC	Allen	Insert
		h	b	S	Tmax	f	L	kg			
D858	2020 2C GX16	20	20	2	18	20	125	0,267	TC132	4 Allen	GX 16 2C WLTR
D859	2525 2C GX16	25	25	2	18	25	150	0,403	TC134	5 Allen	GX 16 2C WLTR
D860	2020 3C GX16	20	20	3	20	20	125	0,395	TC132	4 Allen	GX 16 3C WLTR
D861	2525 3C GX16	25	25	3	22	25	150	0,740	TC134	5 Allen	GX 16 3C WLTR
D864	2020 2C GX24	20	20	2	18	20	125	0,403	TC132	4 Allen	GX 24 2C WLTR
D865	2525 2C GX24	25	25	2	18	25	150	0,739	TC134	5 Allen	GX 24 2C WLTR
D866	2020 3C GX24	20	20	3	20	20	125	0,395	TC132	4 Allen	GX 24 3C WLTR
D867	2525 3C GX24	25	25	3	22	25	150	0,740	TC134	5 Allen	GX 24 3C WLTR

Compatible with/ Kompatibel für (WLTR)

ZCC/R ZT-D

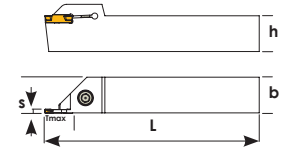
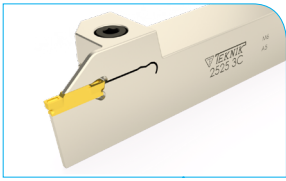

Order Code	Product Code	Dimensions (mm)									
		h	b	S	Tmax	f	L				
D027	1616 3C-R ZT-D	16	16	3	18	16	125	0,301	TC131	4 Allen	ZT.D 3C
D028	2020 3C-R ZT-D	20	20	3	18	20	125	0,394	TC132	4 Allen	ZCC
D030	2525 3C-R ZT-D	25	25	3	22	25	150	0,755	TC134	5 Allen	
D036	2020 4C-R ZT-D	20	20	4	18	20	125	0,400	TC132	4 Allen	ZT.D 4C
D038	2525 4C-R ZT-D	25	25	4	22	25	150	0,747	TC134	5 Allen	ZCC
D044	2020 5C-R ZT-D	20	20	5	18	20	125	0,391	TC132	4 Allen	ZT.D 5C
D046	2525 5C-R ZT-D	25	25	5	18	25	150	0,734	TC134	5 Allen	ZCC
D049	2525 6C-R ZT-D	25	25	6	18	25	150	0,745	TC134	5 Allen	ZT.D 6C
D051	3232 6C-R ZT-D	32	32	6	20	32	170	1,331	TC134	5 Allen	ZCC

Compatible with ZCC/ Kompatible für (ZCC)

TKT/R TD

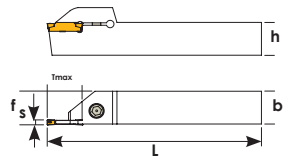

Order Code	Product Code	Dimensions (mm)									
		h	b	S	Tmax	f	L				
D714	1212 2C-R TD	12	12	2	16	12	125	0,166	TC131	4 Allen	TD 2C
D715	1616 2C-R TD	16	16	2	16	16	125	0,270	TC131	4 Allen	TGTC
D716	2020 2C-R TD	20	20	2	16	20	125	0,401	TC132	4 Allen	
D717	2525 2C-R TD	25	25	2	18	25	150	0,728	TC134	5 Allen	
D718	1212 3C-R TD	12	12	2	16	12	125	0,160	TC131	4 Allen	
D719	1616 3C-R TD	16	16	3	18	16	125	0,256	TC131	4 Allen	TD 3C
D720	2020 3C-R TD	20	20	3	18	20	125	0,398	TC132	4 Allen	TGTC
D721	2525 3C-R TD	25	25	3	18	25	150	0,735	TC134	5 Allen	
D722	2020 4C-R TD	20	20	4	18	20	125	0,401	TC132	4 Allen	TD 4C
D723	2525 4C-R TD	25	25	4	18	25	150	0,735	TC134	5 Allen	TGTC

Compatible with. / Kompatible für (TGTC)

Block for Blades

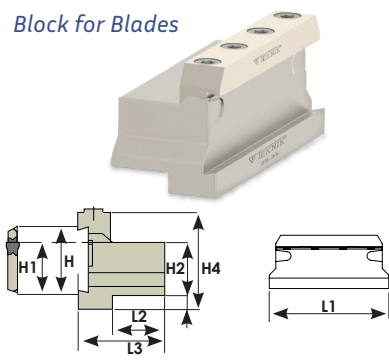

Order Code	Product Code	Dimensions (mm)					
		H	L1	L2	H1	H2	L3
KLT04	20-26	26	87	19	21,4	20	33
KLT05	25-26	26	110	20	24,4	25	34
KLT06	20-32	32	110	19	25	20	35
KLT08	25-32	32	110	20	25	25	36
KLT10	32-32	32	110	28	25	32	44



**MGMN**

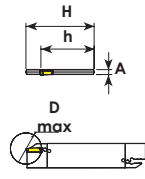
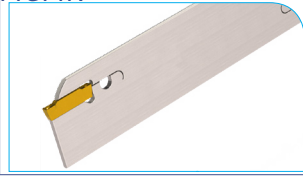

Order Code	Product Code	Dimensions (mm)					Insert
		H	h	A	L	D max	
KL29	32-2	32	25	2	150		MGMN 200 KRLY
KL30	32-3	32	25	2,45	150		MGMN 300 KRLY
KL32	32-4	32	25	3,45	150		MGMN 400 KRLY

**KGMN**

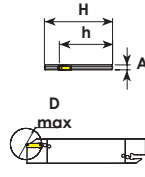
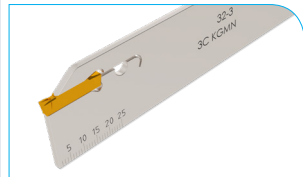

Order Code	Product Code	Dimensions (mm)					Insert
		H	h	A	L	D max	
KL37	26-2	26	21,4	1,65	110		KGMN 200 KRLY
KL38	26-3	26	21,4	2,45	110		KGMN 300 KRLY
KL39	26-4	26	21,4	3,45	110		KGMN 400 KRLY
KL34	32-2	32	25	1,65	150		KGMN 200 KRLY
KL35	32-3	32	25	2,45	150		KGMN 300 KRLY
KL36	32-4	32	25	3,45	150		KGMN 400 KRLY

**SP**

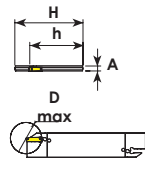
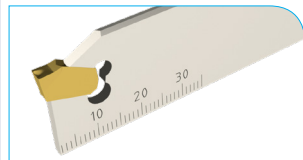

Order Code	Product Code	Dimensions (mm)					Insert
		H	h	A	L	D max	
KL40	26-3	26	21,4	2,45	110		SP 300 KRLY
KL42	26-4	26	21,4	3,45	110		SP 400 KRLY
KL44	32-3	32	25	2,45	150		SP 300 KRLY
KL45	32-4	32	25	3,45	150		SP 400 KRLY

**N151-3**

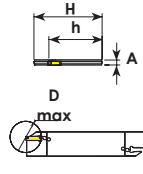
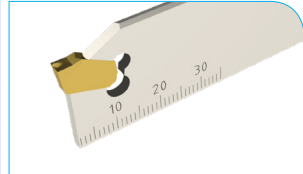

Order Code	Product Code	Dimensions (mm)					Insert
		H	h	A	L	D max	
KL52	26-3	26	21,4	2,45	110		N151-3 SDV
KL54	26-4	26	21,4	3,45	110		N151-4 SDV
KL56	32-3	32	25	2,45	150		N151-3 SDV
KL58	32-4	32	25	3,45	150		N151-4 SDV

**SDV 123**

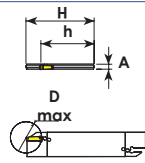
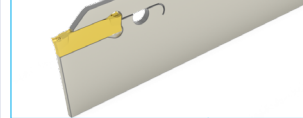

Order Code	Product Code	Dimensions (mm)					Insert
		H	h	A	L	D max	
KL60	32-3	32	25	2,45	150		123 3C SDV
KL61	32-4	32	25	3,45	150		123 4C SDV

**DGN**

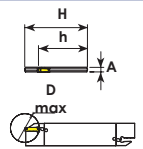

Order Code	Product Code	Dimensions (mm)					Insert
		H	h	A	L	D max	
KL17	26-2	25,3	21	1,8	110		DGN2 ISC
KL18	26-3	25,3	21	2,4	110		DGN3 ISC
KL20	32-3	32	25	2,45	150		DGN3 ISC
KL22	32-4	32	25	3,45	150		DGN4 ISC

**GTN**

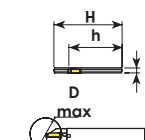
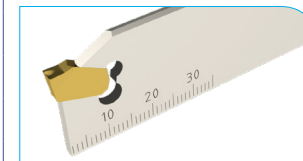

Order Code	Product Code	Dimensions (mm)					Insert
		H	h	A	L	D max	
KL23	26-3	26	21,4	2,45	110		GTN3 ISC
KL24	26-4	26	21,4	3,45	110		GTN4 ISC
KL25	32-3	32	25	2,45	150		GTN3 ISC
KL26	32-4	32	25	3,45	150		GTN4 ISC



## Grooving Bars



[www.teknikcuttingtools.com](http://www.teknikcuttingtools.com)



Kalite için **TEKNIK** çözüm  
Technical solution for quality

138-141



MGM/R

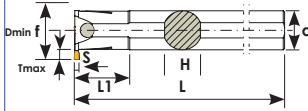

Order Code	Product Code	Dimensions (mm)												
		Dmin	Tmax	L	L1	d	h	f	s					
K600	S16Q 2C-R MGM	21	5	180	35	16	15	12,5	2	0,288	TC130	4 Allen	MGM 200	
K602	S20Q 2C-R MGM	26	5,7	180	35	20	18	15,5	2	0,440	TC130	4 Allen	KRLY	
K603	S25R 2C-R MGM	31	5,7	200	35	25	23	18	2	0,787	TC131	4 Allen		
K604	S20Q 3C-R MGM	26	6	180	35	20	18	15,5	3	0,450	TC130	4 Allen		
K606	S25R 3C-R MGM	32	6,7	200	40	25	23	19	3	0,784	TC131	4 Allen	MGM 300	
K608	S32S 3C-R MGM	38	6,1	250	60	32	30	21,5	3	1,555	TC134	5 Allen	KRLY	
K609	S40T 3C-R MGM	48	7,2	300	60	40	38	27	3	2,940	TC134	5 Allen		
K610	S20Q 4C-R MGM	26	6	180	35	20	18	15,5	4	0,443	TC130	4 Allen		
K612	S25R 4C-R MGM	31	6	200	40	25	23	18,2	4	0,783	TC131	4 Allen	MGM 400	
K614	S32S 4C-R MGM	38	6	250	65	32	30	21,5	4	1,552	TC134	5 Allen	KRLY	
K616	S40T 4C-R MGM	47	7,2	300	60	40	38	27	4	2,942	TC134	5 Allen		
K618	S25R 5C-R MGM	32	7	200	40	25	23	19,2	5	0,777	TC131	4 Allen	MGM 500	
K620	S32S 5C-R MGM	39	7	250	60	32	30	22,5	5	1,561	TC134	5 Allen	KRLY	
K622	S40T 5C-R MGM	47	7,4	300	60	40	38	27	5	2,936	TC134	5 Allen		

Compatible with / Kompatibel für (KRLY)

MGM/L

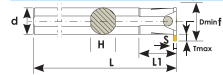

Order Code	Product Code	Dimensions (mm)												
		Dmin	Tmax	L	L1	d	h	f	s					
K897	S16Q 2C-L MGM	21	5	180	35	16	15	12,5	2	0,288	TC130	4 Allen	MGM 200 KRLY	
K900	S20Q 3C-L MGM	26	6	180	35	20	18	15,5	3	0,450	TC130	4 Allen	MGM 300	
K902	S25R 3C-L MGM	32	6,7	200	40	25	23	19	3	0,784	TC131	4 Allen	KRLY	
K904	S20Q 4C-L MGM	26	6	180	35	20	18	15,5	4	0,443	TC130	4 Allen	MGM 400	
K906	S25R 4C-L MGM	31	6	200	40	25	23	18,2	4	0,783	TC131	4 Allen	KRLY	

Compatible with / Kompatibel für (KRLY)

KGMN

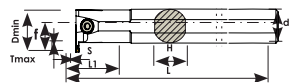

Order Code	Product Code	Dimensions (mm)												
		Dmin	Tmax	L	L1	d	h	f	s					
K660	S16K 2C KGMN	23	6,5	125	35	16	15	14	2	0,220	TC130	4 Allen	KGMN 200	
K661	S20M 2C KGMN	25	6,5	150	45	20	18	15,5	2	0,374	TC130	4 Allen	KRLY	
K662	S25R 2C KGMN	32	7	200	45	25	23	19	2	0,802	TC131	5 Allen		
K663	S20M 3C KGMN	25	6,5	150	45	20	18	15,5	3	0,370	TC130	4 Allen	KGMN 300	
K664	S25R 3C KGMN	32	7	200	45	25	23	19	3	0,800	TC131	5 Allen	KRLY	
K665	S32S 3C KGMN	40	7,5	250	55	32	30	22,5	3	1,627	TC134	5 Allen		
K666	S20M 4C KGMN	25	6,5	150	45	20	18	15,5	4	0,374	TC130	4 Allen	KGMN 400	
K667	S25R 4C KGMN	32	7	200	45	25	23	19	4	0,796	TC131	5 Allen	KRLY	
K668	S32S 4C KGMN	40	7,5	250	55	32	30	22,5	4	1,623	TC134	5 Allen		

Compatible with / Kompatibel für (KRLY)

HRN/R S229

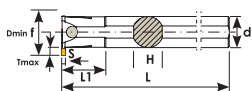

Order Code	Product Code	Dimensions (mm)												
		Dmin	Tmax	L	L1	d	h	f	s					
K624	S25R 3C-R S229	34	9,8	200	50	25	23	21,5	3	0,766	TC131	4 Allen	3C S229	
K626	S32S 3C-R S229	41	9	250	50	32	30	24,5	3	1,560	TC134	5 Allen	B.HRN	
K628	S40T 3C-R S229	49	9	300	50	40	38	21,5	3	2,594	TC134	5 Allen		
K630	S25R 4C-R S229	34	9,8	200	50	25	23	24,5	4	0,768	TC131	4 Allen	4C S229	
K632	S32S 4C-R S229	42	9	250	50	32	30	23,5	4	1,656	TC134	5 Allen	B.HRN	
K634	S40T 4C-R S229	49	9	300	50	40	38	28,5	4	3,113	TC134	5 Allen		
K636	S25R 5C-R S229	33	9,5	200	50	25	23	21	5	0,770	TC131	4 Allen	5C S229	
K638	S32S 5C-R S229	41	9	250	50	32	30	24,5	5	1,659	TC134	5 Allen	B.HRN	
K640	S40T 5C-R S229	49	9	300	50	40	38	28,5	5	3,109	TC134	5 Allen		

Compatible with / Kompatibel für (HRN)



Order Code	Product Code	Dimensions (mm)												
		Dmin	Tmax	L	L1	d	h	f	s					
K720	S25R 3C-R-123 SDV	32	7	200	40	25	23	19,5	3	0,784	TC131	4 Allen	123 3C	
K722	S32S 3C-R-123 SDV	39	7	250	60	32	30	23	3	1,567	TC134	5 Allen	SNDVK	
K726	S25R 4C-R-123 SDV	32	7	200	40	25	23	19,5	4	0,772	TC131	4 Allen	123 4C	
K728	S32S 4C-R-123 SDV	39	7	250	60	32	30	23	4	2,854	TC134	5 Allen	SNDVK	
K730	S25S 5C-R-123 SDV	32	7	200	40	25	23	19,5	5	0,785	TC131	4 Allen	123 5C	
K732	S32S 5C-R-123 SDV	39	7	250	60	32	30	19,5	5	1,564	TC134	5 Allen	SNDVK	

Compatible with. / Kompatible für (SNDVK)

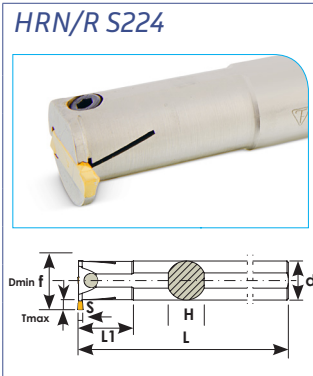

Order Code	Product Code	Dimensions (mm)												
		Dmin	Tmax	L	L1	d	h	f	s					
K642	S20Q 2C-R S224	26	6,5	180	40	20	18	16	2	0,444	TC130	4 Allen	2C S224	
K644	S25R 2C-R S224	34	9	200	50	25	23	21	2	0,763	TC131	5 Allen	K.HRN	
K646	S20Q 3C-R S224	26	6,5	180	40	20	18	16	3	0,459	TC130	4 Allen	3C S224	
K648	S25R 3C-R S224	33	9	200	50	25	23	20,5	3	0,782	TC131	5 Allen	K.HRN	
K650	S32S 3C-R S224	40	9	250	50	32	30	24	3	1,633	TC134	5 Allen		
K652	S20Q 4C-R S224	26	6,5	180	40	20	18	16	4	0,440	TC130	4 Allen	4C S224	
K654	S25R 4C-R S224	33	9	200	50	25	23	20,5	4	0,764	TC131	5 Allen	K.HRN	
K656	S32S 4C-R S224	42	9	250	50	32	30	23,5	4	1,672	TC134	5 Allen		

Compatible with/ Kompatible für (HRN)



Order Code	Product Code	Dimensions (mm)												
		Dmin	Tmax	L	L1	d	h	f	s					
K679	S16Q 2C R ZT.D	20	4,9	180	35	16	15	12,5	2	0,446	TC130	4 Allen	ZT.D 2C ZCC	
K680	S20Q 3C-R ZT.D	26	5,5	180	35	20	18	15	3	0,661	TC130	4 Allen	ZT.D 3C	
K681	S25R 3C-R ZT.D	33	7,5	200	35	25	23	20	3	1,576	TC131	5 Allen	ZCC	
K682	S32S 3C-R ZT.D	39	7	250	50	32	30	23	3	1,641	TC134	5 Allen		
K684	S25R 4C-R ZT.D	33	7,5	200	35	25	23	20	4	1,578	TC131	5 Allen	ZT.D 4C	
K685	S32S 4C-R ZT.D	39	7	250	50	32	30	23	4	1,645	TC134	5 Allen	ZCC	

Compatible with ZCC/ Kompatible für (ZCC)



Order Code	Product Code	Dimensions (mm)												
		Dmin	Tmax	L	L1	d	h	f	s					
K672	S20Q 3C-R DGN	25	5,5	180	35	20	18	15,0	3	0,308	TC130	4 Allen	DGN 3C	
K673	S25R 3C-R DGN	31	6	200	40	25	23	18,5	3	0,463	TC131	5 Allen	ISCR	
K674	S32S 3C-R DGN	37	6	250	55	32	30	30	3	0,809	TC134	5 Allen		
K676	S20Q 4C-R DGN	25	5,5	180	35	20	18	18	4	0,463	TC130	4 Allen	DGN 4C	
K677	S25R 4C-R DGN	31	6	200	40	25	23	23	4	0,810	TC131	5 Allen	ISCR	
K678	S32S 4C-R DGN	37	6	250	55	32	30	30	4	1,655	TC134	5 Allen		

Compatible with / Kompatible für (ISCR)



Order Code	Product Code	Dimensions (mm)												
		Dmin	Tmax	L	L1	d	h	f	s					
K700	S16Q 3C-R GRP	21	4,9	180	45	16	18	12,5	3	0,308	TC130	4 Allen	GRP 3C	
K702	S20Q 3C-R GRP	26	6	180	35	20	18	15,7	3	0,463	TC130	4 Allen	ISCR	
K704	S25R 3C-R GRP	32	6,5	200	35	25	23	18,7	3	0,809	TC131	4 Allen		
K706	S20Q 4C-R GRP	26	5,5	180	35	20	18	15,2	4	0,463	TC130	4 Allen	GRP 4C	
K708	S25R 4C-R GRP	32	6,5	200	35	25	23	18,7	4	0,810	TC131	4 Allen	ISCR	
K710	S32S 4C-R GRP	38	6,5	250	60	32	30	22	4	1,655	TC134	5 Allen		

Compatible with / Kompatible für (ISCR)

Mini Grooving Holders

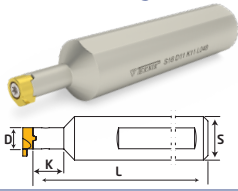

Order Code	Product Code	Dimensions (mm)					kg	TC	T	D
		S	D	K	L					
K801	S12 D5,9 K24 L080	12	5,9	24	80	0,143	TC063	T8	NFTG 08 KRLY	
K802	S12 D08 K33 L095	12	8	33	98	0,126	TC069	T10	NFTG 11 KRLY	
K803	S12 D09 K45 L110	12	9	45	110	0,120	TC074	T15	NFTG 14 KRLY	
K804	S12 D11 K48 L130	16	11	48	130	0,348	TC085	T20	NFTG 16 KRLY	

Compatible with / Kompatible für (KRLY)

Mini Grooving Holders

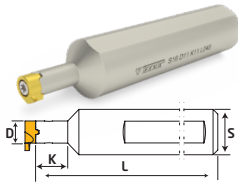

Order Code	Product Code	Dimensions (mm)					kg	TC	T	D
		S	D	K	L					
K810	S16 D08 K11 L093	16	8	11	93	0,098	TC069	T10	D08	
K812	S16 D09 K20 L093	16	9	20	93	0,102	TC074	T15	D09	
K814	S16 D06 K11 L081	16	6	11	81	0,082	TC063	T8	D06	
K816	S20 D14 K49 L160	20	14	49	160	0,367	TC085	T20	D14	

Grooving Holders

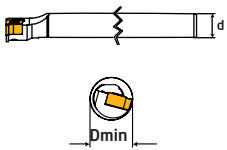
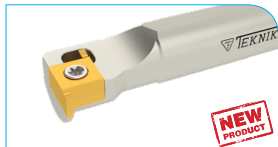

Order Code	Product Code	Dimensions (mm)								kg	TC	T	D
		Dmin	Tmax	L	L1	d	f	S					
K830	S08H L100 6GR	8,5	2	100	18	8	4,7	1-1,5-2	0,38	TC058-1	T6	6GR	
K831	S10K L125 7GR	12,5	2	125	25	10	6,8	1-1,5-2	0,74	TC058-2	T7	7GR	
K831-1	S10K L125 7GR	12,5	2	125	25	10	6,8	2	0,75	TC058-2	T7	7GR	
K832	S12M L150 7GR	15,5	2	150	25	12	8,6	1-1,5-2	0,128	TC058-2	T7	7GR	
K833	S10K L125 8GR	13,5	2	125	15	10	7,6	1-1,5	0,76	TC058-2	T7	8GR	
K834	S10K L125 8GR	13,5	2	125	15	10	7,6	2-2,5-3	0,77	TC058-2	T7	8GR	
K835	S12M L150 8GR	15,5	2	150	20	12	8,6	1-1,5	0,130	TC058-2	T7	8GR	
K836	S12M L150 8GR	15,5	2	150	20	12	8,6	2-2,5-3	0,130	TC058-2	T7	8GR	
K837	S16R L200 9GR	20	3,5	200	25	16	11,6	1-1,5	0,302	TC063	T8	9GR	
K838	S16R L200 9GR	20	3,5	200	25	16	11,6	2-2,5-3	0,302	TC063	T8	9GR	

Compatible with / Kompatible für - Sangeo - KC



MINI TOOL

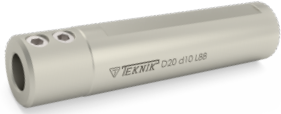

**NEW**  
PRODUCT

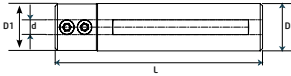

Order Code	Product Code	Dimensions (mm)						kg	M6x50	M6x8
		D	d	L	D1	kg				
DC304	D16 d03 L88	16	3	88	19,65	0,134		M6x50	M6x8	
DC306	D20 d03 L88	20	3	88	19,65	0,228		M6x50	M6x8	
DC310	D12 d04 L88	12	4	88	11,65	0,075		M6x50	M6x5	
DC312	D16 d04 L75	16	4	75	19,65	0,139		M6x35	M6x8	
DC314	D16 d04 L88	16	4	88	19,65	0,159		M6x50	M6x8	
DC316	D20 d04 L88	20	4	88	19,65	0,222		M6x50	M6x8	
DC318	D22 d04 L88	22	4	88	21,65	0,274		M6x50	M6x8	
DC320	D12 d05 L88	12	5	88	11,65	0,067		M6x50	M6x5	
DC322	D16 d05 L75	16	5	75	19,65	0,135		M6x35	M6x8	
DC324	D16 d05 L88	16	5	88	19,65	0,153		M6x50	M6x8	
DC326	D20 d05 L88	20	5	88	19,65	0,221		M6x50	M6x8	
DC328	D22 d05 L88	22	5	88	21,65	0,274		M6x50	M6x8	
DC334	D20 d06 L88	20	6	88	19,65	0,227		M6x50	M6x8	
DC340	D20 d07 L88	20	7	88	19,65	0,219		M6x50	M6x8	
DC344	D16 d08 L88	16	8	88	19,65	0,142		M6x50	M6x8	
DC346	D20 d08 L88	20	8	88	19,65	0,214		M6x50	M6x5	
DC350	D16 d10 L88	16	10	88	19,65	0,130		M6x50	M6x5	
DC352	D20 d10 L88	20	10	88	19,65	0,201		M6x50	M6x5	

ISO 40

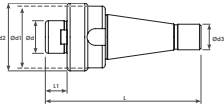

Order Code	Product Code	Şaft	Dimensions (mm)							kg
			d	d2	d1	d3	L	L1		
M206	ISO 40-16	ISO 40	16	54	38	25	154	17	1,232	
M208	ISO 40-22	ISO 40	22	54	50	25	154	19	1,371	
M210	ISO 40-27	ISO 40	27	55	59	25	154	21	1,413	
M212	ISO 40-32	ISO 40	32	61	67	25	154	24	1,750	
M214	ISO 40-40	ISO 40	40	61	73	25	154	27	1,956	

ISO 50

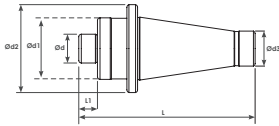

Order Code	Product Code	Şaft	Dimensions (mm)							kg
			d	d2	d1	d3	L	L1		
M216	ISO 50-22	ISO 50	22	98	52	39	196	19	3,640	
M218	ISO 50-27	ISO 50	27	98	61	39	196	21	3,976	
M220	ISO 50-32	ISO 50	32	98	68	39	196	24	3,817	
M222	ISO 50-40	ISO 50	40	98	98	39	196	27	4,512	
M224	ISO 50-60	ISO 50	60	108	108	39	196	26	5,562	

Kalite için TEKNİK çözüm  
Technical solution for quality



[www.teknikcuttingtools.com](http://www.teknikcuttingtools.com)

We do all  
we can  
to meet  
customers  
expectations.



## Spare Parts



[www.teknikcuttingtools.com](http://www.teknikcuttingtools.com)





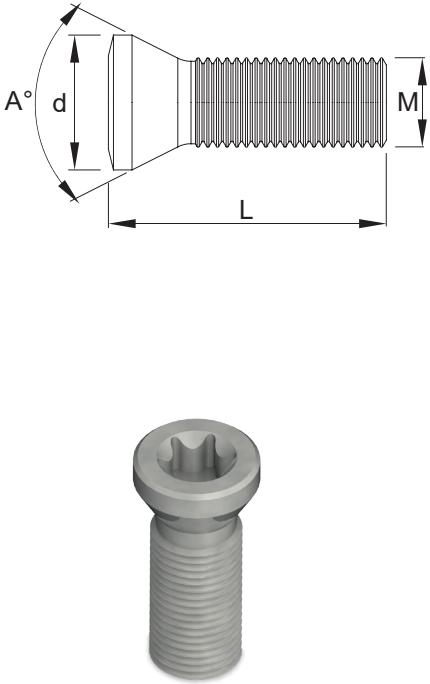
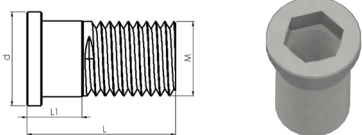

Kalite için TEKNİK çözüm  
Technical solution for quality

144-149

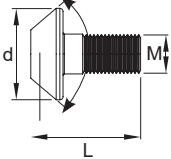
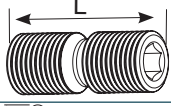
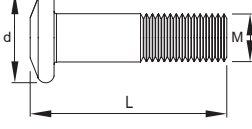
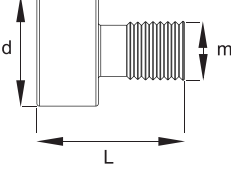
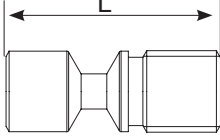









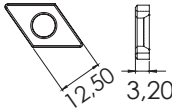

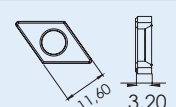



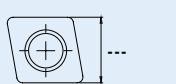

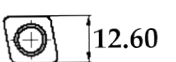

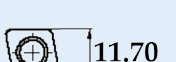



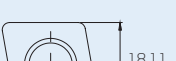



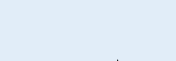

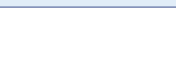



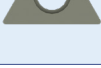
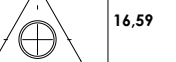



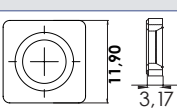

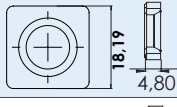

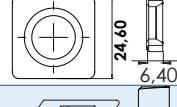
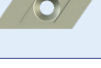
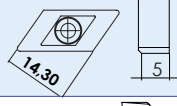

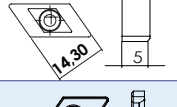

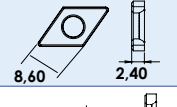
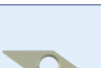
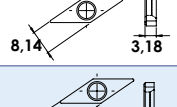

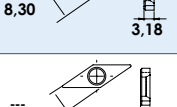

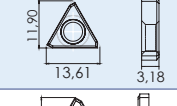

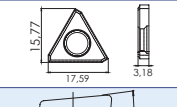



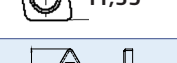

Part	Code	M	L	d	A	Key
	TC057	M1,6	3,4	2,6	60°	T6
	TC057-1	M1,8	4,1	2,5	60°	T6
	TC058	M2	4,2	2,8	60°	T6
	TC058-1	M2	5	2,8	60°	T6
	TC058-2	M2,2	6	3	60°	T7
	TC059	M2,2	5	3	60°	T7
	TC059-1	M2,5	4,7	3,5	60°	T8
	TC060	M2,5	5,5	3,5	60°	T8
	TC061	M2,5	6,5	3,5	50°	T8
	TC063	M2,5	7	3,5	60°	T8
	TC092	M2,5	5,5	3,8	60°	T8
	TC093	M2,5	7	3,8	60°	T8
	TC064	M3	6,2	3,8	60°	T8
	TC065	M3	7	4,2	60°	T8
	TC065-1	M3	7	4	60°	T8
	TC066	M3,5	10	5,3	55°	T15
	TC067	M3,5	8,5	5,3	60°	T15
	TC068	M3,5	11	5,3	60°	T15
	TC069	M3,5	8,5	4,8	60°	T10
	TC071	M3,5	7	5,3	60°	T15
	TC072	M4	10	5,5	60°	T15
	TC073	M4	8,5	5,5	60°	T15
	TC074	M4	10	5,5	60°	T15
	TC075	M4	11	7	60°	T15
	TC076	M4	12,5	5,5	60°	T15
	TC077	M4	15	6,8	60°	T15
	TC078	M4	11	6,7	60°	T15
	TC079	M4	11	5,2	45°	T15
	TC080	M4,5	11	6,2	60°	T15
	TC083	M5	12	7	60°	T20
	TC085	M5	12	6,6	75°	T20
	TC086	M5	18	7,5	60°	T20
		TC048	M5	9	6,3	
TC049		M5	7,7			3,5 Allen
TC049-1		M6	10			4 Allen

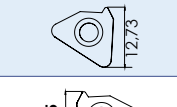
	Code	M	L	d	Key
 	TC050	M6	14	11,2	3 Allen
	TC052	M6	17	14	4 Allen
	TC054	M8	24	17,1	5 Allen
	TC056	M8 (sol-left)	24	17,1	5 Allen
 	TC300	M8	21		4 Allen
 	TC044	M6	27	11	3 Allen
	TC046	M5	26	10	3 Allen
	TC047	M8	29	13,6	5 Allen
 	TC130	M5	12	8,5	4 Allen
	TC131	M5	16	8,5	4 Allen
	TC132	M5	20	8,5	4 Allen
	TC134	M6	20	9,8	5 Allen
 	TH512	M5	12		2 Allen
	TH613	M6	13,4		2,5 Allen
	TH617	M6	17		2 Allen
	TH818	M8	18		3 Allen
	TH821	M8	21		3 Allen
	TH822	M8	22		2,5 Allen
	TH825	M8	25		3 Allen
 	TC036	M3	10	5,6	T10
 	TC038	M4	10	7,30	T15
 	TC039	M6	12	10,6	4 Allen
 	TC040	M3,5	10	8	T15
 	TC062	M3	6,7	5,5	T15
	TC053	M4	9	6,5	T20
	TC053-1	M4	9	6,5	T15
 	TC095	M5	12	9,5	3 Allen
 	TC170	M3	7	4,2	T8
	TC172	M4	9	5,8	T15
	TC174	M5	10	7	T20
	TC176	M5	12	7,3	T20
	TC178	M5	16	7,8	3 Allen
	TC181	M6	22	9,5	3 Allen
	TC184	M8	25	13	4 Allen

Code	Type	Part	Dimensions (mm)
			M
BK017	DNMG 11		
BK017-1	TNMG 16		
BK018	CNMG 16		
BK019	WNMG 06		
BK020	DNMG 15 CNMG 12 SNMG 12		
BK021	VNMG 16		
BK022	TNMG 16		
BK023	TNMG 22		
BK024	DNMG 11 (Small)		
BK025	CNMG 19		
BK027	SNMG 25		
BK026	WNMG 08		
BK028	KNUX Sağ/ Right		
BK030	KNUX/Left		
BK035	RDMT 16		
BK036	TPKN16		
BK300	OFCR 07		

Code	Type	Part	Dimensions (mm)
			M
BSP010	Washer		
BSP030	Washer (Normal)		
BSP031	Washer		
BSP032	Washer		
BY040	M6		
BY041	M5		
BY042	M6		
BY043	M5		
BY044			
BSP020	TNMG 16 WNMG 06		
BSP021	TNMG 22 DNMG 11 WNMG 08		
TL3	L12,2-D3,5		
TL3B	L10-D3		
TL4	L13-D4,5		
TL4A	L10,5-D4,7		
TL4B	L15,6-D5		
TS-3	D6,65-L5,5		
TS-4	D7,71-L7		

Code	Type	Part	Dimensions (mm)	
			M	
TA014	DNMG 15 Shim			
TA014-1	DNMG 15 Shim			
TA013	DNMG 11 Shim			
TA023	CNMG 09 Shim			
TA016	CNMG 12 Shim			
TA016-1	CNMG 12 Shim			
TA022	CNMG 16 Shim			
TA017	CNMG 19 Shim			
TA021	WNMG 06 Shim			
TA020-1	WNMG 08 Shim			
TA020	WNMG 08 Shim			
TA019	TNMG 16 Shim			
TA045	TNMG 22 Shim			
TA052	SEET 12 Shim			

Code	Type	Part	Dimensions (mm)	
			M	
TA050	SNMG 12 Shim			
TA051	SNMG 19 Shim			
TA053	SNMG 25 Shim			
TA046	KNUX RIGHT Shim			
TA048	KNUX LEFT Shim			
TA030	DCMT 11 Shim			
TA034	VBMT 16 Shim			
TA032	VCMT 16 Shim			
TA033	VNMG 16 Shim			
TA010	TPKN 16 Shim			
TA012	TPKN 22 Shim			
TA015	CCMT 09 Shim			
TA015-1	CCMT 12 Shim			
TA040	ER 16 Shim			
TA061	16 ER Shim			
TA060	16 IR Shim			
TA062	22 ER Shim			
TA063	22 IR Shim			
TA064	27 ER Shim			
TA065	27 IR Shim			

**S 3 2 T D D U N R 1 5**

1	2	3	4	5	6	7	8	9				
Type of Shank <i>Schaftansführung</i>	Shank <i>Schaft</i>	Tool Length <i>Werkzeuglänge</i>	Clamping System <i>Klemmsystem</i>	From <i>WSP-Form</i>	Tool Type Shank <i>Werkzeugtyp</i>	Insert Clear- ance <i>WSP-Freiwinkel</i>	Holder Ex- ecution <i>Bearbestungs- richtung</i>	Cutting Edge <i>WSP- Grösse</i>				
A: Çelik Gövdeli içten Sogutmalı Coolan Through Steel Shank <i>Mit Kühlbohrung</i>			<p>D <i>ÇEKTIRMELİ</i></p> <p>M <i>BASKI PABUÇLU</i></p> <p>P <i>LEVYELİ</i></p> <p>S <i>VIDALI</i></p>	<p>A </p> <p>B </p> <p>C </p> <p>D </p> <p>E </p> <p>H </p> <p>K </p> <p>L </p> <p>M </p> <p>O </p> <p>P </p> <p>R </p> <p>S </p> <p>T </p> <p>V </p> <p>W </p>	<p>F </p> <p>L </p> <p>Q </p> <p>S </p> <p>U </p> <p>W </p> <p>Z </p> <p>X </p>	<p>3°</p> <p>5°</p> <p>7°</p> <p>15°</p> <p>20°</p> <p>25°</p> <p>30°</p> <p>11°</p>	R	<p>A </p> <p>B </p> <p>C </p> <p>D </p> <p>E </p> <p>K </p> <p>L </p> <p>M </p> <p>O </p> <p>P </p> <p>R </p> <p>S </p> <p>T </p> <p>V </p> <p>W </p>				
	06 = 6	D = 60										
	08 = 8	E = 70										
	10 = 10	F = 80										
	12 = 12	G = 90										
	14 = 14	H = 100										
	16 = 16	J = 110										
	20 = 20	K = 125										
	22 = 22	L = 140										
	25 = 25	M = 150										
32 = 32	N = 160											
40 = 40	P = 170											
50 = 50	Q = 180											
C: Toz Metal Gövdeli Hardmetal Shank <i>Hartmetall Stahlkopf</i>		R = 200	<p>X = ÖZEL Special Sonderform</p>	<p>Özel Special O</p>	<p>N</p>	<p>L</p>	<p>Özel Special O</p>					
		S = 250										
		T = 300										
		U = 350										
		V = 400										
		W = 450										
		Y = 500										
		X = ÖZEL Special Sonderform										
	E: Toz Metal Gövdeli içten Sogutmalı Hardmetal Shank With Coolant Hole <i>Hartmetall Schaftmit Stahlkopf und Kühlbohrung</i>								<p>Özel Special O</p>	<p>Özel Special O</p>	<p>Özel Special O</p>	<p>Özel Special O</p>
S: Çelik Gövdeli Steel Shank <i>Stahl Schaft</i>			<p>Özel Special O</p>	<p>Özel Special O</p>	<p>Özel Special O</p>	<p>Özel Special O</p>						

**D**      **D**      **J**      **N**      **R**      **20**      **20**      **K**      **15**

1	2	3	4	5	6	7	8	9
Clamping System Klemmsystem	Cutting Style Plattenform	Type Werkzeugtyp	Clearance angle WSP-Freiwinkel	Holder Execution Bearbeitungsrichtung	Height of Shank Schaftquerschnitts	Width of Shank Schaftbreite	Leng of Holder Werkzeuglänge	Leng of Holder Werkzeuglänge
<p><b>D</b></p> <p><b>M</b></p> <p><b>P</b></p> <p><b>S</b></p>	<p>A </p> <p>B </p> <p>C </p> <p>D </p> <p>E </p> <p>H </p> <p>K </p> <p>L </p> <p>M </p> <p>O </p> <p>P </p> <p>R </p> <p>S </p> <p>T </p> <p>V </p> <p>W </p>	<p>A </p> <p>B </p> <p>C </p> <p>D </p> <p>E </p> <p>F </p> <p>G </p> <p>J </p> <p>K </p> <p>L </p> <p>N </p> <p>P </p> <p>Q </p> <p>R </p> <p>S </p> <p>V </p>	<p>A </p> <p>B </p> <p>C </p> <p>D </p> <p>E </p> <p>F </p> <p>G </p> <p>P </p> <p>N </p> <p>O </p>	<p><b>L</b></p> <p><b>R</b></p> <p><b>N</b></p>	<p>(mm)</p> <p>06 = 6</p> <p>08 = 8</p> <p>10 = 10</p> <p>12 = 12</p> <p>14 = 14</p> <p>16 = 16</p> <p>20 = 20</p> <p>22 = 22</p> <p>25 = 25</p> <p>32 = 32</p> <p>40 = 40</p> <p>50 = 50</p>	<p>(mm)</p> <p>06 = 6</p> <p>08 = 8</p> <p>10 = 10</p> <p>12 = 12</p> <p>14 = 14</p> <p>16 = 16</p> <p>20 = 20</p> <p>22 = 22</p> <p>25 = 25</p> <p>32 = 32</p> <p>40 = 40</p> <p>50 = 50</p>	<p>(mm)</p> <p>D = 60</p> <p>E = 70</p> <p>F = 80</p> <p>G = 90</p> <p>H = 100</p> <p>J = 110</p> <p>K = 125</p> <p>L = 140</p> <p>M = 150</p> <p>N = 160</p> <p>P = 170</p> <p>Q = 180</p> <p>R = 200</p> <p>S = 250</p> <p>T = 300</p> <p>U = 350</p> <p>V = 400</p> <p>W = 450</p> <p>Y = 500</p> <p>X = ÖZEL Special Sonderform</p>	<p>A </p> <p>B </p> <p>C </p> <p>D </p> <p>E </p> <p>K </p> <p>L </p> <p>M </p> <p>O </p> <p>P </p> <p>R </p> <p>S </p> <p>T </p> <p>V </p> <p>W </p>

